

XS1B Aircraft Water Filter

Part No. EV941000

FAA-PMA APPROVED



XS1B Assembly
P/N EV941000 (1 pack)



*Premium Quality Water Filtration
Created for Use in Aircraft*

BENEFITS

- Improves aircraft water by reducing chlorine taste and odor and other off tastes and odors
- Filters out dirt and other suspended matter
- Vessel made of durable “300 Series” stainless steel
- Designed for use with all Everpure D-Clor™ Cartridges
- FAA-PMA Approved

INSTALLATION TIPS

- To service, shut off influent water supply, open service tap, remove the V-Band Clamp, and unscrew cartridge.
- After replacing cartridge, air should be released from the top vent.
- **Flush the cartridges by running water through filter at full flow at the service tap for three minutes, or until water runs clear.**

OPERATION TIPS

- Change cartridges as indicated on the cartridge data sheet.
- **Always flush new filter cartridges at the time of installation.**

INLET AND OUTLET CONNECTIONS

- **Bottom IN / Bottom OUT** Top Vent
- Inlet and Outlet: 9/16-inch — 18NF (3/8-inch tube union)

REPLACEMENT CARTRIDGES

- All D-Clor™ cartridges reduce chlorine taste and odor, and other taste and odor while filtering out dirt and suspended matter. See chart for different pressure drop characteristics.
- In addition to reducing taste and odors, the 150GP cartridge inhibits limescale build-up. Limescale prevention is particularly important in applications involving hot water heaters and coffee makers.



150B D-Clor™ Replacement Cartridge
P/N EV949812
(12 Pack)



150G D-Clor™ Replacement Cartridge
P/N EV949000
(12 Pack)



150GP D-Clor™ Replacement Cartridge
P/N EV949212
(12 Pack)



150GY D-Clor™ Replacement Cartridge
P/N EV949012
(12 Pack)

PRESSURE DROP CHARACTERISTICS

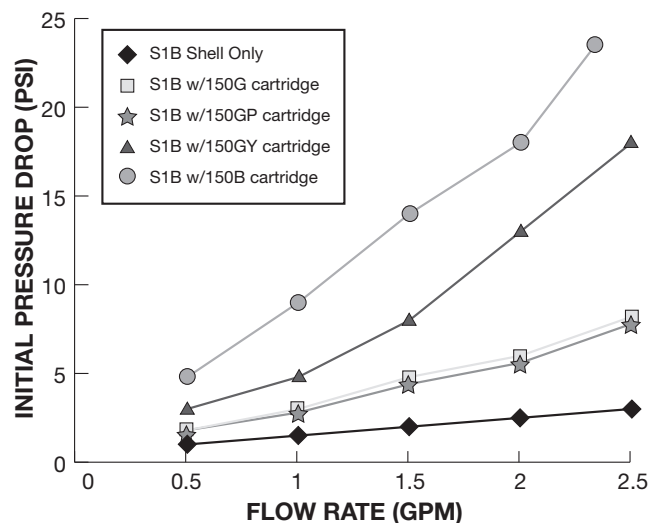

SPECIFICATIONS

Dimensions

7³/₄" H x 4¹⁵/₁₆" D (19.7 cm H x 12.5 cm D)

Including V-Band: 5³/₄" (14.6 cm) D

Net Weight

2¹/₂ lbs (1.2 kg) including cartridge

Inlet and Outlet Connections: Bottom IN / Bottom OUT

Top Vent

Inlet and Outlet: 9/16-inch 18NF (3/8-inch tube union)

Service Flow Rate

Minimum 0.5 gpm (1.9 L/min)

Maximum 1.67 gpm (6.32 L/min)

Working Pressure

Up to 125 psi (8.62 bar), non-shock

Maximum Temperature

160°F (71.1°C)

No electrical connection required.

LIMITED WARRANTY OF PHYSICAL QUALITY

If, within eighteen months after manufacture or twelve months after purchase (whichever occurs first), any part of Pentair Filtration, Inc.'s manufacture which is returned to its factory, shipping charges prepaid, is found to be defective in material or workmanship in the judgement of Pentair Filtration, Inc.'s engineers, Pentair Filtration, Inc. will repair or replace such part at no charge, f.o.b., Sheboygan factory. Pentair Filtration, Inc., however, shall not be liable for damages or delays caused by any defective material or workmanship, or by failure of any parts due to normal wear and tear. Pentair Filtration, Inc. will not be responsible for products which malfunction due to user neglect or unauthorized modification.

NOTE: Some states do not allow limitations on how long an implied warranty lasts, so the above limitation may not apply to you. Similarly, some states do not allow the exclusion or limitation of consequential or incidental damages, so the above limitation or exclusion may not apply to you. This warranty gives you specific legal rights and you may also have other rights which may vary from state to state.

PARTS LIST & DIMENSIONS

Item Number	Description	Part Number
1	Top, Polished Stainless Steel	EV011400
2	Gasket (ATA Packaged)	EV034401
3	Quick-Opening V-Band	EV013400
4	D-Clor™ Cartridge See front page for P/N	150G, 150GY 150B, 150GP
5	Shell, Polished Stainless Steel	EV012300

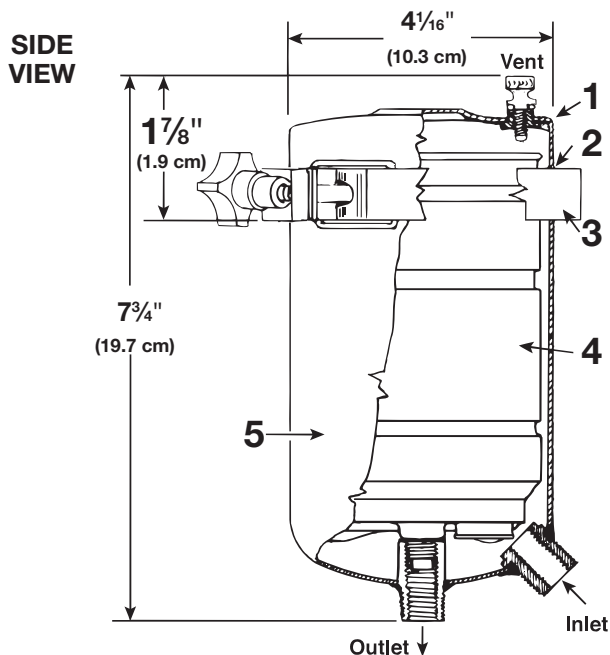
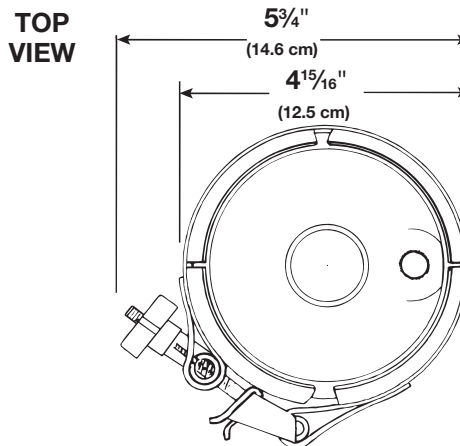

EVERPURE
WATER YOU CAN TRUST®

Pentair Filtration, Inc.
502 Indiana Avenue - P.O. Box 1047
Sheboygan, Wisconsin 53082-1047
Phone 866.873.7506 Fax 888.203.7361
International Phone 920.457.9435 International Fax 920.457.2417
www.everpure.com