



EV9980-10
WS-Series

Water Conditioning for Commercial and Light Industrial Applications Available in Single Tank System with 1" Porting



WS-30: EV9980-10

BENEFITS

- Hardness removal of 30,000 to 45,000 grains at flow rates up to 12 gallons per minute continuous
- Meter initiated regeneration minimizes salt, water and electrical costs
- Advanced user-friendly controls incorporates time-tested hydraulically balanced piston, seal and spacer design to pilot service flow and regeneration
- Large capacity brine tank maximizes time between refills
- Fiberglass reinforced resin vessels with NSF approved polyethylene liners eliminate worries about corrosion
- Single tank design for simplicity, economy and space savings
- 5-cycle control delivers controlled upflow backwash, downflow brining and slow rinse, rapid rinse, timed brine refill and downflow service

INSTALLATION TIPS

- Locate equipment on a smooth, level surface
- Maintain an air-gap at the end of the drain line
- Secure drain line directly over floor drain or stand pipe
- When connecting a water heater, install a check valve on the soft water piping to prevent hot water back-up
- When sweating/installing copper piping, protect the control valve from excessive heat
- Check local codes for additional equipment that may be required, such as backflow prevention devices (i.e., RPZ)

OPERATION TIPS

- Check for softened water each time salt is added, by using soap of hardness test kit
- Use a good quality grade of salt - Solar or pellet are preferred
- Check the salt level on a regular basis
- Maintain a minimum Salt depth of 6" to ensure a proper regeneration
- On iron bearing waters, use a salt that contains an iron "fighting" additive, or use a resin cleaner on a regular basis
- Check the water level in the brine tank. If abnormally high - refer to IO guide for troubleshooting information

APPLICATION/SIZING

- Reverse Osmosis Pre-treatment
- Espresso Machines
- Warewashing
- Laundry- Linen & Uniform
- Boiler Scale Control
- Water Heater Scale Protection/Reduction
- General Housekeeping

SPECIFICATIONS

WS-Series

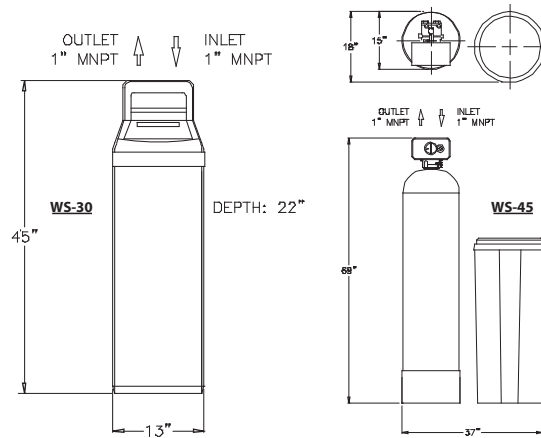

WARRANTY

Everpure water treatment systems (excluding replaceable elements) are covered by a limited warranty against defects in material and workmanship for a period of five years after date of purchase. Everpure replaceable elements (filter cartridges and water treatment cartridges) are covered by a limited warranty against defects in material and workmanship for a period of one year after date of purchase. See printed warranty for details. Everpure will provide a copy of the warranty upon request.

EVERPURE®

Worldwide Headquarters:
 EVERPURE, LLC
 1040 Muirfield Drive
 Hanover Park, Illinois 60133
 Toll Free (800) 323-7873
 Tel (630) 307-3000
 Fax (630) 307-3030
<http://www.everpure.com>

In Europe:
 Pentair Water Belgium B.V./B.A.
 Industriepark Wolfstee
 Toekomstlaan 30
 B- 2200 Herentals
 BELGIUM
 TEL: +32.(0).14.283.500
 FAX: +32.(0).14.283.505

In Japan:
 Hashimoto MN Bldg. 7F
 3-25-1 Hashimoto Sagamihara-Shi
 Kanagawa 229-1103
 JAPAN
 TEL: 81.(0)42.775.3011
 FAX: 81.(0)42.775.3015