



EV9797-91

MRS-20

**Complete Mineral Reduction Water Processing System**



MRS-20 System: EV9797-91

4CB5 cartridge: EV9617-11

MR-20 Cartridge: EV9273-69

**BENEFITS**

Improves equipment life and performance by removing at least 90%+ of all dissolved solids that cause scale build-up

Protects against taste and odor causing contaminants while removing dirt, particulates and dissolved minerals

Less frequent deliming of equipment means reduced maintenance and service costs

Sanitary cartridge replacement is simple, quick and clean. Internal filter parts are never exposed to handling or contamination

Two-part design makes installation flexible, and small footprint easily fits in any kitchen

Easy to operate system has no moving parts and requires no electrical power

System includes mineral reduction processor, carbon filter cartridge, reverse osmosis cartridge, and storage tank

No monitoring of grains per gallons is necessary. System removes scale reducing minerals regardless of the GPG

**INSTALLATION TIPS**

Choose a mounting location suitable to support the full weight of the system when operating

Mount system convenient to the post water softener supply line and for routing the outlet and drain lines

The tank assembly may be mounted above, below or alongside (preferred) of the water processor assembly

Install vertically with cartridges hanging down. Allow 2-1/2" clearance below the cartridge for easy cartridge replacement

The water inlet must supply a minimum of 0.5 gpm at 50-85 psi on a consistent basis

Deliming of equipment prior to application is recommended

**OPERATION TIPS**

Replace the 4CB5-MR carbon filter every 12 months. Change the 4MR-1 mineral reduction cartridge every two years, or as needed

Cartridge replacement schedules assume the system is installed on softened water

Outlet Water Production: 25 gal. per day (54.5L) @ 50 psig (340 kPa), 77 F (25 C) per NSF Standard 58 testing. Water production depends on supply water pressure and temperature

Wastewater Production: 74 gal. per day (289L) @ 50 psig (340 kPa), 77 F (25 C). Wastewater drain line capacity: 3 gpm (21 Lpm) to open atmosphere

Storage Tank Capacity: 3 gallon tank; effective/usable capacity: 2.5 gal. (9.5L)

**APPLICATION/SIZING**

Mineral Reduction System for foodservice applications

Ideal for: Flash steamers, conventional steamers, cheese melters, combi-ovens and coffee/espresso machines

Uniquely designed for low volume applications (approximately 25 gpd nominal consumption)

# MRS-20

## SPECIFICATIONS

### Overall Dimensions:

Processor - 25"H x 22.5"W x 5"D

Tank - 27"H x 22.5"W x 11.25"D

### Inlet and Outlet connection:

3/8" OD John Guest tubing fitting (provided)

3/8" ID beverage hose

### Wastewater line and Sample port connection:

1/4" OD John Guest tubing fitting (provided)

### Steamer manifold connection:

1/4" quick connect on tubing coil (provided)

### Steamer feed hose connection:

3/8" barb on tubing coil (provided)

### Pressure Requirements:

10 psi - 125 psi (0.7 – 8.6 bar), non-shock

### Water Supply:

0.5 gpm (1.9L) @ 50-85 psi (280-595 Kpa)

### Inlet Temperature:

40°F - 100°F (4-38°C)

### Inlet TDS:

1,500 ppm max recommended

Operating Weight: 50 lbs.

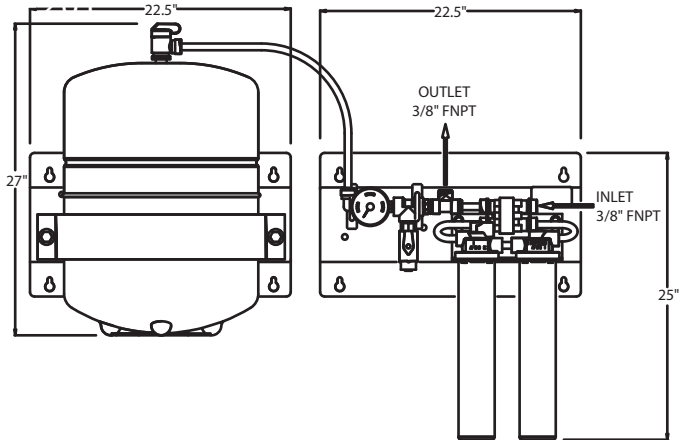

## WARRANTY

Everpure water treatment systems (excluding replaceable elements) are covered by a limited warranty against defects in material and workmanship for a period of five years after date of purchase. Everpure replaceable elements (filter cartridges and water treatment cartridges) are covered by a limited warranty against defects in material and workmanship for a period of one year after date of purchase. See printed warranty for details. Everpure will provide a copy of the warranty upon request.

The contaminants or other substances removed or reduced by this drinking water system are not necessarily in your water. Do not use with water that is microbiologically unsafe or of unknown quality without adequate disinfection before or after the system. Systems certified for cyst reduction may be used with disinfected water that may contain filterable cysts.

### EVERPURE®

EVERPURE, LLC  
1040 Muirfield Drive  
Hanover Park, Illinois 60133  
Toll Free (800) 323-7873  
Tel (630) 307-3000  
Fax (630) 307-3030  
<http://www.everpure.com>

*In Europe:*  
N.V. EVERPURE (EUROPE) S.A.  
INDUSTRIEPARK WOLFSTEE  
TOEKOMSTLAAN 30  
B-2200 HERENTALS  
BELGIUM  
TEL 32 -14-283500  
FAX 32-14-283505

*In Japan:*  
EVERPURE JAPAN LLC  
HASHIMOTO MN BLDG. 7F  
3-25-1 HASHIMOTO SAGAMIHARA-SHI  
KANAGAWA 229-1103  
JAPAN  
TEL 81-(0)42-775-3011  
FAX 81-(0)42-775-3015

Everpure, LLC  
1040 Muirfield Drive  
Hanover Park, IL 60133  
Ph: 630-307-3000 Fax: 630-307-3030