



WELLS BLOOMFIELD, LLC
2 ERIK CIRCLE, P. O. Box 280 Verdi, NV 89439
telephone: 775-689-5703
fax: 775-689-5976
www.wellsbloomfield.com

595



*Model HD8799
Heated Dispenser*

**OWNERS MANUAL
for
HEATED DISPENSER**

**MODEL:
HD8799 2½-Gallon
HD8802 5-Gallon**

Includes:

**Installation
Operation
Use & Care
Servicing Instructions**

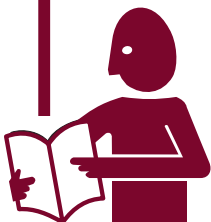

IMPORTANT: DO NOT DISCARD THIS MANUAL

This manual is considered to be part of the appliance and is to be given to the OWNER or MANAGER of the restaurant, or to the person responsible for TRAINING OPERATORS of this appliance. Additional manuals are available from your WELLS DEALER.

THIS MANUAL MUST BE READ AND UNDERSTOOD BY ALL PERSONS USING OR INSTALLING THIS APPLIANCE. Contact your WELLS DEALER if you have any questions concerning installation, operation or maintenance of this equipment.

PRINTED IN UNITED STATES OF AMERICA

LIMITED WARRANTY STATEMENT

Unless otherwise specified, all commercial cooking equipment manufactured by WELLS BLOOMFIELD, LLC is warranted against defects in materials and workmanship for a period of one year from the date of original installation or 18 months from the date of shipment from our factory, whichever comes first, and is for the benefit of the original purchaser only.

THIS WARRANTY IS THE COMPLETE AND ONLY WARRANTY, EXPRESSED OR IMPLIED IN LAW OR IN FACT, INCLUDING BUT NOT LIMITED TO, WARRANTIES OF MERCHANTABILITY OR FITNESS FOR ANY PARTICULAR PURPOSE, AND/OR FOR DIRECT, INDIRECT OR CONSEQUENTIAL DAMAGES IN CONNECTION WITH WELLS BLOOMFIELD PRODUCTS.

This warranty is void if it is determined that, upon inspection by an authorized service agency, the equipment has been modified, misused, misapplied, improperly installed, or damaged in transit or by fire, flood or act of God. It also does not apply if the serial nameplate has been removed, or if service is performed by unauthorized personnel. The prices charged by Wells Bloomfield for its products are

based upon the limitations in this warranty. Seller's obligation under this warranty is limited to the repair of defects without charge by a Wells Bloomfield factory authorized service agency or one of its sub-service agencies. This service will be provided on customer's premises for non-portable models. Portable models (a device with a cord and plug) must be taken or shipped to the closest authorized service agency, transportation charges prepaid, for service. In addition to restrictions contained in this warranty, specific limitations are shown in the Service Policy and Procedure Guide. Wells Bloomfield authorized service agencies are located in principal cities. This warranty is valid in the United States and Canada and void elsewhere. Please consult your classified telephone directory, your foodservice equipment dealer or contact:

**Service Department, Wells Bloomfield, LLC
P.O. Box 280, Verdi, Nevada 89439
phone (775) 689-5707 or fax (775) 689-5976**

for information and other details concerning warranty.

SERVICE POLICY AND PROCEDURE GUIDE and ADDITIONAL WARRANTY EXCLUSIONS

1. Resetting of safety thermostats, circuit breakers, over load protectors, and/or fuse replacements are **not** covered by this warranty unless warranted conditions are the cause.
2. All problems due to operation at **voltages or phase other than specified on equipment nameplates** are **not** covered by this warranty. Conversion to correct voltage and/or phase must be the customer's responsibility.
3. All problems due to **electrical connections not made in accordance with electrical code requirements and wiring diagrams** supplied with the equipment are **not** covered by this warranty.
4. Replacement of items **subject to normal wear**, to include such items as knobs, light bulbs; and, normal maintenance functions including adjustments of thermostats, adjustment of micro switches and replacement of fuses and indicating lights are **not** covered by warranty.
5. Damage to electrical cords and/or plug due to exposure to excessive heat are **not** covered by this warranty.
6. Full use, care, and maintenance instructions supplied with each machine. Noted maintenance and preventative maintenance items, such as servicing and cleaning schedules, are customer responsibility. Those miscellaneous adjustments noted are customer responsibility. Proper attention to preventative maintenance and scheduled maintenance procedures will prolong the life of the appliance.
7. Travel mileage is limited to **sixty (60) miles** from an Authorized Service Agency or one of its sub-service agencies.
8. All labor shall be performed during regular working hours. Overtime premium will be charged to the buyer.
9. All genuine Wells replacement parts are warranted for ninety (90) days from date of purchase on non-warranty equipment. This parts warranty is limited only to replacement of the defective part(s). **Any use of non-genuine Wells parts completely voids any warranty.**
10. Installation, labor, and job check-outs are **not** considered warranty and are thus **not** covered by this warranty.
11. Charges incurred by delays, waiting time or operating restrictions that hinder the service technician's ability to perform service are **not** covered by warranty. This includes institutional and correctional facilities.

SHIPPING DAMAGE CLAIM PROCEDURE

NOTE: For your protection, please note that equipment in this shipment was carefully inspected and packaged by skilled personnel before leaving the factory. Upon acceptance of this shipment, the transportation company assumes full responsibility for its safe delivery.

IF SHIPMENT ARRIVES DAMAGED:

1. **VISIBLE LOSS OR DAMAGE:** Be certain that any visible loss or damage is noted on the freight bill or express receipt, and that the note of loss or damage is signed by the delivery person.
2. **FILE CLAIM FOR DAMAGE IMMEDIATELY:**
Regardless of the extent of the damage.

3. **CONCEALED LOSS OR DAMAGE:** if damage is unnoticed until the merchandise is unpacked, notify the transportation company or carrier immediately, and file "CONCEALED DAMAGE" claim with them. This should be done within fifteen (15) days from the date the delivery was made to you. Be sure to retain the container for inspection.

Wells Bloomfield cannot assume liability for damage or loss incurred in transit. We will, however, at your request, supply you with the necessary documents to support your claim.

TABLE OF CONTENTS

WARRANTY	xi	Thank You for purchasing this Wells Bloomfield appliance.
SPECIFICATIONS	1	
FEATURES & OPERATING CONTROLS	2	
PRECAUTIONS & GENERAL INFORMATION	3	Proper installation, professional operation and consistent maintenance of this appliance will ensure that it gives you the very best performance and a long, economical service life.
AGENCY LISTING INFORMATION	3	
INSTALLATION	4	
OPERATION	5	
CLEANING INSTRUCTIONS	6	
TROUBLESHOOTING SUGGESTIONS	7	
SERVICING INSTRUCTIONS	7	This manual contains the information needed to properly install this appliance, and to use and care for the appliance in a manner that will ensure its optimum performance.
EXPLODED VIEW & PARTS LIST	8	
FAUCET REPAIR	10	
WIRING DIAGRAM	10	
PARTS & SERVICE	11	

SPECIFICATIONS

MODEL	VOLTS 50/60 Hz	WATTS	AMPS 1ø	POWER SUPPLY CORD
HD8799	120	200	1.7	6' NEMA 5-15P
HD8802				

HD8799 2½-Gallon Dispenser

HEIGHT	OVERALL WIDTH	OVERALL DEPTH	CAPACITY	FIXED TEMPERATURE
20 - 11/16" (510 mm)	12 - 7/8" (328 mm)	14 - 1/4" (361 mm)	2 - 1/2 gallon (10 liter)	140°F (60°C)

HD8802 5-Gallon Dispenser

HEIGHT	OVERALL WIDTH	OVERALL DEPTH	CAPACITY	ADJUSTABLE TO TEMPERATURE
24-1/4" (621mm)	14-1/4" (361mm)	15" (381mm)	5 gallon (20 liter)	170°F (77°C)

APPLICABILITY

This manual applies to the following Wells products:

- HD8799 2½-Gallon Heated Dispenser
- HD8802 5-Gallon Heated Dispenser

FEATURES & OPERATING CONTROLS

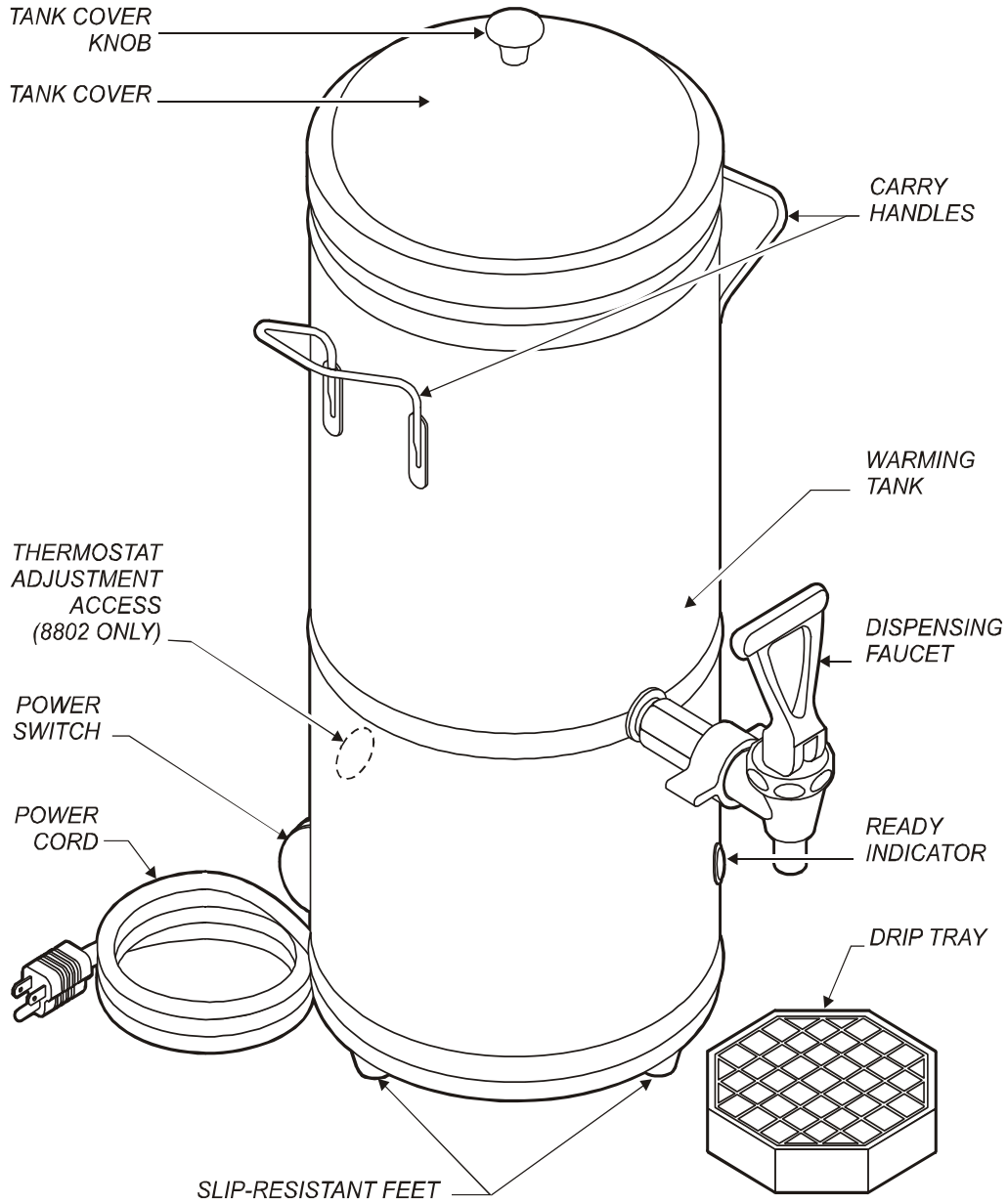

Fig. 1 Features & Operating Controls

595 p/n 75982 OPM Heated Dispenser

PRECAUTIONS AND GENERAL INFORMATION



WARNING: Electric Shock Hazard

All servicing requiring access to non-insulated components must be performed by qualified service personnel. Do not open any access panels which require the use of tools. Failure to heed this warning can result in electrical shock.



WARNING Electric Shock Hazard

Warmer must be properly grounded to prevent possible shock hazard. Electrical shock will cause death or serious injury.

This appliance is intended for commercial use only.

This appliance is intended for use to warm syrup for human consumption. No other use is recommended or authorized by the manufacturer or its agents.

This appliance is intended for use in commercial establishments, where all operators are familiar with the appliance use, limitations and associated hazards. Operating instructions and warnings must be read and understood by all operators and users.

Except as noted, this piece of equipment is made in the USA and has American sizes on hardware. All metric conversions are approximate and can vary in size.

The following trouble shooting, component views and parts lists are included for general reference, and are intended for use by qualified service personnel.

This manual should be considered a permanent part of this appliance. The manual must remain with the appliance if it is sold or moved to another location.



CAUTION: Equipment Electrical Damage

DO NOT plug in or energize this appliance until all *Installation Instructions* are read and followed. Damage to the warmer may occur if these instructions are not followed.



CAUTION: Burn Hazard

Exposed surfaces of the appliance may be HOT to the touch and can cause burns.

AGENCY LISTING INFORMATION

This dispenser is  and  listed under UL file E9253

This dispenser meets  Standard 4 only when installed, operated and maintained in accordance with the enclosed instructions.



INSTALLATION

READ THIS CAREFULLY BEFORE STARTING THE INSTALLATION



CAUTION: Equipment Electrical Damage

DO NOT plug in or energize this appliance until all Installation Instructions are read and followed. Damage to the Brewer will occur if these instructions are not followed.



CAUTION: Unstable Equipment Hazard

It is very important for safety and for proper operation that the warmer is level and stable when standing in its final operating position. Provided non-skid feet must be installed at each corner of the unit. Do not install this appliance if the feet are missing or damaged.



WARNING ELECTRIC SHOCK HAZARD:

Warmer must be properly grounded to prevent possible shock hazard. Electrical shock will cause death or serious injury.

IMPORTANT:

Supply power must match nameplate for voltage and phase. Connecting to the wrong voltage will damage the warmer or result in decreased performance. Such damage is not covered by warranty.

REFER TO EXPLODED VIEWS PAGE 9 FOR COMPONENT NAMES/NUMBERS

Unpack the unit. Inspect all components for completeness and condition. Ensure that all packing materials have been removed from the unit.

LEVELING THE UNIT

Verify that a slip-resistant foot is installed at each corner of the dispenser.

Set the warmer in its operating location. Be sure all four feet touch the counter to prevent tipping.

ELECTRICIAN'S INSTALLATION INSTRUCTIONS

REFER TO ELECTRICAL SPECIFICATIONS - Page 1
Check the nameplate to determine correct electrical service required for the warmer.

Models HD8799 and HD8802 dispensers are equipped with a cord and plug. They requires a 115 - 125 volt circuit (50/60 Hz, 2 wire plus ground, with NEMA 5-15R receptacle).

IMPORTANT: The ground prong of the plug is part of a system designed to protect you from electrical shock in the event of internal damage. Never cut off the ground prong nor twist a blade to fit an existing receptacle. Contact a licensed electrician to install the proper circuit and receptacle.

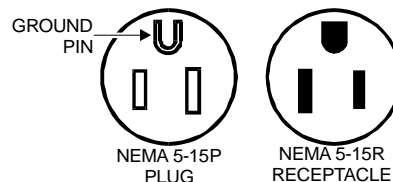

PREPARATION

Prior to first use, thoroughly clean warmer (see page 6).

Be sure faucet handle is "up" and that drip tray is in place under faucet.

USE

Pour product into warming tank. Using pre-heated product will reduce heat-up time.

Model HD8799 utilizes a fixed thermostat to hold product at 140°F (60°C).

Model HD8802 thermostat may be adjusted to hold product at 170°F (77°C) maximum.

Reinstall tank cover.

Plug dispenser into an appropriate electrical receptacle. Turn power switch to *ON*.

When the READY light glows, product is ready to serve:

Place an appropriate container under the faucet.

Pull the faucet handle to dispense product.

Release the handle to stop the flow of product.

NIGHTLY CLOSE

Turn the power switch to *OFF* and unplug the dispenser.

If required, empty the dispenser and clean.

TEMPERATURE ADJUSTMENT (Model HD8802 only)

Remove button plug from rear of dispenser to access thermostat. Turn shaft of thermostat to adjust setpoint temperature. Turn the shaft clockwise to increase temperature. Moving the shaft 1/8 turn will change the temperature approximately 10°F.

**CAUTION:
Burn Hazard**

Exposed surfaces of the appliance may be HOT to the touch and can cause burns.

NOTE: Product may continue to flow for several seconds after the faucet is released. Do not remove the container until all flow has stopped.

IMPORTANT: Your local Health Department can advise whether or not a particular product may be left in the dispenser overnight.

IMPORTANT: Temperature adjustment to be performed by authorized personnel only.

CLEANING INSTRUCTIONS



CAUTION:
Electric Shock
Hazard

Do not submerge or immerse dispenser in water.



CAUTION:
Burn Hazard

This procedure requires the use of very hot water. Wear protective gloves while cleaning the warmer. Very hot water can cause burns.

IMPORTANT:

DO NOT use steel wool, sharp objects, or caustic, abrasive or chlorinated cleansers to clean the dispenser.

PROCEDURE: Clean Heated Dispenser

PRECAUTIONS: Disconnect dispenser from electric power. Drain product and allow dispenser to cool.

FREQUENCY: Daily or after draining product from dispenser

TOOLS: Mild Detergent, Clean Soft Cloth or Sponge
Long Handle Bristle Brush

1. Disconnect warmer from electric power. Drain product and allow warmer to cool before cleaning.
2. Fill warmer with very hot water.
3. Place an appropriate container under the faucet. Use a long handle bristle brush to stir the water while draining the hot water from the warmer.
4. Wipe the warmer inside and out with a soft cloth or sponge dampened with water and mild detergent.
5. Rinse the warmer inside and out with a soft cloth or sponge dampened with clean water.
6. Wipe the tank cover with a soft cloth or sponge dampened with water and mild detergent. Rinse with clean water.
7. If necessary, clean the faucet and drip tray (see page 8).
8. Allow all components to air dry, then reassemble.

Procedure is complete

TROUBLESHOOTING SUGGESTIONS

SYMPTOM	POSSIBLE CAUSE	SUGGESTED REMEDY
Appliance will not heat	Not plugged in or circuit breaker off or tripped	Restore electric power to warmer
	Power switch not <i>ON</i>	Turn power switch to <i>ON</i>
	Internal wiring damage	Inspect wiring for burnt wires and proper connections . Repair as needed
	Power cord damaged	Replace power cord
	Thermostat damaged	Replace thermostat
	Power switch damaged	Replace power switch
"Ready" light does not glow (dispenser operational)	Light or wiring damaged	Replace light and/or repair wiring
	Thermostat damaged	Replace thermostat
"Ready" light always glows	Thermostat damaged	Replace thermostat
Faucet leaks	Faucet seat contaminated	Clean faucet
	Faucet seat cup damaged	Replace seat cup

EXPLODED VIEW & PARTS LIST

MODEL HD8799 2½-GALLON DISPENSER

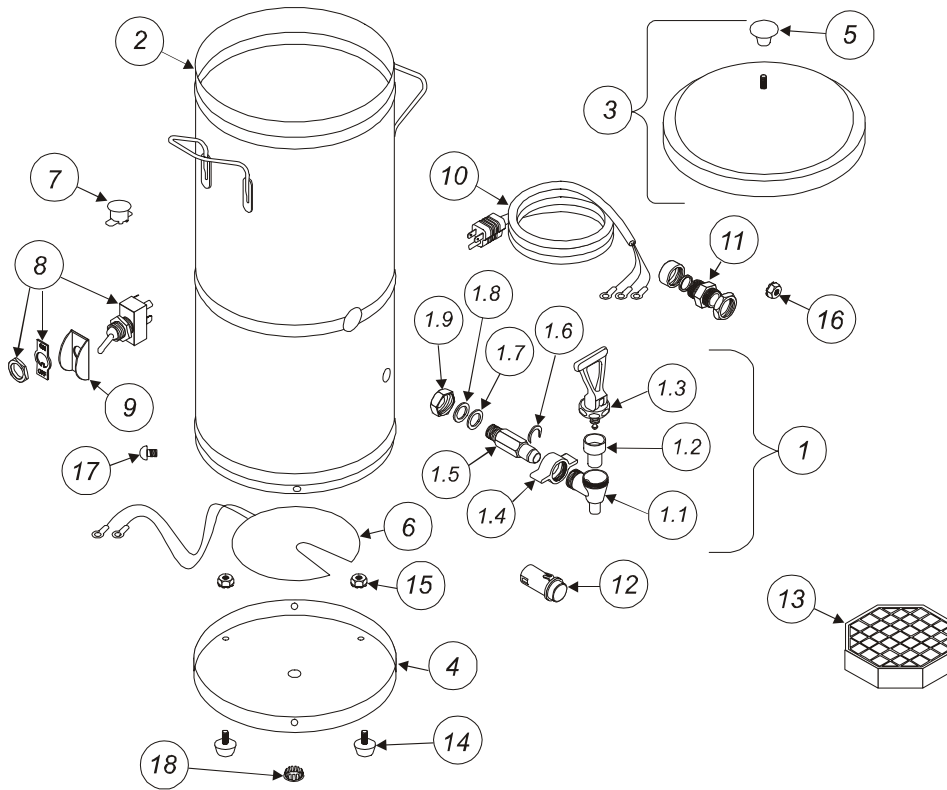

ITEM	PART #	DESCRIPTION	QTY	ITEM	PART #	DESCRIPTION	QTY
1	85865	FAUCET ASSEMBLY	1	6	85853	HEATING ELEMENT 120V 200W	1
1.1*		BODY FAUCET		7	85863	THERMOSTAT 140°F 120V	1
1.2*	8700-25L	SEAT CUP		8	50169	SWITCH 250V DPST	1
1.3*		ASSEMBLY, HANDLE & PLUNGER		9	65174	GUARD, SWITCH	1
1.4*	8600-27	NUT RETAINING WINGED		10	80017	POWER CORD, 120V NEMA5-15P, 6'	1
1.5*		SHANK, FAUCET W/O SIGHT GLASS		11	68689	STRAIN RELIEF 120V STRAIGHT	1
1.6*	8600-26	C CLIP, FAUCET RETAINING		12	8718-31	LIGHT, SIGNAL GREEN 120V	1
1.7	8600-12	WASHER FLAT NYLON		13	8855-1	ASSEMBLY, DRIP TRAY (pk 6)	1
1.8*		SEAL, O-RING		14	65728	FOOT RUBBER #8-32 THREAD	4
1.9	8600-50	FITTING, FAUCET NUT		15	51053	NUT #8-32 KEP	4
2	85862	ASSEMBLY, TANK BODY	1	16	55736	NUT #8-32 KEP GREEN	1
3	8600-6	ASSEMBLY, TANK COVER	1	17		SCREW PAN PHL #6 x 3/8 DRILL POINT	6
4	85876	PANEL, TANK BOTTOM		18	8033-60	BUTTON PLUG 3/8"	1
5	8600-7	KNOB, TANK COVER	1				

* included in 85865 FAUCET ASSEMBLY

EXPLODED VIEW & PARTS LIST

MODEL HD8802 5-GALLON DISPENSER

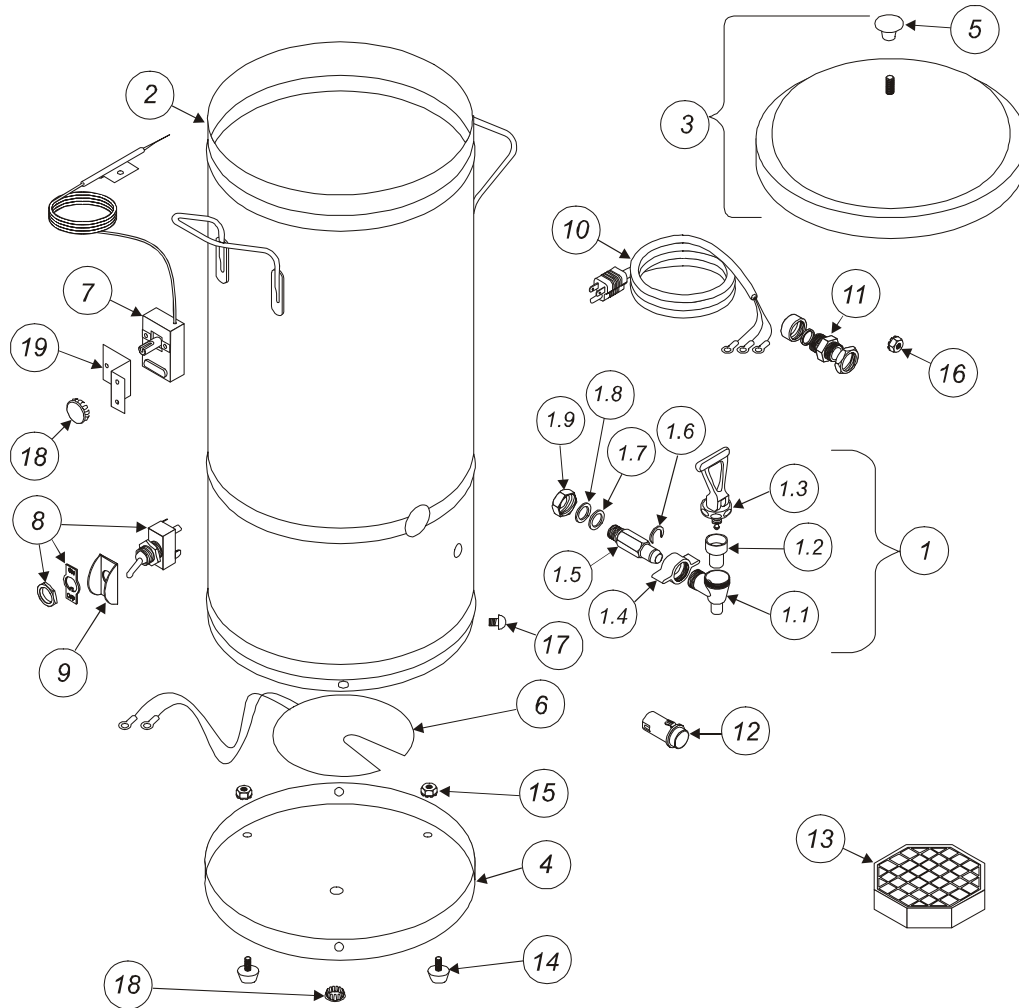

ITEM	PART #	DESCRIPTION	QTY	ITEM	PART #	DESCRIPTION	QTY
1	85865	FAUCET ASSEMBLY	1	6	85853	HEATING ELEMENT 120V 200W	1
1.1*		BODY FAUCET		7	504682	THERMOSTAT ADJUST 170°F 120V	1
1.2*	8700-25L	SEAT CUP		8	50330	SWITCH 250V DPST	1
1.3*		ASSEMBLY, HANDLE & PLUNGER		9	65174	GUARD, SWITCH	1
1.4*	8600-27	NUT RETAINING WINGED		10	80017	POWER CORD, 120V NEMA5-15P, 6'	1
1.5*		SHANK, FAUCET W/O SIGHT GLASS		11	68689	STRAIN RELIEF 120V STRAIGHT	1
1.6*	8600-26	C CLIP, FAUCET RETAINING		12	8718-31	LIGHT, SIGNAL GREEN 120V	1
1.7	8600-12	WASHER FLAT NYLON		13	8855-1	ASSEMBLY, DRIP TRAY (pk 6)	1
1.8*		SEAL, O-RING		14	65728	FOOT RUBBER #8-32 THREAD	4
1.9	8600-50	FITTING, FAUCET NUT		15	51053	NUT #8-32 KEP	4
2		ASSEMBLY, TANK BODY	1	16	55736	NUT #8-32 KEP GREEN	1
3	8601-5	ASSEMBLY, TANK COVER	1	17	83457	SCREW PAN PHL #6 x 3/8 DRILL POINT	6
4	506099	PANEL, TANK BOTTOM		18	8033-60	BUTTON PLUG 3/8"	2
5	8600-7	KNOB, TANK COVER	1	19	506100	BRACKET, THERMOSTAT MOUNTING	1

* included in 85865 FAUCET ASSEMBLY

595 p/n 75982 OpM Heated Dispenser

SERVICING INSTRUCTIONS



CAUTION Electric Shock Hazard

Opening the bottom panel will expose uninsulated electrical components. Disconnect dispenser from electrical power before removing bottom panel.

ACCESS - BOTTOM PANEL

All internal components are accessible by removing the bottom panel.

Remove four screws around the bottom of the warmer tank to free bottom panel from tank assembly.

FAUCET

The faucet may be removed from the shank by turning the winged collar clockwise.

The faucet bonnet may be removed by turning the bonnet nut counterclockwise.

The seat cup snaps onto the end of the faucet stem.

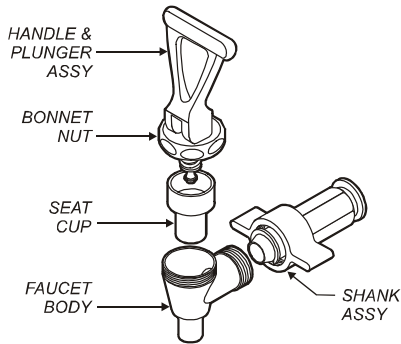

Faucet Assembly

DRIP TRAY

The grate sets in the drip tray base, and may be lifted out.

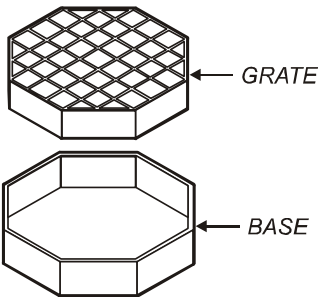

Drip Tray Assembly

WIRING DIAGRAM

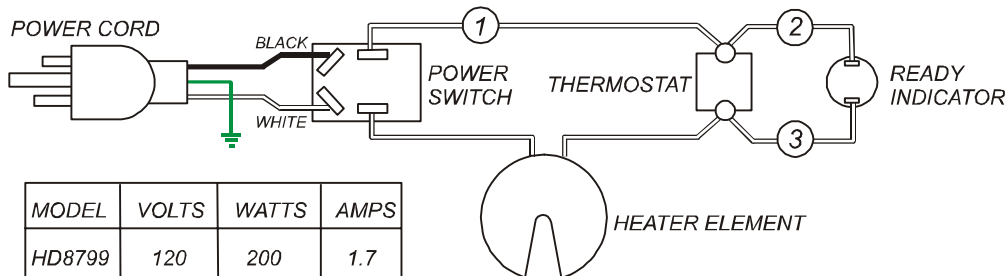

MODEL	VOLTS	WATTS	AMPS
HD8799	120	200	1.7
HD8802	120	200	1.7

ISSUE A 75868

DESCRIPTION

PART NO.

DRIP TRAY ASSEMBLY (pk 6)

8855-1

IMPORTANT: Use only factory authorized service parts and replacement filters.

For factory authorized service, or to order factory authorized replacement parts, contact your Wells authorized service agency, or call:

Wells Bloomfield, LLC

2 Erik Circle
P. O. Box 280
Verdi, NV 89439

Service Parts Dept.
phone: (775) 689-5707
fax: (775) 689-5976

Service Parts Department can supply you with the name and telephone number of the **WELLS AUTHORIZED SERVICE AGENCY** nearest you.

CUSTOMER SERVICE DATA

please have this information available if calling for service

RESTAURANT _____ LOCATION _____

INSTALLATION DATE _____ TECHNICIAN _____

SERVICE COMPANY _____

ADDRESS _____ STATE _____ ZIP _____

TELEPHONE NUMBER (____) _____ - _____

EQUIPMENT MODEL NO. _____

EQUIPMENT SERIAL NO. _____

VOLTAGE: (check one) 120

595 p/n 75982 OpM Heated Dispenser



Wells Bloomfield proudly supports CFESA
Commercial Food Equipment Service Association

SERVICE TRAINING - QUALITY SERVICE



CUSTOMER SATISFACTION



WELLS BLOOMFIELD, LLC
2 ERIK CIRCLE, P. O. Box 280 Verdi, NV 89439
telephone: 775-689-5703
fax: 775-689-5976
www.wellsbloomfield.com

PRINTED IN UNITED STATES OF AMERICA