

OWNER'S MANUAL

**MODEL NO.
625.345500**

Caution:
Read and Follow
All Safety Rules,
Installation and
Operating
Instructions
Before First Use
of This Product.

If you have questions
when installing and us-
ing your countertop wa-
ter filter system, call this
toll-free number...

1 - 800 - 426 - 9345

SAVE THIS MANUAL

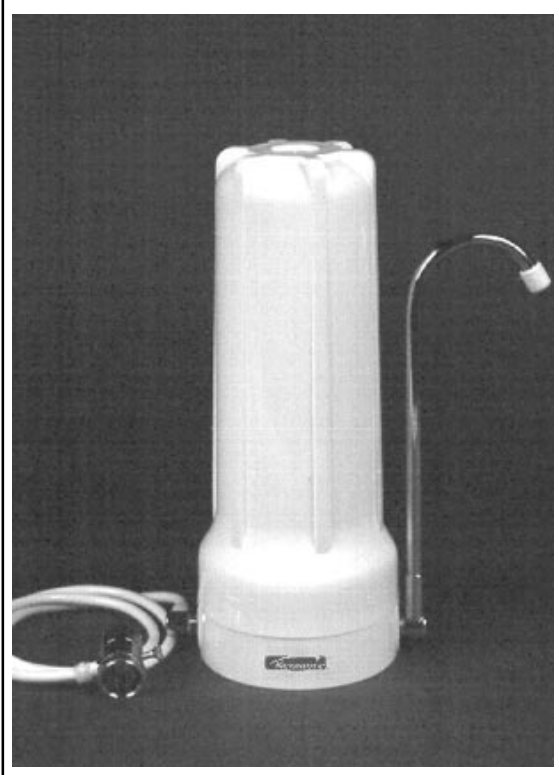

COUNTERTOP WATER FILTER

- ◆ Safety Guides
- ◆ Connection
- ◆ Operation
- ◆ Service
- ◆ Repair Parts

Sears, Roebuck and Co., Hoffman Estates, IL 60179 USA



WARRANTY

FULL ONE YEAR WARRANTY ON COUNTERTOP WATER FILTER (Except Carbon Cartridge)

For one year from the date of purchase, Sears will replace this Countertop Water Filter, (except carbon cartridge), free of charge, if defective in material or workmanship.

WARRANTY SERVICE IS AVAILABLE BY SIMPLY RETURNING THE COUNTERTOP WATER FILTER TO THE NEAREST SEARS STORE THROUGHOUT THE UNITED STATES.

This warranty gives you specific legal rights, and you may have other rights which vary from state to state.

Sears, Roebuck and Co., DEPT. 817 WA, Hoffman Estates, IL 60179

PARTS INCLUDED

Your Kenmore Countertop Water Filter consists of the following parts.

- (1) Filter Assembly with water supply tubing and spout
- (2) Activated carbon filter cartridge
- (3) A parts bag containing adaptors and gaskets for the diverter valve

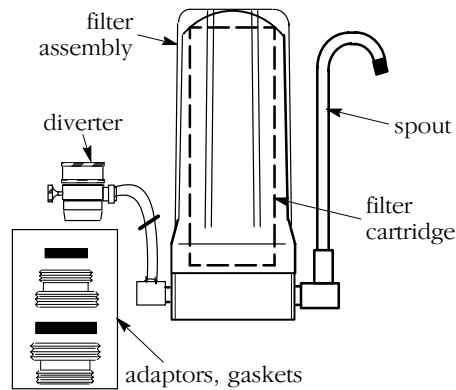

SAFETY GUIDES / SPECIFICATIONS

√ Be sure to follow all guides in this manual when connecting and using the filter, and when servicing the inner cartridge.

√ Follow state and local plumbing codes as you install the filter. Use their codes if they are different than guides in this manual.

√ Use the filter on a potable, safe-to-drink, house water supply only. The activated carbon car-

tridge will not purify water, or make it safe to drink. DO NOT use on microbiologically unsafe water, or on water of unknown quality.

√ Do not set the water filter near the edge of the counter where it could fall to the floor and break.

√ Maximum water pressure to filter- 125psi. Maximum water temperature is 100 °F.

WHAT YOUR COUNTERTOP FILTER WILL DO

Activated carbon is a mineral having a great ability to adsorb and hold tastes and odors. It is used to remove many different bad tastes and/or odors from drinking water. Some of these are chlorine, metallic, marshy or swampy taste/odor. Small amounts of hydrogen sulfide (noticeable as “rotten egg” odor) may be reduced by taste and odor filters for a short time, quickly exhausting the carbon media. Consult your Sears store for proper continuous treatment.

The cartridge in your water filter is filled with activated carbon. A diverter valve, included with the filter, connects to the kitchen or bathroom faucet. When the cold faucet and diverter valve are opened, water is di-

rected to the filter assembly. Water passes through the carbon cartridge to provide you with fresh tasting, clean smelling drinking water.

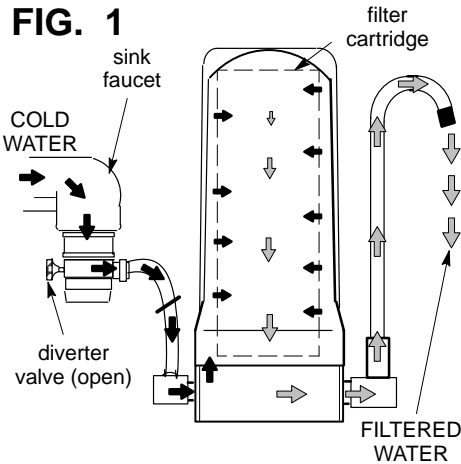

WASH THE FILTER BEFORE USING

The water filter is cleaned and packaged at the factory. However, after shipment and storage, do the following to be sure it is still clean.

1. Remove the filter sump, turning it to the right (FIG. 2).
2. Lift the carbon cartridge out and set aside.
3. Wash the entire filter, inside and out, with warm water and mild dishwashing detergent. Rinse with fresh faucet water.
4. Replace the carbon cartridge in the sump.
5. Be sure the o-ring seal is in place and fully seated in the groove. Lubricate it with food grade silicone grease or Vaseline if it is dry.
6. Turn the sump onto the filter head and tighten.

FIG. 2

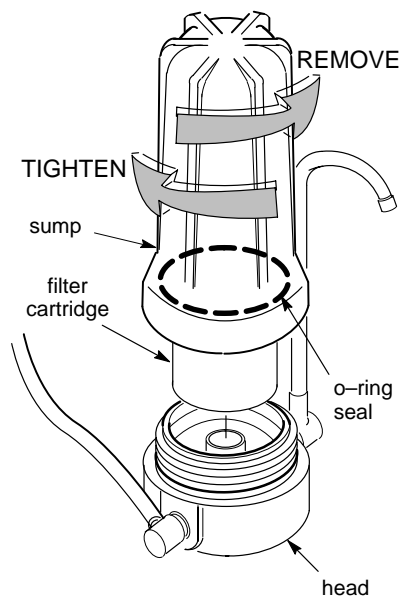

CONNECT THE FILTER TO A FAUCET

1. Remove the aerator from the faucet, FIG. 3A.
2. Looking at FIG. 3B or 3C, as applies, install and tighten the diverter valve as follows. The top of the diverter turns, like the end fitting on a garden hose.

B. Install diverter only, directly to **external** faucet threads.

C. Install diverter and adaptor, with gasket (2 sizes included), to **internal** faucet threads. Use the adaptor and gasket that fits your faucet.

Note: Most hardware stores have other adaptors to fit different types of faucets.

3. Place the filter in the desired location on the countertop (the filter has a 3 ft water supply tubing length). Route the supply tubing out of the way.

FIG. 3

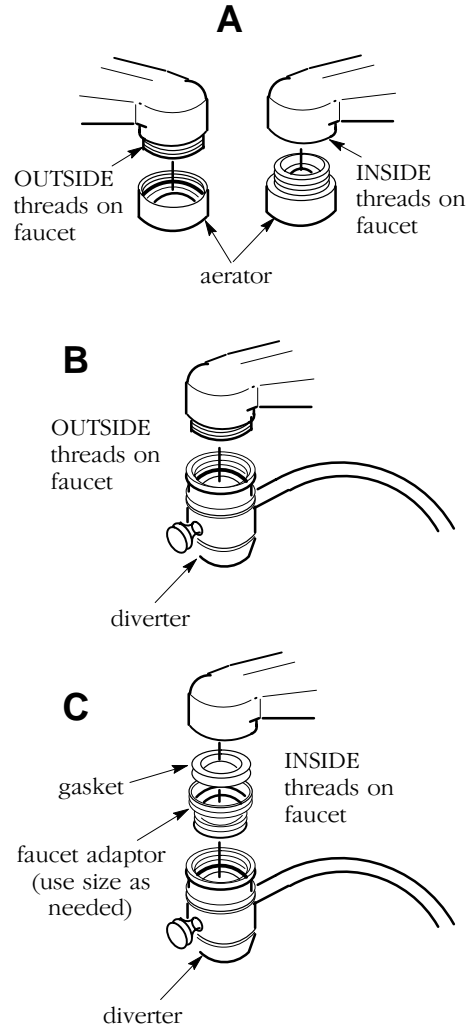

USING YOUR COUNTERTOP WATER FILTER

- ◆ Set a glass, cup, pitcher, or other container under the filter spout. The spout rotates to any desired position.
- ◆ Open the COLD water faucet and adjust to a medium flow.
- ◆ Pull the diverter knob outward to direct water to the filter.
- ◆ When the container is full of filtered water, close the cold water faucet. Then, be sure the diverter valve has closed (knob inward).

CAUTION: Do not direct hot water into the countertop filter. Always

be sure the diverter valve knob is inward (closed) before opening the sink hot water faucet.

CAUTION: Do not force the diverter knob inward while the cold water faucet is open. Always close the faucet first, to prevent damaging the diverter.

Note: The first time you use the filter, and whenever you change the carbon cartridge, discard the first 2-3 glasses of filtered water. The filtered water may contain some harmless carbon particles (“fines”) from the new cartridge.

FIG. 4

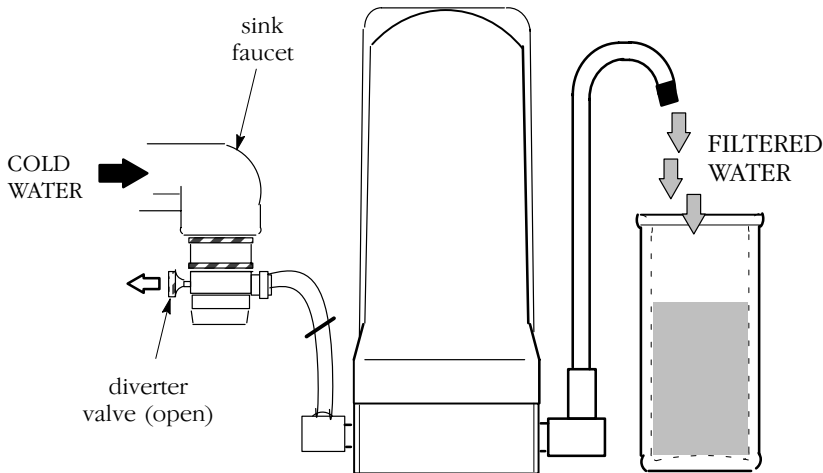

REPLACING THE CARBON FILTER CARTRIDGE

The replaceable carbon cartridge is good for up to 1500 gallons of filtered water, or up to 6 months. If the water supply to your house is poor quality, the cartridge may not last that long. Always replace the cartridge after:

- ① you notice the return of bad taste and/or odor in the filtered water.
- ② 6 months
- ③ a reduced water flow is noticeable.

continued



REPLACING THE CARBON FILTER CARTRIDGE (cont.)

To replace the cartridge, do steps 1 – 6 on page 3. Be sure to clean the inside of the sump. Cleaners are available from Sears (see the parts list on page 7), or use hot, soapy water. After

replacing the cartridge, discard the first few cupfuls of filtered water which may contain harmless carbon fines (see note on page 5).

SERVICE CHECK LIST

Filtered water has bad taste and/or odor. – The carbon cartridge needs replacing.

Fine, black particles in filtered water. – This is harmless carbon “fines” from a new cartridge. Discard the first few cupfuls of filtered water after changing the cartridge.

No water flow from the filter. – Cold water faucet and/or diverter valve not opened.
– Supply tubing, from diverter valve to filter, pinched or plugged.
– The carbon cartridge needs replacing.



REPAIR PARTS

KENMORE COUNTERTOP WATER FILTER MODEL NO. 625.345500

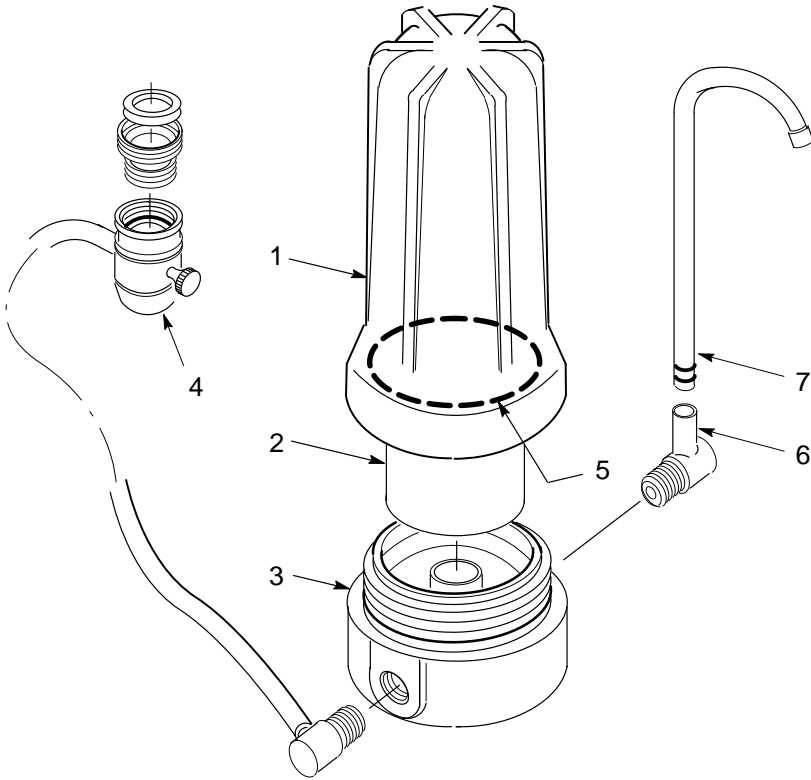

KEY NO.	PART NUMBER	DESCRIPTION OF PART
1	7160500	Sump
2	42-34370	Carbon Filter Cartridge
3	7183273	Filter Head
4	7160518	Diverter
5	42- 34385	O-ring Seal, 3-3/8" I.D. x 3-5/8" O.D.
6	7160526	Elbow
7	7160534	Spout
◆	7183299	Owners Manual
♣	42-34330	Sump Cleaning Kit
♣	42-34331	Sump Cleaning Solution
♣	42-34334	Sump Removal Wrench

◆ not illustrated

♣ available options from Sears

OWNER'S MANUAL

**MODEL NO.
625.345500**

The model number of your drinking water filter system is found on the rating decal, on the mounting bracket .

When requesting service or ordering parts, always provide the following information:

- ◆ Product Type
- ◆ Model Number
- ◆ Part Number
- ◆ Part Description



COUNTERTOP WATER FILTER

For the repair or replacement parts you need

Call 7 am – 7 pm, 7 days a week

1 – 800 – 366 – PART

(1 – 800 – 366 – 7278)

For in-home major brand repair service

Call 24 hours a day, 7 days a week

1 – 800 – 4 – REPAIR

(1 – 800 – 473 – 7247)

For the location of a

Sears Repair Service Center in your area

Call 24 hours a day, 7 days a week

1 – 800 – 488 – 1222

**For information on purchasing a Sears
Maintenance Agreement, or to inquire
about an existing Agreement**

Call 9 am – 5 pm, Monday – Saturday

1 – 800 – 827 – 6655

Sears, Roebuck and Co., Hoffman Estates, IL 60179 USA

7183299 (5/97)

