

Symphony™ countertop and wall mount ice and water dispensers with Maestro™ Chewblet® icemaker

50 Series

Countertop models with (A) air- or (W) water-cooled icemaker

- 50CT400A/W – 115V, 60Hz, integral icemaker
- 50CR400A/W – 115V, 60Hz, Satellite-fill icemaker
- C50CT400A/W – 220V, 60Hz, integral icemaker
- C50CR400A/W – 220V, 60Hz, Satellite-fill icemaker
- E50CT400A/W – 230V, 50Hz, integral icemaker
- E50CR400A/W – 230V, 50Hz, Satellite-fill icemaker

Wall mount models with (A) air- or (W) water-cooled icemaker

- 50HT400A/W – 115V, 60Hz, integral icemaker
- 50HR400A/W – 115V, 60Hz, Satellite-fill icemaker
- C50HT400A/W – 220V, 60Hz, integral icemaker
- C50HR400A/W – 220V, 60Hz, Satellite-fill icemaker
- E50HT400A/W – 230V, 50Hz, integral icemaker
- E50HR400A/W – 230V, 50Hz, Satellite-fill icemaker



Countertop model shown with SensorSAFE accessory

Symphony™

Countertop and wall mount ice and water dispensers with air- or water-cooled icemaker. Stainless steel frame and exterior with plastic trim. Up to 50 lbs (23kg) storage. Produces approximately 400 lbs (181kg) of Chewblet compressed nugget ice in a 24-hour period.

Convenient, sanitary, user-friendly dispensing

- Labor-saving, sanitary automatic load
- Lever dispensing standard
- Quick shut-off reduces the amount of wasted ice
- High-quality Chewblet compressed nugget ice is slow melting, easy to chew
- Clear chute ensures sanitary delivery and focuses ice cleanly into cups, pitchers, carafes, ice bags

SensorSAFE™ accessory offers even more sanitation and convenience

- Infrared sensing eliminates container to dispenser contact, reduces chance of cross-contamination
- Easy, one-hand filling of containers
- Attractive graphics direct users to actuation zone

Space-saving, attractive design

- 21" (534mm) width requires less space than competitive models of similar capacity
- Zero side clearance required for ventilation
- Softly-rounded European styling
- High-quality stainless steel exterior with plastic trim
- Attractive, user-friendly graphics

Environmentally-friendly Maestro icemakers

- State-of-the-art R404A icemaker automatically loads dispenser with 400 lbs (181kg) of ice each day
- Stainless steel evaporator and auger
- Energy-efficient; no costly defrost cycles or high waste water
- Quiet production; no noisy harvest cycles
- Satellite-fill™ icemakers can be located up to 20 feet (6m) from dispenser; remove heat, noise and bulk from customer area

Accessories

- SensorSAFE actuation (standard on wall mount models)
- Chilled water option (item# AFH20CHIL2550)
- Water filter kit (item# 00130229)
- Base stand (for models 50CT400A/W, C/E50CT400A/W) (item# AF50BASESTD)
- SafeCLEAN™ environmentally-responsible ice machine cleaner (item# 00132001)
- Slide-out track for Satellite-fill icemakers (item# AFGSLIDER400A (air-cooled icemakers) and item# AFGSLIDER400W (water-cooled icemakers))
- Drain pan assembly for wall mount models (item# AFH50WBASE)

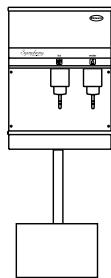

Countertop model with Satellite-fill icemaker

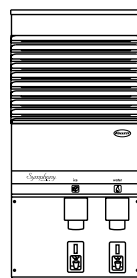

Wall mount model with integral icemaker*

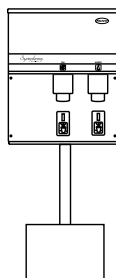

Wall mount model with Satellite-fill icemaker*

* No drain pan. Drain pan available – contact factory.

50 Series

Symphony™ countertop and wall mount ice and water dispensers with Maestro™ Chewblet® icemaker

Models with Satellite-fill Icemaker

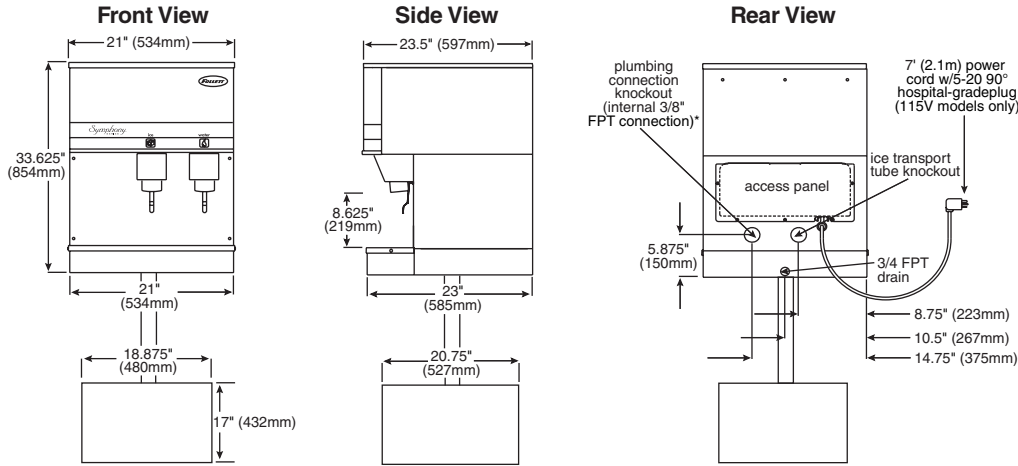

Ice Production

Air-cooled icemaker capacity/24 hrs.

		Ambient Air Temperature F/C					
		60	70	80	90	100	
Inlet Water Temperature F/C	C	16	21	27	32	38	
	F	60	70	80	90	100	
50	16	219	198	177	150	123	lbs.
10	16	219	198	177	150	123	kg.
60	16	219	198	177	150	123	lbs.
16	16	219	198	177	150	123	kg.
70	16	219	198	177	150	123	lbs.
21	16	219	198	177	150	123	kg.
80	16	219	198	177	150	123	lbs.
27	16	219	198	177	150	123	kg.
90	16	219	198	177	150	123	lbs.
32	16	219	198	177	150	123	kg.

Water-cooled icemaker capacity/24 hrs.

		Ambient Air Temperature F/C					
		60	70	80	90	100	
Inlet Water Temperature F/C	C	16	21	27	32	38	
	F	60	70	80	90	100	
50	16	192	187	185	181	179	lbs.
10	16	192	187	185	181	179	kg.
60	16	192	187	185	181	179	lbs.
16	16	192	187	185	181	179	kg.
70	16	192	187	185	181	179	lbs.
21	16	192	187	185	181	179	kg.
80	16	192	187	185	181	179	lbs.
27	16	192	187	185	181	179	kg.
90	16	192	187	185	181	179	lbs.
32	16	192	187	185	181	179	kg.

Models with Integral Icemaker

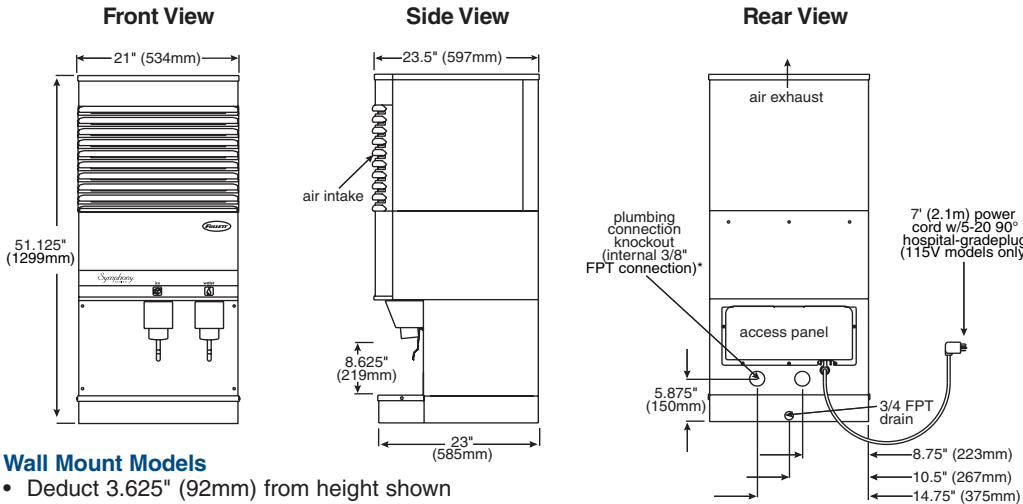

Heat Rejection Data

Model	Heat rejected in BTU/hr	
	to air	to water
Air-cooled	5000	n/a
Water-cooled	1400	3600

Plug Configuration



* Kit provided with all 230V, 50Hz and 220V, 60Hz models to connect to BSP water fittings.

Wall Mount Models

- Deduct 3.625" (92mm) from height shown
- Add .5" (13mm) to depth shown
- Wall mount bracket standard
- SensorSAFE standard
- No drain pan. Drain pan available – contact factory.

Connections Utilities connect through back or bottom. Back entry shown. Supplied 2" (51mm) duct and louver must be installed for undercounter Satellite-fill icemaker installations.

Required Clearances

- Models with integral icemakers – 6" (153mm) at top for ventilation, 12" (305mm) recommended for service
- Models with Satellite-fill icemakers – 12" (305mm) at top recommended for service
- See Dispenser Detail Sheet, form# 2075, for important installation information

Electrical

Standard electrical – 115V, 60Hz, 1 phase. Icemaker 11 amps, dispenser 4 amps. Cord and plug provided with each icemaker and dispenser. If local code requires hard-wiring, separate disconnects also required. Satellite-fill icemaker models require separate circuits for icemaker and dispenser.

Alternate electrical – 220V, 60Hz, 1 phase, 6.5 amps (icemaker 5 amps). 230V, 50Hz, 1 phase, 6.5 amps (icemaker 5 amps). Cord only provided with each icemaker and dispenser. Wire in accordance with all local codes.

Plug configuration – 7 ft (2.1m) cord and NEMA 5-20 hospital-grade plug provided with each dispenser. 220V/230V models, cord only.

Approximate Shipping Weight

C/E/50CT400A/W	295 lbs (134kg)	C/E/50HT400A/W	310 lbs (141kg)
C/E/50CR400A/W	250 lbs (113kg)	C/E/50HR400A/W	295 lbs (134kg)

Chewblet is a registered trademark of Follett Corporation, registered in the US.

Follett reserves the right to change specifications at any time without obligation. Certifications may vary depending on country of origin.