

Super Audio CD Player

Operating Instructions_____

US

Mode d'emploi_____

FR



SCD-XA9000ES

WARNING

To prevent fire or shock hazard, do not expose the unit to rain or moisture.

To prevent fire, do not cover the ventilation of the apparatus with news papers, tablecloths, curtains, etc. And don't place lighted candles on the apparatus.

To prevent fire or shock hazard, do not place objects filled with liquids, such as vases, on the apparatus.

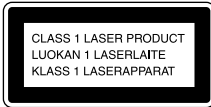

This appliance is classified as a **CLASS 1 LASER** product. This marking is located on the rear exterior.

For the customers in the United States

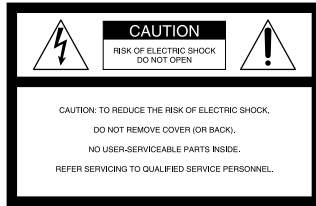

This symbol is intended to alert the user to the presence of uninsulated "dangerous voltage" within the product's enclosure that may be of sufficient magnitude to constitute a risk of electric shock to persons.



This symbol is intended to alert the user to the presence of important operating and maintenance (servicing) instructions in the literature accompanying the appliance.

WARNING

This equipment has been tested and found to comply with the limits for a Class B digital device, pursuant to Part 15 of the FCC Rules. These limits are designed to provide reasonable protection against harmful interference in a residential installation. This equipment generates, uses, and can radiate radio frequency energy and, if not installed and used in accordance with the instructions, may cause harmful interference to radio communications. However, there is no guarantee that interference will not occur in a particular installation. If this equipment does cause harmful interference to radio or television reception, which can be determined by turning the equipment off and on, the user is encouraged to try to correct the interference by one or more of the following measures:

- Reorient or relocate the receiving antenna.
- Increase the separation between the equipment and receiver.
- Connect the equipment into an outlet on a circuit different from that to which the receiver is connected.
- Consult the dealer or an experienced radio/TV technician for help.

CAUTION

You are cautioned that any changes or modification not expressly approved in this manual could void your authority to operate this equipment.

Owner's Record

The model and serial numbers are located on the rear of the unit.

Record the serial number in the space provided below. Refer to them whenever you call upon your Sony dealer regarding this product.

Model No. SCD-XA9000ES

Serial No. _____

CAUTION

The use of optical instruments with this product will increase eye hazard.

For the customers in Canada

This Class B digital apparatus complies with Canadian ICES-003.

CAUTION

TO PREVENT ELECTRIC SHOCK, MATCH WIDE BLADE OF PLUG TO WIDE SLOT, FULLY INSERT.



Don't throw away the battery with general house waste, dispose of it correctly as chemical waste.

Welcome!

Thank you for purchasing the Sony Super Audio CD Player. Before operating the unit, please read this manual thoroughly and retain it for future reference.

About This Manual

The instructions in this manual is for SCD-XA9000ES.

Conventions

- Instructions in this manual describe the controls on the player. You can also use the controls on the remote if they have the same or similar names as those on the player.
- The following icons are used in this manual:



Indicates that you can do the task using the remote.



Indicates hints and tips for making the task easier.

Features

About the Super Audio CD

- Super Audio CD is a new high-quality audio disc standard where music is recorded in the DSD (Direct Stream Digital) format (conventional CDs are recorded in the PCM format). The DSD format, using a sampling frequency 64 times higher than that of a conventional CD, and with 1-bit quantization, achieves both a wide frequency range and a wide dynamic range across the audible frequency range, and so provides music reproduction extremely faithful to the original sound.
- The Super Audio CD has two types; a 2 channel stereo disc and a Multi-channel disc which holds up to 6 independent channels. The multi-channel characteristic of the Super Audio CD features a speaker allocation system basically similar to the 5.1 channel output of current AV systems.

Features of the player

This player is designed to play back 2-channel and multi-channel Super Audio CDs, and conventional CDs, and provides the following features:

- Mounted with a Discrete Dual Laser Optical Pickup, capable of reading a Super Audio CD or conventional CD depending on the exclusive wavelength.
- Quicker track access performance enabled by an advanced servo mechanism.
- A Multi-Channel Management function that allows you to adjust the multi-channel playback environment according to the allocation and size of your speakers.
- A Super Audio D/A Converter and Direct Digital Sync System, which allows higher-quality sound reproduction.
- An i.LINK digital transmission system that provides higher quality sound and lets you make connections with just 1 i.LINK cord instead of 6 pin cords.
- This player complies with DTLA copy protection technology (Revision 1.2).

Others

- A Super Audio CD can mark up to 255 track/index numbers. This feature applies to SCD-XA9000ES.
- The supplied remote is capable of controlling both the SCD-XA9000ES and a conventional Sony CD player.

TABLE OF CONTENTS

Getting Started 4

- Before You Start the Hooking Up 4
- Hooking Up the Audio Components 5

Location and Functions of Parts 10

- Front Panel Parts Descriptions 10
- Rear Panel Parts Descriptions 12
- Remote Parts Descriptions 13

Playing Discs 14

- Compatible Disc Types 14
- Playing a Disc 16
- Using the Display 17
- Locating a Specific Track 20
- Locating a Particular Point in a Track 20
- Playing Tracks Repeatedly 21
- Playing Tracks in Random Order (Shuffle Play) 22
- Creating Your Own Program (Program Play) 23
- Listening to a CD Using a Filter (Digital Filter Function) 24

US

Getting Started

This chapter provides information on the supplied accessories and how to connect various audio components to the Super Audio CD player. Be sure to read this chapter thoroughly before you actually connect anything to the player.

Before You Start Hooking Up

Checking the supplied accessories

This player comes with the following items:

- Audio connecting cord
 - phono jack × 2 (Red and White) ↔ phono jack × 2 (Red and White) (3)
 - phono jack × 1 (Black) ↔ phono jack × 1 (Black) (2)
- i.LINK connecting cord (1)
- Remote commander RM-SX700 (1)
- Size AA (R6) batteries (2)
- AC power cord (1)
- Plug adapter (1)

Inserting batteries into the remote

Insert two size AA (R6) batteries into the battery compartment with the + and – correctly oriented to the markings. When using the remote, point it at the remote sensor  on the player.

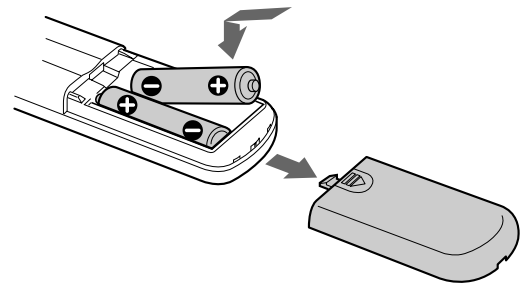

When to replace the batteries

Under normal conditions, the batteries should last for about six months. When the remote no longer operates the player, replace both batteries with new ones.

Notes

- Do not leave the remote in an extremely hot or a humid place.
- Do not drop any foreign object into the remote casing, particularly when replacing the batteries.
- Do not use a new battery with an old one.
- Do not expose the remote sensor to direct sunlight or lighting apparatus. Doing so may cause a malfunction.
- If you do not intend to use the remote for an extended period of time, remove the batteries to avoid possible damage from battery leakage and corrosion.

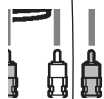
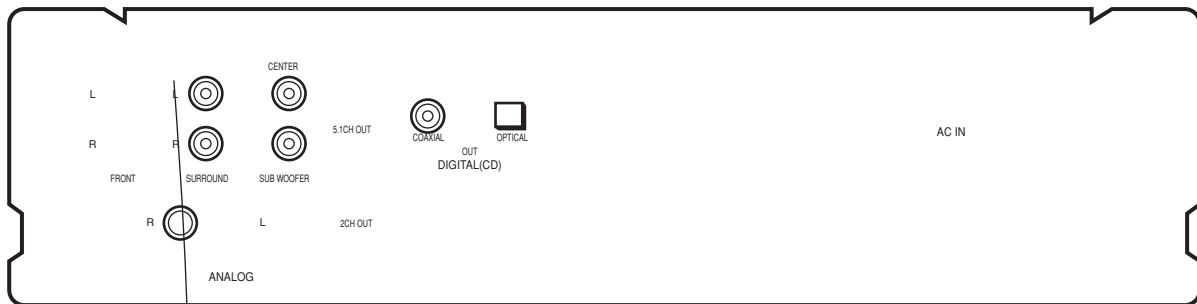

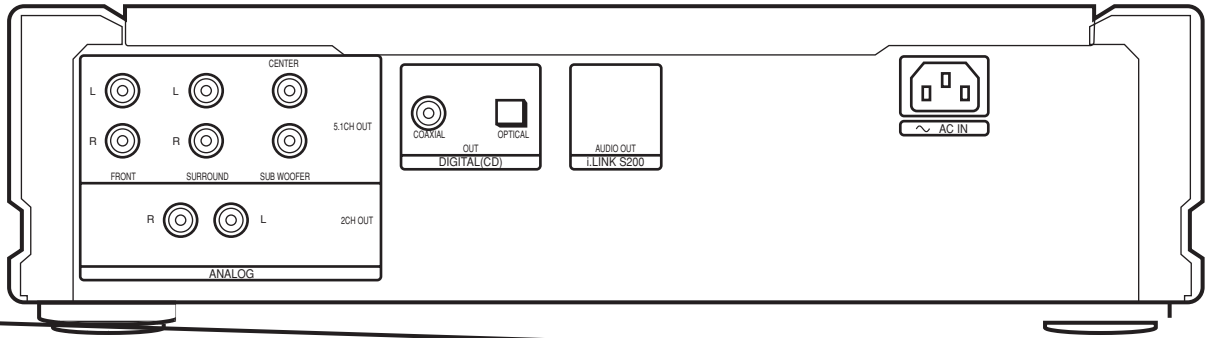

Connecting via i.LINK S200 AUDIO OUT jack

Connect SCD-XA9000ES to STR-DA9000ES/TA-DA9000ES with the supplied i.LINK connecting cord.

i.LINK connecting cord (supplied)

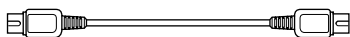

Notes

- i.LINK connections are only possible between this player and STR-DA9000ES/TA-DA9000ES. This player has some restrictions on i.LINK functions and may not operate properly if connected to components other than STR-DA9000ES/TA-DA9000ES.
- If a metal object should fall into the i.LINK S200 AUDIO OUT jack, short-circuiting may occur and damage the components.
- Be sure to insert the plug firmly to prevent malfunction.
- See page 32 for information about compatible signals.
- Some i.LINK components comply with copy protection technology and handle encrypted signals. This player complies with the DTLA copy protection technology (Revision 1.2).
- "i.LINK" lights up in the display when this player is ready to output the audio signals from the i.LINK S200 AUDIO OUT jack.

Establishing a LINC

Before an audio signal can be transmitted between i.LINK components, a LINC (Logical Interface Connection) must first be established between the receiving component (of the audio signal) and the sending component. Establishing a LINC means establishing a logical path for the transmission of digital audio signals between the two components. Each logical path has an ID number. Since the component that sends an audio signal must output the signal to a path, and the component that receives the signal must input it from the same path, the path must be mutually known by both components. During the establishment of a LINC, the following communication occurs between the two i.LINK components.

Example

STR-DA9000ES/TA-DA9000ES establishes a LINC with SCD-XA9000ES.

- ① STR-DA9000ES/TA-DA9000ES sends a request and path information to SCD-XA9000ES to establish a transmission path for the audio signal.

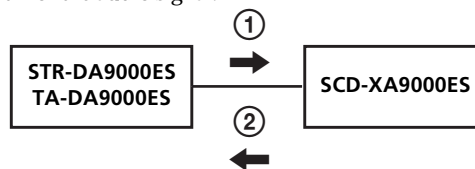

- ② SCD-XA9000ES responds to STR-DA9000ES/TA-DA9000ES, agreeing to the establishment of a LINC. The digital audio signal transmission becomes possible only after the communication described above has occurred and a LINC has been established.

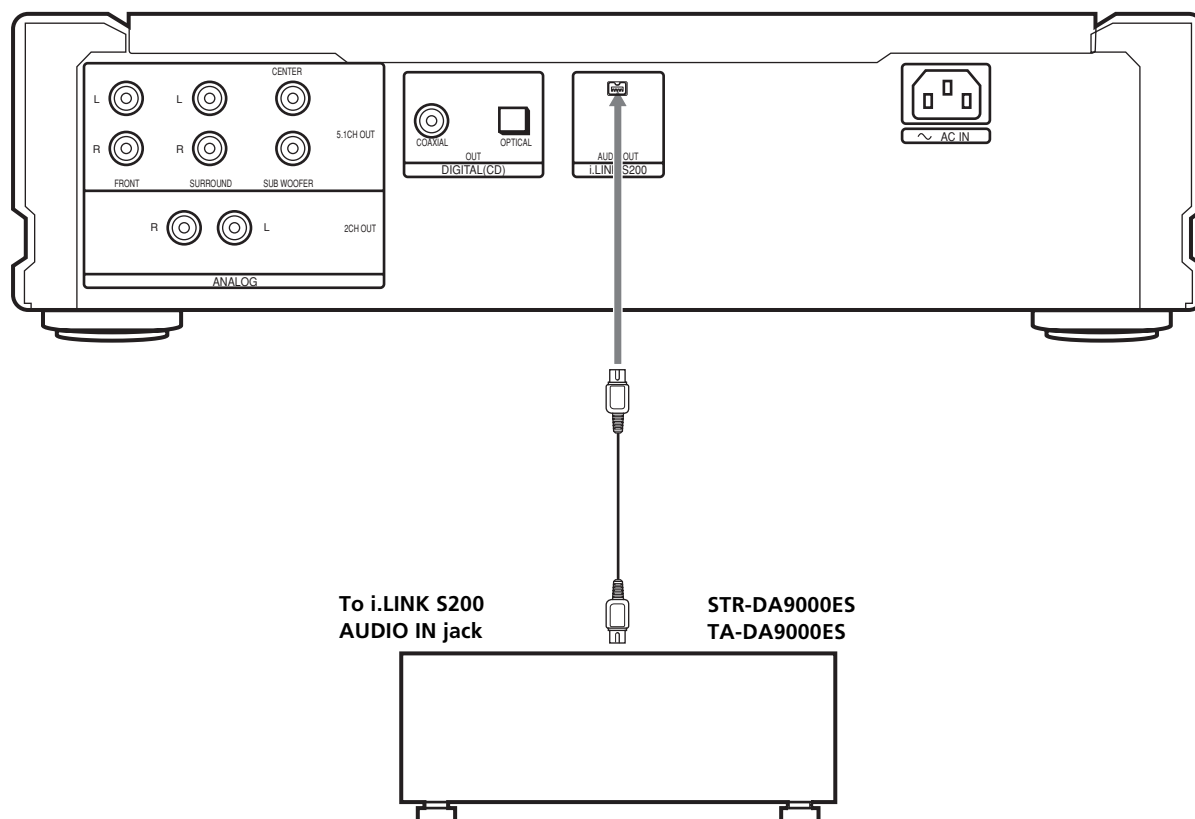

Hooking Up the Audio Components

Listening in high fidelity H.A.T.S. (High quality digital Audio Transmission System) function

When the H.A.T.S. function of STR-DA9000ES/TA-DA9000ES is "ON" digital audio signals are momentarily stored in a buffer, then read with exact timing before being converted to analog. This eliminates the jitter (timing lapses) that sometimes occur during digital signal transmission and greatly improves sound quality. When this function is turned on, the H.A.T.S. indicator on the front panel of STR-DA9000ES/TA-DA9000ES lights up whenever the digital audio signal is input to the receiver. When not using this function, set it to "OFF" on STR-DA9000ES/TA-DA9000ES. For details, refer to the Operating Instructions supplied with STR-DA9000ES/TA-DA9000ES.

Notes

- Because of the way the H.A.T.S. function operates, a slight time lag is introduced between each operation (e.g., pressing play, stop, or pause) and its implementation. The duration of this time lag may be different for CD and Super Audio CD sources.
- The H.A.T.S. function works only with H.A.T.S. compatible components.
- The H.A.T.S. function works only when this player is selected as the input source by a single STR-DA9000ES/TA-DA9000ES. This is because the receiving component (STR-DA9000ES/TA-DA9000ES) controls the rate of digital audio signal transmission from the player. To insure proper signal transmission within the i.LINK configuration, only one component can receive the digital audio signals output from a source component.

Copyright

i.LINK components complying with copyright protection incorporate digital data copy protection technology. One such technology is the DTLA (The Digital Transmission Licensing Administrator) recognized by the Copy Protection Technical Working Group. It may not be possible to make digital copies of copy restricted digital data (video/audio/data) using i.LINK signals between components that comply with the DTLA copy protection technology. In addition, it may not be possible to transfer digital data (video/audio/data) via i.LINK between i.LINK components which comply with DTLA copy protection and i.LINK components which do not.

- i.LINK is a designation referring to IEEE 1394-1995 and IEEE 1394a-2000. i.LINK and the i.LINK logo "i" are trademarks of Sony Corporation.

Connecting via DIGITAL (CD) OUT OPTICAL connector

Use an optical digital cable for this connection. When connecting the optical digital cable to the DIGITAL (CD) OUT OPTICAL connector, take the cap off the connectors and push the cable plugs in until they click into place.

Be careful not to bend or twist the optical cable.

Optical digital cable (not supplied)

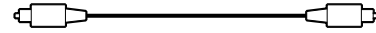

Note

Only the audio signals of conventional CDs can be output from the DIGITAL (CD) OUT connectors. Those of the Super Audio CD cannot be output through DIGITAL (CD) OUT.

When the i.LINK indicator lights up

No signal is output from DIGITAL (CD) OUT OPTICAL connector.

Connecting via DIGITAL (CD) OUT COAXIAL connector

Use a coaxial digital cable to connect the audio components equipped with coaxial digital input connectors.

Coaxial digital cable (not supplied)

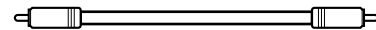

Note

Only the audio signals of conventional CDs can be output from the DIGITAL (CD) OUT connectors. Those of the Super Audio CD cannot be output through DIGITAL (CD) OUT.

When the i.LINK indicator lights up

No signal is output from DIGITAL (CD) OUT COAXIAL connector.

Connecting the AC power cord

Connect the supplied AC power cord to the AC IN terminal on the player and to the mains.

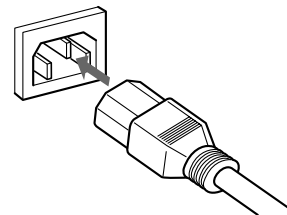

About the AC power cord

The supplied AC power cord has a 3-pronged grounded plug. If you are using 3-pronged grounded mains, the plug can be inserted directly into the mains. However, if the socket is a 2-pronged grounded mains, use the supplied plug adapter or a commercially available plug adapter.

3-pronged grounded mains

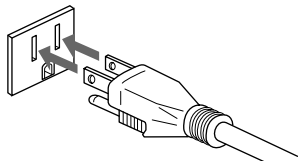

2-pronged polarized mains

- When the width of the mains are a different size Use the supplied plug adapter.

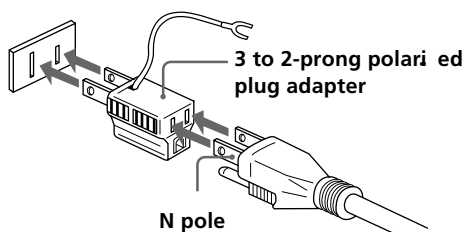

- When the width of the mains are the same size Use a commercially available plug adapter. In this case, you can check the polarity of the mains with a commercially available spark-testing screwdriver. It is the pronged ground that does not light the neon glow lamp even if you insert the spark-testing screwdriver into the mains. Insert the blades so that the "N pole" can be inserted to the ground on the plug.

If noise (hum) is produced

Noise may be caused by an electric potential difference on the ground circuit.* In this case, use the supplied plug adapter and be careful not to connect the ground lead to anything.

- * Although the ground of the domestic mains is normally a safety ground, a few electrical potential differences may be produced, depending on the mains. Therefore, use of the supplied 3-pronged mains lead may lessen the quality of the audio signal or may produce humming noise.

Note on the output jacks

This player is equipped with a Tri-Powered D/A Converter System and a Multi Channel Management function. The usable output settings differ depending on the mode you select as follows. For details, refer to the Operating Instructions.

Source	Multi Channel Management	2CH OUT jacks	5.1CH OUT jacks	PHONES jack	DIGITAL (CD) OUT jacks
CD	—*1	○*2	○	○*2	○*4
Super Audio CD (2 channel)	Direct 2ch + SW	○*2 ○	○ ○	○*2 ○	× ×
Super Audio CD (Multi-channel)	—*1	○*3	○	○*3	×

*1 Not available for CDs or Super Audio CDs.

*2 Output through the Tri-Powered D/A Converter.

*3 The same signal that is output from the ANALOG 5.1CH OUT FRONT L/R jacks is output.

*4 Only when "D. OUTPUT" is set to "ON" (page 24).

Note

Tri-Powered D/A Converter System works only for 2 channel signals from 2 CH OUT jacks.

When the i.LINK indicator lights up

- No signal is output from all the other jacks (ANALOG 2CH OUT jacks, ANALOG 5.1CH OUT jacks, PHONES jack, DIGITAL (CD) OUT jacks).
- The Multi Channel Management function does not work.

💡 When you want to listen to the sound through headphones when the i.LINK indicator lights up

Connect the headphones to the PHONES jack on the amplifier, not on this player.

Location and Functions of Parts

This chapter tells you about the location and functions of the various buttons and controls on the front and rear panels and the supplied remote. Further details are provided on the pages indicated in parentheses. It also tells you about the information that appears in the display window.

Front Panel Parts Descriptions

- 1 POWER switch (16)**
Press to turn on the player.
- 2 TIME/TEXT button (17)**
Each time you press the button, the playing time of the track, the total remaining time on the disc, or TEXT information appears in the display.
- 3 SACD/CD button (16)**
Each time you press the button while playing back a hybrid disc, the layer to be played back switches between the HD (Super Audio CD) layer and the CD layer.
- 4 i.LINK button (16)**
Each time you press the button, the signal output switches between the i.LINK jack and the analog jacks.
i.LINK indicator (16)
Lights up when the i.LINK function is used.
- 5 Disc tra (16)**
Press \triangle OPEN/CLOSE to open/close the disc tray.

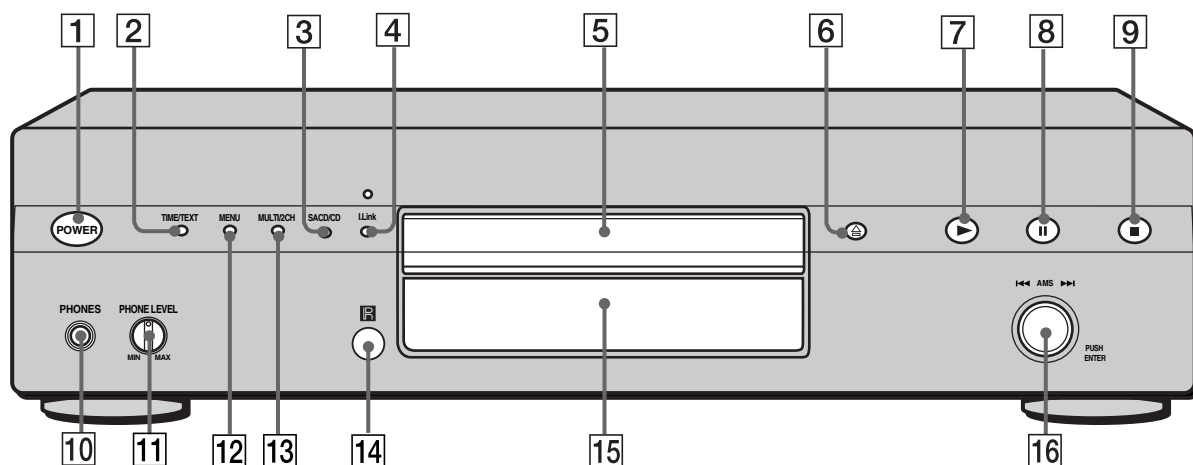

6  **OPEN/CLOSE button (16)**

Press to open or close the disc tray.

7  **▶ button (16)**

Press to start play.

8  **|| button (16)**

Press to pause play.

9  **■ button (16)**

Press to stop play.

10 **PHONES**

Connect the headphones.

During playback of a Multi-channel Super Audio CD, the same signal that is output from the ANALOG 5.1CH FRONT L/R jacks is output from the PHONES jack.

11 **PHONE LEVEL**

Adjust the headphones volume.

12 **MENU (15, 26 28)**

Press to enter the menu.

Press to exit from the menu and return to the normal display.



13 **MULTI/2CH button (16)**





Press to select the playback area when the 2 channel + Multi-channel Super Audio CD (page 15) is loaded.

14 **Remote sensor**

15 **Displa window (17)**

Shows various information.

16  **AMS**  **dial (AMS: Automatic Music Sensor) (20)**

When you turn the  AMS  dial counterclockwise by one click, you go back to the preceding track; when you turn the  AMS  dial clockwise by one click, you go to the succeeding track.

Rear Panel Parts Descriptions

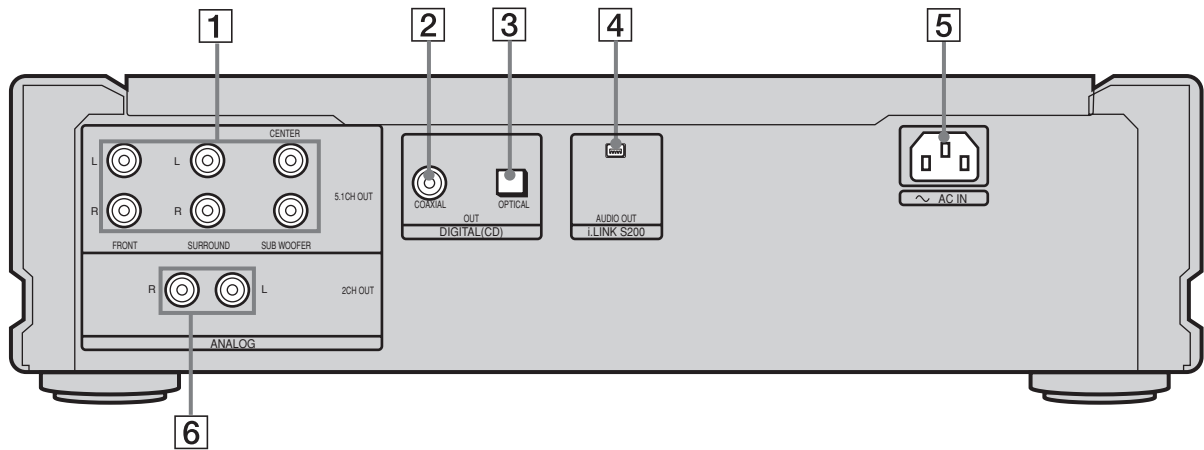

- 1 ANALOG 5.1CH OUT jacks (5)**
Connect to an amplifier equipped with the 5.1CH input jacks (Multi-channel amplifier, AV amplifier, etc.) using the audio connecting cords.
- 2 DIGITAL (CD) OUT COAXIAL connector (8)**
Connect to an audio component using the coaxial digital cable.
- 3 DIGITAL (CD) OUT OPTICAL connector (8)**
Connect to an audio component using an optical digital cable.
- 4 i.LINK S200 AUDIO OUT jack (7)**
Connect to STR-DA9000ES/TA-DA9000ES using the i.LINK connecting cord.
- 5 AC IN terminal (9)**
Connect the AC power cord.
- 6 ANALOG 2CH OUT L/R jacks (6)**
Connect to an audio component (stereo/2 channel) using the audio connecting cord.

Note

Only the audio signals of the CD can be output from the DIGITAL (CD) OUT connectors shown in 2 and 3. Those of the Super Audio CD cannot be output through DIGITAL (CD) OUT connectors.

When the i.LINK indicator lights up

No signal is output from all the other jacks (ANALOG 2CH OUT jacks, ANALOG 5.1CH OUT jacks, PHONES jack, DIGITAL (CD) OUT jacks).

Remote Parts Descriptions

- 1 CONTINUE button (22)**
Press to resume normal play from Shuffle Play or Program Play.
SHUFFLE button (22)
Press to select Shuffle Play.
PROGRAM button (23)
Press to select Program Play.
- 2 DISPLAY MODE button (18)**
Press to turn the display information off or on.
- 3 TIME/TEXT button (17)**
Each time you press the button, the playing time of the track, the total remaining time on the disc, or TEXT information appears in the display.
- 4 Number buttons (20)**
Press to enter the track numbers.
- 5 >10 button (20)**
Press to locate a track numbered over 10.
- 6 REPEAT button (21)**
Press repeatedly to play all tracks or only one track on the disc.
- 7 A↔B button (22)**
Press to select Repeat A-B Play.
- 8 ▷ button (16)**
Press to start play.
|| button (16)
Press to pause play.
■ button (16)
Press to stop play.
- 9 AMS ◀◀/▶▶ (AMS: Automatic Music Sensor) buttons (20)**
Press to locate a specific track.
- 10 ◀▶/▶▶ buttons (20)**
Press to locate a portion you want to play within a track.
- 11 INDEX ◀/▶ buttons (20)**
Press to locate a specific point marked with an index signal when you play a disc that has index signals.

- 12 SACD/CD button (16)**
Each time you press the button, "SACD" or "CD" appears in the display. Select the type of CD you want to play.
- 13 MULTI/2CH button (16)**
Press to select the playback area when the 2 channel + Multi-channel Super Audio CD (page 15) is loaded.
- 14 ENTER button (27)**
Press to decide the selection.
- 15 CLEAR button (23)**
Press to delete a programmed track number.
- 16 LEVEL ADJ button (27)**
Press to adjust the output level balance for the Multi-channel management function (page 25).
- 17 CHECK button (23)**
Press to check the programmed order.

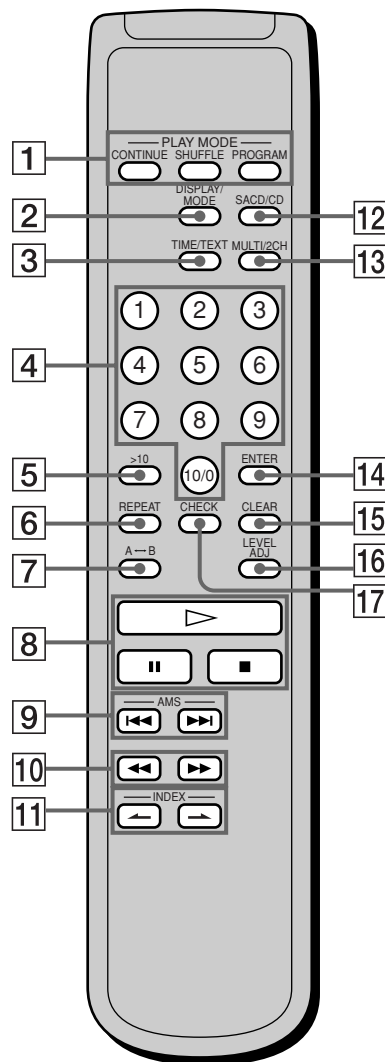

Compatible Disc Types

You can play the following discs with this player. Depending on the type of disc to be played, select the appropriate indicator by pressing SACD/CD or MULTI/2CH (page 16).

Classification by the layer configuration

Super Audio CD (single layer disc)

This disc consists of a single HD (high density) layer. When you play this disc, the player is set to the Super Audio CD playback mode automatically.

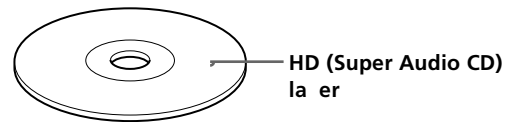

Super Audio CD (dual layer disc)

This disc consists of dual HD layers and is capable of extended play over long periods. When you play this disc, the player is set to the Super Audio CD playback mode automatically. Also, as the dual layer disc consists of dual HD layers on one side only, it is not necessary to turn the disc over.

HD (Super Audio CD) layer

HD (Super Audio CD) layer

Conventional CD

This disc is the standard format. When you play this disc, the player is set to the Conventional CD playback mode automatically.

CD layer

Super Audio CD + CD (Hybrid disc)

This disc consists of an HD layer and a CD layer. Press SACD/CD to select the layer you want to listen to. Also, as the dual layers are on one side, it is not necessary to turn the disc over. You can play the CD layer using a conventional CD player.

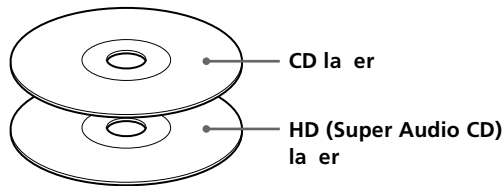

Selecting the default playback layer (HD or CD)

- 1 During stop mode, press MENU.
- 2 Turn **◀ AMS ▶** until **M/2CH SELECT** appears in the display.
- 3 Press **◀ AMS ▶**.
The current playback layer appears.
- 4 Turn **◀ AMS ▶** to select desired playback layer, then press **◀ AMS ▶**.

Classification by the channel configuration of the Super Audio CD

2 channel Super Audio CD

This disc consists of the 2 channel playback area. When you play this disc, the player is set to the 2 channel playback mode automatically.

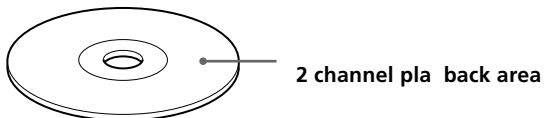

Multi-channel Super Audio CD

This disc consists of the multi-channel playback area. When you play this disc, the player is set to the multi-channel playback mode automatically.



2 channel + Multi-channel Super Audio CD

This disc consists of the 2 channel playback area and the multi-channel playback area. Press MULTI/2CH to select the playback area you want to listen to.

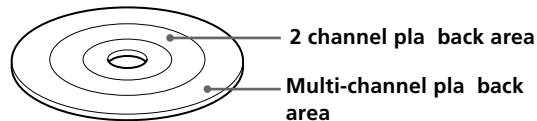

Selecting the default playback area (2 channel or multi-channel)

- 1 During stop mode, press MENU.
- 2 Turn **◀ AMS ▶** until **M/2CH SELECT** appears in the display.
- 3 Press **◀ AMS ▶**.
The current playback area appears.
- 4 Turn **◀ AMS ▶** to select desired playback area, then press **◀ AMS ▶**.

Incompatible Discs

This player cannot play the following discs. If you try to play them, the error message "TOC Error" or "No Disc" will appear or there will be no sound.

- CD-ROM
- DVD, etc.

Playing a Disc





The operations for normal play and the basic operations during play are explained below.

POWER SACD/CD  OPEN/CLOSE  

- 1** Turn on the amplifier. Turn down the volume level to the lowest.
- 2** Select the player position using the input selector on the amplifier.
- 3** Press POWER to turn on the player.
- 4** Press  OPEN/CLOSE to open the disc tray, and place a disc on the tray.



With the label side up

- 5** Press .
Playback starts from the first track. If you want to start playing from a specific track, turn    to select the track number before pressing .
- 6** Adjust the volume on the amplifier.

Using the Display

The display window shows various information about the disc or track being played. This section describes the current disc information and information that appears for each play status.

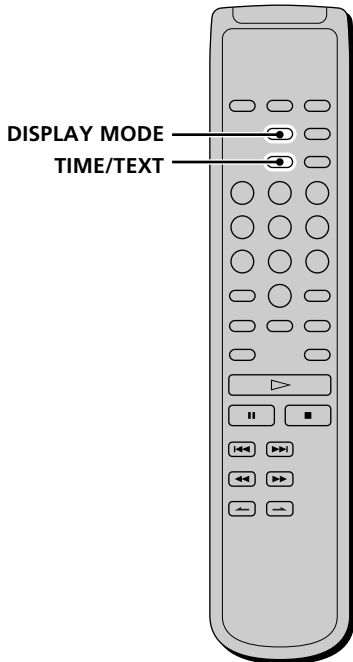
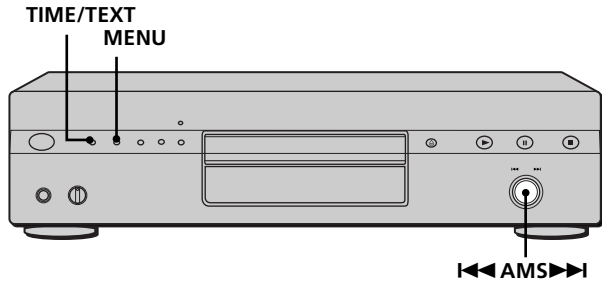

Disc information when a disc is loaded

Depending on the disc that is currently loaded, the display shows as follows:

2 channel Super Audio CD

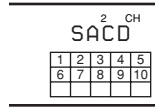

Multi-channel Super Audio CD

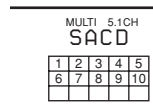

or

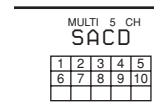

or

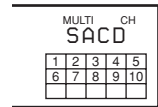

During playback of a 5.1 channel Super Audio CD

During playback of a 5 channel Super Audio CD

During playback of other Super Audio CDs or during stop mode

Conventional CD

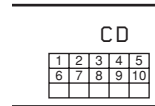

Displaying information while the player is stopped

Press TIME/TEXT.

The display shows the total number of tracks and total playing time.

Total number of tracks Total playing time



Using the Display

Displaying information while the player is playing

Press TIME/TEXT.

Each time you press the button, the current track number and its elapsed time or remaining time appears, or the total remaining time for the disc appears in the display. When the player detects a Multi-channel Super Audio CD, the channel information appears before the default display appears.

Playing track number and elapsed playing time of the current track (default display)



Press TIME/TEXT



Playing track number and remaining time of the current track



Press TIME/TEXT



Total remaining time on the disc



Press TIME/TEXT



Channel information (appears only when the player detects a Multi-channel Super Audio CD)

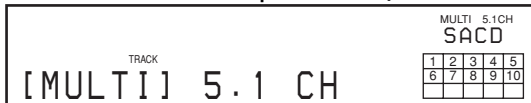

Turning off the information in the display



Each time you press DISPLAY MODE on the remote while playing a disc, the display turns off and on alternately. Even when the display is turned off, the display turns on if you pause or stop play. When you resume play, the display turns off again.

Before you start playing, when you press DISPLAY MODE to turn off the display, "Display Off" appears, and when you press the button to turn on the display, "Display On" appears.

Displaying the information of a TEXT disc

TEXT discs contain information, such as the disc name or artist name, as well as the audio signals. This player can display the disc name, artist name, and current track name as TEXT information.

When the player detects a TEXT disc, "TEXT" appears in the display. If your TEXT disc has several languages, "MULTI-TEXT" appears in the display. When you want to check the information in another language, see "Displaying the information of a TEXT disc in other languages" on page 19.

Displaying the information of a TEXT disc in stop mode

Press TIME/TEXT.

Each time you press the button, the disc name or artist name appears in the display. When you select the artist name, "ART." appears in the display.

• Before you start playing

Disc title



Press TIME/TEXT



Artist name



Press TIME/TEXT



Total number of tracks and total playing time



Press
TIME/
TEXT

Display information of a TEXT disc while playing a disc

The current track name appears. If the disc name has more than 15 characters, the first 14 characters will remain after the name scrolls by in the display.

When the player detects a Multi-channel Super Audio CD, the channel information appears before the playing time of the current track appears.

- While playing a disc

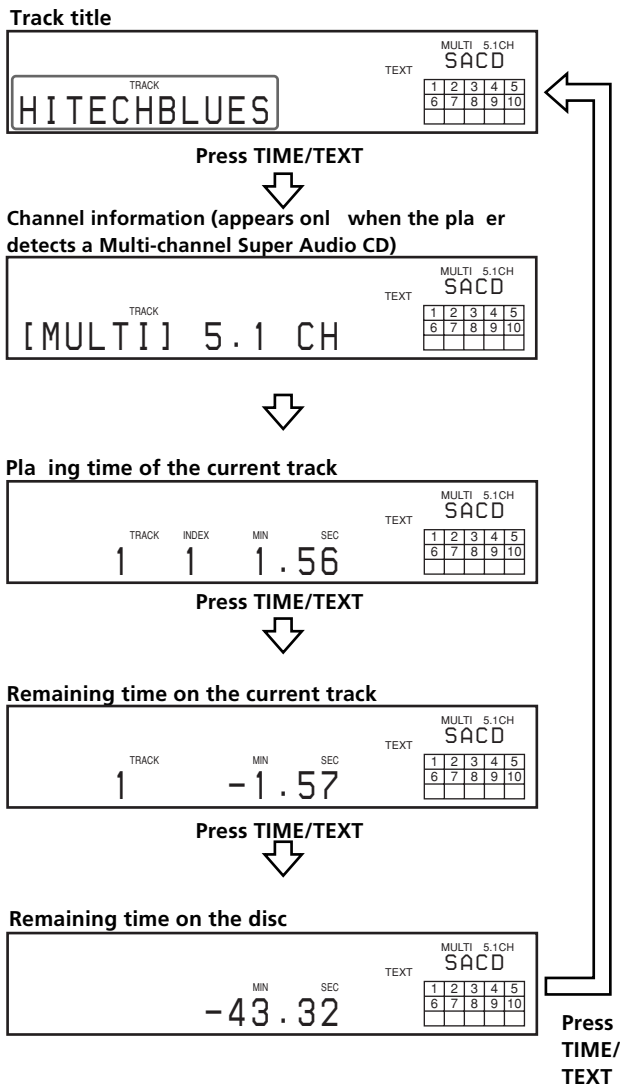

Notes

- The display may not show all the characters, depending on the disc.
- This player can display only the disc name, artist name, and track names from TEXT discs. Other information cannot be displayed.

Displaying the information of a TEXT disc in other languages

You can change the displayed language if the TEXT disc has multi language capacity. When the player detects such a TEXT disc, "MULTI-TEXT" appears in the display. Change the language according to the procedures below.

- 1 Press **MENU** in stop mode.
- 2 Turn **◀ AMS ▶** until **LANGUAGE** appears in the display.
- 3 Press **◀ AMS ▶**.
The current selected language (English, French, German, etc.) flashes.
If the player cannot display the language used in a TEXT disc, "Other lang" appears in the display.
- 4 Turn **◀ AMS ▶** until the desired language appears in the display.
- 5 Press **◀ AMS ▶**.
After a few seconds, the information appears in the selected language.

Locating a Specific Track

During stop or play mode, you can locate any track to be played.

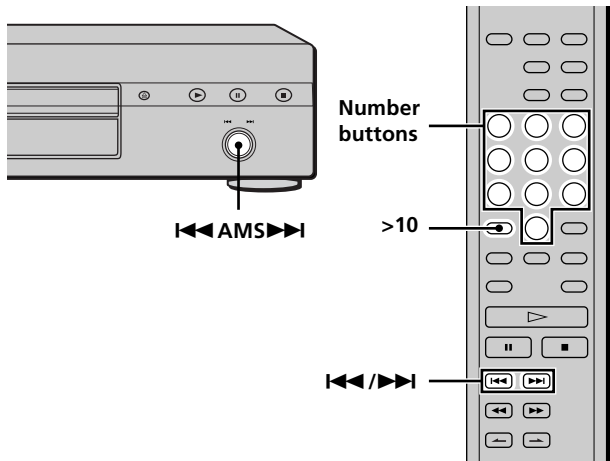

To locate	You need to
The next or succeeding tracks	Turn << AMS >> clockwise until you find the track. When using the remote, press >> repeatedly until you find the track.
The current or preceding tracks	Turn << AMS >> counterclockwise until you find the track. When using the remote, press << repeatedly until you find the track.
A specific track directly	Turn << AMS >> until you find the track number you want. When using the remote, press << or >> repeatedly until you find the track.

Locating a track directly by entering the track number

Press the number button(s) to enter the track number.

To enter a track number over 11

1 Press **>10**.

2 Enter the corresponding digits.

To enter 0, press 10/0 instead.

Examples:

- To play track number 30, press >10, then 3 and 10/0.
- To play track number 100, press >10 twice, then 1, and 10/0 twice.

Note

The default display reappears if you press >10 twice when the number of total tracks is less than 100.

Locating a Particular Point in a Track

You can locate a particular point in a track during play or play pause.

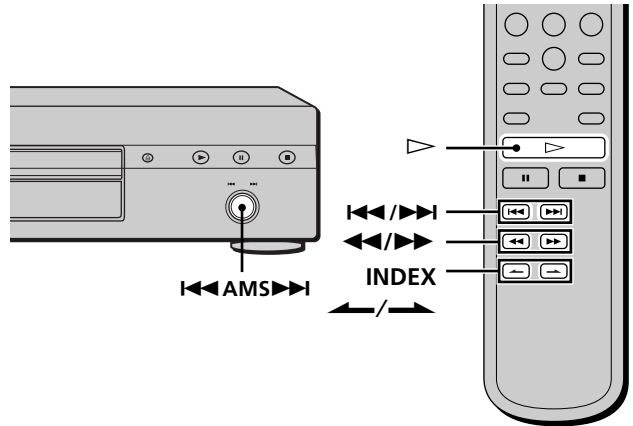

Locating a point while monitoring the sound (Search)

Press and hold **<</>>** during play .

You will hear intermittent playback as the disc goes forward or reverses.

When you reach the desired point, release the button.

Locating a point by observing the time indication (High-Speed Search)

Press and hold **<</>>** during play pause.

You will not hear the playback sound.

When "Over!!" appears in the display

The disc has reached its end. Press **<<** or **>>** to go back.

Note

Tracks that are only a few seconds long may be too short for monitoring. In this case, the player may not search correctly.

Locating a point using the index function (Index Search)

Press **INDEX→** or **INDEX←** repeatedly in play or pause mode.

What is an INDEX?

Some Super Audio CD or CD are provided with an index marking system which divides tracks or discs into smaller segments. This is especially useful when you want to locate a certain point within a long track (in classical music for example). The index search function works only when you use a commercially available indexed disc (usually indicated on the label).

Locating a point by setting the start time (Time Search)

- 1 Press **◀◀/▶▶** (or turn **◀◀ AMS ▶▶**) to select the desired track in stop mode.
- 2 Press and hold **◀◀/▶▶** to set the time to start play while looking at the display. You can set the time from the beginning of the desired track when you press **▶▶** at first, and set the time from the end of the desired track backward's when you press **◀◀** at first.



- 2 Press **▷**. Play will start at the time search.

Playing Tracks Repeatedly



You can play an entire disc or portions thereof repeatedly. This function can be used with Shuffle Play to repeat all the tracks in random order (page 22), or with Program Play to repeat all the tracks in a program (page 23). You can also repeat a specific track or portion within a track.

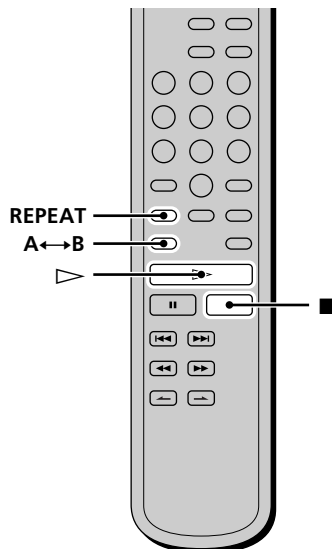

Note

If you turn off the player or disconnect the mains lead, the player will store the last setting of repeat play ("Repeat All" or "Repeat 1") and recall it the next time you turn on the player. However, the setting of the Repeat A-B Play will be cancelled if you turn off the player or disconnect the mains lead.

Repeating all the tracks on the disc (Repeat All Play)

Press **REPEAT** once, then press **▷**.

"Repeat" appears in the display and Repeat All Play starts.

The repeat play changes depending on the play mode you select.

When the play mode is	The player repeats
Normal play (page 16)	All the tracks in sequence
Shuffle Play (page 22)	All the tracks in random order
Program Play (page 23)	All the tracks in the program in sequence

To cancel Repeat All Play

Press **REPEAT** repeatedly until "REPEAT" goes off.

Playing Tracks Repeatedly

Repeating the current track (Repeat 1 Play)

While the track you want to repeat is being played, press REPEAT repeatedly until REPEAT 1 appears in the display.

Repeat 1 Play starts.

To cancel Repeat 1 Play

Press REPEAT repeatedly until "REPEAT 1" goes off.

Repeating a specific portion within a track (Repeat A-B Play)

You can specify one portion within a track to be played repeatedly. Note that the portion that you specify must be within the boundaries of a single track.

- 1 While the player is playing, press A↔B at the starting point (point A) of the portion to be played repeatedly.
"REPEAT" appears and "A" flashes in the display.
- 2 Continue playing the track (or press ►►) to locate the ending point (point B), then press A↔B.
"REPEAT A-B" appears and Repeat A-B Play starts.

To cancel Repeat A-B Play

Press REPEAT.

You can set a new starting point and ending point during Repeat A-B Play

You can change the current ending point to a new starting point, then specify a new ending point to repeat another portion right after the current portion.

- 1 During Repeat A-B Play, press A↔B.
The current ending point changes to the new starting point (point A).
"REPEAT" lights up and "A" flashes in the display.
- 2 Locate the new ending point (point B) and press A↔B.
"REPEAT A-B" lights up and the player starts to repeat the newly specified portion.

When you want to restart from the starting point A, press ► during A↔B repeat.

Playing Tracks in Random Order (Shuffle Play)

When you select Shuffle Play, the player plays all the tracks on the disc in random order.

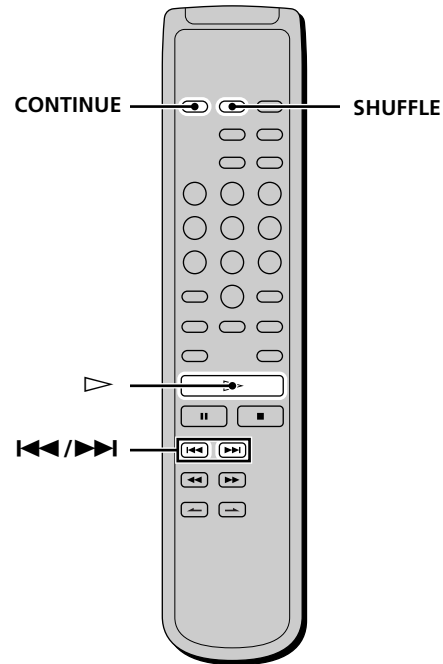

- 1 Press SHUFFLE in stop mode.

- 2 Press ►.

Shuffle Play starts.

"

" appears while the player is "shuffling" the tracks. The player will stop after playing all the tracks once.

To resume normal play

Press CONTINUE.

You can locate tracks during Shuffle Play

Press ◀◀/▶▶.

Press ▶▶ to locate the next track or press ◀◀ to locate the beginning of the current track. The player does not go back to tracks which have already been played.

Note

When you change the playback area (2 channel/multi channel) or layer (CD/HD) of the Super Audio CD (page 15), Shuffle Play setting is cleared.

Creating Your Own Program (Program Play)

You can pick out the tracks that you like and specify the playback order in a program containing up to 32 tracks (or 999 min. 59 sec. in total program time)

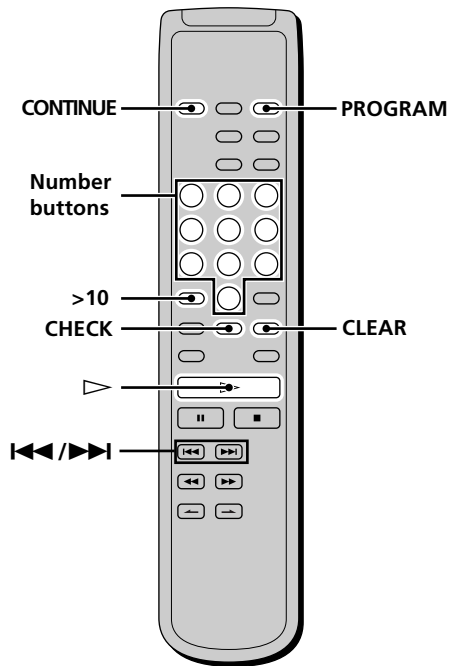



- 1 Press PROGRAM in stop mode.**
"Program" appears in the display.
- 2 Press the number buttons to enter the track number.**

If you entered the wrong track number
Press CLEAR to erase the track number and reenter the correct track number using the number buttons.

To select a track number over 11
Press >10 (page 20).
- 3 Repeat step 2 to enter other tracks.**
Each time you enter a track number, the total program time appears in the display.
- 4 Press ▷.**
Program Play starts.

To resume normal play
Press CONTINUE.

 **The program remains even after Program Play ends**
Press ▷ to play from the beginning of the program again.
The program remains even if you stop play.

Note
If you turn off the player, disconnect the mains lead, press  OPEN/CLOSE, or change the playback area (2 channel/mulch channel) or layer (CD/HD) of the Super Audio CD (page 15), the program will be erased.



Checking the contents of the program

Before you start playing or while the player is playing, press CHECK.

Each time you press the button, the track numbers will appear in the display in the programmed order.
When you press CHECK while the player is playing, the track number appears from the next track numbers of the current playing track number.

Changing the contents of the program

You can change the contents of the program in stop mode.

To	Do the following:
Erase a track	<ol style="list-style-type: none"> 1 Press CHECK repeatedly until the track number you want to erase appears. 2 Press CLEAR.
Erase from the last track in the program	<p>Press CLEAR.</p> <p>Each time you press the button, the last track of the program is erased.</p>
Add a track to the end of the program	<p>Press  to select the track you want to add, then press PROGRAM. When using the remote, press the number button of the track to be added.</p>
Erase all tracks	<p>Hold down CLEAR or  (for about 2 seconds) until "Prog CLEAR" appears in the display.</p>

Listening to a CD Using a Filter (Digital Filter Function)

This player is equipped with a digital filter that eliminates noise generated during sampling. By selecting type of filters, you can adjust the sound quality.

You can select "STANDARD" or "OPTION." (The default setting is "STANDARD.")

When the i.LINK indicator is lit

This function is not available.

◀◀ AMS ▶▶



- 1 Press MENU.
- 2 Turn ◀◀ AMS ▶▶ until / D. FILTER appears in the display .
- 3 Press ◀◀ AMS ▶▶.
- 4 Turn ◀◀ AMS ▶▶ until desired filter name (/ STANDARD or / OPTION) appears in the display .
- 5 Press ◀◀ AMS ▶▶.
When you select "OPTION," "FILTER" appears in the display.

Characteristics of each digital filter

STANDARD

Provides a wide frequency range and spatial feeling.

OPTION

Provides smooth and powerful sound with clear image position.

Notes

- Digital filters are effective only when you play a conventional CD. You cannot select the digital filter when you play a Super Audio CD.
- According to the disc or connected equipment, there may be no noticeable effect after switching the filter.

Listening to a Multi-channel Super Audio CD

(Multi-channel management function)

This player is equipped with a Multi-channel management function that sets the playback mode of the Super Audio CD by the DSD-DSP (built into the player) according to the layout or size of your speaker.

When the i.LINK indicator is lit
This function is not available.

Example of the speaker layout

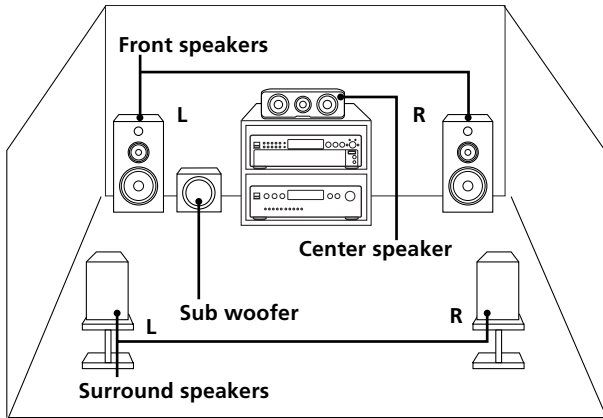

To set the Multi-channel management:

- 1 Select the appropriate preset playback mode (2 channel playback or Multi-channel playback).
- 2 Adjust the output level balance of each speaker (only when you select the Multi-channel playback mode).

Notes

- This features only work when you play a Super Audio CD.
- You may not be able to adjust the output level balance depending on the speaker layout mode that you selected.

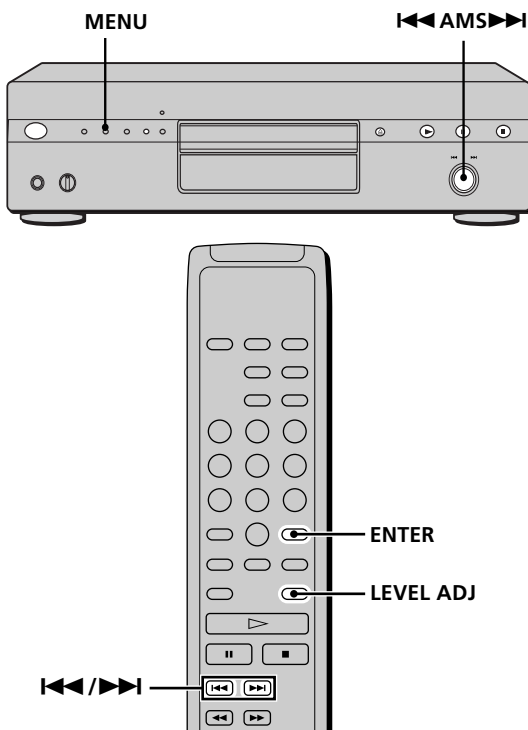

Selecting 2 channel playback mode

- 1 Press MENU.
- 2 Turn **◀ AMS ▶** until '2CH SPK MODE' appears in the display.
- 3 Press **◀ AMS ▶**.
The playback mode appears in the display.

Playback mode	Front speakers	Sub woofer
2CH Direct	Each signal outputs directly from front speakers. No signal outputs from the Sub woofer.	
2CH + SW	○	○

- 4 Turn **◀ AMS ▶** until desired mode appears in the display.
- 5 Press **◀ AMS ▶**.

Note

You cannot operate this function when the player is in the CD or Multi-channel playback mode. Operate this function when the player is in the 2 channel Super Audio CD playback mode, the disc tray is opened, or no discs are in the player.

Selecting Multi-channel playback mode

- 1 Press MENU.
- 2 Turn **◀ AMS ▶** until 'MCH SPK MODE' appears in the display.
- 3 Press **◀ AMS ▶**.
The playback mode appears in the display.

Playback mode	Front speakers	Center speaker	Surround speakers	Sub woofer
MCH Direct	Each signal outputs directly from each speaker.			
5 - Large + SW	Large	Large	Large	○
5 - Large	Large	Large	Large	--
5 - Small + SW	Small	Small	Small	○
FRT - Large +SW	Large	Small	Small	○
FRT - Large	Large	Small	Small	--
No - CNTR + SW	Large	--	Large	○
No - CNTR	Large	--	Large	--

About / Large or / Small speaker

A “Large” speaker is a speaker that can reproduce bass frequencies plentifully. If you select “Small” for the surround speakers, the bass frequencies will come from the front speakers and/or sub woofer.

For normal use, select “MCH Direct” or set all the speakers to “Large” (ex. “5 – Large + SW,” “5 – Large,” etc.). If the sound is noisy or the Multi-channel playback is not effective while playing a Multi-channel Super Audio CD, change the settings of the speakers concerned to “Small.”

4 Turn **I◀◀ AMS ▶▶I** until desired mode appears in the displa .

5 Press **I◀◀ AMS ▶▶I**.

To return to the normal display, press MENU.

Notes

- The Multi-channel management function does not work when you select “MCH Direct” (you cannot set the output level balance of each speaker).
- The front speaker setting is set to “Large” automatically when you set the Sub woofer to “--.”
- When you play a track that does not contain the LFE* signal, the signal for the Sub woofer does not output. Therefore, when you select “MCH Direct,” “5 – Large + SW,” or “No – CNTR + SW,” no signal outputs from the Sub woofer. However, when you select “5 – Small + SW” or “FRT – Large +SW” (when you set the speaker setting to “Small”), the bass frequencies will come from the sub woofer.

* Low Frequency Enhancement (described as “.1 CH”)

Adjusting the output level balance of each speaker

You can adjust following items with the Multi-channel management function:

CNTR BALANCE

The relative output level balance between the front speakers (FRONT L/R) and the center speaker (CENTER)

SURR BALANCE

The relative output level balance between the front speakers (FRONT L/R) and the surround speakers (SURR L/R)

SW BALANCE

The relative output level balance between the front speakers (FRONT L/R) and the sub woofer (SUB WOOFER)

Note

Some adjustment may not work depending on the Multi-channel playback mode that you selected.

Adjusting the output level balance on the front panel of the player

You can adjust the output level balance of each speaker while listening during playback. You can also adjust while listening to the test tone during stop mode.

1 Press MENU.

2 Turn **I◀◀ AMS ▶▶I** until / LEVEL ADJUST appears in the displa .

3 Press **I◀◀ AMS ▶▶I**.

During playback, go to Step 6.

4 Turn **I◀◀ AMS ▶▶I** until / TONE ON appears in the displa .

5 Press **I◀◀ AMS ▶▶I**.

The test tone issues from the speakers in sequence with the speaker type appearing in the display.

6 Turn **I◀◀ AMS ▶▶I** until the desired item appears in the displa .

Select the item from “CNTR BALANCE,” “SURR BALANCE,” or “SW BALANCE.”

Note

When you set the Sub woofer to “--” in the Multi-channel playback mode (page 25), “SW BALANCE” does not appear. Similarly, “CNTR BALANCE” or “SURR BALANCE” does not appear when you set the corresponding speaker to “--.”

7 Press ◀◀ AMS ▶▶.

The balance adjustment display appears. In stop mode, the test tone is output from the selected speaker.
 Example: When you select “SURR BALANCE” during stop mode, the test tone is output from the front speakers and surround speakers.



8 Turn ◀◀ AMS ▶▶ to adjust the output level.



9 Press ◀◀ AMS ▶▶.

The player status returns to Step 6. Repeat Step 6 through 9 for more adjustments.

10 Press MENU after ou finish adjusting.

The display returns to the normal display.

Adjusting the output level from the remote

You can adjust the output level of each speaker from the listening position by using the supplied remote.

1 Press LEVEL ADJ during playback or stop mode.

During playback, go to Step 4.

2 Press ◀◀/▶▶ repeatedly until TONE ON appears in the display.

3 Press ENTER.

The test tone issues from the speakers in sequence with the speaker type appearing in the display.

4 Press ◀◀/▶▶ repeatedly until the desired item appears in the display.

Select the item from “CNTR BALANCE,” “SURR BALANCE,” or “SW BALANCE.”

Note

When you set the Sub woofer to “--” in the Multi-channel playback mode (page 25), “SW BALANCE” does not appear. Similarly, “CNTR BALANCE” or “SURR BALANCE” does not appear when you set the corresponding speaker to “--.”

5 Press ENTER.

The balance adjustment display appears. In stop mode, the test tone is output from the selected speaker.
 Example: When you select “SURR BALANCE” during stop mode, the test tone is output from the front speakers and surround speakers.



6 Press ◀◀/▶▶ repeatedly to adjust the output level.

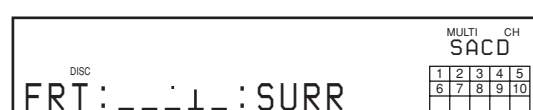

7 Press ENTER.

The player status returns to Step 4. Repeat Step 4 through 7 for more adjustments.

8 Press LEVEL ADJ after ou finish adjusting.

The display returns to the normal display.

Note

If you select a playback mode other than “2CH Direct” or “MCH Direct” using the Multi-channel management function, the sound distribution to the speakers will change, possibly causing a decrease in overall sound volume. If this occurs, adjust the volume with the volume control on the connected amplifier.

Adjusting the speaker distance

You can adjust the speaker distance when the connected amplifier does not have the setting menu for speaker distance. If the amplifier has this function, we recommend that you set the speaker distance on the amplifier. This setting is available only for the Multi-Channel Super Audio CD.

Note

When you set the speaker distance on this player and the amplifier, both of the setting may work and you may not be able to get the proper result.

FRT DIST.

The distance from your listening position to the front speakers

You can adjust from 1.0 meter to 7.0 meters (3 to 23 feet) in 0.1 meter (1 foot) steps.

If both front speakers are not placed an equal distance from your listening position, set the distance to the closest speaker.

SURR DIST.

The distance from your listening position to the surround speakers

You can adjust from 1.0 meter to 7.0 meters (3 to 23 feet) in 0.1 meter (1 foot) steps.

If both front speakers are not placed an equal distance from your listening position, set the distance to the closest speaker.

CNTR DIST.

The distance from your listening position to the center speaker

You can adjust from 1.0 meter to 7.0 meters (3 to 23 feet) in 0.1 meter (1 foot) steps.

SUBW DIST.

The distance from your listening position to the sub woofer

You can adjust from 1.0 meter to 7.0 meters (3 to 23 feet) in 0.1 meter (1 foot) steps.

DIST. UNIT

The unit of measure for setting distances (meter or feet)
The initial setting is “feet” for the North American model and “meter” for the European model.

Note

Speaker distance cannot be adjusted in the following cases.

- When the player is reading the disc information of CD (or the CD area of Super Audio CD)
- When the player is reading the 2 channel area of Super Audio CD
- When the i.LINK indicator is lit

- 1 Press MENU.
- 2 Turn **◀◀ AMS ▶▶** until **SPK DISTANCE** appears in the display.
- 3 Press **◀◀ AMS ▶▶**.
- 4 Turn **◀◀ AMS ▶▶** until the desired item appears in the display.
Select the item from “FRT DIST.,” “SURR DIST.,” “CNTR DIST.,” or “SUBW DIST.”

Note

When you set the Sub woofer to “--” in the Multi-channel playback mode (page 25), “SUBW DIST” cannot be adjusted (“Not In Use” appears). Similarly, “CNTR DIST.” cannot be adjusted (“Not In Use” appears) when you set the corresponding speaker to “--.”

- 5 Press **◀◀ AMS ▶▶**.
The speaker distance adjustment display appears.
Example: When you select “SURR DIST” (with “DIST. UNIT” set to “meter”).



- 6 Turn **◀◀ AMS ▶▶** to adjust the speaker distance.



- 7 Press **◀◀ AMS ▶▶**.
The player status returns to Step 4.
Repeat Step 4 through 7 for more adjustments.
- 8 Press MENU after you finish adjusting.
The display returns to the normal display.

Selecting the distance unit

In Step 4 above, select “DIST. UNIT”.
Turn **◀◀ AMS ▶▶** to select “meter” or “feet”, then press **◀◀ AMS ▶▶**.

Setting speaker distances back to the default

Set all speaker distances to 3 meters (10 feet).

Additional Information

This chapter provides additional information that will help you understand and maintain your Super Audio CD player.

Precautions

On safety

- Caution — The use of optical instruments with this product will increase eye hazard.
- Should any solid object or liquid fall into the cabinet, unplug the player and have it checked by qualified personnel before operating it any further.
- AC power cord must be changed only at the qualified service shop.
- The unit is not disconnected from the AC power source (mains) as long as it is connected to the wall outlet, even if the unit itself has been turned off.

On power sources

- Before operating the player, check that the operating voltage of the player is identical with your local power supply. The operating voltage is indicated on the nameplate at the rear of the player.
- The player is not disconnected from the mains as long as it is attached to the mains, even if the player itself has been turned off.
- If you are not going to use the player for a long time, be sure to disconnect the player from the mains. To disconnect the mains lead, grasp the plug itself; never pull the cord.

On placement

- Place the player in a location with adequate ventilation to prevent heat build-up in the player.
- Do not place the player on a soft surface such as a rug that might block the ventilation holes on the bottom.
- Do not place the player in a location near heat sources, or in a place subject to direct sunlight, excessive dust or mechanical shock.

On operation

- If the player is brought directly from a cold to a warm location, or is placed in a very damp room, moisture may condense on the lenses inside the player. Should this occur, the player may not operate properly. In this case, remove the disc and leave the player turned on for about an hour until the moisture evaporates.
- During power on, some noise may be heard while the disc is being loaded into the Super Audio CD player. This is not a malfunction.

On adjusting the volume

- Do not turn up the volume too much while listening to a portion with very low level inputs or no audio signals. If you do, the speakers may be damaged when a peak level portion is played.

Precautions

On inserting a disc

- You may hear a transmission or a mechanical sound from the player. This indicates that the player is automatically adjusting its internal mechanisms according to the inserted disc. You may also hear the mechanical sound from the player when you insert a warped disc.

On cleaning

- Clean the cabinet, panel, and controls with a soft cloth slightly moistened with a mild detergent solution. Do not use any type of abrasive pad, scouring powder, or solvent such as alcohol or benzine.

On transportation

- Be sure to remove the disc on the tray.
- Be sure to close the disc tray.

If you have any questions or problems concerning your player, please consult your nearest Sony dealer.

Notes on Discs

On handling discs

- To keep the disc clean, handle the disc by its edge. Do not touch the surface.
- Do not stick paper or tape on the disc.

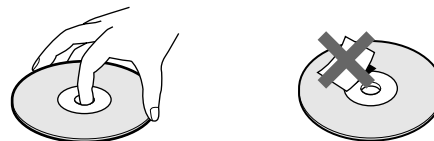

- Use only round-shaped discs. If you use a special shaped disc (e.g., star-shaped, heart-shaped, or square-shaped, etc.), the player may be damaged.
- Do not use a disc with a seal attached on such as on a used disc or rental disc.

On keeping discs

- Do not expose the disc to direct sunlight or heat sources such as hot air ducts.
- After playing, store the disc in its case. If you put it on top of another disc without the case, the disc may be damaged.

On placing discs on the disc tray

- Make sure the disc is positioned securely on the tray. If not, the player or the disc may be damaged.

On cleaning

- If the disc is dirty with fingerprints or dust, it may lessen the quality of the audio out.
- Before playing, clean the disc with a cleaning cloth. Wipe the disc from the centre out.

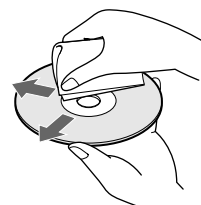

- Clean the disc with a soft cloth slightly moistened with water, and remove moisture with a dry cloth.
- Do not use solvents such as benzine, thinner, record cleaners, or anti-static spray.

Notes on CD-R/CD-RW playback

- Discs recorded on CD-R/CD-RW drives may not be played back because of scratches, dirt, recording condition, or the drive's characteristics. Besides, the discs, which are not yet finalized at the end of recording, cannot be played back.

Music discs encoded with copyright protection technologies

This product is designed to playback discs that conform to the Compact Disc (CD) standard.

Recently, various music discs encoded with copyright protection technologies are marketed by some record companies. Please be aware that among those discs, there are some that do not conform to the CD standard and may not be playable by this product.

Troubleshooting

If you experience any of the following difficulties while using the player, use this troubleshooting guide to help you remedy the problem. Should any problem persist, consult your nearest Sony dealer.

There is no sound from the i.LINK S200 AUDIO OUT jack.

Is the i.LINK component selected by the input selector on the connected amplifier?

- ➔ Make sure the i.LINK component is selected by the input selector on the connected amplifier. Refer to the Operating Instructions supplied with the amplifier.

Is the i.LINK function turned on?

- ➔ See page 16. Press i.LINK to output signals from the i.LINK S200 AUDIO OUT jack. When the i.LINK function is on, i.LINK indicator lights up.

Is the i.LINK cord connected correctly?

- ➔ Check the connection and connect the cord firmly.

Is the correct i.LINK cord used?

- ➔ Make sure you use the i.LINK cord compatible with i.LINK S200 (less than 3.5 meters).

Is the connection to the i.LINK component verified?

- ➔ See page 7. Refer to the Operating Instructions supplied with the component.

Are several i.LINK components connected?

- ➔ There may be no sound when several i.LINK components are connected.

There is no sound when beginning the playback.

- ➔ According to the copy protection technology, no sound is output while components are establishing LINC.

There is no sound from the ANALOG OUT jacks.

Is the i.LINK function turned on?

- ➔ When the i.LINK function is on, no sound is output from the ANALOG OUT jacks. Press i.LINK to turn off the i.LINK indicator.

Is the input selector on the amplifier correctly set?

- ➔ Set the input selector on the amplifier correctly to output the sound from this player.
- ➔ Make sure this player is connected to the correct input jacks on the amplifier.

Is the connecting cord connected correctly?

- ➔ Check the connection and connect the cord firmly.

There is no sound from the DIGITAL (CD) OUT connectors.

Is the i.LINK function turned on?

- ➔ When the i.LINK function is on, no sound is output from the DIGITAL (CD) OUT jacks. Press i.LINK to turn off the i.LINK indicator.

Is a Super Audio CD played back?

- ➔ The audio signals of the Super Audio CD cannot be output from the DIGITAL (CD) OUT connectors.

Is "D. OUTPUT" in the menu set to "Off"?

- ➔ Set "D. OUTPUT" to "On" (see page 24).

There is no sound from the SUB WOOFER jack.

- ➔ Select the playback mode so that the Sub woofer is set to "O" (see page 25).

- ➔ When you play a track that does not contain the LFE signal, the signal outputs from the SUB WOOFER jack only when you select "5 - Small + SW" or "FRT - Large + SW" for the Multi-channel playback mode (see page 24).

There is no sound from the headphones.

Is the i.LINK function turned on?

- ➔ When the i.LINK function is on, no sound is output from the PHONES jack. Use the headphones output on your amplifier.

The disc does not play.

Is a correct disc inserted?

- ➔ Make sure there is a disc inside the player.
- ➔ Make sure the disc is not placed upside down on the tray. Place the disc on the disc tray with the label side up.
- ➔ If the disc is placed at an angle, reload the disc.
- ➔ If the disc is dirty, clean the disc (see page 30).
- ➔ Make sure the disc is compatible with this player (see page 15).

Moisture has condensed inside the player.

- ➔ Remove the disc and leave the player turned on for about an hour.

The remote does not function.

Are there any obstacles in the path of the remote and the player?

- ➔ Use the remote from the location you can see this player.

The remote is not pointed at the remote sensor on the player.

- ➔ Point the remote at the remote sensor on the player.

Are the batteries in the remote weak?

- ➔ Replace with new batteries.

Display Messages

The following table explains the various messages that appear in the display.

Message	Error code(s)	Cause and/or remedy
TOC ERROR	—	An incompatible disc is inserted.
BUS FULL	C78:15	The signal bus within the i.LINK configuration is full and no more signals can be output from the player. Cancel the LINC between the component and this player.

Specifications

When a super audio CD is played

Playing frequency range	2 Hz to 100 kHz
Frequency response	2 Hz to 50 kHz (-3 dB)
Dynamic range	108 dB or more
Total harmonic distortion rate	0.0012 % or less
Wow and flutter	Value of measurable limit (± 0.001 % W. PEAK) or less

When a CD is played

Frequency response	2 Hz to 20 kHz
Dynamic range	100 dB or more
Total harmonic distortion rate	0.0017 % or less
Wow and flutter	Value of measurable limit (± 0.001 % W. PEAK) or less

Output connector

	Jack type	Output level	Load impedance
ANALOG OUT	Phono jacks	2 Vrms (at 50 kilohms)	Over 10 kilohms
DIGITAL (CD) OUT OPTICAL*	Square optical output connector	-18 dBm	(Light emitting wave length: 660 nm)
DIGITAL (CD) OUT COAXIAL*	Coaxial output connector	0.5 Vp-p	75 ohms
PHONES	Stereo phone jack	10 mW	32 ohms

*Output only the audio signals of the CD

i.LINK section

Pin	4 pins
Transmission speed	S200 (Maximum data transmission speed 200 Mbps)
Transmission protocol	A/M transmission protocol
Format (output)	Super Audio CD* (DSD PLAIN) 2 channel linear PCM (IEC 60958-3) Sampling frequency: 44.1 kHz

* Conforms to the copy protection technology of DTLA (Revision 1.2).

General

Laser Semiconductor laser
(SACD: $\lambda = 650$ nm)
(CD: $\lambda = 780$ nm)
Emission duration: continuous

Laser radiant power: 5.47 μ W at 650 nm

*These output is the value measured at a distance of about 200mm from the objective lens surface on the optical pick-up.

Power requirements 120 V AC, 60 Hz

Power consumption 32 W

Dimensions (w/h/d) 430 \times 130 \times 380 mm
(17 \times 5 1/8 \times 15 in.)
incl. projecting parts

Mass (approx.) 16 kg (35 lbs 5 oz.)

Supplied accessories

See page 4.

Design and specifications are subject to change without notice.

Index

A

- Accessories 4
- Amplifier (not supplied) 5
- AMS (Automatic Music Sensor) 20
- ANALOG OUT
 - 2CH 6
 - 5.1CH 5
- Area 15

B

- Batteries 4

C

- Cable
 - Coaxial digital 8
 - Optical digital 8
- Cord
 - Audio connecting 5
 - i.LINK connecting 7

D, E, F, G

- DIGITAL (CD) OUT 8
- Digital filter 24
- Displaying information 17

H

- Hooking Up
 - Audio Components 5
 - Power 7

I, J, K

- i.LINK 7, 16

L

- Layer 14
- Locating
 - a specific track 20
 - a particular point 20
 - by entering the track number 20
 - by observing the time indication (High-speed Search) 20
 - using the index function (Index Search) 20
 - while monitoring the sound (Search) 20

M, N

- Multi-channel management function 25
- Multi-channel Super Audio CD 15

O

- Output level balance 26

P, Q

- Pause play 16
- Place a disc 16
- Playback mode
 - 2 channel 25
 - Multi-channel 25
- Playing
 - a disc 16
 - by entering the track number 20
 - Multi-channel Super Audio CD 25
 - repeatedly 21
 - track in random order 22
- Plug adapter 9
- Program Play
 - Checking the contents of the program 23
 - Changing the contents of the program 23
 - how to create your own program 23

R

- Remote commander (remote) 13
- Repeat
 - A-B Play 22
 - All Play 21
 - 1 Play 22

S

- Search
 - High-speed search 20
 - Index search 20
 - Time Search 21
- Shuffle Play 22
- Speaker distance 28
- Super Audio CD 14

T, U, V, W, X, Y, Z

- TEXT 18
- TOC 15