

**namco®**

**Update 1**

**AQUA JET**

**ROSTA SPRING SHAFT ASSEMBLY**

**REPLACEMENT INSTRUCTIONS**

## SAFETY WARNINGS

Ensure that the machine is switched OFF and disconnected from the mains supply before commencing any work.

To maintain safety and minimise the risk of injury to personnel or damage to the machine follow the Instructions for Replacement precisely

Some of the parts to be removed are heavy. Ensure that at least two people are available to remove these items.

The air line connectors design is such that the more the tube is pulled, the tighter the connection becomes, so it is imperative that the blue locking ring is pushed towards the connector when removing the air tubes.

The compressor used in this machine has a reservoir tank and a loud hissing noise will be heard as the air is released when the first air tube is disconnected.

Take care not to squash or bend any of the air tubes during disassembly or reassembly.

If there are any doubts or queries please telephone Technical Service on 0181-324-6120 for advice before continuing.

### TOOLS and PARTS REQUIRED

Ratchet Handle

Ratchet Handle Extension Bar

Hex Sockets ..... 10mm  
13mm  
17mm  
 $\frac{9}{16}$  " AF

Spanner ..... 13mm

Pozi Driver ..... No.2

Hex Wrench ..... 8mm

Security Wrench for M5 Security Button Head Screws

Rosta Spring Shaft Assembly ..... Part No 46000088A (Supplied)

10ml Loctite 242..... Part No 95000004 (Supplied)

Castrol LM Grease ..... Part No - - - - - (Supplied)

1. Remove 4 off Hex Head Screws (M8x60). Raise the level adjusters on the Ride Assembly and separate the ride assembly from the monitor cabinet only sufficiently enough to disconnect the connectors and air line.

*Note: Ensure that the blue locking ring is pushed towards the connector when removing the air tube. There may be a loud "hissing" noise as the air in the compressor tank is released,*

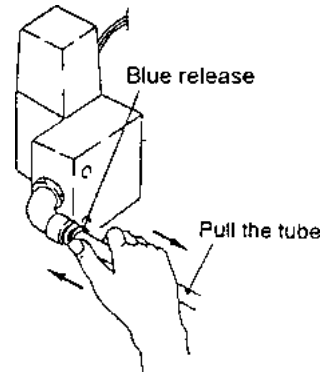

2. Move the ride assembly away from the monitor cabinet to give sufficient room to work and lower the level adjusters to keep the ride assembly stationary whilst working.

3. Remove 8 off Security Screws (M5x30), 4ea side, and remove the rubber skirts, complete with fixing brackets and lay on the Main Base Assy.

*Note: Take care not to bend or distort the long fixing brackets.*

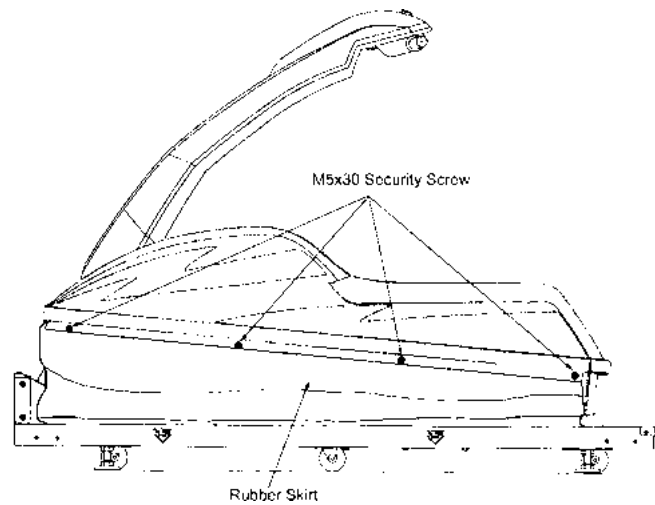

4. Remove 8 off Security screws (M5x16), 4ea side, and remove the Vac-Form Closing Bracket.

5. Remove 4 off Security Screw (M5x16) and 4 off Security Screw (M5x20) and remove the Tank Vac-Form.

*Note: Lift the Vac-Form and turn it through 90° to remove it from the Control Arm assembly.*

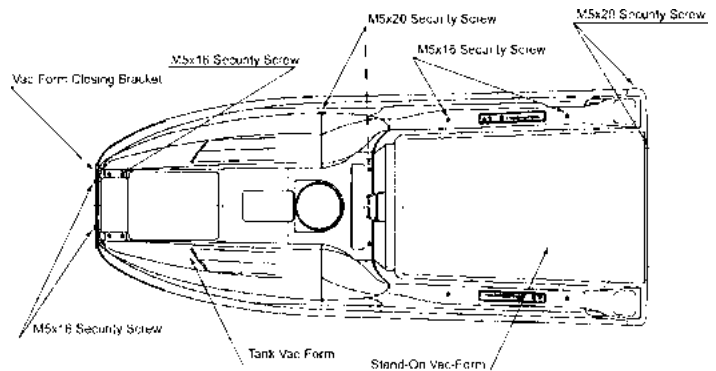

6. Remove 4 off Security Screw (M5x16) and 4 off Security Screw (M5x20) and remove the Stand-On Vac-Form.

7. Remove 6 off Security Screw (M5x16), 3 screws each side, and remove the Side Vac-Forms.

8. Remove 2 off Security Screw (M5x16) and remove the Rear Vac-Form.

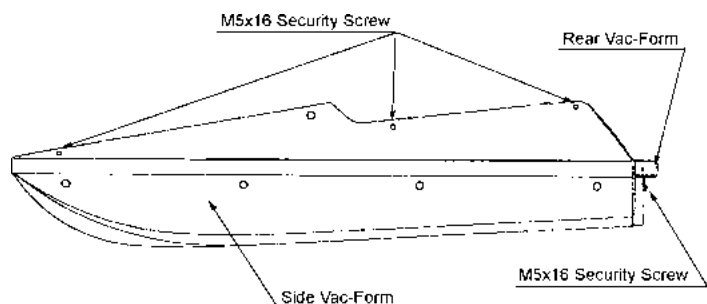

9. Disconnect the 3way and 9way connectors located at the base of the control arm on the right hand side.

10. Remove 8off Hex Head Screws (M8x45) and remove the control arm assembly. The 13mm spanner will be required to remove the two front screws as there is insufficient room to use a socket.

*Note: This assembly is heavy, ensure that at least two people are available to remove this unit.*

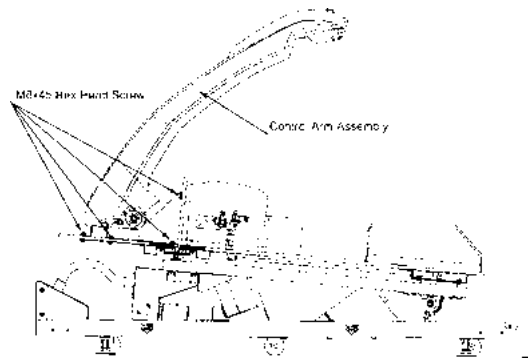

11. Disconnect the 15way connector and remove the Pozi Head Screw (M4x12) retaining the Earth wire inside the Tank Speaker Box.

12. Disconnect the Air Tubes from the connectors A and B and disconnect the two 2way connectors from the Air Valves

*Note: Ensure that the Blue Locking Ring is pushed towards the connector when removing the air tube*

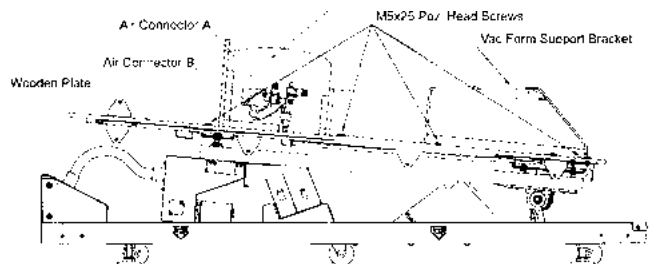

13. Remove 4off Pozi Head Screws (M5x25) and remove the Vac-Form Support Brackets.

14. Remove 6off Pozi Head Screws (M5x25) and remove the Wooden Plate.

15. Remove 2off Hex Head Screws ( $\frac{3}{8} \times \frac{3}{4}$  AF) from the top of the Air Spring.

16. Remove 8off Hex Head Screws (M8x25) and remove the Stand-On Metal Plate.

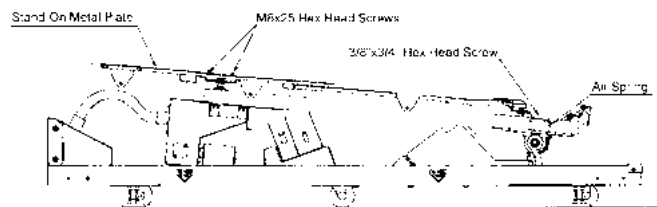

17. Remove 8off Hex Head Screws (M10x25) retaining the Ride Base to the bearings.

18. Remove 4off Hex Head Screws (M10x25) retaining the Ride Base to the Joint Box, on the underside.

19. Remove the Ride Base Assembly.  
*Note: This item is heavy. Ensure that two people are available to remove this item.*

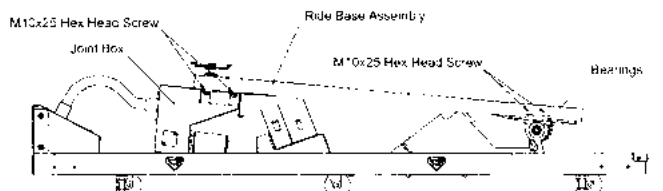

20. Remove 7off Hex Head Screws (M8x25) and remove the Rosta Spring Shaft Assembly from the Main Base.

*Note: This item is heavy. Ensure that two people are available to remove this item.*

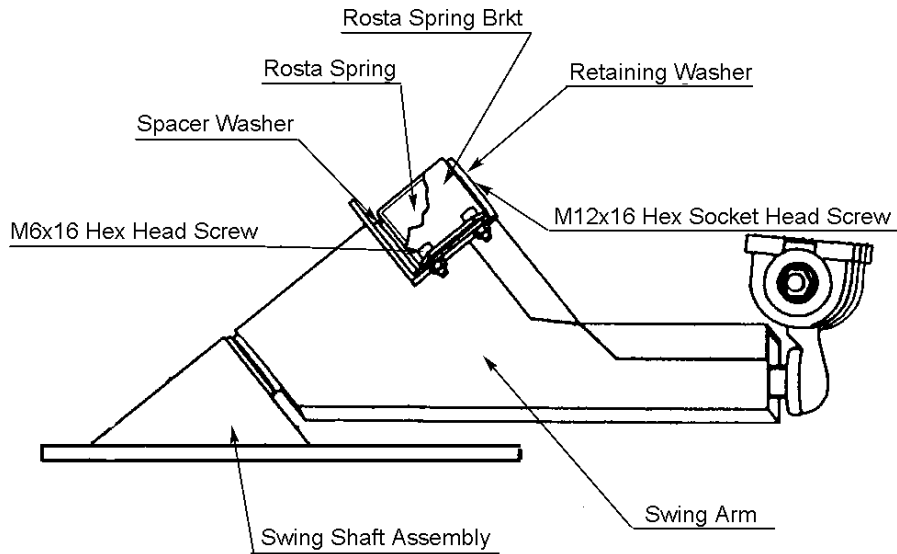

21. Remove the Hex Socket Head Screw (M12x16) and remove the Retaining Washer.
22. Remove 4 off Hex Head Screws (M6x16) and remove the Rosta Spring Bracket.
23. Slide the Rosta Spring off the shaft.
24. Remove the Spacer Washer and slide the Swing Arm Assembly off the shaft.
25. Repeat steps 21 - 24 to remove the other Swing Arm Assembly.

#### **CAUTION**

**All Hex Head Screws must have Loctite 242 applied to the thread when being refitted.**

**Ensure that all Spring and Flat Washers are refitted and all screws tightened fully. Failure to comply could lead to screws coming loose and creating a danger by causing injury or damage.**

***Note: Take care not to spill Loctite 242 onto any painted surfaces as it could damage the paint.***

**Take care when reassembling not to squash or bend the Air Tubes or to trap any wires.**

26. Apply a thin coating of grease to the full length of each of the shafts on the new Rosta Spring Shaft Assembly.
27. Slide the Swing Arm Assembly onto the shaft and replace the Spacer Washer.  
*Ensure that the Swing Arm is fully on the shaft and that it swings freely.*
28. Slide the Rosta Spring onto the shaft until it is in contact with the Spacer Washer.
29. Refit the Rosta Spring Bracket using the 4 off Hex Head Screws (M6x16).
30. Replace the Spacer Washer and fit and tighten fully the Hex Socket Head Screw (M12x16).

31. Repeat steps 27-30 to fit the other Swing Arm Assembly.
32. Replace the Rosta Spring Shaft Assembly to the Main Base Assembly and fit, finger tight, the 7 off Hex Head Screws (M6x25). Fully tighten the screws.  
*Note: This item is heavy. Ensure that two people are available to replace this item.*

33. Replace the Ride Assembly on to the bearings and Joint Box making sure that the wires and air tube are passed through and taking care not to trap fingers or clothing.  
*Note: This item is heavy. Ensure that two people are available to replace this item.*

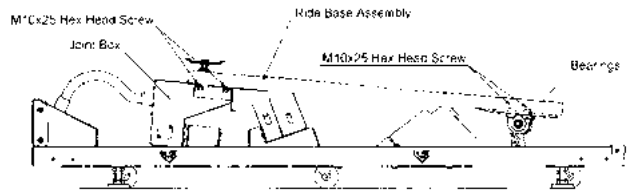

34. Fit, finger tight, the 8 off Hex Head Screws (M10x25) to retain the Ride Assy to the Bearings.
35. Push the Ride Base forward to align the holes in the Joint Box with the threaded holes in the Ride Base and fit the 4 off Hex Head Screws (M10x25). Tighten fully all 12 Hex Head Screws (M10x25).

36. Replace the Stand-On Metal Plate on to the Ride Base making sure that the wires and air tube are passed through.

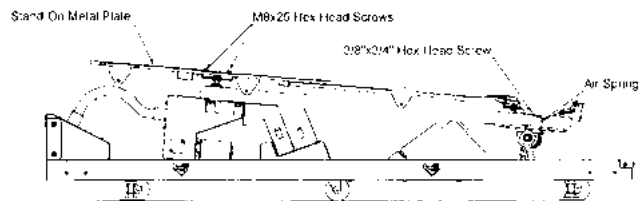

37. Fit, finger tight, the 2 off Hex Head Screws ( $\frac{3}{8} \times \frac{3}{4}$  AF) to the top of the air spring.

38. Fit, finger tight, the 8 off Hex Head Screws (M8x25) retaining the Stand-On Metal Plate to the Ride Assembly. Tighten fully the M8x25 and  $\frac{3}{8} \times \frac{3}{4}$  AF screws.

39. Replace the Wooden Plate ensuring that the wires and air tube pass into the tank speaker box and are not trapped.

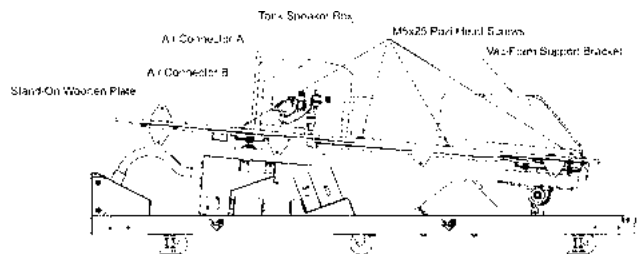

40. Replace the Vac-Form Support Brackets and retain finger tight using 4 off Pozi Head Screws (M5x25).  
*Note: The Vac-Form support Brackets are handed. Ensure that they are fitted the correct way.*

41. Fit, finger tight 6 off Pozi Head Screws (M5x25) retaining the Wooden Plate to the Stand-On Metal Plate. Tighten fully all ten (M5x25) screws.
42. Reconnect the 15way connector and refit the Earth wire, using the Pozi Head Screw (M4x12), in the Tank Speaker Box. Ensure that the Earth Wire connection is tight.

43. Reconnect the two 2way connectors on the air valves. (The plugs can go into either socket)

44. Refit the Air Tubes to connectors A and B. The tubes are just pushed fully into the connectors.

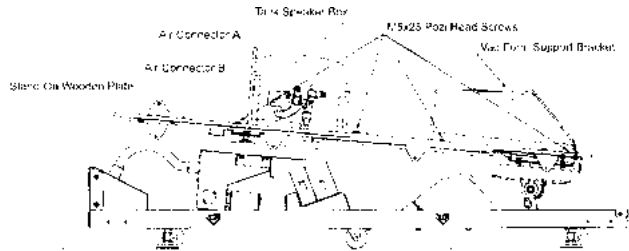

45. Raise the level adjusters on the ride base and move it to the monitor cabinet. Reconnect the Air Tube from the Ride Base to the Monitor Cabinet. Turn the machine ON and listen for any air leaks. If there are any leaks push the air tubes in fully until the connection is sealed. Turn the machine OFF and disconnect from the mains. Disconnect the air tube from the monitor cabinet and move the Ride Base away from the monitor cabinet and lower the level adjusters again.

46. Place the Control Arm Assembly onto the Wooden Plate and fit, finger tight, the 8off Hex Head Screws (M8x45). Tighten fully all of the M8x25 screws. *Note: This item is heavy. Ensure that two people are available to replace this item.*

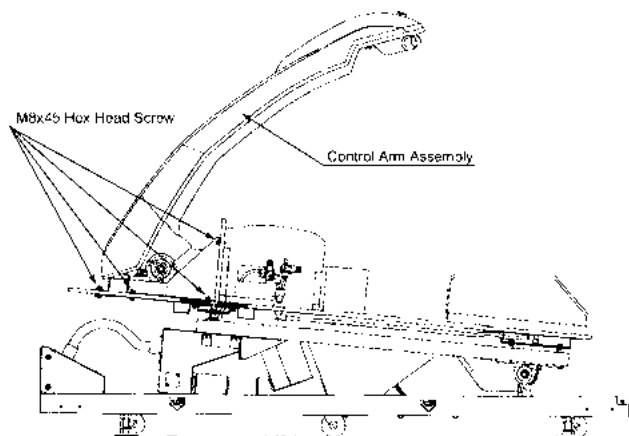

47. Reconnect the 3way and 15 way connectors to the Control Arm Assembly and make sure that the wires are re-clipped and do not get caught or are under strain when the Control Arm is moved up and down.

48. Refit the rear Vac-Form using 2off Security Head Screws (M5x16).

49. Refit the Side Vac-Forms using the 6off Security Screws (M5x16). (3ea side)

50. Refit the Stand-On Vac Form using the 4off Security Screw (M5x16) and 4off Security Screw (M5x20).

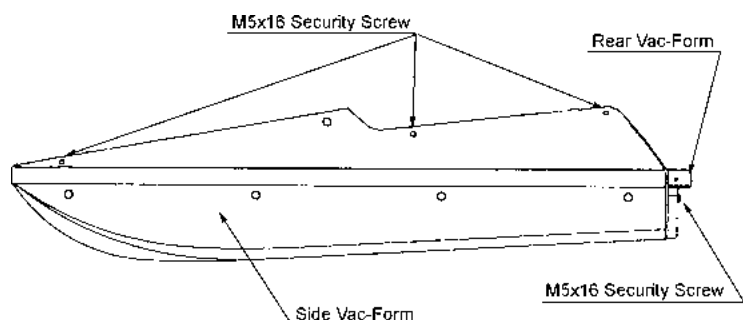

51. Refit the Tank Vac-Form using 4off Security Head Screw (M5x16) and 4off Security Head Screw (M5x20).

52. Refit the Vac-Form Closing Bracket using 4off Security Head Screw (M5x16).

53. Ensure that all Security Head Screws are fully tightened.

54. Replace the Rubber Skirts and fixing brackets using the 8off Security Head Screws (M5x30) 4ea side.

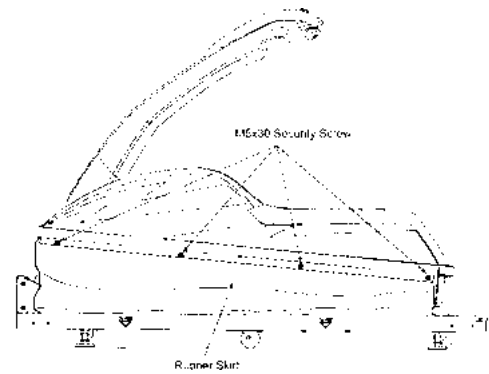

55. Raise the level adjusters on the Ride Base and move the Ride Base to the Monitor Cabinet.
56. Reconnect the air tube and loom connectors. Refit the 4off Hex Head Screws (M8x60) to join the Ride Assembly to the Monitor Cabinet, ensuring that the air tube or wiring is not trapped.
57. Lower the level adjusters on the Ride Base so that the castors are approx. 5mm from the ground. Tighten the locking nut on each level adjuster to prevent it from moving.
58. Reconnect the mains lead and turn the machine back ON.
59. **Re-initialize the game.**
- a) Ensure that the Control Arm assembly and the Ride assembly are in the neutral stand-by position.
  - b) Slide the Test Switch "ON" while pressing the Service Button. The "VOLUME INITIALIZE" screen will be displayed.
  - c) At this time the Ride assembly and the Accelerator Lever are initialized.
  - d) Press the Start Button to initialize the Control Arm. The "HANDLE POLE ADJUST" screen will be displayed.
  - e) Move the Control Arm fully UP and then fully DOWN. The motion will be registered as the limits of the Control Arm.
  - f) Slide the Test Switch to the OFF position to end initialization and to return to normal game mode.

REPLACEMENT IS NOW COMPLETED