



ROOF VENTILATORS

better AIRFLOW
by DESIGN™



HRV HOODED ROOF VENTILATORS

- Supply or exhaust applications
- Direct drive (HRVD) or belt drive (HRVB) arrangements
- Spark resistant, cast aluminum airfoil axial impeller
- Aerodynamically efficient performance
- Heavy duty welded steel base
- Aluminum hood with birdscreen
- TEFC industrial duty motor
- Sizes range from 24" to 60"

HRV HOODED ROOF VENTILATORS

STANDARD FEATURES & BENEFITS

- Supply or exhaust applications
- Direct drive (HRVD) or belt drive (HRVB) arrangements
- Spark resistant, cast aluminum airfoil axial impeller
- Factory set adjustable pitch blades
- Aerodynamically efficient performance
- Heavy duty welded steel base
- Air dried enamel paint finish
- Aluminum hood with birdscreen
- TEFC industrial duty motor
- Direct drive units are easily maintained – no belts or pulleys
- Belt drive units have self-aligning pillow block bearings
- Belt drive units use v-belt drive for low speed operation



APPLICATIONS

- Fume and smoke exhaust
- Make-up air
- Heat exhaust
- General ventilation
- Filtered air supply

ACCESSORIES / OPTIONS

- Filtered intake unit
- Gravity shutter for exhaust only
- Pre-fabricated roof curb
- Custom curb panel to match existing curb
- Epoxy or Eisenheiss coatings
- 2" thick disposable filters, for filtered intake unit
- Variable pitch sheaves for easy & accurate adjustment
- Disconnect switch – mounted, or mounted & wired
- Motor operated damper for supply or exhaust applications
- Explosion proof & special duty motors

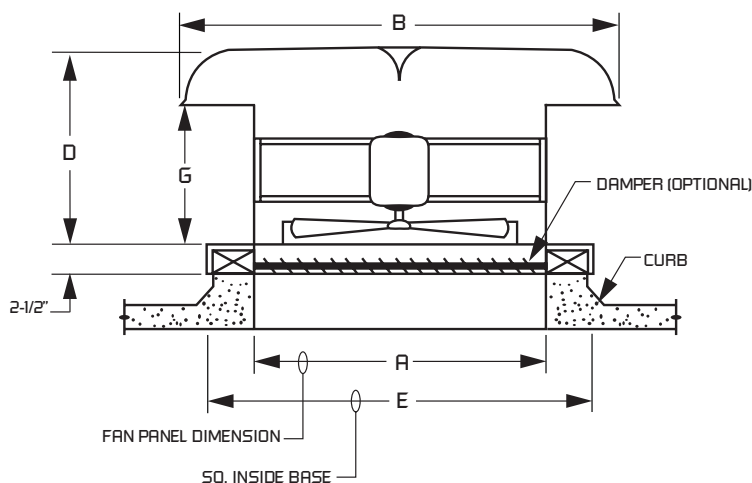

MODEL	DIMENSIONS IN INCHES*						WT (LBS) LESS MTR	MAX MTR FRAME	HP
	A	B	D	E	G				
HRV-24	30	54 x 64	41.5	39	25.5	324	145T	1/4 - 1	
HRV-30	36	60 x 76	41.5	45	25.5	365	145T	1/3 - 1 1/2	
HRV-36	42	72 x 82	45.5	51	27.5	410	145T	1/3 - 2	
HRV-42	48	80 x 89	45.5	57	27.5	503	184T	1/2 - 3	
HRV-48	54	87 x 95	49.5	63	29.5	630	184T	3/4 - 5	
HRV-54	60	92 x 98	50.5	69	29.5	870	215T	1 - 5	
HRV-60	66	90 x 107	54.5	75	31.5	1140	215T	1 - 10	

MODEL	PERFORMANCE RATING		
	MINIMUM CFM	MAXIMUM CFM	MAXIMUM CFM WITH FILTERS
HRV-24	800	6,700	4,861
HRV-30	800	11,800	11,800
HRV-36	1,800	15,376	13,889
HRV-42	3,300	22,296	16,000
HRV-48	4,283	30,900	18,750
HRV-54	8,000	35,238	19,333
HRV-60	9,600	47,000	21,333

*DO NOT USE FOR CONSTRUCTION

CONSULT FACTORY FOR CERTIFIED PRINTS

HRV HOODED ROOF VENTILATORS

PRODUCT SPECIFICATION GUIDE

1.0 GENERAL

- A. Fans shall be model HRVD Direct Drive or HRVB Belt Drive Hooded Roof Ventilators as manufactured by Continental Fan Manufacturing Inc., of Buffalo, NY, and of the size and capacity as indicated on the drawings and fan schedule.
- B. HRVD or HRVB Hooded Roof Ventilators shall be furnished as either supply or exhaust as indicated on the drawings and fan schedule.
- C. HRVD or HRVB Hooded Roof Ventilators configured for supply shall be furnished with filters as indicated on the drawings and fan schedule.
- D. Fans shall be rated and tested in accordance with ANSI/AMCA Standard 210-99.
- E. All motors and electrical components shall conform to NEMA standards.

2.0 FAN HOUSING - DIRECT DRIVE MODEL HRVD

- A. Fan shall be axial flow, roof mount, and direct drive configuration consisting of a hood section and fan housing with curb base.
- B. Fan housing and curb base shall be of welded heavy gauge steel construction.
- C. Fan motor base shall consist of heavy gauge steel welded directly to fan housing.
- D. Fan housing and motor base shall be coated with an air dried gray enamel finish.
- E. Fan shall have an aluminum hood with bird screen.

2.1 FAN HOUSING - BELT DRIVE MODEL HRVB

- A. Fan shall be axial flow, roof mount, and belt drive configuration consisting of a hood section and fan housing with curb base.
- B. Fan housing and curb base panel shall be of welded heavy gauge steel construction.
- C. Fan motor, shaft and bearings support base shall consist of heavy gauge steel welded directly to fan housing.
- D. Fan housing and motor base shall be coated with an air dried gray enamel finish.
- E. Fan shall have an aluminum hood with bird screen.

3.0 FAN IMPELLER

- A. Axial impeller shall be constructed of spark resistant, die cast aluminum airfoil shaped blades secured to a die cast aluminum hub assembly.
- B. Axial impeller blades shall be of adjustable pitch construction with multiple hub-to-blade arrangements to maximize air performance. Blade pitch angles shall be factory set.
- C. Axial impeller hub shall be designed to incorporate a split taper bushing, and be keyed directly to drive shaft.

4.0 FAN MOTOR AND DRIVE

- A. Motor shall be TEFC industrial duty and conform to NEMA standards.
- B. Motor shall be of voltage, horsepower, RPM and enclosure as indicated on the fan schedule.
- C. Fan sheaves shall be cast iron and appropriately sized and aligned.
- D. Fan belts shall be static conducting, plus oil and heat resistant.
- E. Fan shaft shall be steel, turned, ground and polished.
- F. Fan shaft bearings shall be lubricated, self-aligning ball type in cast iron pillow block mounts with external grease fittings.

5.0 OPTIONAL FAN ACCESSORIES

- A. Where indicated, fan shall be provided with the following optional accessories:
 - Disconnect switches – mounted, or mounted and wired
 - NEMA 3R non-fused
 - NEMA 4X non-fused
 - Motors
 - Explosion proof
 - Special duty
 - Protective coatings
 - Epoxy
 - Eisenheiss
 - Variable pitch sheaves
 - Pre-fabricated roof curbs
 - 2" disposable filters, for filtered intake unit
 - Motor operated damper (supply or exhaust)
 - Gravity shutter for exhaust only
 - Custom curb base
 - Inspection door

6.0 FAN TESTING

- A. Axial impeller shall be balanced and mounted in fan assembly.
- B. Fan assembly shall be run and tested prior to shipment.
- C. A test report shall be maintained on file for each individual fan.

Industrial Fan Division

The Industrial Fan Division offers superbly crafted industrial fans and ventilators, expertly supported by a network of independent manufacturers' representatives.



Panel Fans

Centrifugal Fans

Flange Fans

In-line Fans

Roof Ventilators

Iris Dampers

OEM Fan Division

The OEM Fan Division works closely with original equipment manufacturers to meet their design requirements, offering in-stock fan components, 3D models and custom fan solutions.



Cabinet Cooling Fans

Motorized Axials

Motorized Impellers

Centrifugal Fans

Axial Impellers

Centrifugal Impellers

Wholesale Products Division

The Wholesale Products Division offers a superior line of in-stock commercial and residential ventilation products, available from wholesalers and distributors across North America.



Bathroom Fans

Air Purification Systems

In-Line Duct Fans

External Mount Fans

Radial Blade Blowers

Exhaust Fans

USA

www.continentalfan.com

Continental Fan Manufacturing Inc.
203 Eggert Road, Buffalo, NY 14215
Tel: (716) 842 0670 Fax: (716) 842 0611

Canada

www.aeroflo.com

Aeroflo Inc.
12-205 Matheson Blvd. E., Mississauga, ON L4Z 3E3
Tel: (905) 890 6192 Fax: (905) 890 6193

HRV HOODED ROOF VENTILATORS

