

Duct Cover Short/Long

Z1C-00TI

Z1C-01TI

For use with Tilt range hood

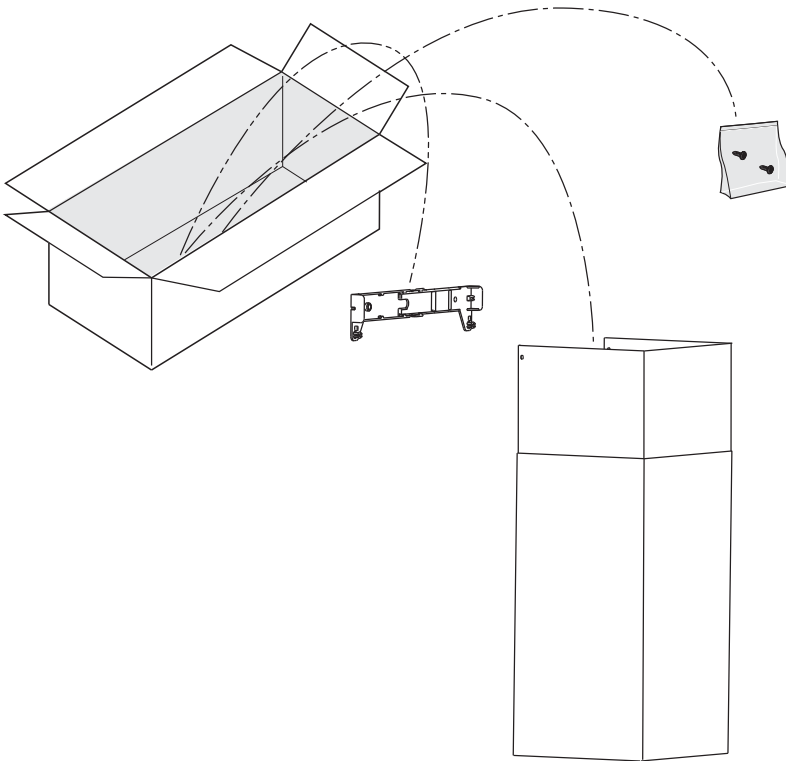

USA	Mounting the duct cover	Pag. 3
F	Fixation des cheminées	Pag. 4
E	Fijación de las chimeneas	Pag. 5
I	Fissaggio dei camini	Pag. 6

DUCT COVER EXTENSION SPECIFICATION

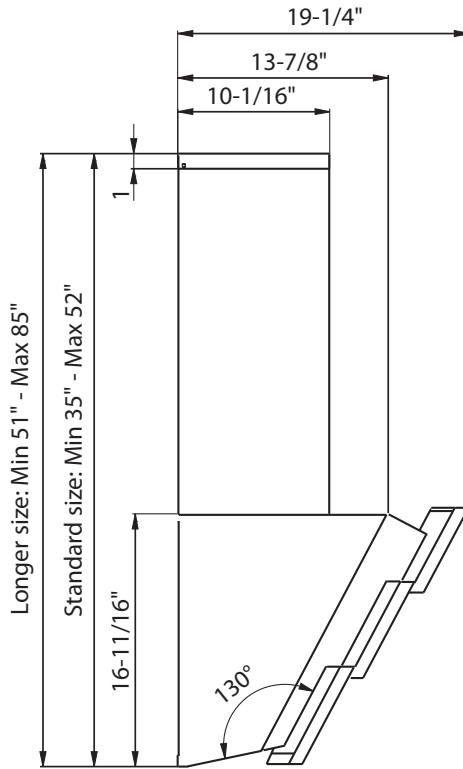

■ MOUNTING THE DUCT COVER

1. Open the front panel. Fig.1

NOTE! Open the front panel while holding it by its external sides, as shown in Fig.1, and keep at a suitable distance to avoid impacting it.

2. Remove the Decorative Mesh Filters.

3. Loosen the two screws inside the hood that fasten the canopy. Fig.2

4. Slide the top cover off by lifting it. Fig.3

5. Adjust the width of the duct cover support bracket so that it fits inside the top of the chimney and observing the distance shown in Fig. 4

6. Secure duct cover bracket to top of wall just below the ceiling using (2) screws provided. See Fig.5

7. Place correct size ducting for your installation (not supplied) to the hood and secure to the blower collar with aluminum duct tape. Fig. 6

8. Insert top duct cover into bottom duct cover. Seat the duct covers correctly on the hood.

9. Extend top duct cover up and secure to the duct cover bracket using (2) screws. See Fig. 7

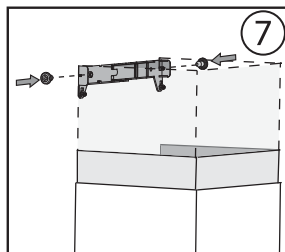
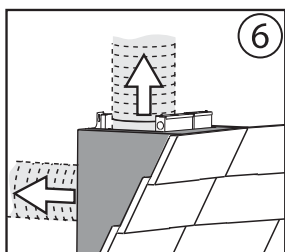
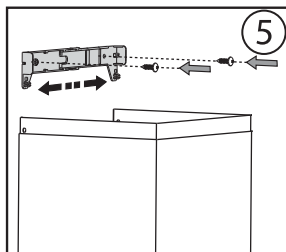
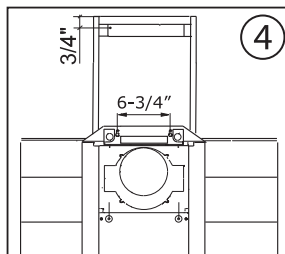
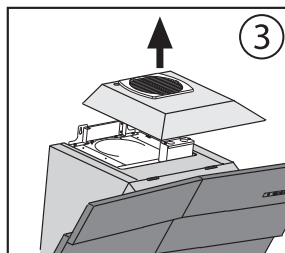
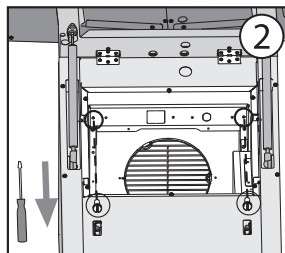
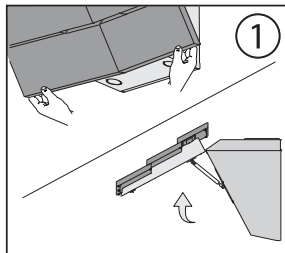

■ FISSAGGIO DEI CAMINI

1. Ouvrir la porte. Fig.1

NOTE! Ouvrir la face en agissant sur les pièces extérieures (voir. Fig.1) et en veillant à se tenir à une distance raisonnable afin d'éviter les chocs.

2. Retirez le panneau.

3. Dévissez les deux vis qui retiennent le chapeau à l'intérieur de la hotte. Fig.2

4. Retirer le chapeau en le faisant glisser vers le haut. Fig.3

5. Réglez la largeur de l'étrier de support de la cheminée afin qu'il s'insère à l'intérieur de la cheminée supérieure et respectez la distance indiquée dans la Fig. 4

6. Fixez l'étrier à la paroi à peine sous le plafond en utilisant les (2) vis. Fig.5

7. Positionnez le conduit (non fourni) proportionné à l'installation sur la hotte et fixez-le au collier sur la bouche de la sortie d'air du moteur en utilisant le ruban aluminium spécial. Fig. 6

8. Insérez la cheminée supérieure à l'intérieur de la cheminée inférieure. Positionnez les cheminées dans le logement spécial sur la hotte.

9. Extraire le tube supérieur en le portant jusqu'à l'étrier et le fixer avec les (2) vis. Fig. 7

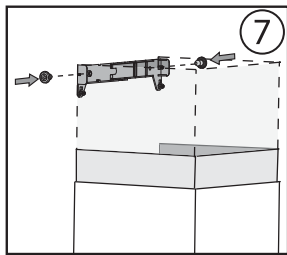
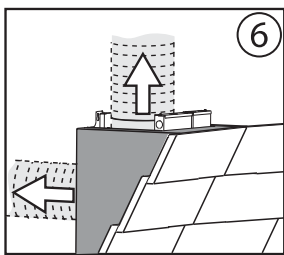
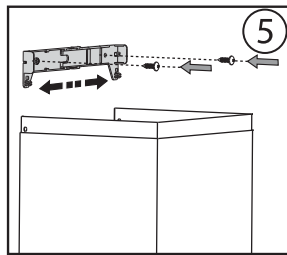
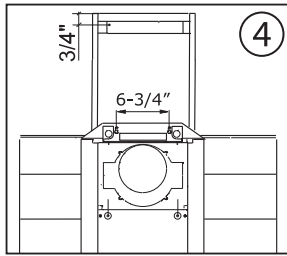
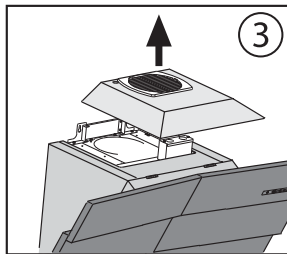
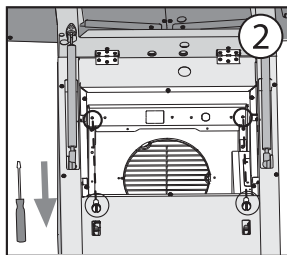
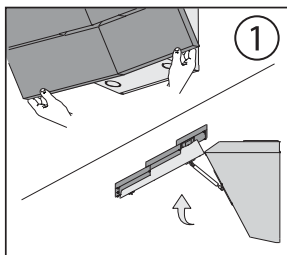

■ FISSAGGIO DEI CAMINI

1. Abra el panel frontal. Fig.1

NOTA! Abra la parte delantera tomándola de las partes externas como se muestra en la Fig.1 y manténgase a una debida distancia para evitar el golpe.

2. Quite el panel.

3. Desenrosque los dos tornillos del interior de la campana, que fijan la cúpula. Fig.2

4. Quite la cúpula deslizándola hacia arriba. Fig.3

5. Regule el ancho de la abrazadera de sostén de la chimenea para que quede dentro de la chimenea superior y respetando la distancia indicada en la fig. 4

6. Fije la abrazadera en la pared apenas debajo del techo utilizando los (2) tornillos. Fig.5

7. Coloque el conducto (no suministrado) de dimensiones adecuadas a la instalación, en la campana y fíjelo al collar arriba de l'abertura de la salida de l'aire del motor, mediante una cinta de aluminio. Fig. 6

8. Introduzca la chimenea superior dentro de la chimenea inferior. Coloque las chimeneas en su lugar en la campana.

9. Extraiga el tubo superior llevándolo hasta la abrazadera y fíjelo con los (2) tornillos. Fig. 7

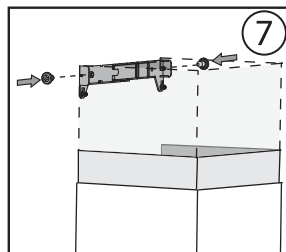
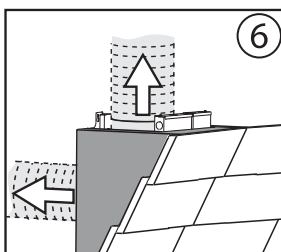
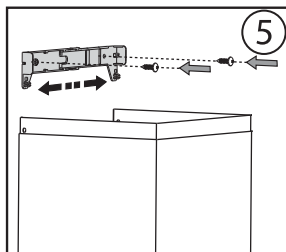
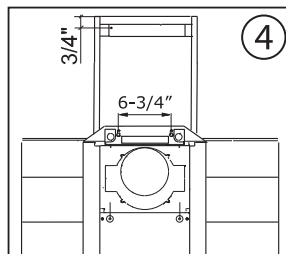
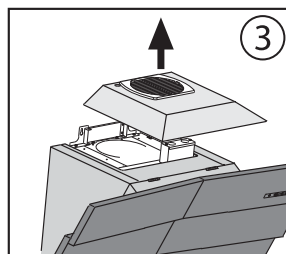
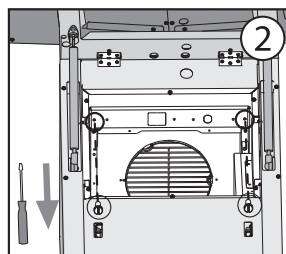
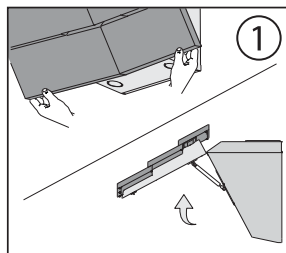



Installazione - Fissaggio Camini

■ FISSAGGIO DEI CAMINI

1. Aprire lo sportello. Fig.1

NOTA! Aprire il frontale prendendolo nelle parti esterne, come illustrato in Fig.1, e fare attenzione di tenersi a debita distanza per evitare l'urto.

2. Rimuovere il pannello alluminio.

3. Svitare le due viti all'interno della cappa, che fissano il cupolino. Fig.2

4. Togliere il cupolino sfilandolo e alzandolo verso l'alto. Fig.3

5. Regolare la larghezza della staffa supporto camino in modo che sia inserita all'interno del camino superiore e rispettando la distanza indicata in Fig. 4

6. Fissare la staffa sulla parete appena sotto il soffitto utilizzando le (2) viti. Fig.5

7. Posizionare il condotto (non in dotazione) con dimensioni adatte all'installazione sulla cappa e fissarlo alla bocca uscita aria del motore mediante l'apposito nastro di alluminio. Fig. 6

8. Inserire il camino superiore dentro al camino inferiore. Posizionare i camini nell'apposita sede sulla cappa.

9. Estrarre il tubo superiore portandolo fino alla staffa e fissarlo con le (2) viti. Fig. 7

