

MAJESTIC VERMONT *Castings*

INSTALLER/CONSUMER SAFETY INFORMATION

PLEASE READ THIS MANUAL
BEFORE INSTALLING AND
USING APPLIANCE

WARNING!
IF THE INFORMATION IN THIS
MANUAL IS NOT FOLLOWED
EXACTLY, A FIRE OR EXPLO-
SION MAY RESULT CAUSING
PROPERTY DAMAGE, PER-
SONAL INJURY OR LOSS OF
LIFE.

FOR YOUR SAFETY
Installation and service must
be performed by a qualified
installer, service agency or
the gas supplier.

WHAT TO DO IF YOU SMELL GAS:

- Do not try to light any
appliance.
- Do not touch any electric
switch; do not use any phone in
your building.
- Immediately call your gas
supplier from your neighbor's
phone. Follow the gas suppliers
instructions.
- If you cannot reach your gas
supplier call the fire
department.

DO NOT STORE
OR USE GASOLINE OR
OTHER FLAMMABLE VAPORS
AND LIQUIDS IN THE VICINITY
OF THIS OR ANY OTHER
APPLIANCE.

Rear Vented Direct Vent Gas Fireplace Model: **DVR33**

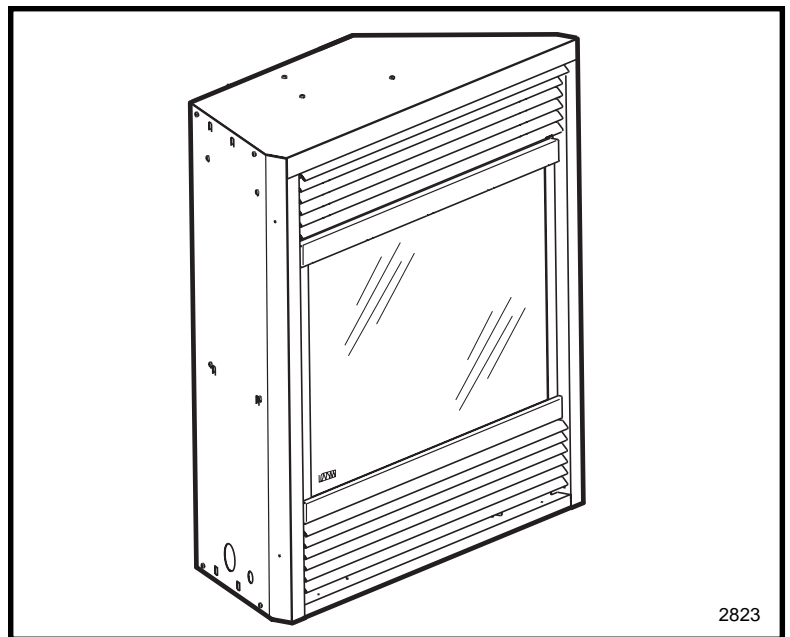

Homeowner's Installation and Operating Manual



Vermont Castings, Majestic Products

410 Admiral Blvd. • Mississauga, Ontario, Canada L5T 2N6 • 905-670-7777
www.majesticproducts.com • www.vermontcastings.com

INSTALLER: DO NOT DISCARD THIS MANUAL - LEAVE FOR HOMEOWNER

10004920 01/03 Rev.0

Table of Contents

PLEASE READ THE INSTALLATION & OPERATING INSTRUCTIONS BEFORE USING THE APPLIANCE.

Thank You and Congratulations on Your Purchase of a Vermont Castings, Majestic Products Fireplace.

IMPORTANT: Read all instructions and warnings carefully before starting installation. Failure to follow these instructions may result in a possible fire hazard and will void the warranty.

Installation and Operating Instructions

Important Curing/Burning Instructions	3
Proposition 65 Warning	3
Locating Your fireplace	3
Fireplace Dimensions	4
Clearance to Combustibles	5
Mantels	5
Hearth	5
Framing & Finishing	6
Final Finishing	6
Gas Specifications	6
Gas Inlet and Manifold Pressures	6
Gas Line Installation	7
Remote ON/OFF Switch Installation	7
Alternate Switch Location	7
EB-1 Electrical Box	8
Electronic Gas Control Valve	9

General Venting Information/Termination Location/ Clearances 9 – 11

General Information for Connecting Vent Pipes 11

Crimped End Pipes/Twist Lock Pipes	11, 12
Rear Wall Vent Application/ Installation	12, 13
How to Use the Vent Graph	14
Vertical Sidewall Application/ Installation	14 – 17
Below Grade Installation	17, 18
Vertical Through-the-Roof Applications & Installations	18, 19
DVR33 Bracket Restrictor Installation	20
Twist Lock/ Crimped End Venting Components	21, 22

Operating Instructions

Glass Information	23
Louvre Removal	23
Window Frame Assembly Removal	23
Glass Cleaning	23
Installation of Logs and Lava Rock Material	24
Flame and Temperature Adjustment	24
Flame Characteristics	25
Inspecting the Venting System	25
Lighting and Operating Instructions	26, 27
Troubleshooting Guides	28 – 30
Fuel Conversion Instructions	31
General Maintenance	32
Cleaning the Standing Pilot Control System	32

Replacement Parts

Parts Pictorial	33, 34
Parts Number List	34 – 36

Optional Accessories

Fan Kits	37
Hard Wire (Direct) Hook-up	37
Remote Controls	38
Ceramic Refractory Panels	38
Decorative Bay Windows	38
Decorative Frame Trims	39

Installation and Operating Instructions

This gas appliance should be installed by a qualified installer in accordance with local building codes and with current **CSA-B149.1** Installation codes for Gas Burning Appliances and Equipment. If the unit is being installed in a mobile home, the installation should comply with the current **CAN/CSA Z 240.4** code. For U.S.A. Installations follow local codes and/or the current **National Fuel Gas Code, ANSI Z223.1**.

FOR SAFE INSTALLATION AND OPERATION

PLEASE NOTE THE FOLLOWING:

1. This fireplace gives off high temperatures and should be located out of high traffic areas and away from furniture and draperies.
2. Children and adults should be alerted to the hazards of the high surface temperatures of this fireplace, and should stay away to avoid burns or ignition of clothing.
3. Children should be carefully supervised when in the same room as your fireplace.
4. Under no circumstances should this fireplace be modified. Parts removed for servicing should be replaced prior to operating this fireplace again.
5. Installation and any repairs to this fireplace must be performed by a qualified installer, service agency or gas supplier. A professional service person should be contacted to inspect this fireplace annually. Make it a practice to have all of your gas fireplaces checked annually. More frequent cleaning may be required due to excess lint and dust from carpeting, bedding material, etc.
6. Control compartments, burners and air passages in this fireplace should be kept clean and free of dust and lint. Make sure the gas valve and pilot light are turned off before you attempt to clean this fireplace.
7. The venting system (chimney) of this fireplace should be checked at least once a year and if needed your venting system should be cleaned.
8. Keep the area around your fireplace clear of combustible materials, gasoline and other flammable vapor and liquids. This fireplace should not be used as a drying rack for clothing, nor should Christmas stocking or decorations be hung in the area of it.
9. Under no circumstances should any solid fuels (wood, coal, paper or cardboard etc.) be used in this fireplace.
10. The flow of combustion and ventilation air must not be obstructed in any way.
11. When fireplace is installed directly on carpeting, vinyl tile or any combustible material other than wood, this fireplace must be installed on a metal or wood panel extending the full width and depth of the fireplace.
12. This fireplace requires adequate ventilation and combustion air to operate properly.
13. This fireplace must not be connected to a chimney flue serving a separate solid fuel burning fireplace.
14. When the fireplace is not in use it is recommended that the gas valve be left in the OFF position.

PROPOSITION 65 WARNING

Fuels used in gas, wood-burning or oil fired appliances, and the products of combustion of such fuels, contain chemicals known to the State of California to cause cancer, birth defects and other reproductive harm.
California Health & Safety Code Sec. 25249.6

This appliance may be installed in an aftermarket, permanently located, manufactured home, or mobile home where not prohibited by local codes.

This appliance is only for use with type of gas indicated on the rating plate. This appliance is not convertible for use with other gases, unless a certified kit is used.

IMPORTANT: PLEASE READ THE FOLLOWING CAREFULLY

Remove any plastic from trim parts before turning the fireplace On.

It is normal for fireplaces fabricated of steel to give off some expansion and/ or contraction noises during the start up or cool down cycle. Similar noises are found with your furnace heat exchanger or car engine.

It is not unusual for a Vermont Castings, Majestic Products gas fireplace to give off some odor the first time it is burned. This is due to the manufacturing process.

Please open all windows to ensure your room is well ventilated.

It is recommended that you burn your fireplace for at least ten (10) hours the first time you use it. If the optional fan kit has been installed, place the fan switch in the "Off" position during this time.

Locating Your Fireplace

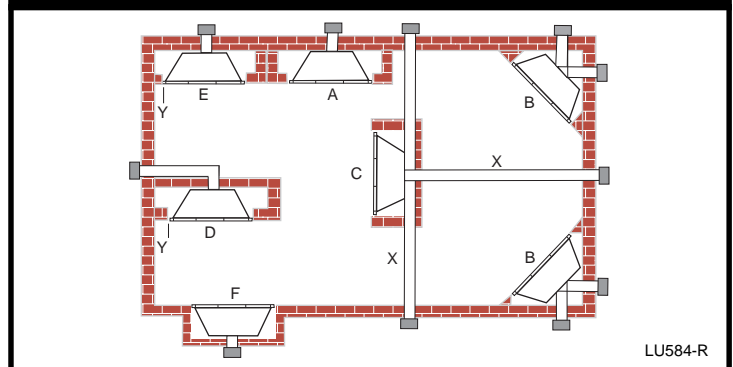

LU584-R

Fig. 1 Locating Your Gas Fireplace

- | | | |
|---------------------|-------------------------|-----------------------|
| A) Flat on wall | B) Cross corner | C) Island** |
| D) Room divider*/** | E) Flat on wall corner* | F) Chase installation |
| | Y) 6 in. minimum | |

Notes (Fig. 1):

* When you install your Vermont Castings, Majestic Products fireplace in (D) Room divider or (E) Flat on wall corner positions, a minimum of (Y), 6 in. (153 mm) clearance must be maintained from the perpendicular wall and the front side edge of the fireplace.

** Island (C) and Room Divider (D) installation is possible if the horizontal portion of the vent system (X) does not exceed 20 ft. (610 cm). See details in Venting Section.

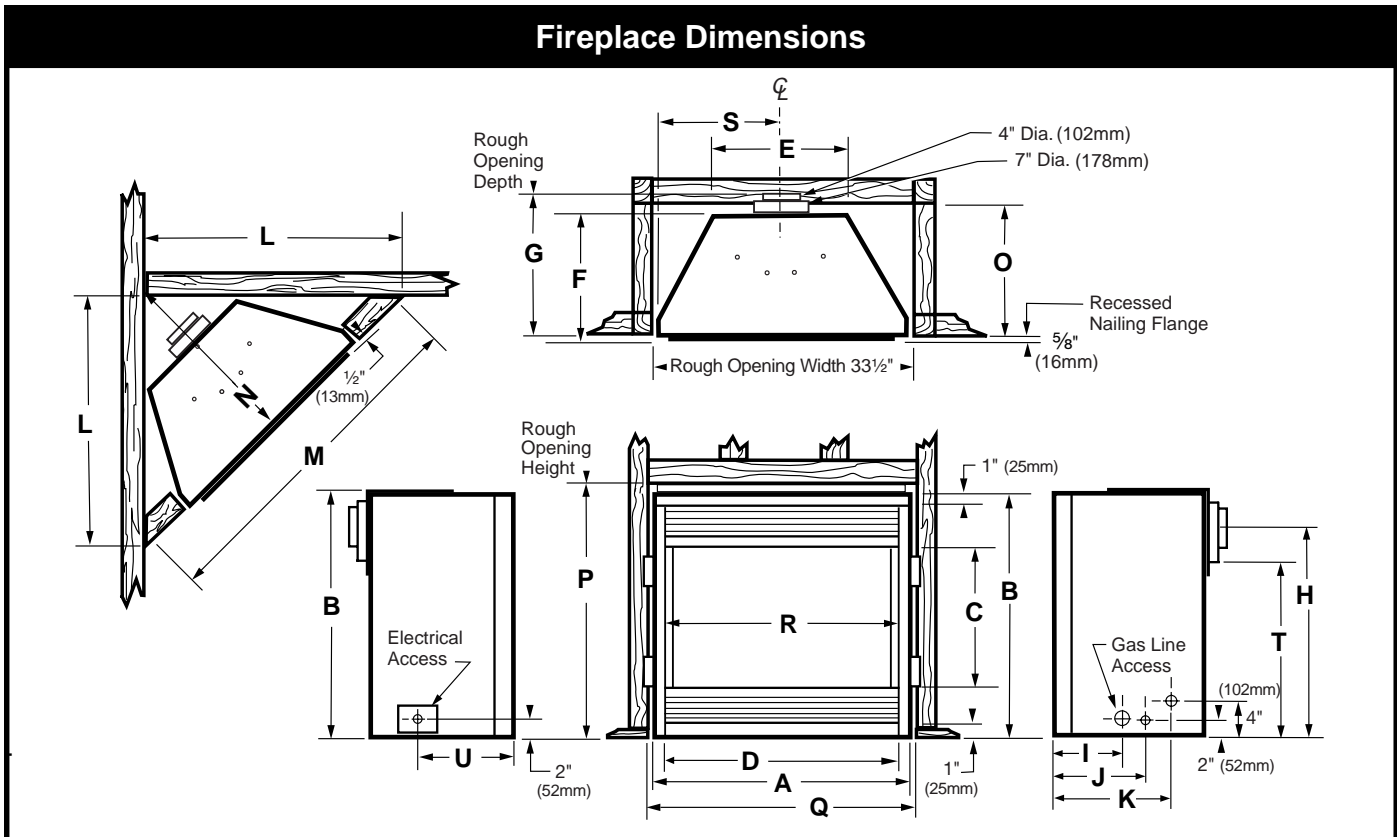

Fig. 2 Fireplace specifications and framing dimensions.

Appliance Dimensions

A	33"	838 mm
B	28 7/8"	733 mm
C	16 3/8"	416 mm
D	31"	787 mm
E	22 1/16"	560 mm
F	11 1/2"	292 mm
G	14 3/4"	375 mm
H	24 1/2"	622 mm
I	5"	127 mm
J	7 1/2"	127 mm
K	8 1/2"	216 mm
R	31"	787 mm
S	16 1/2"	419 mm
T	19 1/2"	495 mm
U	8"	208 mm

Framing Dimensions

L	36"	914 mm
M	51"	1295 mm
N	25 1/2"	648 mm
O	12"	305 mm
P	29"	737 mm
Q	33 1/2"	851 mm

Clearance to Combustibles

Appliance

Top	0" (0 mm)
Bottom	0" (0 mm)
Side	0" (0 mm)
Back	0" (0 mm)

Venting

Concentric sections of DV Vent	1" (25 mm)
Non-concentric sections of DV Vent	
Sides and bottom	1" (25 mm)
Top	2" (50 mm)

Mantels

The height that a combustible mantel is fitted above the fireplace is dependent on the depth of the mantel. This also applies to the distance between the mantel leg (if so fitted) and the fireplace. Refer to Fig. 4a and Fig. 4b, and the Mantel Charts below for the correct mounting height and widths.

The distances and reference points are not affected by the fitting of a bay window front trim kit.

Noncombustible mantels and legs may be installed at any height and width around the appliance.

To prevent discoloration, use only heat-resistant paint or lacquer to finish the mantel.

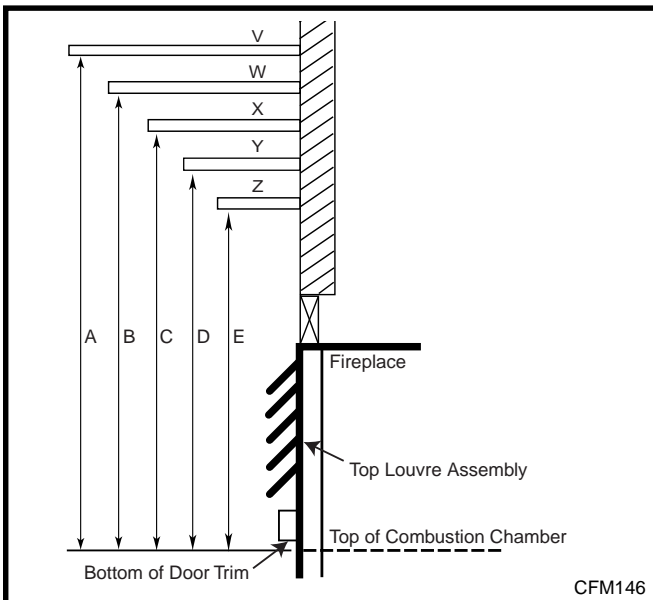

CFM146

Mantel Shelf Dimensions (Minimum Height)

Ref.	Mantel Shelf Depth	Ref.	Height above Firebox
V	10" (254 mm)	A	17" (432 mm)
W	8" (203 mm)	B	15" (381 mm)
X	6" (152 mm)	C	13" (330 mm)
Y	4" (101 mm)	D	11" (279 mm)
Z	2" (50 mm)	E	9" (229 mm)

Fig. 4a Combustible mantel leg minimum installation CFM174

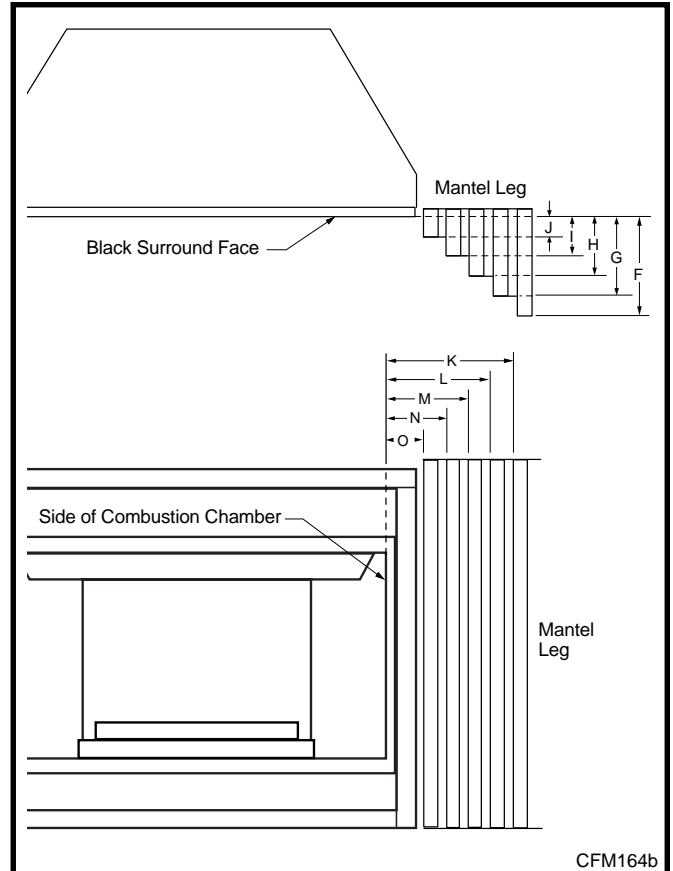

CFM164b

Mantel Leg Dimensions (Minimum Width)

Ref.	Mantel Leg Depth	Ref.	Mantel Leg from Side of Combustion Opening
F	10" (254 mm)	K	11 1/2" (292 mm)
G	8" (203 mm)	L	9 1/2" (241 mm)
H	6" (152 mm)	M	7 1/2" (191 mm)
I	4" (101 mm)	N	5 1/2" (140 mm)
J	2" (50 mm)	O	3 1/2" (89 mm)

Fig. 4b Mantel leg dimensions

CFM166a

Hearth

A hearth is not mandatory, but is recommended for aesthetic purposes. We recommend using a noncombustible hearth which projects out 12" (305 mm) or more from the front of the fireplace.

Cold climate installation recommendation:



When installing this unit against a noninsulated exterior wall or chase, it is mandatory that the outer walls be insulated to conform to applicable insulation codes.

Framing and Finishing



Check fireplace to make sure it is levelled and properly positioned.

1. Choose the unit location.
2. Place the unit into position and secure it to the floor with 1.5" (38 mm) screws, or nails. The holes to secure the unit to floor are located just behind the access door grille on the left and right side of the unit.
3. Frame in the fireplace with a header across the top. It is important to allow for the finished wall face when setting the depth of the frame.
4. Attach the fireplace to the frame using the adjustable frame drywall strips (located behind the access door for shipping). Preset the depth to suit the facing material of the wall. The strips are adjustable to 1/2" (13 mm), 5/8" (16 mm), or 3/4" (19 mm). (Fig. 5)
5. Screw through the slotted holes in the drywall strip and into predrilled holes in fireplace side. Measure from face of fireplace to the face of the drywall strip to confirm the final depth.

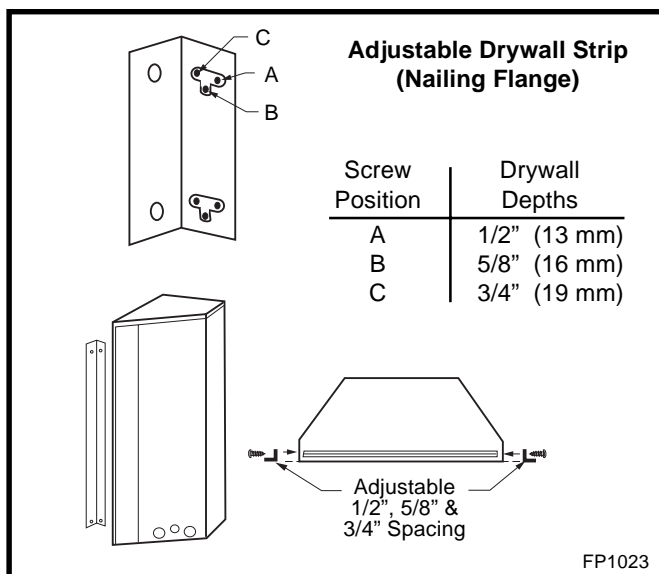

Fig. 5 Adjustable drywall strip (nailing flanges).

Final Finishing

Noncombustible materials such as brick or tile may be extended over the edges of the face of the appliance.

DO NOT cover the window frame assembly, any vent, louvre assembly top or louvre assembly bottom.

If a Trim Kit is going to be installed on the fireplace, the brick or tile will have to be installed flush with the edges of the appliance.

Gas Specifications

Model	Fuel	Gas Control	Max. Input	Min. Input
			BTU/h	BTU/h
DVR33RN	Nat	Millivolt	20,000	14,000
DVR33RP	Prop	Millivolt	20,000	15,000
DVR33EN	Nat	24 V Hi/Lo	20,000	14,000
DVR33EP	Prop	24 V Hi/Lo	20,000	15,000

Gas Inlet and Manifold Pressures

	Natural	LP (Propane)
	Inlet Minimum	5.5" w.c.
Inlet Maximum	14" w.c.	14" w.c.
Manifold Pressure	3.5" w.c.	10" w.c.

DVR33 CERTIFIED TO

**ANSI Z21.88-2002 / CSA 2.33-2002
Vented Gas Fireplace Heaters**

High Elevations

Input ratings are shown in BTU per hour and are certified without deration for elevations up to 4,500 feet (1,370 m) above sea level.

For elevations above 4,500 feet (1,370 m) in USA, installations must be in accordance with the current ANSI Z223.1 and/or local codes having jurisdiction.

In Canada, please consult provincial and/or local authorities having jurisdiction for installations at elevations above 4,500 feet (1,370 m).

Gas Line Installation



When purging the gas lines, the front glass must be removed.

The gas pipeline can be brought in through the side of the fireplace as well as the bottom. Knockouts are provided on the bottom behind the valve to allow for the gas pipe installation and testing of any gas connection. It is most convenient to bring the gas line in from the rear right side of the valve as this allows fan installation or removal without disconnecting the gas line.

The gas line connection can be made with properly tinned 3/8" copper tubing, 3/8" rigid pipe or an approved flex connector. Since some municipalities have additional local codes, it is always best to consult your local authority and the **CSA-B149.1** installation codes.

For USA installations consult the current National Fuel Gas Code, **ANSI Z223.1**.

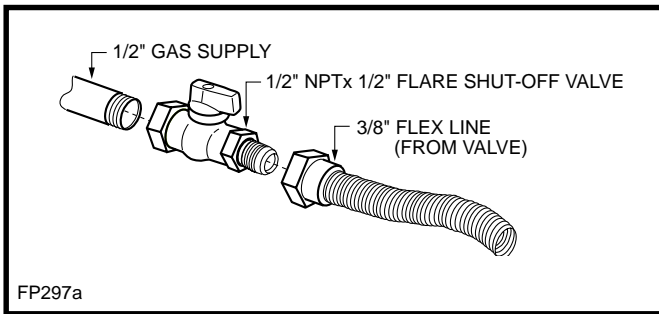

Fig. 6 Typical gas supply installation.



Always check for gas leaks with a mild soap and water solution applied with a brush no larger than 1" (25 mm). Never apply soap and water solution with a spray bottle. Do not use an open flame for leak testing.



Do not subject the fireplace valve to test pressures exceeding 1/2 p.s.i. Isolate, or disconnect this and any other gas appliance control from the gas line when pressure testing.

The gas control is equipped with a captured screw type pressure test point; therefore, it is not necessary to provide a 1/8" test point up stream of the control.

When using copper or flex connector use only approved fittings. Always provide a union when using black iron pipe so that the gas line can be easily disconnected for burner or fan servicing (Fig. 6). See the gas specification for pressure details and ratings.

Remote ON/OFF Switch Installation



Do not wire the remote ON/OFF wall switch for this gas appliance into a 120 V power supply.

1. Thread the wiring through the electrical knockout located on either side of the unit. Take care not to cut the wire or insulation on metal edges. Ensure the wire is secured and protected from possible damage. Run one end of the gas control valve and the other end to the conveniently located wall switch.
2. Attach the wire to the ON/OFF switch and install the switch into the receptacle box. Attach the cover plate to the switch.
3. Connect the wire to the gas control valve (Fig. 7).

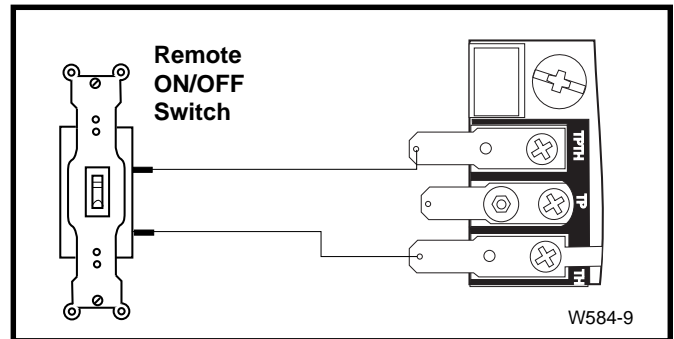

Fig. 7 Remote switch wiring diagram for RN or RP models.

Alternate Switch Location

The remote switch can be installed on either side of the access door. Mount the switch to the bracket provided and screw the bracket to either side of the frame, using the prepunched holes (Fig. 8).

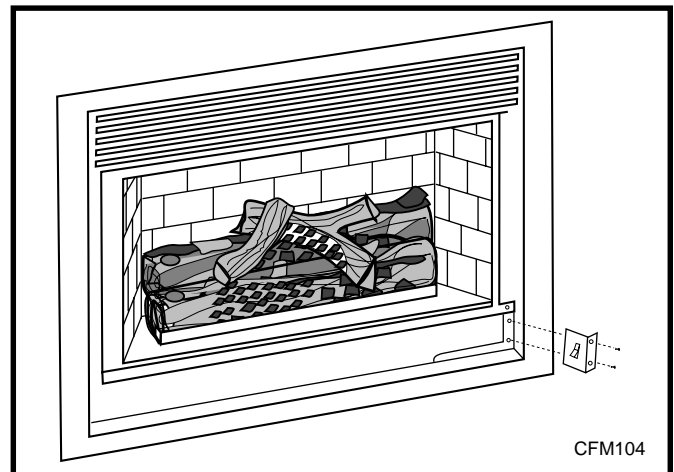

Fig. 8 Alternate switch location.

EB-1 Electrical Box



The fireplace, when installed, must be electrically connected and grounded in accordance with local codes or, in the absence of local codes, with the current CSA C22.1 Canadian Electrical Code



For USA installations, follow the local codes and the national electrical code ANSI/NFPA No. 70.



It is strongly suggested that EB-1 Electrical Junction Box wiring be carried out by a licensed electrician.



Ensure that the power to the supply line has been disconnected before commencing this procedure.

The EB-1 electrical junction box has been supplied standard with this model to allow for easy installation of an optional fan kit.

To connect the EB-1 box to the house electrical supply follow the steps below.

1. Unscrew the retaining screw from the EB-1 base plate (Fig. 9), and remove the EB-1 assembly from the fireplace.
2. Remove the front cover of the EB-1 box.
3. Remove the plug socket assembly from the EB-1 box.
4. Feed the supply line in from the outside through the cable clamp (Fig. 9).
5. Connect black wire of the power supply line to the brass screw (polarized) of the socket assembly.
6. Connect the white wire of the power line to the chrome screw of the socket assembly.
7. Connect the ground wire of the supply line to the green screw of the socket assembly.
8. Refit the socket assembly back into the electrical box and replace the cover plate. Secure the cable with the clamp on the outside of the unit to prevent strain on the connections.
9. The EB-1 electrical junction box is now ready to supply power to the FK-12 or FK-24 fan kits, if so fitted.

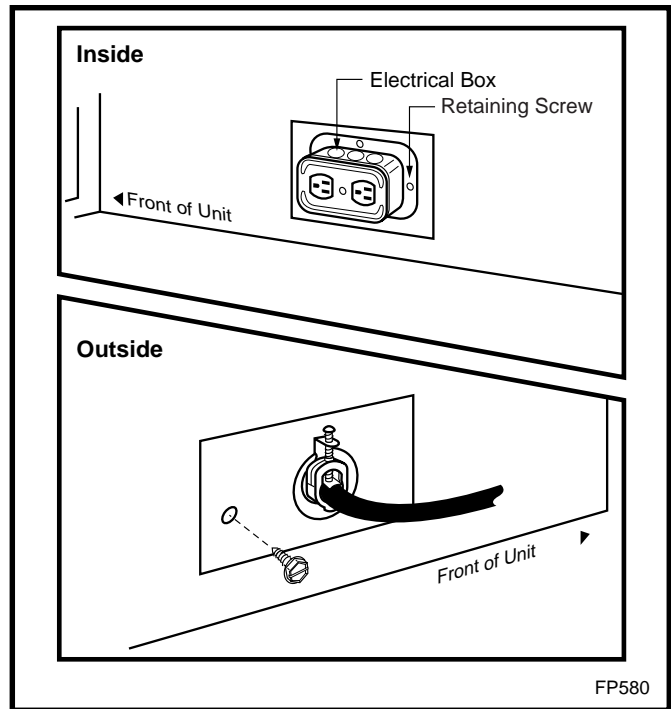

Fig. 9 EB-1 receptacle.

Electronic Gas Control Valve

This appliance may be fitted with a Honeywell Ignition Module.

To install the remote On/Off starter switch on electronic ignition units (Fig. 10):

1. Thread the wiring through the holes on the side panels of the appliance. Take care not to cut the wire or insulation on metal edges. Route the wire to a conveniently located receptacle box.
2. Attach the wire to the On/Off switch and install the switch into the receptacle box.
3. Connect the White wire from the wall switch to the Black wire from the transformer, using an approved wire nut. Connect the Black wire from the wall switch to the Black wire running from the #6 position of the ignition module, also using an approved wire nut.

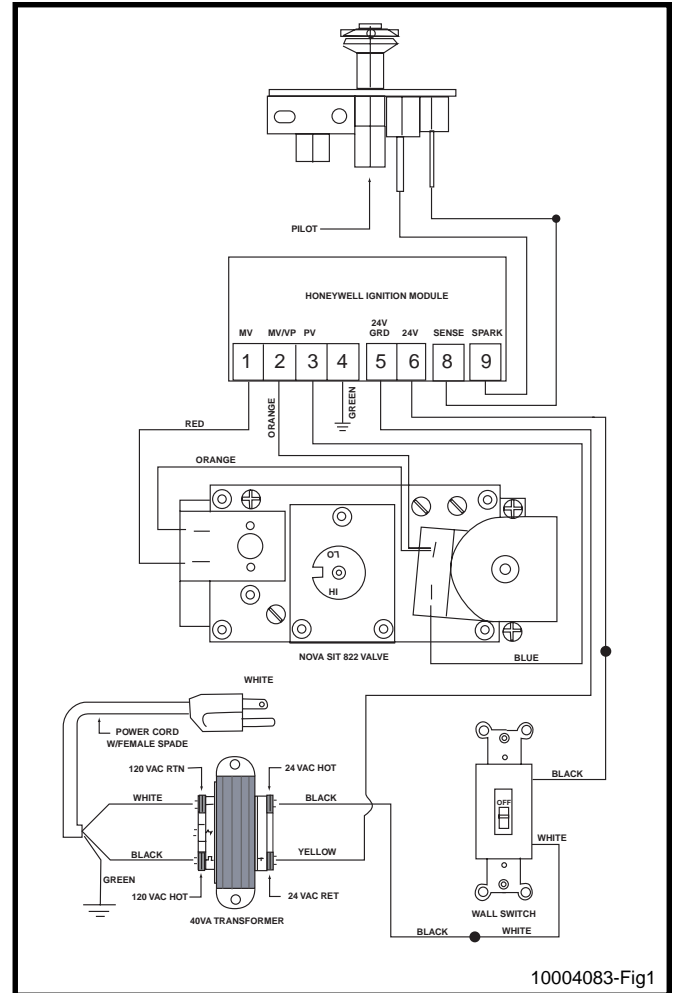

Fig. 10 Honeywell Ignition Module.

General Venting Information

Your fireplace is approved to be vented either through the side wall, or vertically through the roof.

- **Only venting components specifically approved and labeled for this fireplace may be used.**
- Venting terminals shall not be recessed into a wall or siding.
- Horizontal venting must be installed on a level plane without any incline or decline.

There must not be any obstruction such as bushes, garden sheds, fences, decks or utility buildings within 24" from the front of the termination hood.

Do not locate termination hood where excessive snow or ice build up may occur. Be sure to check vent termination area after snow falls, and clear to prevent accidental blockage of venting system. When using snow blowers, make sure snow is not directed towards vent termination area.

Location of Vent Termination



It is imperative to observe minimum clearances (shown on the following page) when locating vent terminations.

General Venting Information—Termination Location

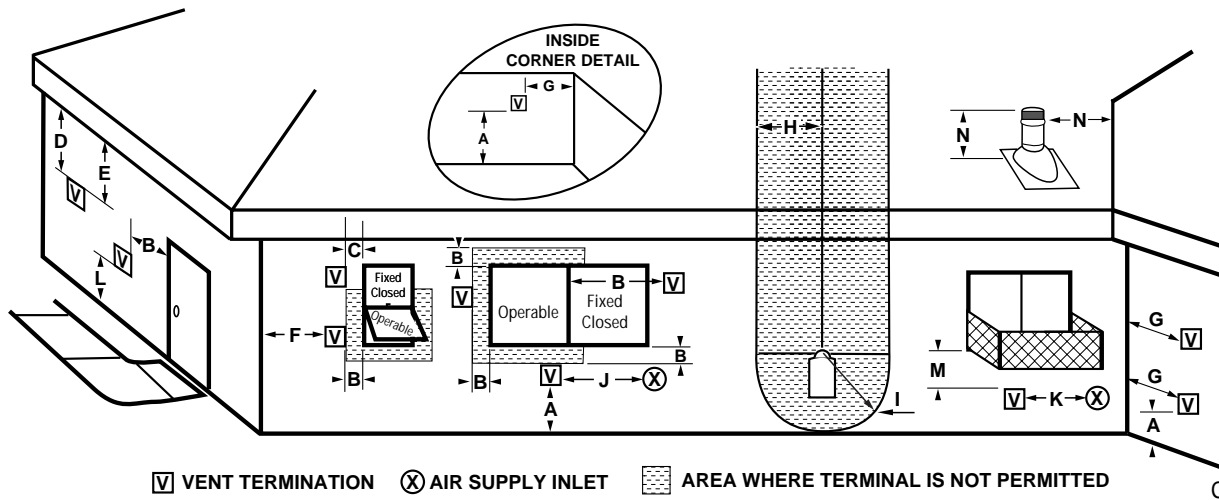

	Canadian Installations ¹	US Installations ²
A = Clearance above grade, veranda, porch, deck or balcony	12 in. (30 cm)	12 in. (30 cm)
B = Clearance to window/door that may be opened	6 in. (15 cm) for appliances <10,000 Btuh (3 kW); 12 in. (30 cm) for appliances >10,000 Btuh (3 kW) and <100,000 Btuh (30 kW); 36 in. (91 cm) for appliances >100,000 Btuh (30 kW)	6 in. (15 cm) for appliances <10,000 Btuh (3 kW); 9 in. (23 cm) for appliances >10,000 Btuh (3 kW) and <50,000 Btuh (15 kW); 12 in. (30 cm) for appliances >50,000 Btuh (15 kW)
C = Clearance to permanently closed window	12 in. (305 mm) recommended to prevent window condensation	12 in. (305 mm) recommended to prevent window condensation
D = Vertical clearance to ventilated soffit located above the terminal within a horizontal distance of 2 ft. (610 mm) from the center line of the terminal	18 in. (458 mm)	18 in. (458 mm)
E = Clearance to unventilated soffit	12 in. (305 mm)	12 in. (305 mm)
F = Clearance to outside corner	(See next page.)	(See next page.)
G = Clearance to inside corner	(See next page.)	(See next page.)
H = Clearance to each inside of center line extended above meter/regulator assembly	3 ft. (91 cm) within a height of 15 ft. (4.57 m) above the meter/regulator assembly	3 ft. (91 cm) within a height of 15 ft. (4.57 m) above the meter/regulator assembly
I = Clearance to service regulator vent outlet	3 ft. (91 cm)	3 ft. (91 cm)
J = Clearance to non-mechanical air supply inlet to building or the combustion air inlet to any other appliance	6 in. (15 cm) for appliances <10,000 Btuh (3 kW); 12 in. (30 cm) for appliances >10,000 Btuh (3 kW) and <100,000 Btuh (30 kW); 36 in. (91 cm) for appliances >100,000 Btuh (30 kW)	6 in. (15 cm) for appliances <10,000 Btuh (3 kW); 9 in. (23 cm) for appliances >10,000 Btuh (3 kW) and <50,000 Btuh (15 kW); 12 in. (30 cm) for appliances >50,000 Btuh (15 kW)
K = Clearance to a mechanical air supply inlet	6 ft. (1.83 m)	3 ft. (91 cm) above if within 10 ft. (3.05 m) horizontally
L = Clearance above paved sidewalk or a paved driveway located on public property	7 ft. (2.13 m)†	7 ft. (2.13 m)†
M = Clearance under veranda, porch, deck or balcony	12 in. (30 cm)‡	12 in. (30 cm)‡
N = Clearance above a roof shall extend a minimum of 24" (610 mm) above the highest point when it passes through the roof surface, and any other obstruction within a horizontal distance of 18" (450 mm).		

1 In accordance with current CSA-B149 Installation Codes.
 2 In accordance with current ANSI Z223.1/NFPA 54 National Fuel Gas Codes.
 † A vent shall not terminate directly above a sidewalk or paved driveway which is located between two single-family dwellings, and which serves both dwellings.
 ‡ Only permitted if veranda/porch/deck is fully open on a of minimum two sides beneath the floor.
 NOTES: • Local codes or regulations may require different clearances.
 • The special venting system used on Vermont Castings, Majestic Products Direct Vent Fireplaces are certified as part of the appliance, with clearances tested and approved by the listing agency.

Fig. 11 Vent termination clearances

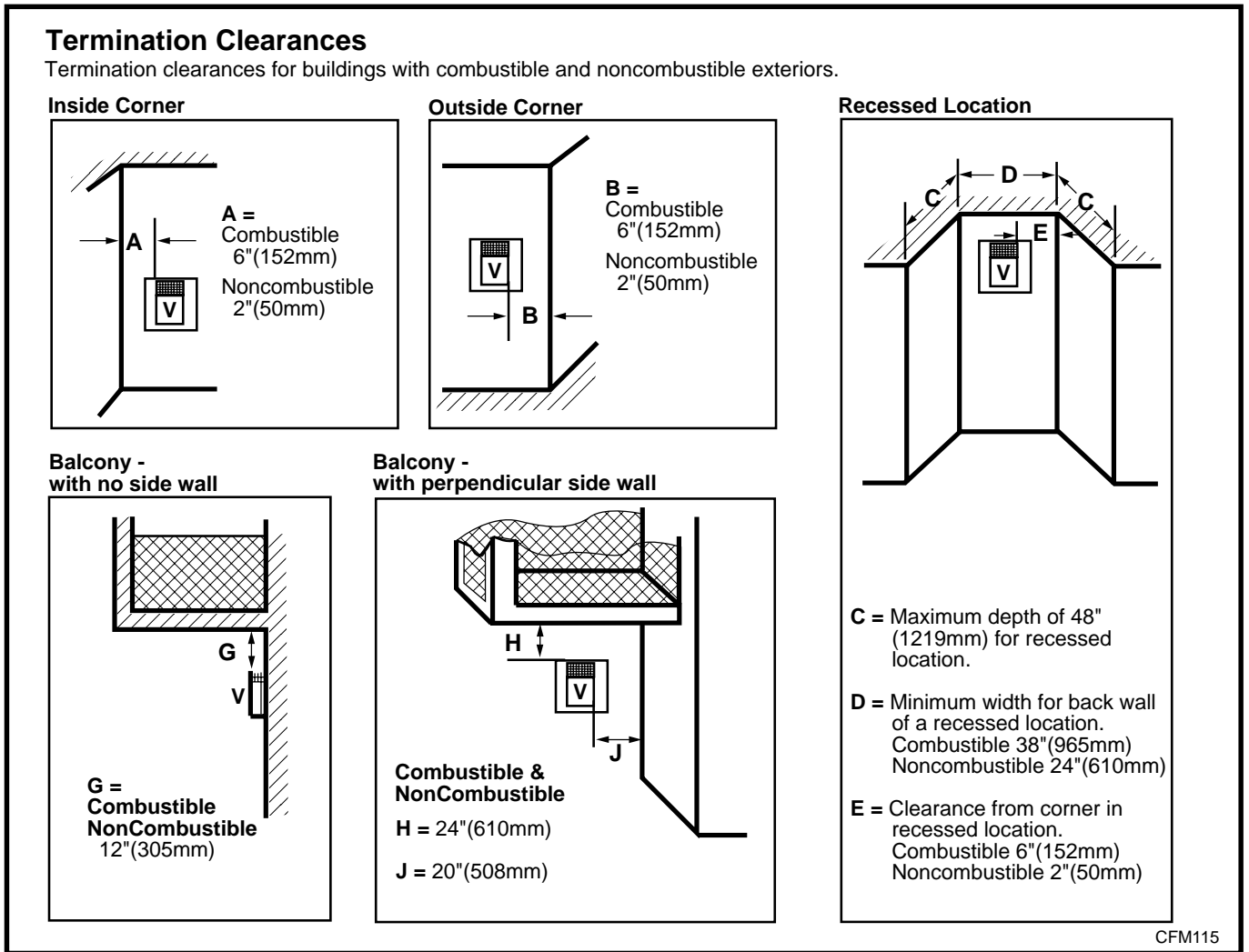

Fig. 12 Termination clearances.

General Information for Connecting Vent Pipes

Crimped End Pipes

Before joining elbows and pipes, apply a bead of high temperature sealant to the crimped end of the elbow or pipe.

Join the pipes using a 2" (50 mm) overlap and secure the joints with three sheet metal screws (Fig. 13). Wipe off excess sealant.

Canadian Installations:

The venting system must be installed in accordance with the current CSA-B149.1 installation code.

USA Installations:

The venting system must conform to local codes and/or the current National Fuel Code ANSI Z223.1.

Only venting components manufactured by Vermont Castings, Majestic Products may be used in Direct Vent systems.

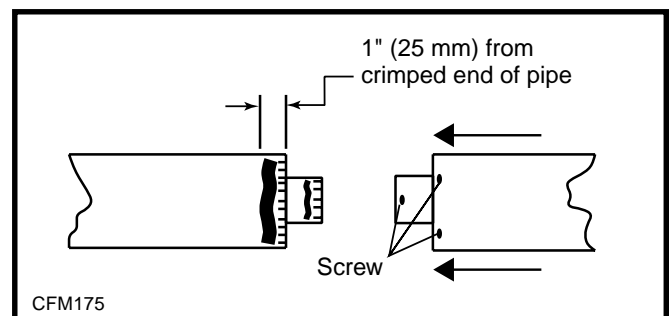

Fig. 13 Apply a bead of high temperature sealant.

Twist Lock Pipes

When using Vermont Castings, Majestic Products twist-lock pipe it is not necessary to use sealant on the joints. The only areas of the venting system that need to be sealed with high temperature silicone sealant are the collars on the fireplace and termination, and the sliding joint of any telescopic vent section used in the system.

To join twist lock pipes together, simply align the beads of the male end with the grooves of the female end, twisting the pipe until the flange on the female end contacts external flange on the male end. It is recommended that you secure the joints with three (3) sheet metal screws, however this is not mandatory with twist lock pipe (Fig. 14).

To make it easier to assemble the joints we suggest putting a lubricant (Vaseline or similar) on the male end of the twist lock pipe prior to assembly.

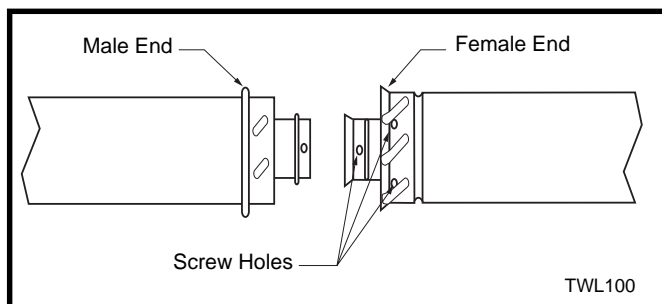

Fig. 14 Twist-Lock pipe joints.

Rear Wall Vent Application

When installed as a rear vent unit this appliance may be vented directly to a termination located on the rear wall behind the appliance

- Only Vermont Castings, Majestic Products venting components are approved to be used in these applications (See Venting Components listed for different installation requirements).
- The maximum horizontal distance between the rear of the appliance (or end of the transition elbow in a corner application) and the outside face of the rear wall is 20" (508 mm) (Fig. 15).
- Only one 45° elbow is allowed in these installations.
- The minimum clearances between any combustible material and the vent pipe sections are:

Top	2" (50 mm)
Sides	1" (25 mm)
Bottom	1" (25 mm)

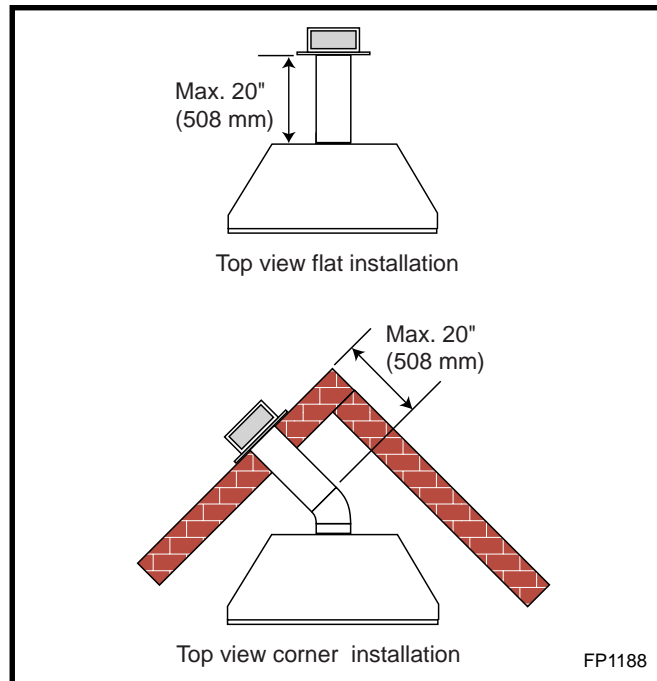

Fig. 15 Rear vent application, maximum horizontal distance.

Rear Wall Vent Installation

Step 1

Locate and cut the vent opening in the wall.

For combustible walls first frame in opening (Fig. 16).

Combustible Walls: Cut a 10³/₈"H x 9³/₈" W (265 mm x 240 mm) hole through the exterior wall and frame as shown.

Noncombustible Walls: Hole opening should be 7¹/₂" (190 mm) in diameter.



Zero clearance sleeve is only required for combustible walls.

Step 2

Measure wall thickness, and cut zero clearance sleeve to proper length; i.e., max. 12" (304.8 mm). Assemble sleeve to its maximum opening (10³/₈" x 9³/₈") and attach to firestop with #8 sheet metal screws (supplied). Install firestop assembly (Fig. 17).

Step 3

Measure the horizontal length requirement for the venting including a 2" (50 mm) overlap, i.e. from the elbow to the outside wall face plus 2" (50 mm) (Fig. 15).

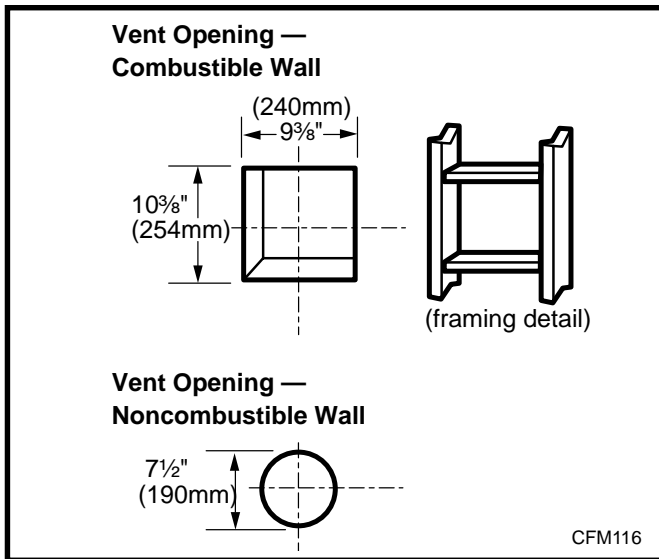

Fig. 16 Vent opening, side wall.

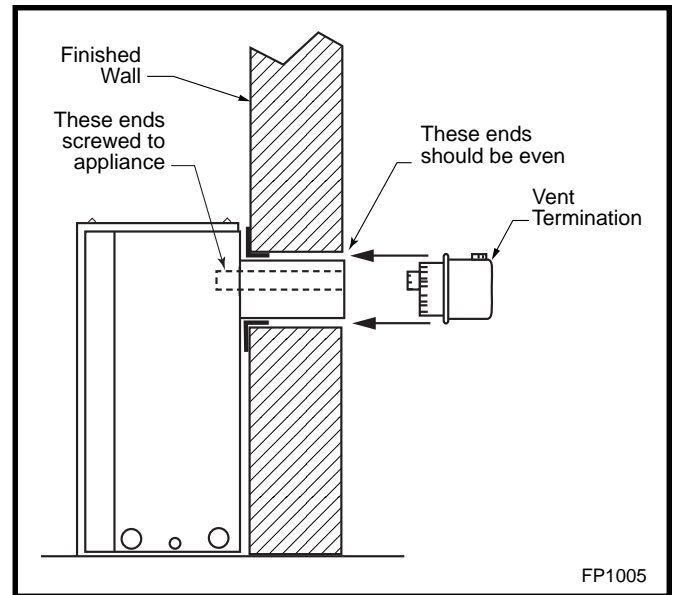

Fig. 18 Flat to the wall installation.

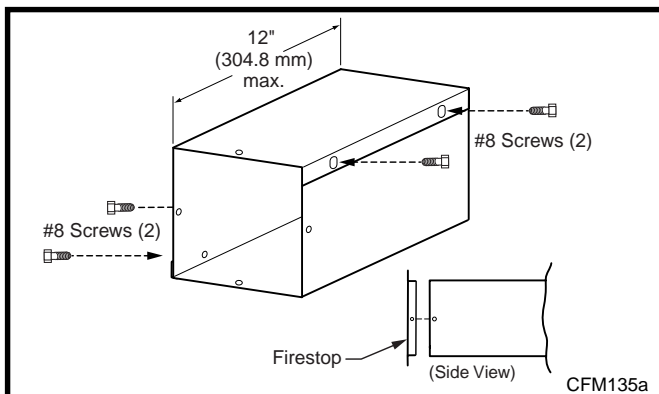

Fig. 17 Zero clearance sleeve.

Step 4

Install the 4" (100 mm) vent to the appliance collar and secure with 3 sheetmetal screws. Install the 7" (175 mm) vent pipe to the appliance collar and secure with 3 sheetmetal screws. It is not necessary to seal this connection. If a 45° elbow is being used attach the elbow to the appliance in the same manner then attach the venting to the elbow.



It is critical that there is no downward slope away from the appliance when connecting the vent or elbow.

Step 5

Guide the venting through the vent hole as you place the appliance in its installed position. Guide the 4" (100 mm) and 7" (175 mm) collars of the vent termination into the outer ends of the venting. Do not force the termination. If the vent pipes do not align with the termination remove and realign the venting at the appliance flue collars (Fig. 18). Attach the termination to the wall as outlined in the instruction sheet supplied with the termination.

How To Use the Vent Graph

The Vent Graph should be read in conjunction with the following vent installation instructions to determine the relationship between the vertical and horizontal dimensions of the vent system.

1. Determine the height of the center of the horizontal vent pipe exiting through the outer wall. Using this dimension on the Sidewall Vent Graph (Fig. 19), locate the point intersecting with the slanted graph line.
2. From the point of this intersection, draw a vertical line to the bottom of the graph.
3. Select the indicated dimension, and position the fireplace in accordance with same.

Example A:

If the vertical dimension from the floor of the fireplace is 11' (3.4 m) the horizontal run to the face of the outer wall must not exceed 14' (4.3 m)

Example B:

If the vertical dimension from the floor of the unit is 7' (2.14 m) the horizontal run to the face of the outer wall must not exceed 8½' (2.6 m)

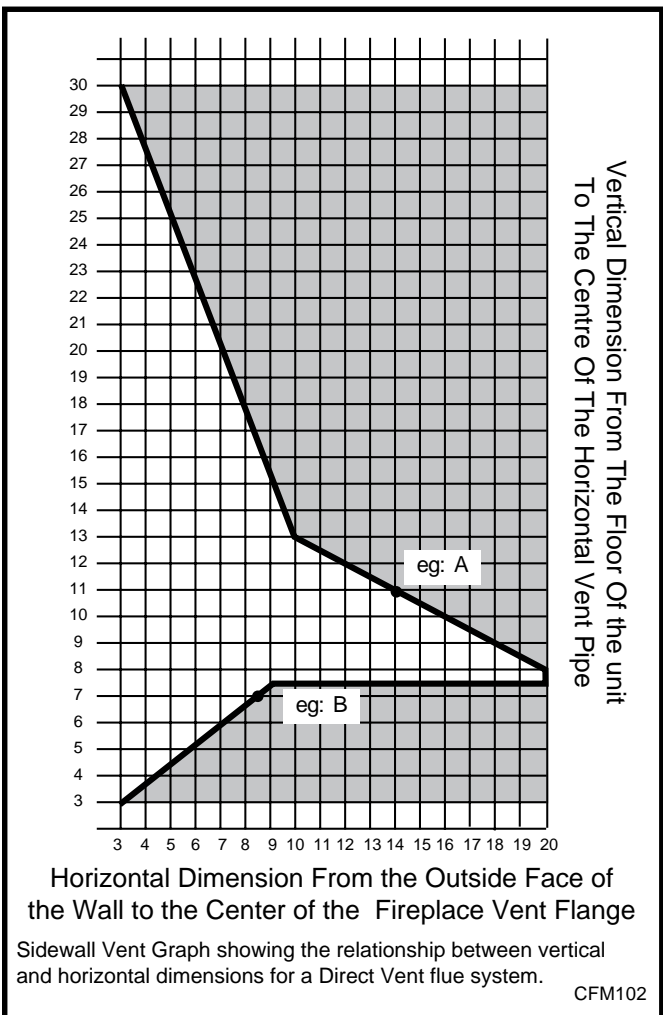

Fig. 19 Sidewall venting graph. (Dimensions in feet.)

Vertical Sidewall Application

Since it is very important that the venting system maintain its balance between the combustion air intake and the flue gas exhaust, certain limitations as to vent configurations apply and must be strictly adhered to.

The Vent Graph, showing the relationship between vertical and horizontal side wall venting, will help to determine the various dimensions allowable.

Minimum clearance between vent pipes and combustible materials is one 1" (25 mm) on top, bottom and sides unless otherwise noted.

When vent termination exits through foundations less than 20" (508 mm) below siding outcrop, the vent pipe must flush up with the siding.

It is best to locate the fireplace a way that minimizes the number of offsets and horizontal vent length.

The horizontal vent run refers to the total length of vent pipe from the flue collar of the fireplace (or the top of the Transition Elbow) to the face of the outer wall.

Horizontal plane means no vertical rise exists on this portion of the vent assembly.

When installing the appliance as a rear vent unit, the 90° or 45° transition elbow attached directly to the rear of the unit is NOT INCLUDED in the following criteria and calculations. Unless this transition elbow is specifically mentioned, it should be ignored when calculating venting layouts.

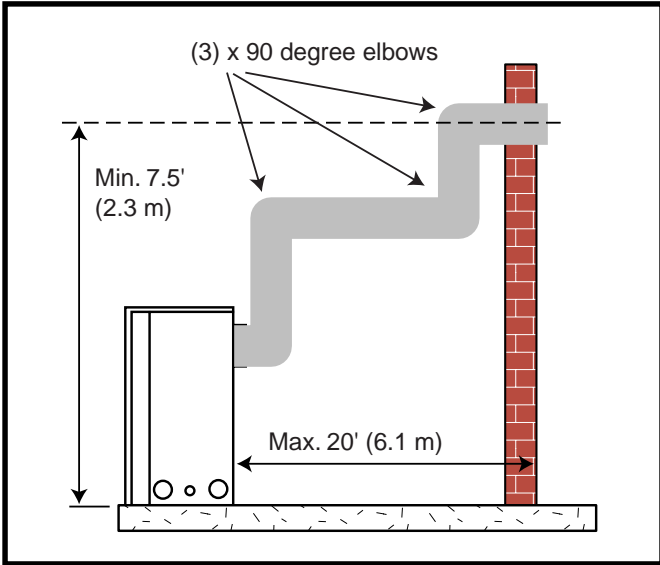

Fig. 20 Maximum three (3) 90° elbows per installation.

- The maximum number of 90° elbows per side wall installation is three (3) (Fig. 20).

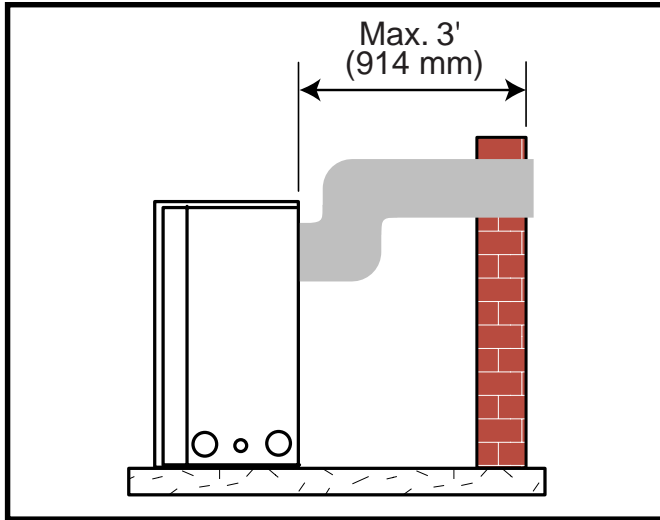

Fig. 21 Maximum horizontal run with no rise.

- If a 90° elbow is used in the horizontal vent run (level height maintained), the maximum horizontal vent length is reduced by 36" (914 mm) (Fig. 22). This does not apply if the 90° elbows are used to increase or redirect a vertical rise (Fig. 20).

Example: According to the vent graph (page 14), the maximum horizontal vent length in a system with a 7.5' (2.3 mm) vertical rise is 20' (6 m), and if a 90° elbow is required in the horizontal vent, it must be reduced to 17' (5.2 m).

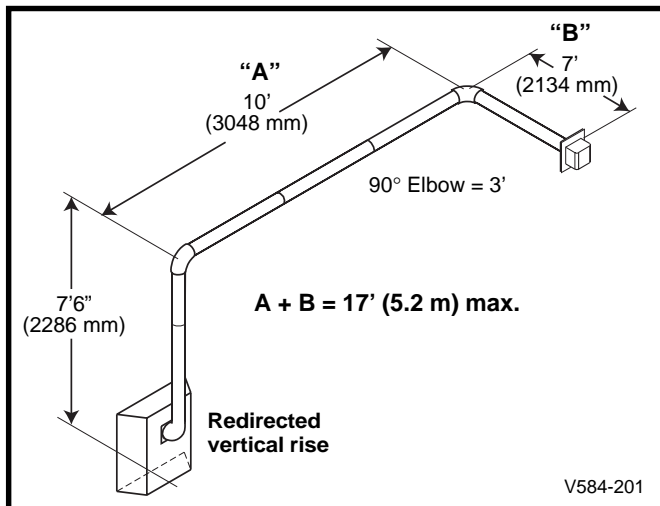

Fig. 22 Maximum vent run with elbows.

As shown in Fig. 22, the total of dimension A and B is not to be greater than 17' (5.2 m).

- The maximum number of 45° elbows permitted per side wall installation is two (2). These elbows can be installed in either the vertical or horizontal run.
- For each 45° elbow installed in the horizontal run, the length of the horizontal run MUST be reduced by 18" (45 cm). This does not apply if the 45° elbows are installed on the vertical part of the vent system.
- The maximum number of elbow degrees in a system is 270° (Fig. 23).

Example:

Elbow 1	=	90°
Elbow 2	=	45°
Elbow 3	=	45°
Elbow 4	=	90°

Total angular variation = 270°

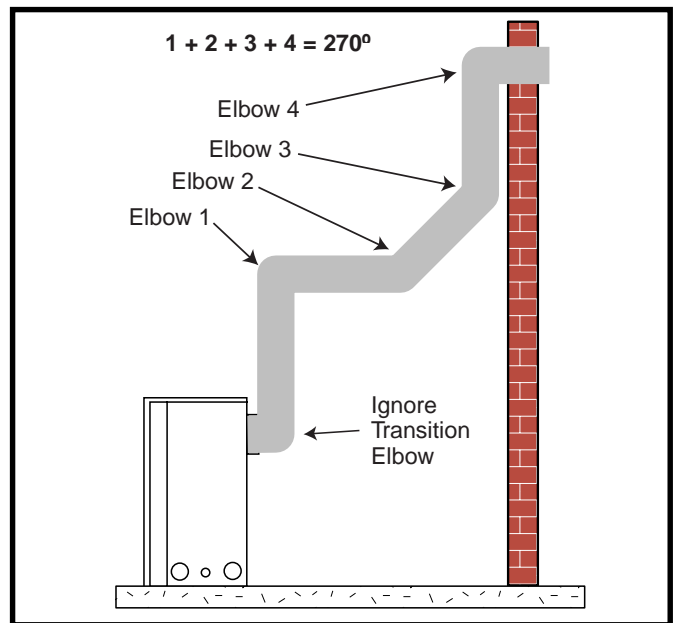

Fig. 23 Maximum elbow usage.

Vertical Sidewall Installation

Step 1

Locate vent opening on the wall. It may be necessary to first position the fireplace and measure to obtain hole location. Depending on whether the wall is combustible or noncombustible, cut opening to size. (For combustible walls, frame in opening first (Fig. 24).

Combustible Walls: Cut a $9\frac{3}{8}"$ H x $9\frac{3}{8}"$ W (240 mm x 240 mm) hole through the exterior wall and frame.

Noncombustible Walls: Hole opening must be $7\frac{1}{2}"$ (190 mm) in diameter.

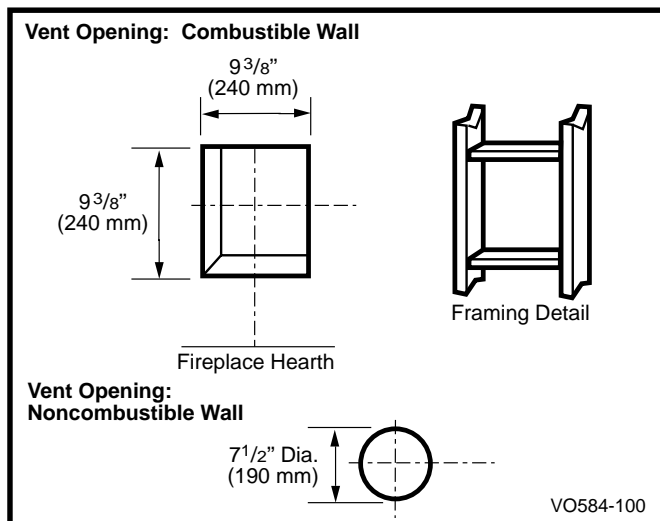

Fig. 24 Locate vent opening on wall.

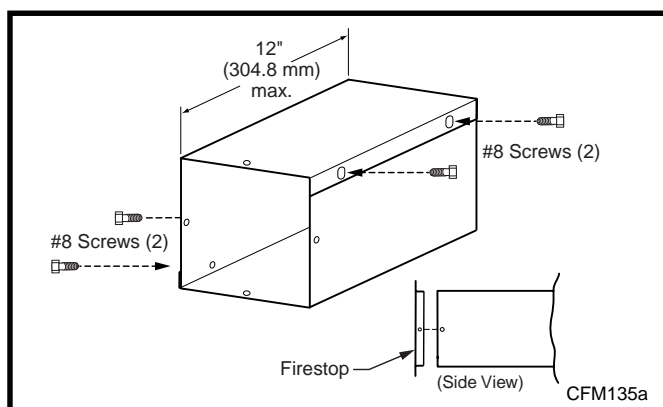

Fig. 25 Adjustable zero clearance sleeve.



Zero clearance sleeve is required only for combustible walls.

Step 2

Measure wall thickness and cut zero clearance sleeve parts to proper length (12" [305 mm] max.). Assemble sleeve and attach to firestop with #8 sheetmetal screws (supplied). Install firestop assembly (Fig. 25).

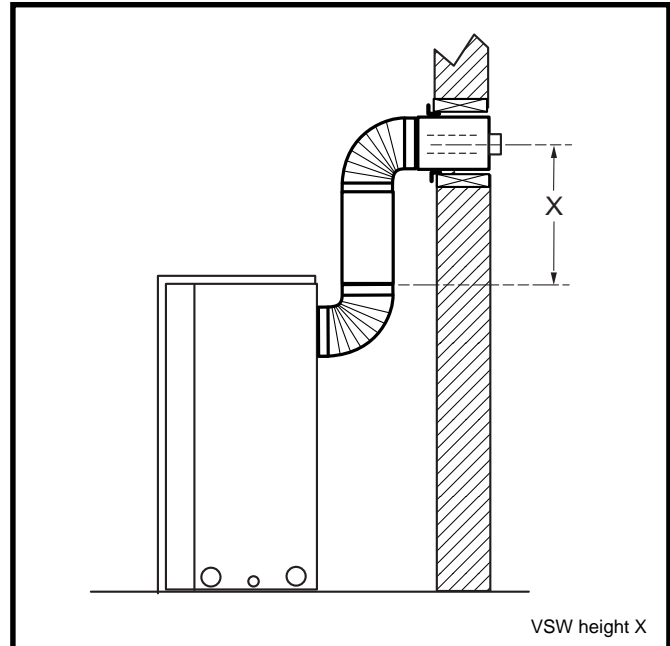

Fig. 26 Vertical height requirements.

Step 3

Place fireplace into position. Measure the vertical height (X) required from the base of the flue collars to the center of the wall opening (Fig. 26).

Step 4

Apply a bead of high temperature silicone sealant to the inner and outer flue collars of the fireplace and using appropriate length of pipe section(s) attach to fireplace with three (3) screws. Follow with the installation of the inner and outer elbow, again secure joints as described in the 'Connecting Vent Pipe' section.

Step 5

Measure the horizontal length requirement including a 2" (50 mm) overlap, i.e. from the elbow to the outside wall face plus 2" (50 mm)—or the distance required if installing a second 90° elbow (Fig. 27).



Always install horizontal venting on a level plane.

Step 6

Use the appropriate length of pipe sections—telescopic or fixed—and install. The sections which go through the wall are packaged with the starter kit, and can be cut to suit if necessary.

NOTE: Sealing vent pipe and firestop gaps with high temperature sealant will restrict cold air being drawn in around fireplace.

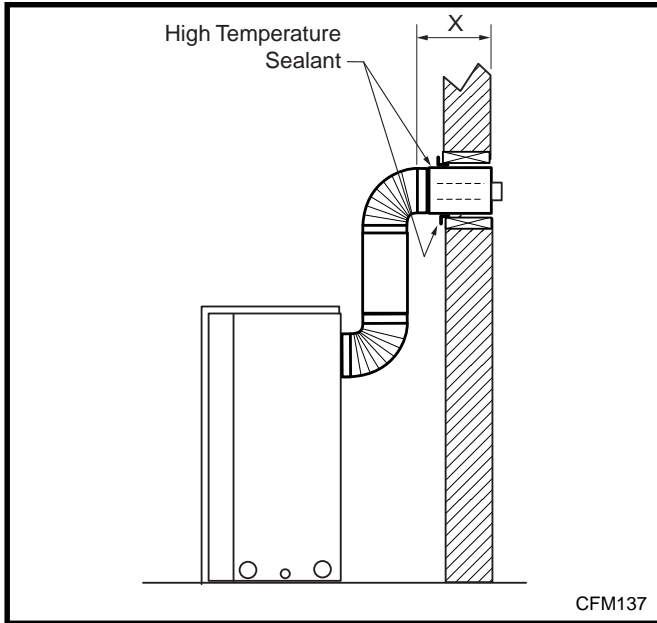

Fig. 27 Horizontal length requirement.

Step 7

Apply high temperature sealant to 4" (100 mm) and 7" (175 mm) collars or the termination one inch away from crimped end. Guide the vent terminations 4" and 7" collars into their respective vent pipes. Double check that the vent pipes overlap the collars by 2" (50 mm).

Secure the termination to the wall with screws provided and caulk around the wall plate to weatherproof.

As an alternative to screwing the termination directly to the wall, you may also use expanding plugs or an approved exterior construction adhesive. Or, you may attach the termination with screws through the inner body into the 4" vent pipe—however, for this method, you must extend the 4" pipe approximately 6" (150 mm) beyond the outer face of the wall.



Support horizontal pipes every 3' (91 cm) with metal pipe straps.

Below Grade Installation

When it is not possible to meet the required vent terminal clearances of 12" (305 mm) above grade level, a Snorkel Vent Kit #7DVSKS is recommended. It allows installation depth down to 7" (178 mm) below grade level. The 7" (178 mm) is measured from the center of the horizontal vent pipe as it penetrates through the wall.

NOTE: Ensure that sidewall venting clearances are observed. If the venting system is installed below ground, we recommend a window well with adequate and proper drainage to be installed around the termination area.

If installing a snorkel, a minimum 24" (610 mm) vertical rise is necessary. The maximum horizontal run with the 24" (610 mm) vertical pipe is 36" (915 mm). This measurement is taken from the collar of the fireplace (or transition elbow) to the face of the exterior wall. See the Sidewall Venting Graph for extended horizontal run if the vertical exceeds 24" (610 mm).

1. Establish vent hole through the wall (Fig. 24, page 16).
2. Remove soil to a depth of approximately 16" (406 mm) below base of snorkel. Install drain pipe. Install window well (not supplied). Refill hole with 12" (305 mm) of coarse gravel leaving a clearance of approximately 4" (100 mm) below snorkel (Fig. 28).
3. Install vent system.
4. Ensure a watertight seal is made around the vent pipe coming through the wall.
5. Apply high temperature sealant caulking (supplied) around the 4" and 7" snorkel collars.
6. Slide the snorkel into the vent pipes and secure to the wall.
7. Level the soil so as to maintain a 4" clearance (100 mm) below snorkel (Fig. 28).

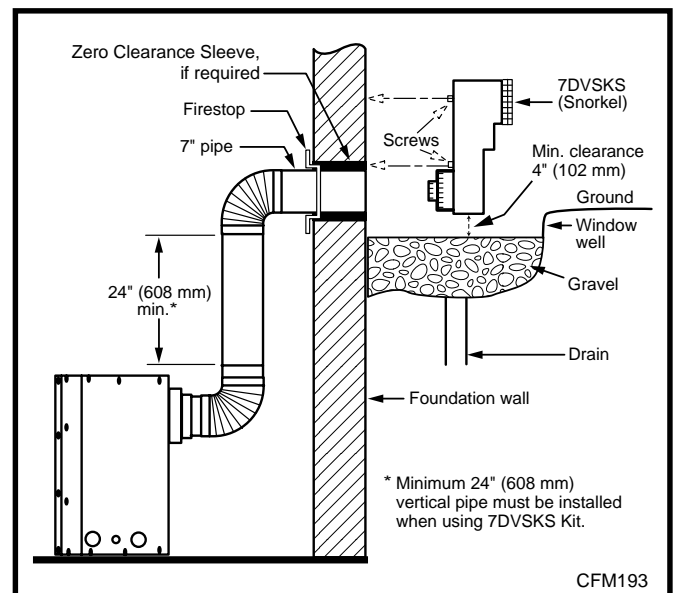

Fig. 28 Below grade installation.



Do not backfill around snorkel. A clearance of at least 4" (102 mm) must be maintained between the snorkel and the soil.

If the foundation is recessed, use recess brackets (not supplied) for securing lower portion of the snorkel.

Fasten brackets to wall first, then secure to snorkel with self drilling #8 x 1/2 sheet metal screws. It will be necessary to extend vent pipes out as far as the protruding wall face (Fig. 29).

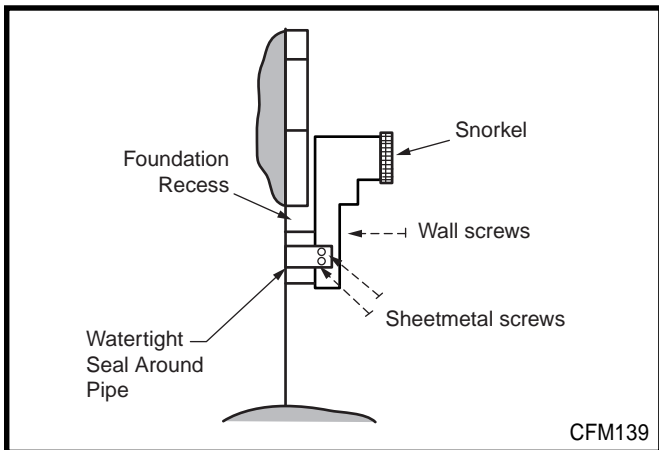

Fig. 29 Snorkel installation, recessed foundation.

Vertical Through-the-Roof Applications

This Gas Fireplace has been approved for,

- Vertical installations up to 40' (12 m) in height. Up to a 10' (3 m) horizontal vent run can be installed within the vent system using a maximum of two 90° elbows (Fig. 30).

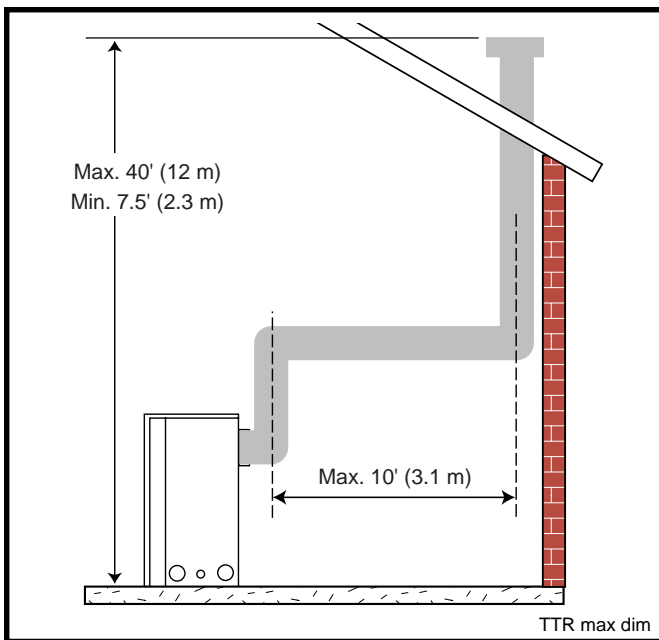

Fig. 30 Support straps for horizontal runs.

- Up to two 45° elbows may be used within the horizontal run. For each 45° elbow used on the horizontal plane, the maximum horizontal length must be reduced by 18" (450 mm).

Example: Maximum horizontal length

- No elbows = 10' (3 m)
- 1 x 45° elbows = 8.5' (2.6 m)
- 2 x 45° elbows = 7' (2.1 m)

- A minimum of an 8' (2.5 m) vertical rise is required.
- Two sets of 45° elbows offsets may be used within the vertical sections. From 0 to a maximum of 8' (2.5 m) of vent pipe can be used between elbows (Fig. 30).
- 7DVCS supports offsets (Fig. 32). This application will require that you first determine the roof pitch and use the appropriate starter kit. (See Venting Components List).
- The maximum angular variation allowed in the system is 270° (Fig. 31).
- The minimum height of the vent above the highest point of penetration through the roof is 2' (610 mm) (Fig. 33).

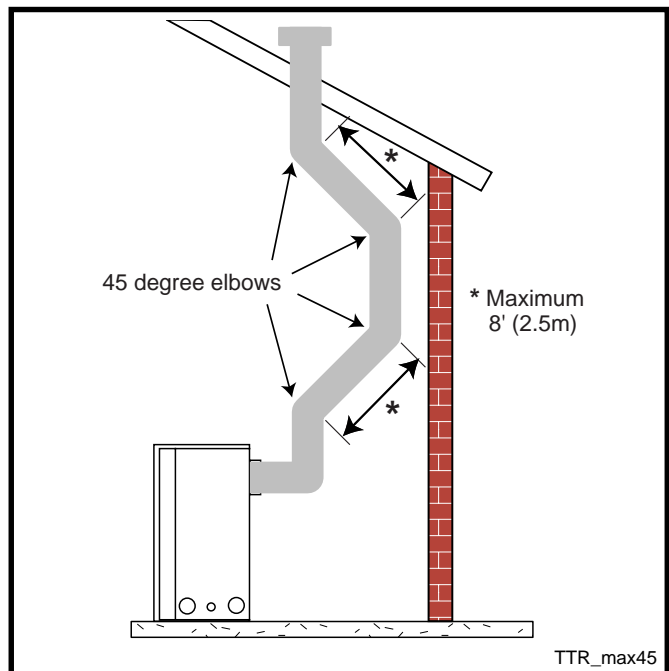

Fig. 31 Maximum elbow usage.

Vertical Through-the-Roof Installation

1. Locate your fireplace.
2. Plumb to center of the (4") flue collar from ceiling above and mark position.
3. Cut opening equal to $9\frac{3}{8}" \times 9\frac{3}{8}"$ (240 mm x 240 mm).
4. Proceed to plumb for additional openings through the roof. In all cases, the opening must provide a minimum of 1 inch clearance to the vent pipe, i.e., the hole must be at least $9\frac{3}{8}" \times 9\frac{3}{8}"$ (240 mm x 240 mm).
5. Place fireplace into position.
6. Place firestop(s) #7DVFS or Attic Insulation Shield #7DVAIS into position and secure (Fig. 32).
7. Install roof support (Fig. 33) and roof flashing, making sure upper flange is below the shingles (Fig. 34).
8. Install appropriate pipe sections until the venting is above the flashing (Fig. 34).
9. Install storm collar and seal around the pipe.
10. Add additional vent lengths for proper height (Fig. 33).
11. Apply high temperature sealant to 4" and 7" collars of vertical vent termination and install.



If a room is above ceiling level, a firestop spacer must be installed on each level (top and bottom) of the ceiling joists.
If an attic is above ceiling level, a 7DVAIS (Attic Insulation Shield) must be installed. Always face the enlarged ends of the vent section downward.

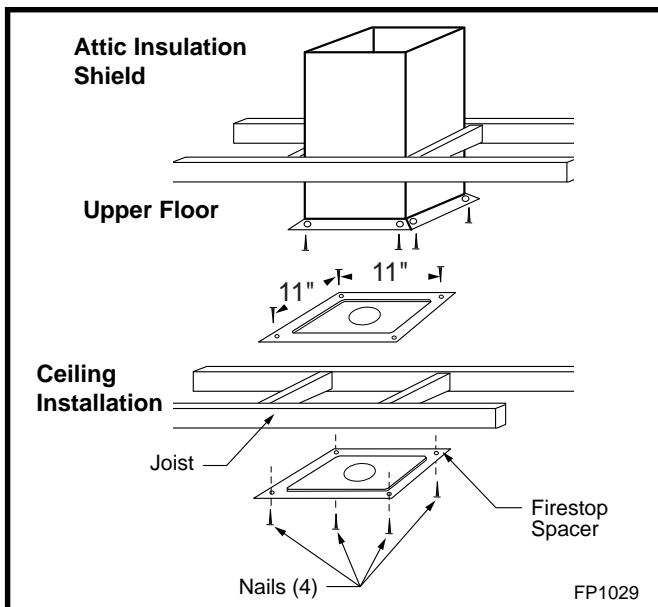

Fig. 32 Attic insulation shield and firestop spacer.

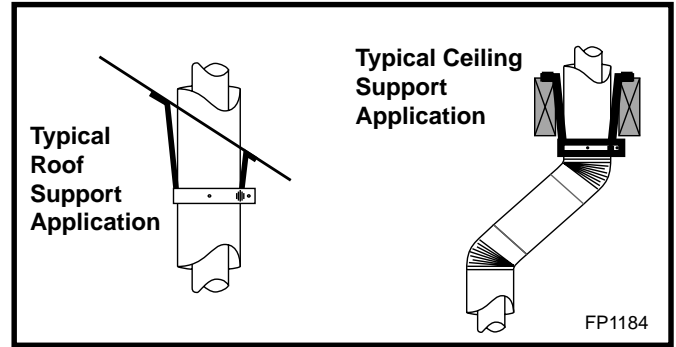

Fig. 32 Venting supports.

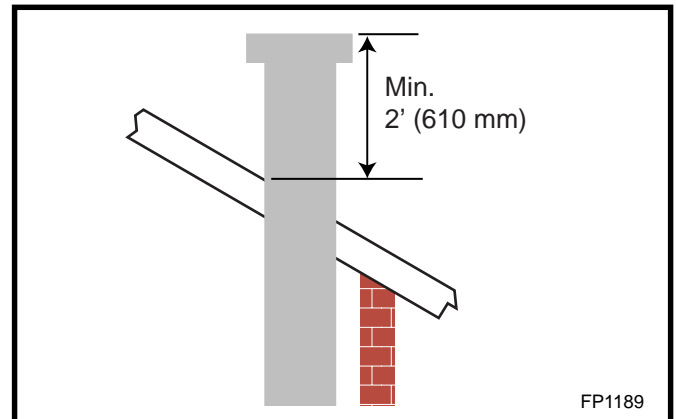

Fig. 33 Minimum termination to roof clearance.

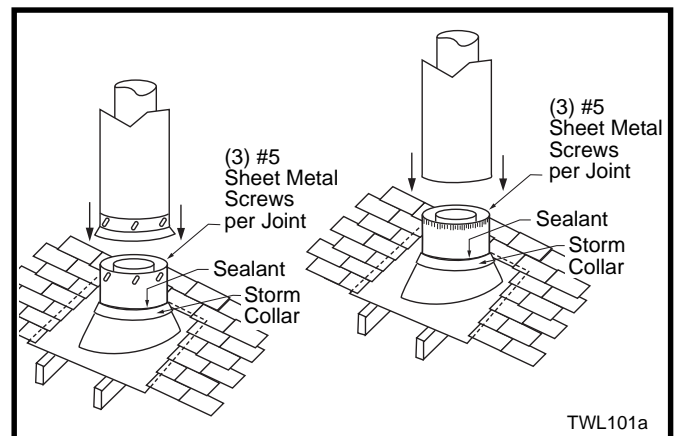

Fig. 34 Roof flashing.

DVR33 Bracket Restricter Installation

NOTES: When installing DVR33 with a vertical through-the-roof configured flue system, the bracket restricter supplied with the appliance (part# 10002910) should be fitted to the appliance at installation.

For DVR33 numbers A12H00, A12I00, A14A00 and A14B00 only, the restricter plate for the vertical termination (part# 10003246) must be installed for vertical runs over 20' (6.1 m).

Fitting the Bracket Restricter

1. Remove the window glass/frame assembly. Locate the baffle firebox assembly in the top rear of the firebox (Fig. 35).
2. Remove the four (4) nuts along the front edge, and the three (3) screws along the rear edge of the baffle assembly. Remove the baffle assembly from the firebox.
3. Remove the two (2) screws from the top face of the baffle assembly (Fig. 36). Place the bracket restricter as it is shown in Fig. 37, and secure it by refitting the screws.
4. Refit the baffle assembly to the firebox, replacing the three (3) screws and four (4) nuts.
5. Refit window glass/frame per the appropriate sections.

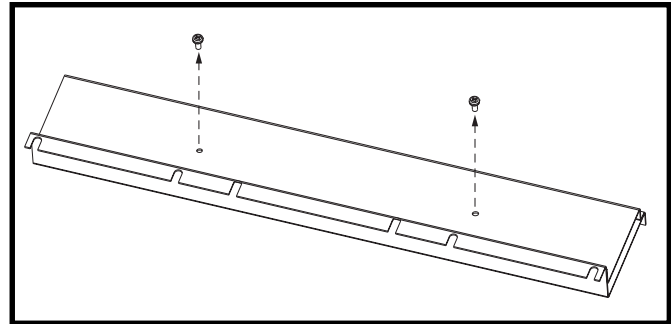

Fig. 36 Top face of baffle assembly

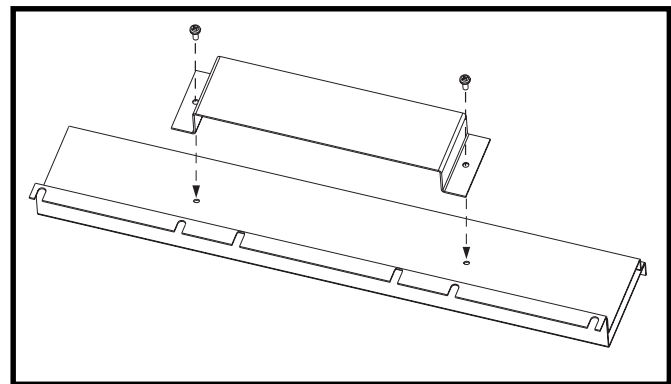

Fig. 37 Assembling bracket restricter to baffle assembly

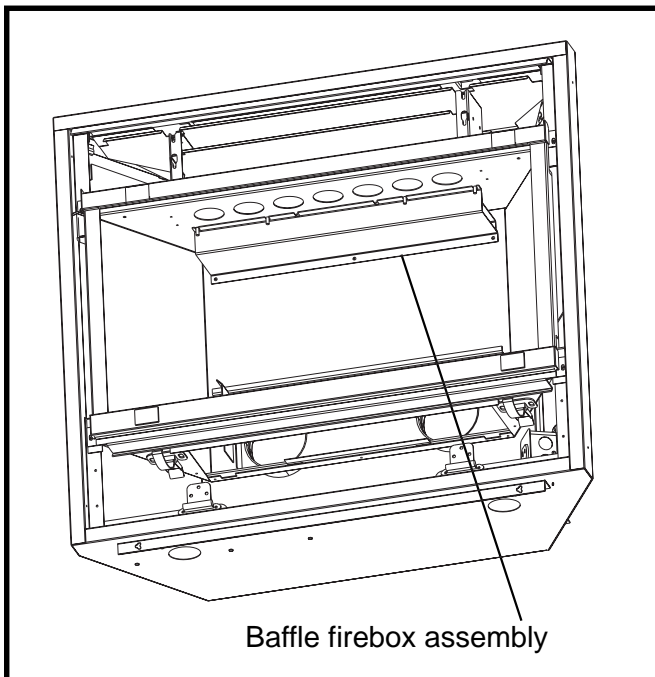
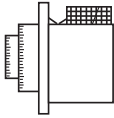
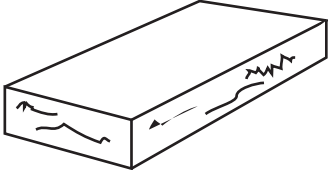
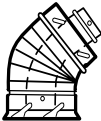
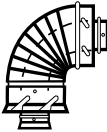
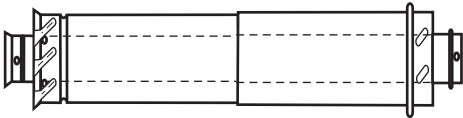

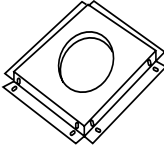
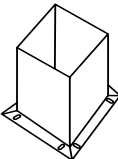
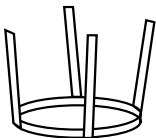
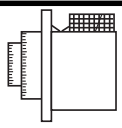
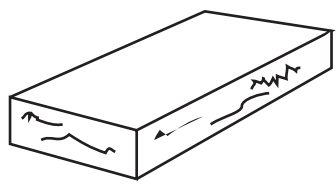
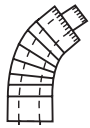
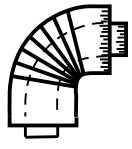
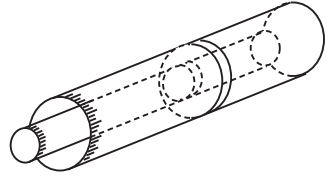
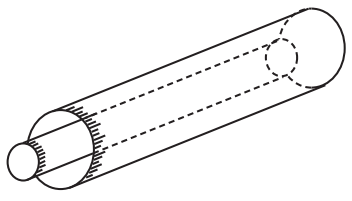
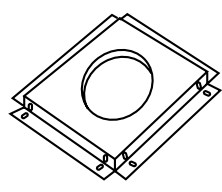
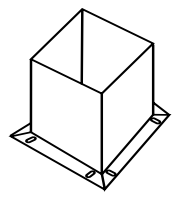
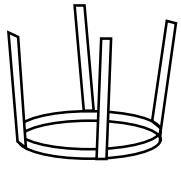

Fig. 35 Baffle firebox assembly

Twist Lock Venting Components

	<p>7DVRVT - Through-the-Wall Rear Vent Termination</p>
	<p>Starter Kit-Model 7TDVSK - Sidewall Venting Starter Kit-Model 7TDVSKV - Vertical Venting for 7TDVSKV-A order 1/12 to 6/12 roof pitch for 7TDVSKV-B order 7/12 to 12/12 roof pitch for 7TDSKV-F order flat roof Starter Kit-Model 7TDVSKS - Snorkel Kit for Below Grade Installation</p>
	<p>45° elbow kit 7TDVT45 for Vertical Installation Offsets 7TDR45 for Rear Vent Application</p>
	<p>90° Transition elbow kit 7TDVRT90 for Vertical Sidewall Applications or through-the-roof.</p>
	<p>Telescopic vent sections 7TDVP1218 -12" to 18" adjustable length 7TDVP3564 -35" to 64" adjustable length</p>
	<p>Pipe sections for vertical or horizontal venting Model 7TDVP8" 4 per box Model 7TDVP12" 4 per box Model 7TDVP24" 4 per box Model 7TDVP36" 4 per box Model 7TDVP48"</p>
	<p>Firestop Spacer Model 7DVFS</p>
	<p>Attic Insulation Shield Model 7DVAIS</p>
	<p>Vertical/Horizontal Combination Offset Support Model 7DVC</p>

Crimped End Venting Components

	<p>7DVRVT - Through the wall Rear Vent Termination</p>
	<p>Starter Kit-Model 7DVSK - Sidewall Venting Starter Kit-Model 7TDVSKV - Vertical Venting for 7DVSKV-A order 1/12 to 6/12 roof pitch for 7DVSKV-B order 7/12 to 12/12 roof pitch for 7DSKV-F order flat roof Starter Kit-Model 7TDVSKS-Snorkel Kit for Below Grade Installation</p>
	<p>45° elbow kit 7DVT45 for Vertical Installation Offsets 7DV45 for Rear Vent Application</p>
	<p>90° Transition elbow kit 7DVRT90 for Vertical Sidewall Applications or through-the-roof.</p>
	<p>Telescopic vent sections 7DVP610- 6" to 10" adjustable length 7DVP1018- 10" to 18" adjustable length 7DVP1834- 18" to 34" adjustable length 7DVP3466- 34" to 66" adjustable length</p>
	<p>Pipe sections for vertical or horizontal venting Model 7DVP8" 4 per box Model 7DVP12" 4 per box Model 7DVP24" 4 per box Model 7DVP36" Model 7DVP48"</p>
	<p>Firestop Spacer Model 7DVFS</p>
	<p>Attic Insulation Shield Model 7DVAIS</p>
	<p>Vertical/Horizontal Combination Offset Support Model 7DVCS</p>

Operating Instructions

Glass Information



Use only glass approved by Vermont Castings, Majestic Products on this fireplace.

- The use of any non-approved replacement glass will void all product warranties.
- Care must be taken to avoid breakage of the glass.
- Under no circumstances should this appliance be operated without the front glass in place, or with the glass in a damaged condition.
- Replacement glass (complete with gasket) is available through your Vermont Castings, Majestic Products dealer, and should only be installed by a licensed qualified service person.

Louvre Removal

To remove the louvre assembly top, lift the panel up and out from the fireplace (Fig. 38).

NOTE: The louvre assembly bottom is hinged at the bottom edge and swings down.

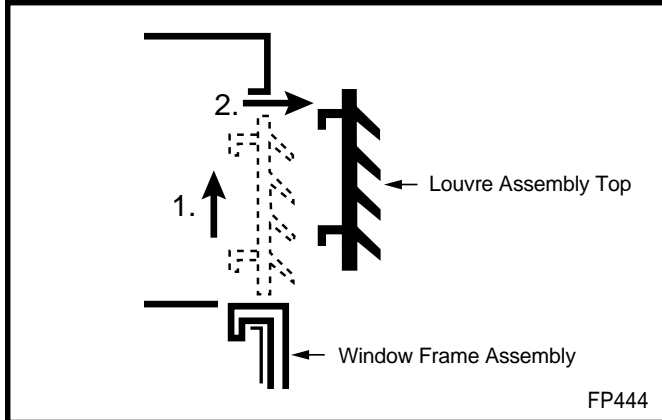

Fig. 38 Remove louvre assembly top.

Window Frame Assembly Removal

1. Turn the fireplace OFF (including the pilot).
2. If the unit has been operating, allow time for the components to cool.
3. Remove the louvre assembly top.
4. Open the louvre assembly bottom.
5. Release the two clamps along lower edge of the frame by pulling down on clamp handles (Fig. 39).

6. Tilt window frame assembly out slightly at the bottom, lift the frame up and away from the fireplace.
7. To replace window frame assembly, reverse this procedure.

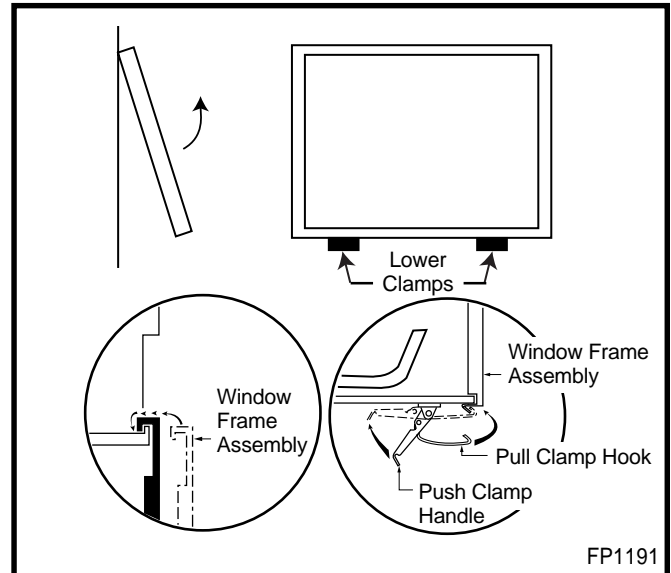

Fig. 39 Window frame assembly removal.

Glass Cleaning

It is necessary to periodically clean the glass panel.

During start-up, it is normal for condensation to form on the inside of the panel. This condensation causes lint, dust and other airborne particles to cling to the surface of the glass.

Also, initial paint curing may deposit a slight film on the glass. It is therefore recommended the glass panel be cleaned two or three times with a non-ammonia-based household cleaner and warm water within the first few weeks of operation. We recommend using gas fireplace glass cleaner.

After the initial cleaning process, clean the glass two or three times during each operating season, depending on the environment in the house.



Clean the glass after the first two weeks of operation.

Do not clean glass when it is hot.

Do not use abrasive cleaners.

Do not strike or slam the glass.

Installation of Logs and Lava Rock Material



The logs are fragile and should be handled with care.

Keep the packaging material out of the reach of children, and dispose of the material in a safe manner.

During this procedure, refer to Fig. 40 for log identification.

1. Remove the top louvre assembly.
2. Remove the window frame assembly. See "Window Frame Assembly Removal" on page 23.
3. Fit the rear right log (A34) in place on the rear log support. The hole in the underside of the log fits over the pin on the right end of the support shelf.
4. Fit the front/rear left log (A33) in place on the rear log support. The hole in the underside of the log fits over the pin on the left end of the support shelf.
5. Fit the front right log (A35) in place, the top end of the log with the hole in the underside aligning with the knob on the rear right log (A34), and the other end with the cut slot resting on the right side edge of the front grate.
6. Fit the front center log (A36) on the center slot of the front grate. The flat end of this log sets against the back wall of the front grate plate.

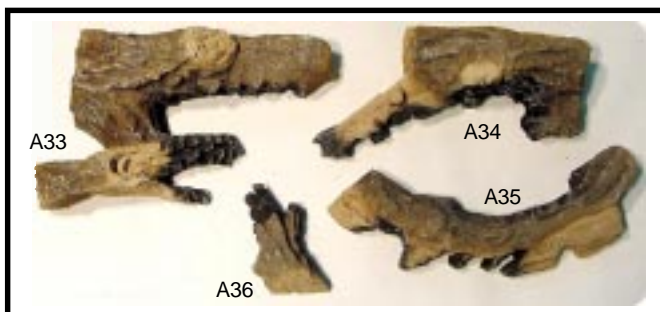

Fig. 40 DVR33 Log Set (top view)

The log set contains two types of lava rocks. Placing these materials is best done after the logs have been installed.

Glowing Lava Rock: (Part Number 57897) Remove from the packaging and spread them over the burner tiles in a random fashion to fill the space highlighted in Fig 41.

Lava Rock: (Part Number 10001454) Remove from packaging and spread over the sides of the burner housing. **Do not place this material on the burner tiles.**



Fig. 41 DVR33 Log Set Assembly.

NOTE: Glowing lava rock for DVR33 is only allowed to be positioned at the front area (radiant portion) of the burner housing assembly.

Flame and Temperature Adjustment

RN/RP and EN/EP Models

For units equipped with 'HI/LO' valves the flame adjustment is accomplished by rotating the 'HI/LO' adjustments knob located near the center of the gas control valve (Fig. 41 and Fig. 42).

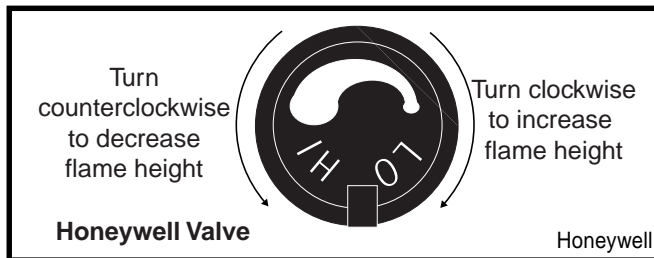

Fig. 41 Flame adjustment knob for Honeywell Valve.

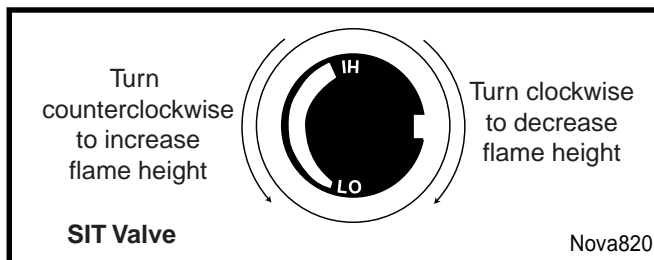

Fig. 42 Flame adjustment knob for SIT Valve.

Flame Characteristics

It is important to periodically perform a visual check of the pilot and burner flames. Compare them to the pictorials illustrated below (Fig. 43 and Fig. 44). If the flame patterns appear abnormal, contact a qualified service provider for service and adjustment.

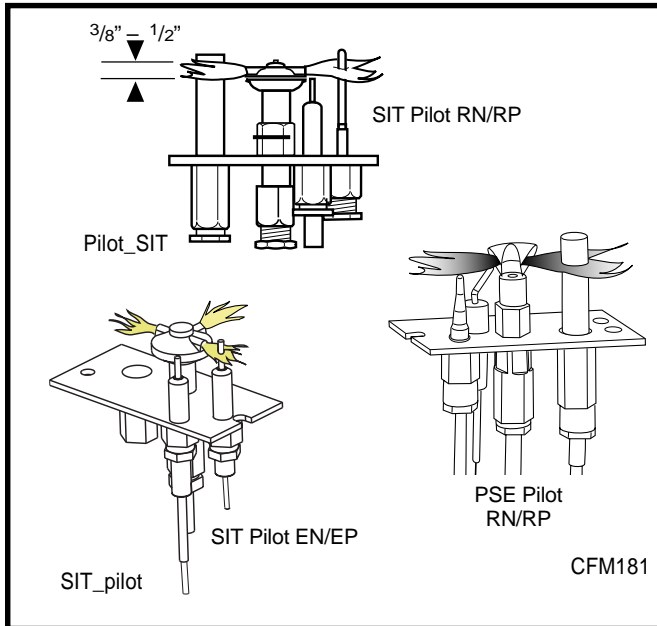

Fig. 43 Correct pilot flame appearance.



Fig. 44 Correct burner flame appearance.

Inspecting the Venting System

This appliance venting system is designed and constructed to develop a positive flow adequate to remove flow gases to the outside atmosphere.

Any foreign objects in the venting system, except those designed specifically for the venting system, may cause spillage of flue gases.

To inspect the venting system, make sure the main gas valve is off. Remove the window frame assembly (Refer to Window Frame Assembly Removal section). Using a flashlight, check the area above the baffle in the combustion dome. Clean if necessary.

Lighting and Operating Instructions

FOR YOUR SAFETY, READ BEFORE LIGHTING

WARNING: If you do not follow these instructions exactly, a fire or explosion may result causing property damage, personal injury or loss of life.

- A. This heater has a pilot which must be lit manually. When lighting the pilot follow these instructions exactly.
- B. BEFORE LIGHTING smell all around the heater area for gas. Be sure to smell next to the floor because some gas is heavier than air and will settle on the floor.

WHAT TO DO IF YOU SMELL GAS

- Do not try to light any fireplace.
- Do not touch any electric switch.
- Do not use any phone in your building.
- Immediately call your gas supplier from a neighbor's phone. Follow the gas supplier's instructions.

- If you cannot reach your gas supplier, call the Fire Department.

- C. Use only your hand to push in or turn the gas control knob. Never use tools. If the knob will not push in or turn by hand, do not try to repair it, call a qualified service technician. Applying force or any attempted repair may result in a fire or explosion.
- D. Do not use this fireplace if any part has been under water. Immediately call a qualified service technician to inspect the heater and to replace any part of the control system and any gas control which has been under water.

Lighting Instructions

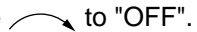
1. **STOP!** Read the safety information above.
2. Turn off all electrical power to the fireplace.
3. For MN/MP/TN/TP appliances ONLY, go on to Step 4. For RN/RP appliances turn the On/Off switch to "OFF" position or set thermostat to lowest level.
4. Open control access panel.
5. Push in gas control knob slightly and turn clockwise  to "OFF".

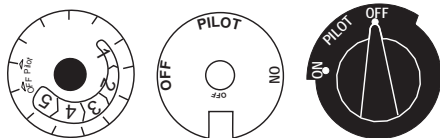

Euro SIT SIT NOVA Honeywell

6. Wait five (5) minutes to clear out any gas. Then smell for gas, including near the floor. If you smell gas, STOP! Follow "B" in the safety information above. If you do not smell gas, go to the next step.
7. Remove glass door before lighting pilot. (See Glass Frame Removal section).
8. Visibly locate pilot by the main burner.
9. Turn knob on gas control counter-clockwise  to "PILOT".

10. Push the control knob all the way in and hold. Immediately light the pilot by repeatedly depressing the piezo spark igniter until a flame appears. Continue to hold the control knob in for about one (1) minute after the pilot is lit. Release knob and it will pop back up. Pilot should remain lit. If it goes out, repeat steps 5 through 8.

- If knob does not pop up when released, stop and immediately call your service technician or gas supplier.

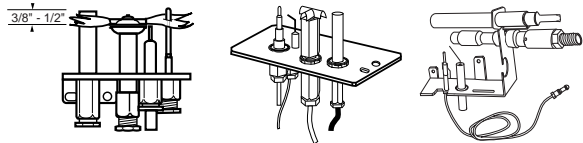

- If after several tries, the pilot will not stay lit, turn the gas control knob to "OFF" and call your service technician or gas supplier.
11. Replace glass door.
 12. Turn gas control knob to "ON" position.
 13. For RN/RP appliances turn the On/Off switch to "ON" position or set thermostat to desired setting.
 14. Turn on all electrical power to the fireplace.

To Turn Off Gas To Heater

1. Turn the On/Off switch to Off position or set the thermostat to lowest setting.
2. Turn off all electric power to the fireplace if service is to be performed.

3. Open louvre assembly bottom.
4. Push in gas control knob slightly and turn clockwise  to "OFF". Do not force.
5. Close control access panel.

Lighting and Operating Instructions

For Fireplaces equipped with SIT822 Gas Valve (EN or EP)

Warning: If you do not follow these instructions exactly, a fire or explosion may result causing property damage, personal injury and loss of life.

For your safety, read the following warnings before lighting the appliance:

- A. This fireplace is equipped with an ignition device which automatically lights the pilot. **DO NOT** try to light the pilot by hand.
- B. **BEFORE OPERATING**, smell all around the appliance area for gas. Be sure to smell next to the floor because some gas is heavier than the air and will settle on the floor.
What to do if you smell gas
 - **Do not try to light any appliance**
 - **Do not operate any electrical switch.**
 - **Do not use any phone in your building.**
 - **Immediately call your gas supplier from a neighbor's phone. Follow the gas suppliers instructions.**
- **If you cannot contact your gas supplier call the Fire Department**
- C. Use only your hand to push in or turn the gas control knob. Never use tools. If the knob will not push in or turn by hand do not try to repair it, call a qualified service technician. Force or attempting repair may result in a fire or explosion.
- D. Do not use this appliance if any part has been under water. Immediately call a qualified service technician to inspect the appliance and replace any part of the control system and any gas control that has been under water.

Lighting Instructions

1. **STOP!** Read the safety information above before continuing.
2. Turn off all electrical power to the appliance.
3. This appliance is equipped with an ignition device which automatically lights the pilot. **DO NOT try to light the pilot by hand.**
4. Access the gas control by lowering the lower access door (louvre assembly).
5. Turn the remote switch, if used, OFF. Turn the wireless remote, if used, OFF.
6. Wait five (5) minutes to clear out any gas. Then smell for gas, including near the floor. If you smell gas **STOP**. Follow instructions B in the safety warnings above. If you do not smell gas go onto the next step.
7. Close the access door.
8. Turn ON all electrical power to the appliance.
9. Turn remote switch or wireless remote to ON.
10. If the appliance will not operate, follow the instructions "Turning Off the Gas to the Appliance" (below), and call your service technician or gas supplier.

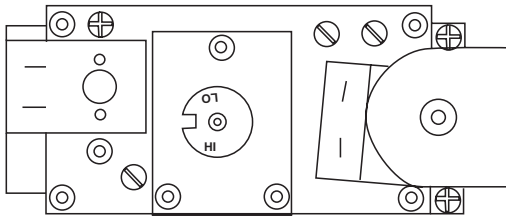

Turning Off the Gas to the Appliance

1. Turn the remote switch to the "OFF" position.
2. Turn OFF all electrical power to the fireplace if service is required.
3. Open the lower access panel.
4. Turn the shut-off valve on the flexible gas line to the "OFF" position.

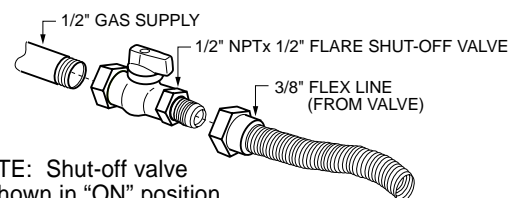

NOTE: Shut-off valve is shown in "ON" position

Troubleshooting – Honeywell Millivolt Valve



Window Frame Assembly Should be Removed Before Service Work

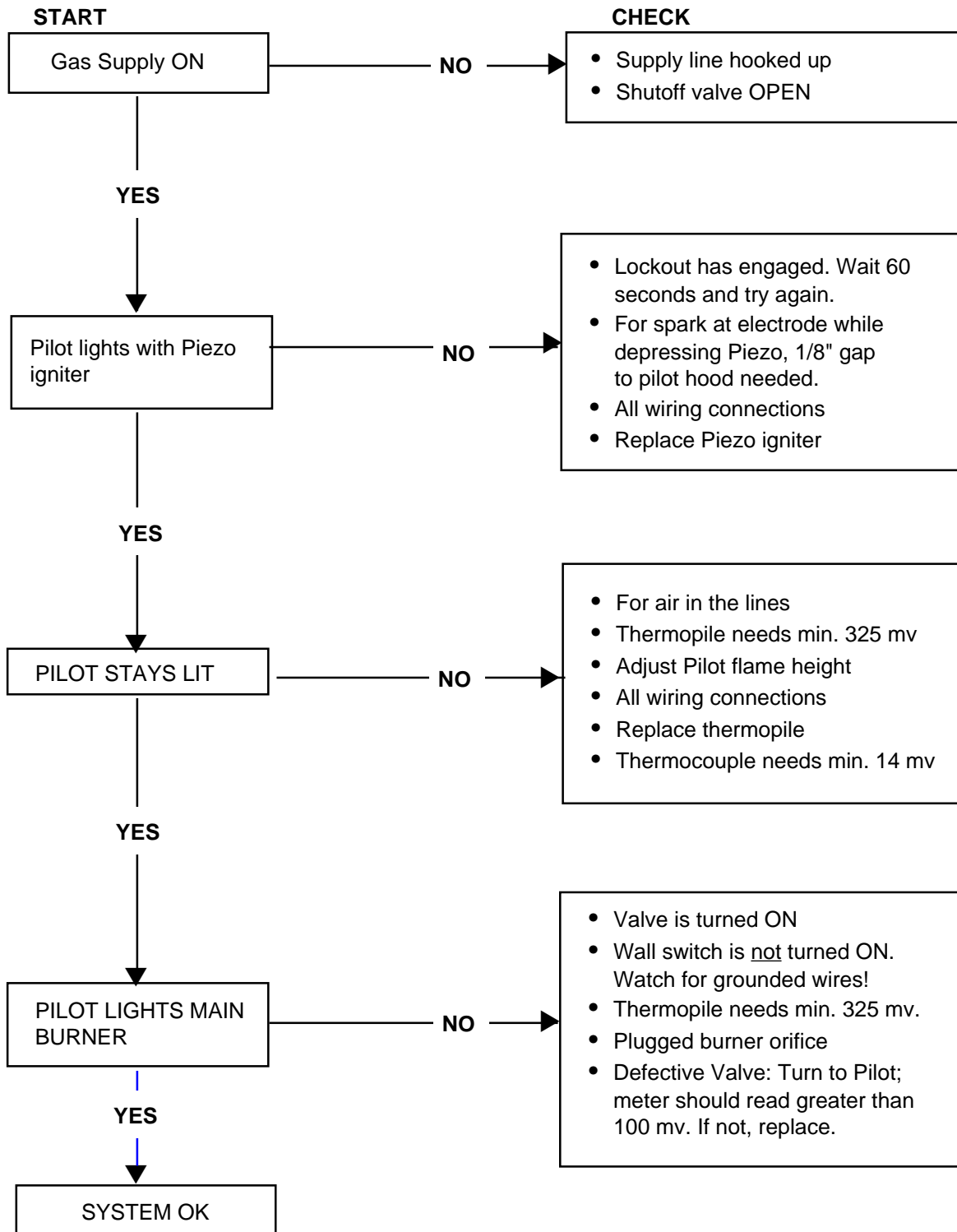

Troubleshooting the Gas Control System

SIT NOVA 820 MILLIVOLT VALVE

Note: Before trouble shooting the gas control system, be sure external gas shut off is in the “On” position.

WARNING: BEFORE DOING ANY GAS CONTROL SERVICE WORK, REMOVE GLASS FRONT.

SYMPTOM	POSSIBLE CAUSES	CORRECTIVE ACTION
1. Spark ignitor will not light	A. Defective or misaligned electrode at pilot.	Using a match, light pilot. If pilot lights, turn off pilot and push the red button again. If pilot does not light, check gap at electrode and pilot; it should be 1/8" to have a strong spark.
	B. Defective ignitor (Push Button)	Push Piezo Ignitor Button. Check for spark at electrode and pilot. If no spark to pilot, and electrode wire is properly connected, replace ignitor.
2. Pilot will not stay lit after carefully following lighting instructions.	A. Defective pilot generator (thermocouple), remote wall switch.	Check pilot flame. Must impinge on thermocouple/thermopile. Note: this pilot burner assembly utilizes both a thermocouple and a thermopile. The thermocouple operates the main valve operation (On and Off). Clean and or adjust pilot for maximum flame impingement on thermopile and thermocouple.
	B. Defective automatic valve	Turn valve knob to “Pilot”. Maintain flow to pilot; millivolt meter should read greater than 10 mV. If the reading is okay and the pilot does not stay on, replace the gas valve. Note: An interrupter block (not supplied) must be used to conduct this test.
3. Pilot burning, no gas to main burner	A. Wall switch or wires defective	Check wall switch and wires for proper connections. Jumper wire across terminals at wall switch, if burner comes on, replace defective wall switch. If okay, jumper wires across wall switch wires at valve, if burner comes on, wires are faulty or connections are bad.
	B. Thermopile may not be generating sufficient millivoltage.	<ol style="list-style-type: none"> 1. Be sure wire connections from thermopile at gas valve terminals are tight and thermopile is fully inserted into pilot bracket. 2. One of the wall switch wires may be grounded. Remove wall switch wires from valve terminals if pilot now stays lit, trace wall switch wiring for ground. May be grounded to fireplace or gas supply. 3. Check thermopile with millivolt meter. Take reading at thermopile terminals of gas valve. Should read 250-300 millivolts (minimum 150) while holding valve knob depressed in pilot position and wall switch “Off”. Replace faulty thermopile if reading is below specified minimum.
	C. Plugged burner orifice.	Check burner orifices for debris and remove.
	D. Defective automatic valve operator.	Turn valve knob to “On”, place wall switch to “On” millivolt meter should read greater than 100 mV. If the reading is okay and the burner does not come on, replace the gas valve.
4. Frequent pilot outage problem.	A. Pilot flame may be too low or blowing (high) causing the pilot safety to drop out.	Clean and/or adjust pilot flame for maximum flame impingement on thermopile and thermocouple.
	B. Possible blockage of the vent terminal.	Check the vent terminal for blockage (recycling the flue gases)

Troubleshooting the Gas Control System

SIT 822 Valve with a Honeywell Electronic Igniter

NOTE: Remove glass before servicing.

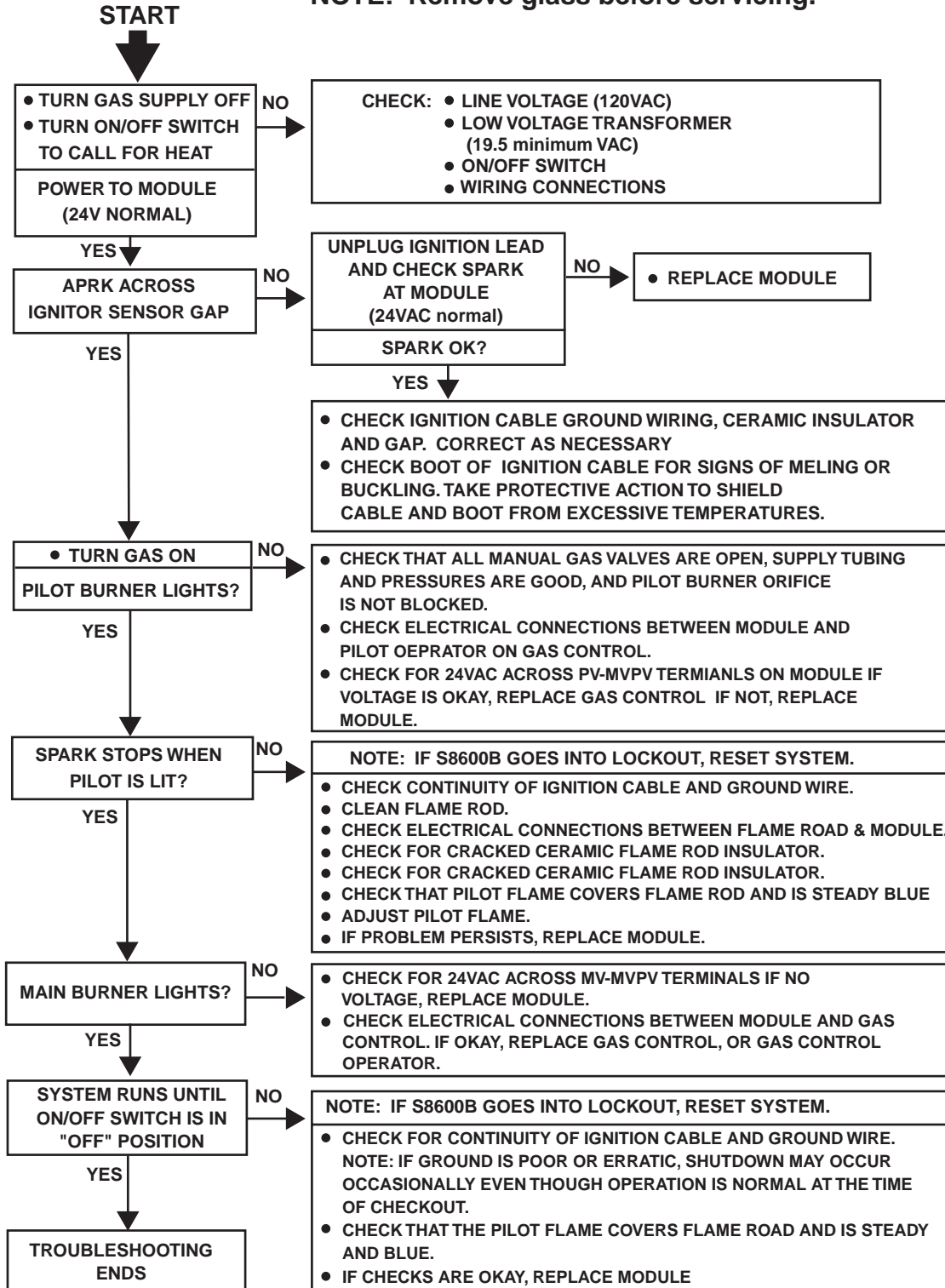

Fuel Conversion Instructions

For RN and RP models only:



The conversion of this appliance from one gas to another must be carried out by an authorized service provider.

1. Disconnect power to unit and shut off the gas supply.
2. Remove the glass (see "Window Frame Assembly Removal" section).
3. Carefully remove the logs and lava rock material.
4. Remove the pilot assembly from the bracket.
5. Remove the screws that are holding the burner housing assembly in place.
6. Remove the burner housing assembly.
7. Remove front and rear orifice and replace with the orifice supplied in the conversion kit. Use the orifice with the smallest hole for the front burner and the orifice with the largest hole for the rear burner.

NOTE: On the DVRT43 (only), the adjustable air shutter on the end burner housing must be replaced. Refer to the instructions in the specific gas conversion kit for details.

8. SIT Top Convertible Pilot

Gently lift off pilot hood from the pilot. (Do not remove the spring clip holding the hood in place). Using a 5/32" Allen key, unscrew the exposed orifice. Insert the new orifice supplied in the kit, do not over tighten the orifice. Replace the pilot hood ensuring the index tab aligns with the notch on the hood.

PSE Pilot

Using a suitable wrench on the hexagonal body unscrew the pilot hood assembly from the pilot; **do not twist the hood itself**. Remove the orifice and replace it with the new orifice supplied in the kit. Refit the pilot hood assembly. **Do not overtighten the pilot hood. The hood must return to its original alignment. Take care to not damage the thermocouple, thermopile, or igniter.**

9. SIT 820 NOVA Gas Control Valve (Fig. 47):

- a) Using a Torx T20 or slotted screwdriver, remove and save three (3) pressure regulator mounting screws (A), pressure regulator tower (B), and diaphragm (C).
- b) Ensure the rubber gasket (D) is properly positioned and install the new Hi/Lo pressure regulator to valve, using the new screws (E) supplied with the kit. Tighten screws securely. (Reference torque: 25 in.lb)
- c) Install the enclosed identification label (F) to the valve body where it can be easily seen.

Honeywell Gas Control Valve (Fig. 48):

The Honeywell valve fitted to this unit is suitable for use with LP or Natural Gas. It is converted to the required gas application by installation of a color coded "conversion screw."

- a) Using a suitable small screwdriver lift out the central regulator cap from the "Hi-Lo" knob on the valve.
 - b) Unscrew the exposed conversion screw.
 - c) Insert the new color coded conversion screw. **Do not over-tighten the screw, it must be finger tight.**
 - d) Refit the regulator cap.
 - e) Mount conversion label supplied with conversion screw to valve in a visible position.
10. Reassemble fireplace in the reverse order, except window frame assembly. Leave this off until after unit has been checked for leaks and the gas supply has been bled.
 11. After bleeding gas line and checking for leaks with a soap solution, replace the front glass. Fire up the unit, check for flame impingement on logs, adjusting them if necessary. Check manifold and supply pressures against the appliance specifications.



The procedure for converting from one gas to another is the same regardless of the initial gas used. The only variations are in orifice sizes and component part numbers. Your authorized service provider will ensure correct parts are used.

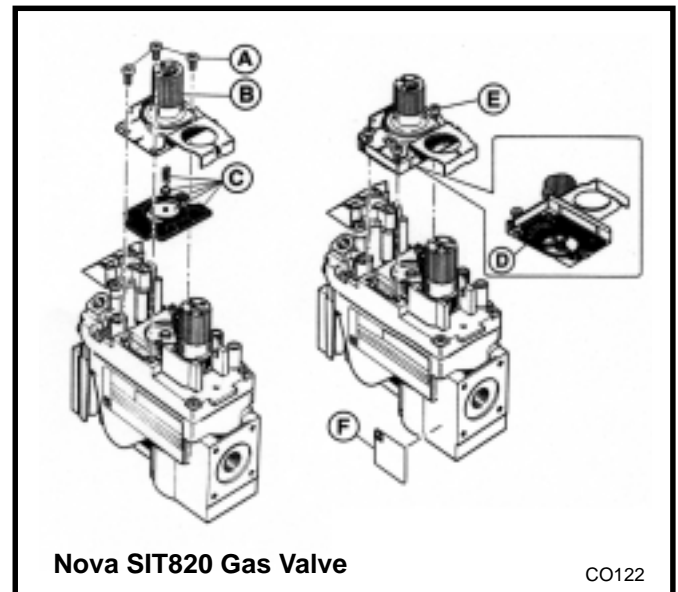

Fig. 47 Nova SIT 820 gas valve conversion.

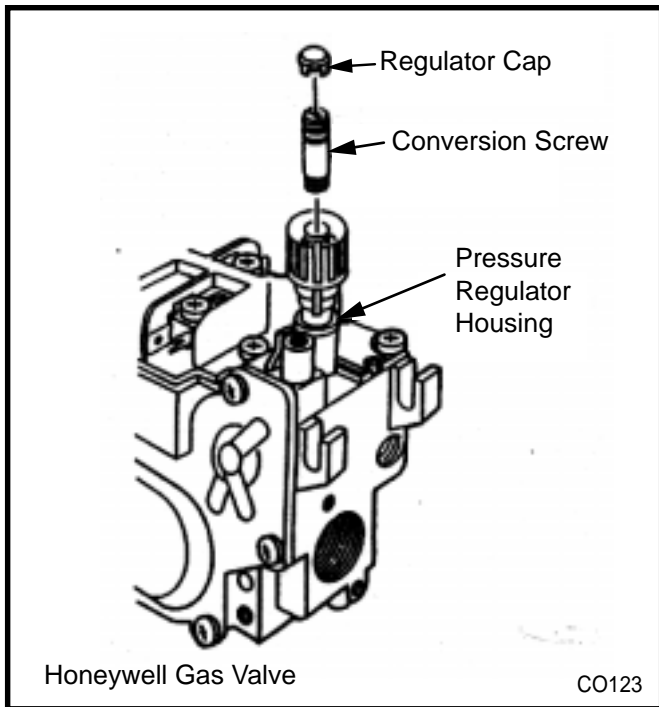

Fig. 48 Honeywell gas valve conversion.

Cleaning the Standing Pilot Control System

The burner and control system consists of:

- burner tube
- gas orifice
- pilot assembly
- thermopile
- millivolt gas valve

Most of these components may require only an occasional checkup and cleaning and some may require adjustment. **If repair is necessary, it should be performed by a qualified technician.**

1. Turn off pilot light at gas valve side.
2. Let fireplace cool if it has been running.
3. Remove window frame assembly. (Refer to Window Frame Assembly Removal section)
4. Remove logs.
5. Vacuum burner compartment especially around orifice primary air openings.
6. Visually inspect pilot. Brush or blow away any dust or lint accumulation.
7. Reinstall logs.
8. Ignite pilot; refer to Lighting Instructions.
9. Reinstall window frame assembly.

To obtain proper operation, it is imperative that the pilot and burner's flame characteristics are steady, not lifting or floating.

Typically, the top $\frac{3}{8}$ " or $\frac{1}{2}$ " of the thermopile should be engulfed in the pilot flame (Fig. 45, page 25).

To adjust pilot burner (to be done by a qualified service technician):

1. Remove pilot adjustment cap.
2. Adjust pilot screw to provide properly sized flame.
3. Replace pilot adjustment cap.

The primary air shutter is set at factory and should be adjusted, if necessary, only by a qualified service technician.

General Maintenance

Burner and Burner Compartment

It is important to keep the burner and the burner compartment clean. At least once per year the logs and lava rock/ember material should be removed and the burner compartment vacuumed and wiped out. Remove and replace the logs as per the instructions in this manual.



Always handle the logs with care as they are fragile and may also be hot if the fireplace has been in use.

FK24/FK12 Fan Assembly

The fan unit requires periodic cleaning. At least once per month in the operating season, open the lower louver panels and wipe or vacuum the area around the fan to remove any build up of dust or lint.

Brass Trim

Clean the brass trim pieces using a soft cloth lightly dampened with lemon oil. Do not use water or household cleaners on any brass components.

Contact your local representative to arrange an annual service program.

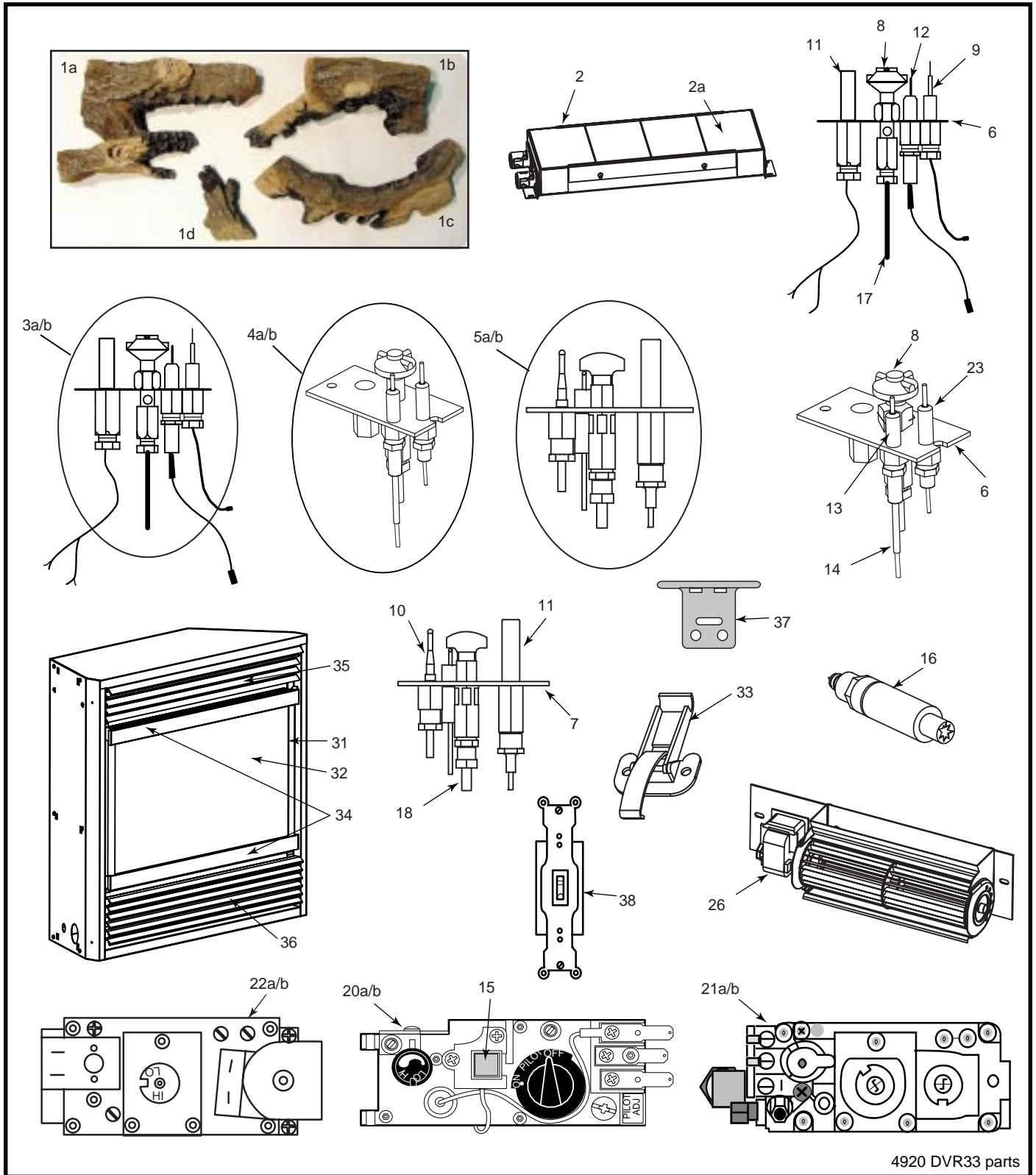

4920 DVR33 parts

Vermont Castings, Majestic Products reserves the right to make changes in design, materials, specifications, prices and discontinue colors and products at any time, without notice.

DVR33

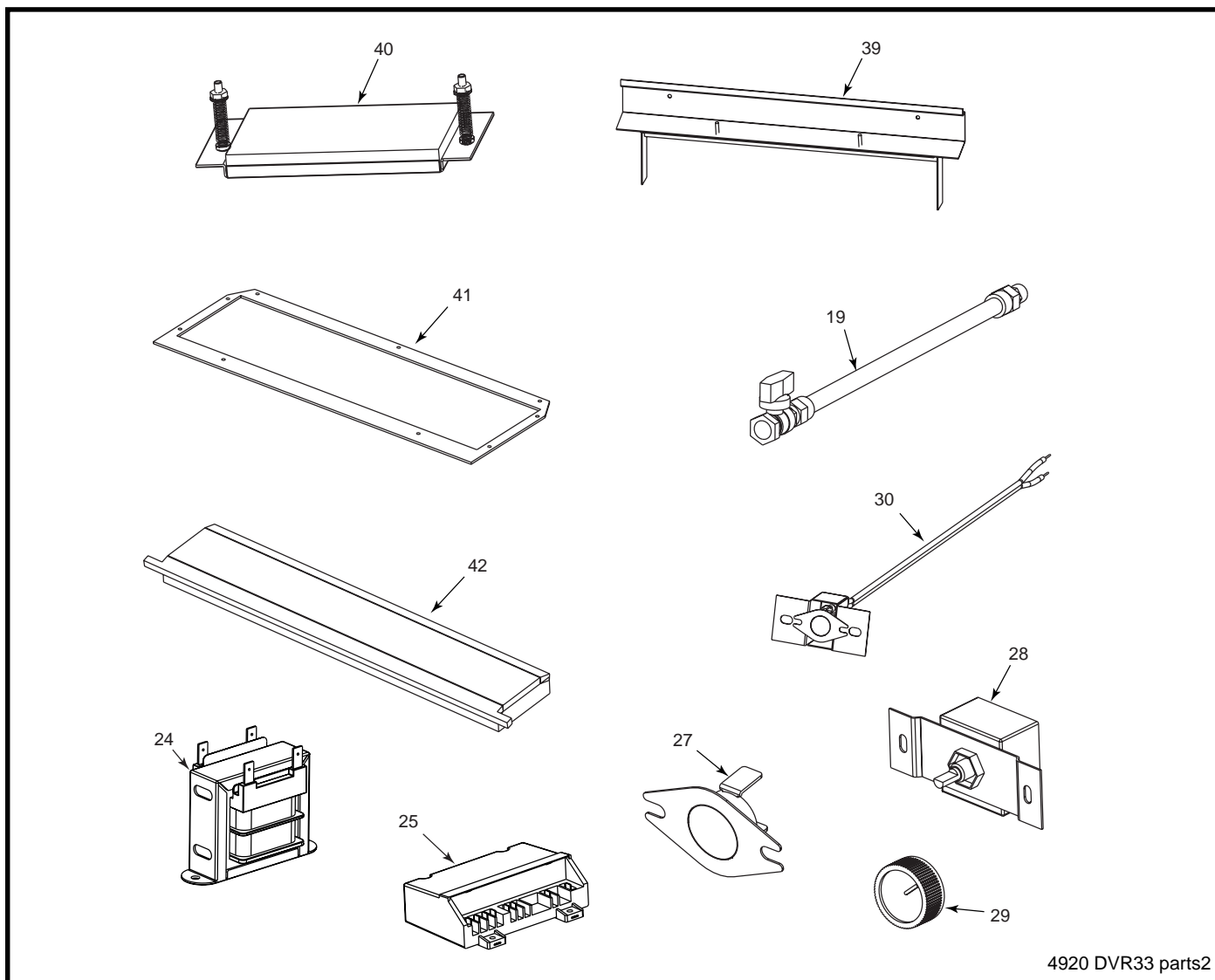

4920 DVR33 parts2

Vermont Castings, Majestic Products reserves the right to make changes in design, materials, specifications, prices and discontinue colors and products at any time, without notice.

DVR33

(Items marked with “*” are not shown in the parts illustration.)

Ref.	Description	DVR33
1.	Log Set (complete)	10004921
1a.	Log - Front/Rear Left	10004929 (A33)
1b.	Log - Rear Right	10004925 (A34)
1c.	Log - Front Right	10004928 (A35)
1d.	Log - Front Center	10004927 (A36)
*	Lava Rock 1 lb. package	10001454
*	Lava Rock Burner Package	57897
2.	Burner Housing Assembly, NG & LP	10004901
2a.	Ceramic Tile (Single)	57803
*	Orifice Burner NG and LP	See the rating plate for orifice specifications

DVR33 (continued) (Items marked “*” are not shown in the parts illustration.)

Ref.	Description	DVR33
3a.	Pilot Assembly SIT Top Convertible RN	10002264
3b.	Pilot Assembly SIT Top Convertible RP	10002265
4a.	Pilot Assembly SIT Top Convertible EN	10002387
4b.	Pilot Assembly SIT Top Convertible EP	10002388
5a.	Pilot Assembly PSE RN	10001741
5b.	Pilot Assembly PSE RP	10001742
6.	Pilot SIT Top Convertible	10002266
7.	Pilot PSE (with Cable and Electrode)	10001824
*	Pilot Orifice SIT NG	10002268
*	Pilot Orifice SIT LP	10002269
*	Pilot Orifice PSE NG	10001822
*	Pilot Orifice PSE LP	10001823
8.	Pilot Hood SIT Top Convertible	10002385
9.	Thermocouple SIT	53373
10.	Thermocouple PSE	10001825
11.	Thermopile	51827
12.	Ignitor Electrode with Cable, SIT RN/RP	10001297
13.	Ignitor Electrode SIT EN/EP	52465
14.	Cable Ignitor SIT EN/EP	10000696
15.	Piezo Ignitor Honeywell Gas Valve	20000062
16.	Piezo Ignitor SIT820 Gas Valve	52464
17.	Pilot Tube with Fittings SIT	10001296
18.	Pilot Tube with Fittings PSE	10003279
*	Manifold Tube with Fittings	57318
19.	Flexible Gas Line with ON/OFF Valve	20002500
20a.	Honeywell Gas Control Valve, RN	10001782
20b.	Honeywell Gas Control Valve, RP	10001759
21a.	SIT820 Gas Control Valve RN	52677
21b.	SIT820 Gas Control Valve RP	52678
22a.	SIT822 Gas Control Valve EN	57884
22b.	SIT822 Gas Control Valve EP	57883
23.	Sensing Electrode (w/ Cable) EN/EP	57885
24.	Transformer 24V EN/EP	7522409
25.	Ignition Module Honeywell EN/EP	20000005
*	Wire Harness Honeywell EN/EP	10001979
*	Fan Assy (FK-24 option)	ZA1100
26.	Fan with Bracket (from FK-24 Option)	54103
*	Electric Cord (from FK-24 Option)	51865
27.	Fan Temperature Sensor (from FK-24 Option)	51704
28.	Fan Speed Control (from FK-24 Option)	51738
29.	Knob Fan Speed Control (from FK-24 Option)	51882
30.	Sensor w/ Box and Wire (from FK-24 Option)	10004210
*	Fan Assembly (FK-12 Option)	ZA1110
31.	Window Frame Assembly (no glass)	10001803

DVR33 (continued) (Items marked '**' are not shown in the parts illustration.)

Ref.	Description	DVR33
32.	Window Glass with Gasket Assy	10000961
*	Gasket Window Replacement	57317
33.	Clamp Frame Window	54174
34.	Window Trim Polished Brass with Magnets	55005
35.	Top Louvre Assembly	10000292
36.	Bottom Louvre Assembly	10000293
37.	Hinge (Bottom Louvre)	52356
38.	Wall ON/OFF Switch	51842
*	ON/OFF Switch Kit	53875
39.	Bracket Rear Log Assy	10004906
40.	Relief Plate w/ Gasket (Burner Tray)	10004192
41.	Gasket Burner Tray	10001035
42.	Relief Plate w/ Gasket (Firebox Top)	10002032
*	Electric Box Assy (EB-1)	ZA1200

Optional Accessories

Fan Kits

FK-12 Fan Assembly

1. Open lower louvre.
2. Install FK12 fan in back of unit between hearth supports (Fig. 49).
3. Secure fan on Velcro strips.
4. Power to the fan can be supplied by plugging the supply lead into a conveniently located wall socket or by using a hard-wired EB-1 connector box.
5. Be sure fan motor does not touch nearby metal.

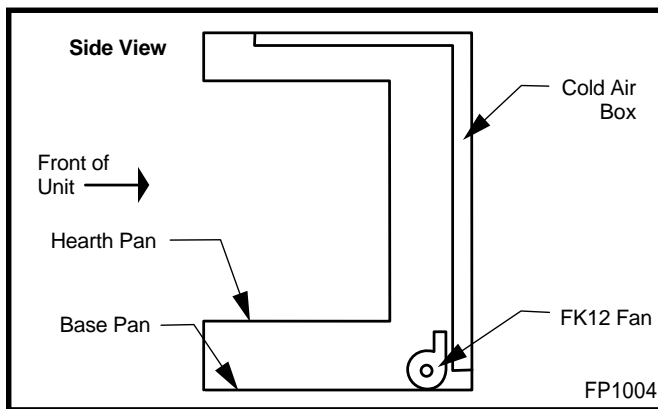

Fig. 49 FK-12 Fan placement.

FK-24 Fan Assembly

Fan specifications: 120 volt, 60 Hz, 0.75 Amp.

This fan does not need regular maintenance, however periodic cleaning is required. Check the area under the control door and in front of the fan and wipe or vacuum at least once a month during the operating season.

Should this fan require servicing, the power supply must be disconnected.

The FK-24 comes with the electrical cord attached.

1. Slide fan assembly from the left side into the fireplace opening, line up mounting holes with screw studs on back of fireplace and fasten with #10-24 hex nuts.
2. Install thermal sensor on bottom of firebox using #10-24 hex nuts.
3. **Option A**– Place electronic fan speed control box on bottom of fireplace base, lining up mounting holes with screw studs. Fasten fan speed control box with #10-24 hex nuts.

Option B– The speed control can be installed in an electrical box at normal wall switch height for convenient access.

4. Connect the power supply in one of two ways:

Method A

Route the 6' (1.8 m) lead fitted to the unit to a conveniently located wall socket.

Method B

If EB-1 receptacle box (Pt. #ZA1200) was correctly connected when the unit was installed, the fan lead can be directly plugged into the EB-1 plug socket.

5. Whether wiring directly to the fan junction box (Option A), or into EB-1 electrical receptacle box (Option B), first ensure cable is secured using box connector.

The fireplace, when installed must be electrically connected and grounded in accordance with local codes, or in the absence of local codes, with the current CSA C22.1 Canadian Electrical Code or for USA installations, follow local codes and the National Electrical Code, ANSI/NFPA No. 70.

Hard Wire (Direct) Hook-Up

First connect ground wire to ground stud located on the base of either box. Black wire from supply should connect to the variable speed switch. Alternate speed switch wire connects to temperature sensor. Alternate lead from sensor connects to fan. Alternate fan lead connects back to the white supply wire (Fig. 51).

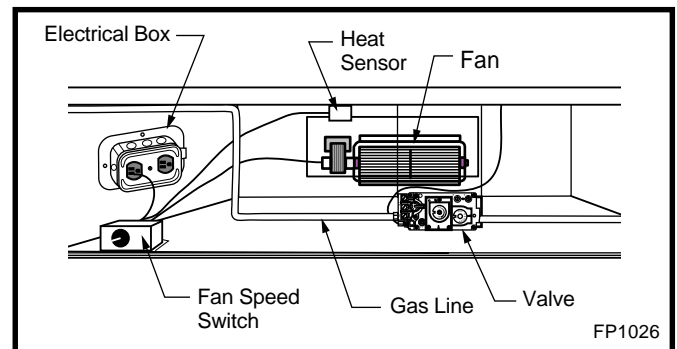

Fig. 50 FK-24 fan placement.

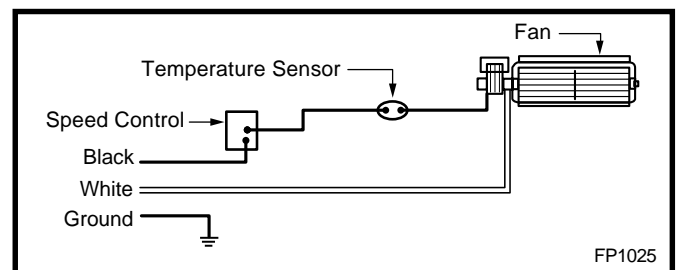

Fig. 51 FK-24 fan wiring.



Any electrical rewiring of this fan must be completed by a qualified electrician.

Turn off all power before hookup.

Remote Controls

Optional remote control units are available to control different functions of the appliance (only for RN/RP models).

Model	Function(s) Controlled
MRC1	ON/OFF
MRC2	ON/OFF and Temperature
MRC3	ON/OFF and Temperature control with a digital display and a programmable 24-hour clock
IMT	Wall-mounted thermostat control

Ceramic Refractory Panels

Ceramic refractory panels are available to line the firebox area.

Unit	Kit Model
DVR33	DVR33CR



Take care when handling the refractory panels as they are fragile until held in place and supported.

Installation (refer to Fig. 52 and Fig. 54)

1. Remove the window frame assembly
2. Remove the logs.
3. Place the lower supports for the side refractory panels on the base of the firebox. Place each support so that the slotted hole fits over the forward screw head along the edge of the base.
4. Lay the angular base panels in place on the floor of the firebox on either side of the burner housing assembly.
5. Loosely attach the top adjustable tabs to the studs located in the top of the firebox toward the front corners.
6. Place the rear refractory panel in place. Locate the 'small brick' edge of the panel into the two small supports on the back panel just above the rear log support.
7. Slide the side refractory panels into place to hold the rear panel secure. Adjust the top adjustable tabs to hold the side panel against the firebox wall and secure the tab. Repeat the procedure on the other side.
8. Replace the logs and window frame assembly.

NOTE: For aesthetic purposes, we recommend aligning the horizontal mortar lines.

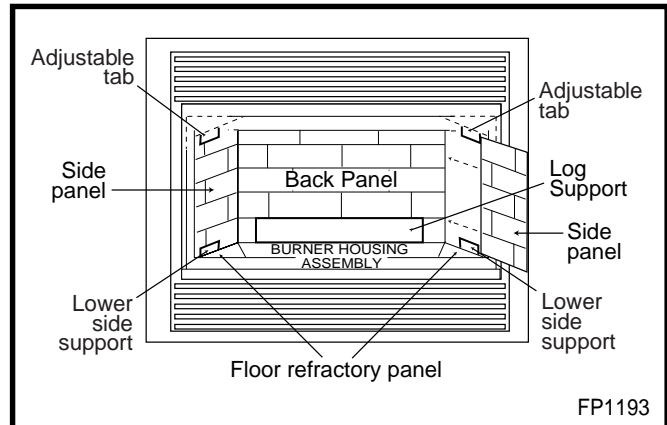

Fig. 52 Install ceramic refractory panels.

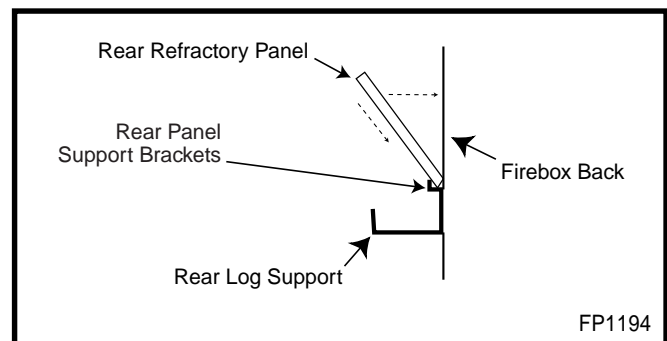

Fig. 53 Place the rear panel on rear support brackets.

Decorative Bay Windows



The original front frame/glass assembly MUST remain in place when fitting the bay window kits. The bay window kit fits over existing front glass.

Bay window kits are available for model DVR33 fireplace.

Installation

1. Remove the existing louvre assembly bottom complete with the hinges.
2. Remove the louvre assembly top.
3. Assemble the Bay Window Kit according to the instructions supplied with the kit.
4. Place the 2 pieces of ceramic refractory along the base of the bay window (Fig. 54).
5. Hang the Bay Window Assembly over the existing window frame assembly.
6. Reinstall the upper louvre assembly.



Do not remove the existing window frame assembly.

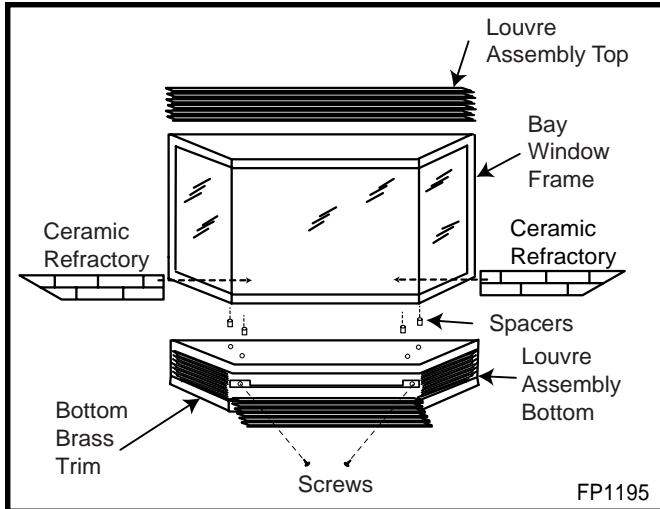

Fig. 54 Bay window.

Decorative Frame Trims

A selection of decorative frame trim kits are available for mounting around the outside of the appliance to enhance its visual effect on the room. Installation instructions for each decorative frame trim are included with the frame trim kit. Contact your authorized distributor for details of the trim kits and ordering information for the trim kits applicable to this model appliance.

LIMITED LIFETIME WARRANTY

PRODUCT COVERED BY THIS WARRANTY

All Vermont Castings gas stoves, gas inserts, and gas fireplaces, and all Majestic or Northern Flame brand gas fireplaces equipped with an Insta-Flame Ceramic Burner, or standard steel tube burner.

BASIC WARRANTY

The Vermont Castings, Majestic Products Company (hereinafter referred to collectively as the Company) warrants that your new Vermont Castings or Majestic Gas Fireplace/Stove is free from manufacturing and material defects for a period of one year from the date of purchase, subject to the following conditions and limitations.

EXTENDED LIFETIME WARRANTY

The heat exchanger, where applicable, and combustion chamber of every Vermont Castings or Majestic gas product is warranted for life against through wall perforation. All appliances equipped with an Insta-Flame Ceramic Burner have limited lifetime coverage on the ceramic burner plaque. Warrantees are made to the original owner subject to proof of purchase and the conditions and limitations listed on this Warranty Document

COMPONENT WARRANTY

CAST IRON: All external and internal cast iron parts are warranted for a period of three years.

Note: On porcelain enamel finished external parts and accessories The Company offers no Warranty on chipping of enamel surfaces. Inspect all product prior to accepting it for any damage to the enamel.

The salt air environment of coastal areas or a high humidity environment can be corrosive to the porcelain enamel finish. These conditions can cause rusting of the cast iron beneath the porcelain enamel finish, which will cause the finish to flake off.

Dye lot variations with replacement parts and/or accessories can occur and are not covered by warranty.

GLASS DOORS: Glass doors are covered for a period of one year.

Glass doors are not warranted for breakage due to misuse or accident. Glass doors are not covered for discoloration or burned in stains due to environmental issues, or improper cleaning and maintenance.

BRASS PLATED PARTS AND ACCESSORIES: Brass parts should be cleaned with Lemon oil only. Brass cleaners cannot be used. Mortar mix and masonry cleaners may corrode the brass finish. The Company will not be responsible for, nor will it warrant any brass parts which are damaged by external chemicals or down draft conditions.

GAS VALVES: Gas valves are covered for a period of one year

ELECTRONIC AND MECHANICAL COMPONENTS: Electronic and mechanical components of the burner assembly are covered for one year. All steel tube burners are warranted for one year.

ACCESSORIES: Unless otherwise noted all components and Vermont Castings, Majestic Products company supplied accessories are covered for a period of one year.

CONDITIONS AND LIMITATIONS

- This new Vermont Castings or Majestic product must be installed by a competent, authorized, service contractor. A licensed technician, as prescribed by the local jurisdiction must perform any installation/service work. It must be installed and operated at all times in accordance with the Installation and Operating instructions furnished with the product. Any alteration, willful abuse, accident, or misuse of the product shall nullify this warranty.
- This warranty is non-transferable, and is made to the original owner, provided that the purchase was made through an authorized supplier of the Company.
- The customer must pay for any Authorized Dealer in-home travel fees or service charges for in-home repair work. It is the dealers option whether the repair work will be done in the customer's home or in the dealer's shop.
- If upon inspection, the damage is found to be the fault of the manufacturer, repairs will be authorized at no charge to the customer parts and/or labor.

- Any part and/or component replaced under the provisions of this warranty is covered for six months or the remainder of the original warranty, whichever is longest.
- This warranty is limited to the repair of or replacement of part(s) found to be defective in material or workmanship, provided that such part(s) have been subjected to normal conditions of use and service, after said defect is confirmed by the Company's inspection.
- The company may, at its discretion, fully discharge all obligations with respect to this warranty by refunding the wholesale price of the defective part(s)
- Any installation, labor, construction, transportation, or other related costs/expenses arising from defective part(s), repair, replacement, or otherwise of same, will not be covered by this warranty, nor shall the Company assume responsibility for same. Further, the Company will not be responsible for any incidental, indirect, or consequential damages except as provided by law.
- *SOME STATES DO NOT ALLOW FOR THE EXCLUSION OR LIMITATIONS OF INCIDENTAL AND CONSEQUENTIAL DAMAGES OR LIMITATIONS ON HOW LONG AN IMPLIED WARRANTY LASTS, SO THE ABOVE LIMITATIONS MAY NOT APPLY TO YOUR CIRCUMSTANCES. THIS WARRANTY GIVES YOU SPECIFIC RIGHTS AND YOU MAY HAVE OTHER RIGHTS WHICH VARY FROM STATE TO STATE.*
- All other warranties-expressed or implied- with respect to the product, its components and accessories, or any obligations/liabilities on the part of the Company are hereby expressly excluded.
- The Company neither assumes, nor authorizes any third party to assume on its behalf, any other liabilities with respect to the sale of this Vermont Castings, Majestic product
- The warranties as outlined within this document do not apply to chimney components or other non Vermont Castings, Majestic accessories used in conjunction with the installation of this product..
- Damage to the unit while in transit is not covered by this warranty but is subject to claim against the common carrier. Contact the dealer from whom you purchased your fireplace/stove (do not operate the appliance as this might negate the ability to process the claim with the carrier).
- The Company will not be responsible for:
 - a) Down drafts or spillage caused by environmental conditions such as near-by trees, buildings, roof tops, hills, or mountains.
 - b) Inadequate ventilation or negative air pressure caused by mechanical systems such as furnaces, fans, clothes dryers, etc.
- This warranty is void if:
 - a) The fireplace has been operated in atmospheres contaminated by chlorine, fluorine, or other damaging chemicals.
 - b) The fireplace has been subjected to prolonged periods of dampness or condensation
 - c) Any damages to the fireplace, combustion chamber, heat exchanger or other components due to water, or weather damage, which is the result of but not limited to, improper chimney/venting installation.
 - d) Any alteration, willful abuse, accident, or misuse of the product has occurred.

IF WARRANTY SERVICE IS NEEDED...

- 1) Contact your supplier. Make sure you have your warranty, your sales receipt, and the model/serial number of your Vermont Castings, Majestic product.
- 2) DO NOT ATTEMPT TO DO ANY SERVICE WORK YOURSELF.