

OPERATORS MANUAL

This manual provides
Installation & Operating instructions for

VENTILATION SYSTEMS

NOTIFY CARRIER OF DAMAGE AT ONCE.

It is the responsibility of the consignee to inspect the container upon receipt of same and to determine the possibility of any damage, including concealed damage. Avtec suggests that if you are suspicious of damage to make a notation on the delivery receipt. It will be the responsibility of the consignee to file a claim with the carrier. We recommend that you do so at once.

Manufacture Service/Questions 888-994-7636.

Information contained in this document is known to be current and accurate at the time of printing/creation. Unified Brands recommends referencing our product line websites, unifiedbrands.net, for the most updated product information and specifications.



1055 Mendell Davis Drive
Jackson, MS 39272
888-994-7636, fax 888-864-7636
avtecind.com

TABLE OF CONTENTS

I.	TYPES OF SYSTEMS	1
	A. Baffle Filter	1
	B. Modular Grease Extractors [Energy Aire]	1
	C. Auto Wash [Energy Aire]	1
	D. Airflow Requirements	2
	E. Fire Extinguishing Systems	2
II.	INSTALLING THE VENTILATOR	2/3
III.	CONTROL PANEL	3
	A. Wall Attachment	3
IV.	ELECTRICAL CONNECTIONS	5
	A. VCW Control Panel	5
	B. PAWS Control Panel	5/6/7
	C. Damper and Detectors	9
	D. Ventilator Lights	9
V.	PLUMBING CONNECTIONS	9
	A. Hot Water Wash	9
	B. Cold Water Mist [optional]	9
	C. Drains	9
	D. Field Joints	9
	E. Detergent Pump and Tank	9
	F. Interconnecting	9
	G. Detergent Flow Chart	10
VI.	OPERATION	11
	A. VCW Control Panel	11
	1. Adjustment	11
	2. Sequence Of Operation	11
	3. Trouble-Shooting	11/12
	B. PAWS Control Panel	12/13
	1. Manual Operation	12/13
	a. Fan Start	13
	b. Fan Stop	13
	c. Wash Start	13
	d. Wash Stop	13
	2. Trouble Conditions	13
	a. Low Detergent Indicator	13
	b. Supervised Valve [optional]	13
	3. Hood Plenum Fire Protection	13
	a. Automatic Operation	13
	b. Manual Operation	13
	4. Programming Instructions	13/14
	a. Setting The Clock	13/14
	b. Setting The PAWS	14
	1. Single Wash Models	14
	2. Multi-Wash Models	14
	c. Setting The Fire Delay	14
	d. Reviewing The Daily Event Schedule	15
	e. Changing The Daily Event Schedule	15
	f. Repeating The Daily Event Schedule	15
	g. Holiday Feature	15
	h. Fan On During Recovery	16
	i. Power Loss	16
	j. Last Command Indicator	16
	k. Diagnostic Indicators	16
	l. Detergent Pump and Tank	18

VII.	VENTILATOR FEATURES AND ACCESSORIES	18
	A. Baffle Filter	18
	B. Modular Grease Extractors	18
	C. Auto Wash Grease Extractors	19
	D. Air Adjustment Baffle	19
	E. Fire Dampers	20
	F. Air Make-Up [Supply] Plenums	20
	G. Auto Wash	21
	H. Cold Water Mist [Optional]	21
	I. Lights	21
VIII.	PERIODIC MAINTENANCE	21
	A. Baffle Filters	21
	B. Modular Grease Extractors	21
	C. Grease Trough	21
	D. Grease Collection Receptacle	22
	E. Hood Canopy	22
	F. Detergent System	22
	G. Fusible Link Replacement	22
IX.	PARTS LIST	
	A. PAWS Panel - Electrical	23
	B. VCW Panel - Electrical	23
	C. PAWS/VCW Panel - Plumbing	23
	D. EVAC Detergent	24
	E. Electro-Mechanical Damper	24
	F. Fusible Link Damper	25
	G. Hood Canopy	25
X.	OTHER DATA AND DRAWINGS	
	A. EVAC Cleaner Cut Sheet	27
	B. Air Movement Recordings	28
	C. Calculating and Recording Air Movement Readings	29
	D. Calculating and Recording Air Movement	30
XI.	WARRANTY	31

1. TYPES OF SYSTEMS

This manual covers three [3] of the basic types of systems offered by AVTEC - Baffle Filter [AF], Modular Grease Extractor [AX] and Auto Wash Down [AW].

A. Baffle Filter [AF Series] [See fig. #1]

Model AF ventilators are listed by Underwriters Laboratories Inc. [UL] and are built in accordance with the National Fire Protection Association [NFPA] Standard No. 96 for use with UL Listed fire extinguishing systems for duct hood protection. They are available with or without an automatic exhaust fire damper. They utilize UL Classified removable baffle filters to extract grease and provide a limited fire barrier. The canopy contains an integral grease trough and removable grease receptacle(s). Surface, plenum and duct collar fire extinguishing systems may be factory supplied.

Vent Control Panels may be supplied with these systems. See additional wiring diagrams for options.

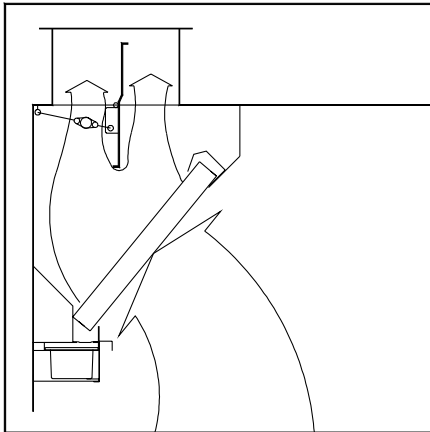

fig. 1

Installation shall be in accordance with NFPA 96.

B. Modular Grease Extractors [AX Series] Energy Aire [see fig. #2]

Model AX ventilators are listed by UL and built in accordance with NFPA Standard No. 96 for use with UL Listed fire extinguishing systems for duct and hood protection. They are available with or without an automatic exhaust fire damper.

These models utilize high velocity removable grease extractors. This exclusive design extracts up to 95%* of airborne grease contaminants. The

¹ *Data from independent tests not a part of UL test procedure.

canopy contains an integral grease trough and grease collection receptacle(s). Surface, plenum and duct collar fire extinguishing systems are

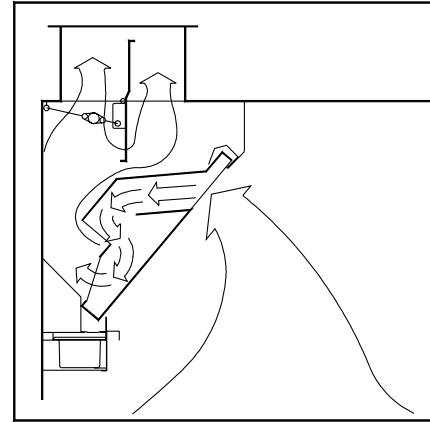

fig. 2

required and may be factory supplied.

Vent control panels may be supplied with these systems. See additional wiring diagrams for options.

Installation shall be in accordance with NFPA 96.

C. Auto Wash Down [AW Series] Energy Aire [see fig. #3]

Model AW ventilators are listed by UL and built in accordance with NFPA Standard No. 96 for use with UL Listed fire extinguishing systems for duct and hood protection. They are available with or without an automatic exhaust fire damper.

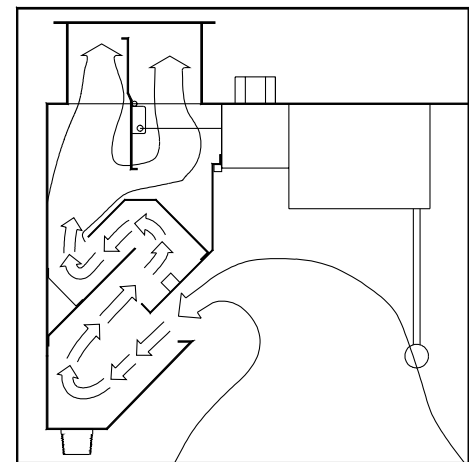

fig. 3

These systems utilize a high velocity grease extractor. This exclusive design extracts up to 95%* of airborne grease contaminants. An

integral water wash system cleans the inside of the grease extraction chamber either by manual activation of the Wash Start button or by a programmable timer. The duration of the wash is electrically controlled. The wash system is also activated by an electrical thermostat or a manual switch in the event of a fire condition. A surface fire extinguishing system is required and may be factory supplied.

Auto Wash control panels are provided with these systems. Wiring diagrams are provided with this manual.

Installation shall be in accordance with NFPA 96.

D. Airflow Requirements

Minimum exhaust airflow requirements and maximum make-up airflow requirements [where air is introduced directly inside the canopy] are shown on the chart below. These flow rates were established under laboratory conditions. Greater exhaust airflows and/or reduced make-up airflows may be required for complete capture.

CFM REQUIREMENTS			
Model No.	400°F Cooking Surface Equip.	600°F Cooking Surface Equip.	700°F Cooking Surface Equip.
AFWO,AFBO	200	300	525
AFDO,AFWP			
AFBP,AFDP			
AFWE,AFDE			
AFBE			
AFWI,AFBI	250[175]	N/R	N/R
AFDI,AFWD			
AFBD,AFDD			
AFIO,AFIP	250	400	600
AFIE			
AFII,AFID	300[150]	N/R	N/R
AXWO,AXBO	200	275	525
AXDO,AXWP			
AXBP,AXDP			
AXWE,AXDE			
AXBE			
AXWI,AXBI	250[175]	N/R	N/R
AXDI,AXWD			
AXBD,AXDD			
AXIO,AXIP	250	400	600
AXII	300[150]	N/R	N/R
AWWO,AWWP	194	270	*525
AWWE,AWDO			
AWDP,AWDE			
AWBO,AWBP			
AWBE			
AWWI,AWBI	250[190]	270[146]	N/R
AWDI,AWWD			
AWBD,AWDD			
AWTE,AWTP	400	420	N/R
AWTO			

N/R = Not Recommended

*=Manufacturer's test results not yet submitted to U.L. for capture tests.

E. Fire Extinguishing Systems

There are two basic types of ventilator fire extinguishing systems in use today:

Wet Chemical and Water Mist. Wet Chemical Systems may be all or partially factory installed [by the Fire System Manufacturer]; final hook up and certification at job site is done by the Fire System Manufacturer's local representative. These systems must be periodically inspected, and critical parts replaced. It is suggested that a service contract be purchased from the local representative. For further details refer to the manufacturer's technical manual.

AVTEC manufactures and installs a water mist fire extinguishing system, "MIST-A-FIRE", that connects to the building fire sprinkler system [must be "wet" type system]. Final connect of this system must be done in the field by the sprinkler contractor or authorized plumber. A certification/inspection report is done by an authorized AVTEC representative. Periodic inspection is generally required, but replacement of parts and periodic maintenance is virtually eliminated. For further details, refer to the AVTEC MIST-A-FIRE Installation and Operating Technical Manual.

II. INSTALLING THE VENTILATOR

The ventilator is supplied with brackets to facilitate the attachment of hanger rods to the vent. Hanger rods should be attached to all brackets to ensure proper support.

A. Ascertain that the ceiling/roof structure is strong enough to support the weight of the hood and support system. The approximate weight of the hood is shown below:

45 lbs/linear ft. for hoods w/o AMU plenums.

55 lbs/linear ft. for hoods w/AMU plenums.

125 lbs for fire control cabinet.

B. Carefully uncrate the hood so as not to dent or scratch the outer surface.

C. Position the hood on the floor in approximately its final installed location.

D. Use 1/2" threaded rods to hang the hood. The hanger rods should be approximately 1/2" closer to the wall at the structural attachment location than at the top of the hood. [see fig. #4] This ensures that the hood is held tightly against the wall.

Note! Do not remove Support Brace until Ventilator installation is complete. Upon completion of installation, dispose of Support Brace and replace the Acorn Nuts to their original locations.

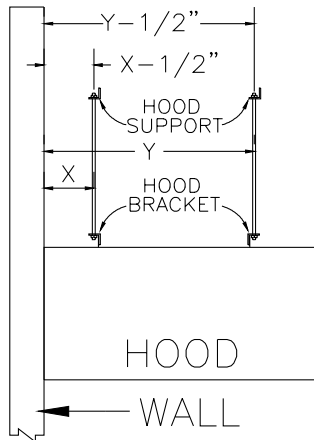

Fig 4

E. The hood should be hung so that the bottom of the hood is 6'-6" above the finished floor unless otherwise specified. Carefully lift the hood into position being certain to avoid scratching the finished surfaces. Install 1/2" threaded rod from each bracket and the structural support. Secure rods with heavy duty nuts. [see fig. #5] Be sure that the hood is level.

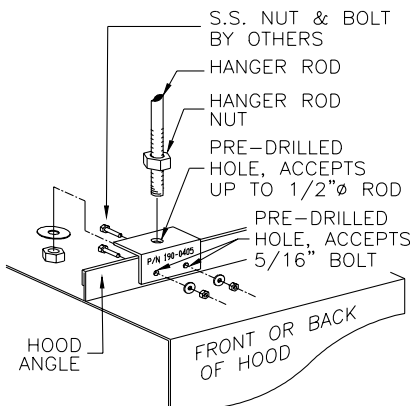

Fig 5

Tower Interface Detail

Place trim collar on tower. Position tower under hood. Fully tighten trim collar retainer hardware after tower and hood are aligned properly. See fig. A, B, and C (next page).

F. The entire exhaust duct system must be continuously welded. This includes the connection to the duct collar and the roof curb. All welds must be liquid tight.

NOTE: Welds must not impede operation of damper.

G. Connect the lights to the circuit breaker panel through the light switch. All connections should be in compliance with NFPA 70, *National Electric Code* [NEC].

H. Install bulbs in the light fixture[s].

I. Install the grease filters [AF] or modules [AX].

J. Install the grease receptacles [AF or AX]

NOTE: A minimum of a three inch [3"] insulated fire barrier and air space must be maintained between the capture area skin of the ventilator and any combustible surface, including wall and ceiling. AVTEC ventilators normally have a 3" air space; insulation is added when specified.

III. CONTROL PANEL [if provided]

Control panels are provided with all auto wash type ventilators [Models AW-] and are optional with the baffle filter type [AF-] and modular grease extractor type [AX-]. Control panels with Models AF- and AX- do not have the auto wash plumbing assembly compartments. Any control panel may be provided with a integral MIST-A- FIRE Extinguishing System alarm panel and sprinkler assembly piping; refer to the MIST-A-FIRE technical manual.

A. Wall Attachment

Control panel dimensions and connection detail are shown on the enclosed shop drawing. Panels may be surface mounted, partially recessed or fully recessed as shown on fig. 6.

1. Surface Mounted

Drill four [4] holes in ventilator plumbing compartment as required. Be careful not to damage any components. Avoid drilling into electrical compartments. Bolt to wall with anchor bolts or other acceptable means. Weight of control panel varies from 90 lbs. to 200 lbs.

2. Recessed

Cut hole in wall 1/2" greater than O/A dimensions of control box [shown on shop drawing]. Spacers or support angles may be necessary to provide proper support. It is recommended that panel be bolted to wall similar to method used for surface mounted above.

UDS FLUSH FIT TOWER

HOOD INTERFACE DETAIL

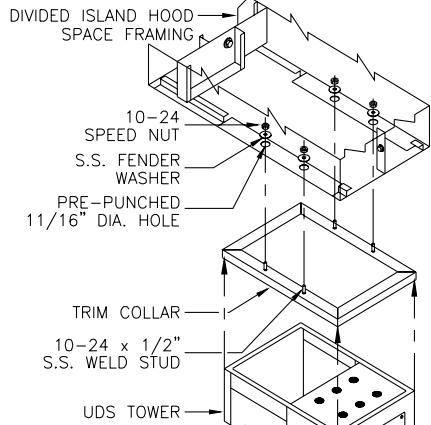

FULLY TIGHTEN TRIM COLLAR RETAINING HARDWARE AFTER THE UDS TOWER IS LOCATED UNDER THE HOOD. THE MOUNTING HOLES IN THE HOOD ARE OVERSIZED TO ALLOW SOME FLOAT FOR ALIGNMENT.

UDS 2" TOWER PENETRATION

HOOD INTERFACE DETAIL

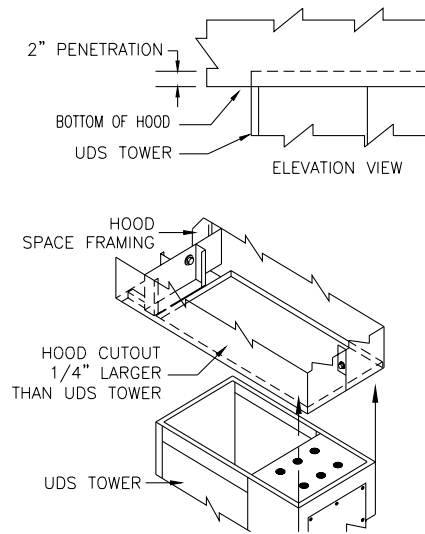

fig. A

UDS FLUSH FIT TOWER

ASSEMBLY DETAILS

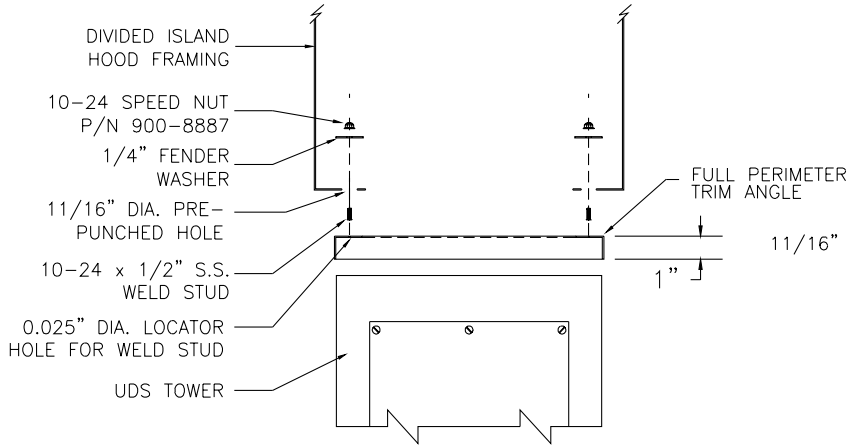

fig. B

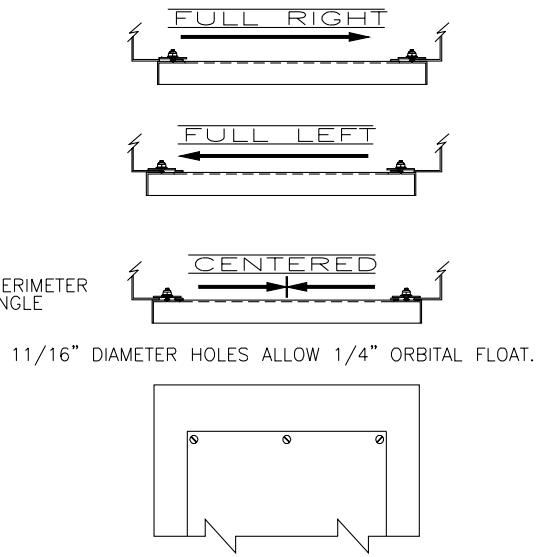

fig. C

SECTION VIEW

	DATE 7-16-98	SCALE N.T.S.	TITLE Vent to Risor Interface
	DWG. NO. VTMNFGB.DWG		
	DRAWN BY CDS		

IV. ELECTRICAL CONNECTIONS

A. VCW Control Panel [Refer to fig. 7]

1. Typical field connection terminals for VCW Control Panel are shown in fig. 7. For custom features such as sequential wash, time delay, etc. refer to AVTEC shop drawing in back of this manual.

2. Terminals No. 1 and No. 2 are for the 120vac Power Supply. Terminal No. 1 is Hot and Terminal No. 2 is Neutral.

3. Terminals No. 3 and No. 4 are 120vac power for the Water Solenoid and Detergent Pump. These terminals are "hot" whenever the Water Wash Solenoid and the Detergent Pump is scheduled to be "ON" or when there is a fire condition. Terminal No. 5 provides power for a pump/prime switch with a momentary closed/normally open contact. This switch is helpful in checking the performance of the pump as well as in priming the pump.

B. Programmable Automatic Wash Sequence [PAWS] Control Panel

1. Typical Field Connections for the PAWS Control Panel are shown on [figs. 10, 11, and 12]. Note that all options and connections may not be included on your system.

2. Terminal Block #1 [TB-1] has three [3] terminals and is located on the right-hand side of the Input/Output [I/O] Board. Terminal #1 [uppermost] is for the Hot lead of the power supply and is protected by a fuse located within the panel. Terminal #2 [center] is for the Neutral lead of the power supply. Terminal #3 [lowermost] is used to ground the Input/Output Board to the Control Panel Housing.

Terminal No. 4 is Hot and Terminals No. 2 & 3 are Neutral.

3. Terminals No. 3 and No. 6 carry 120vac whenever the fans are scheduled to be ON. They are used to activate the fan contactor[s]. In the event of a fire situation, power is removed from Terminal 5 which provides power for Terminal No. 6. Terminal No. 6 is the Hot lead and Terminal No. 3 is Neutral.

AVTEC VENT PANEL INTERFACE WIRING DIAGRAM: VCWW

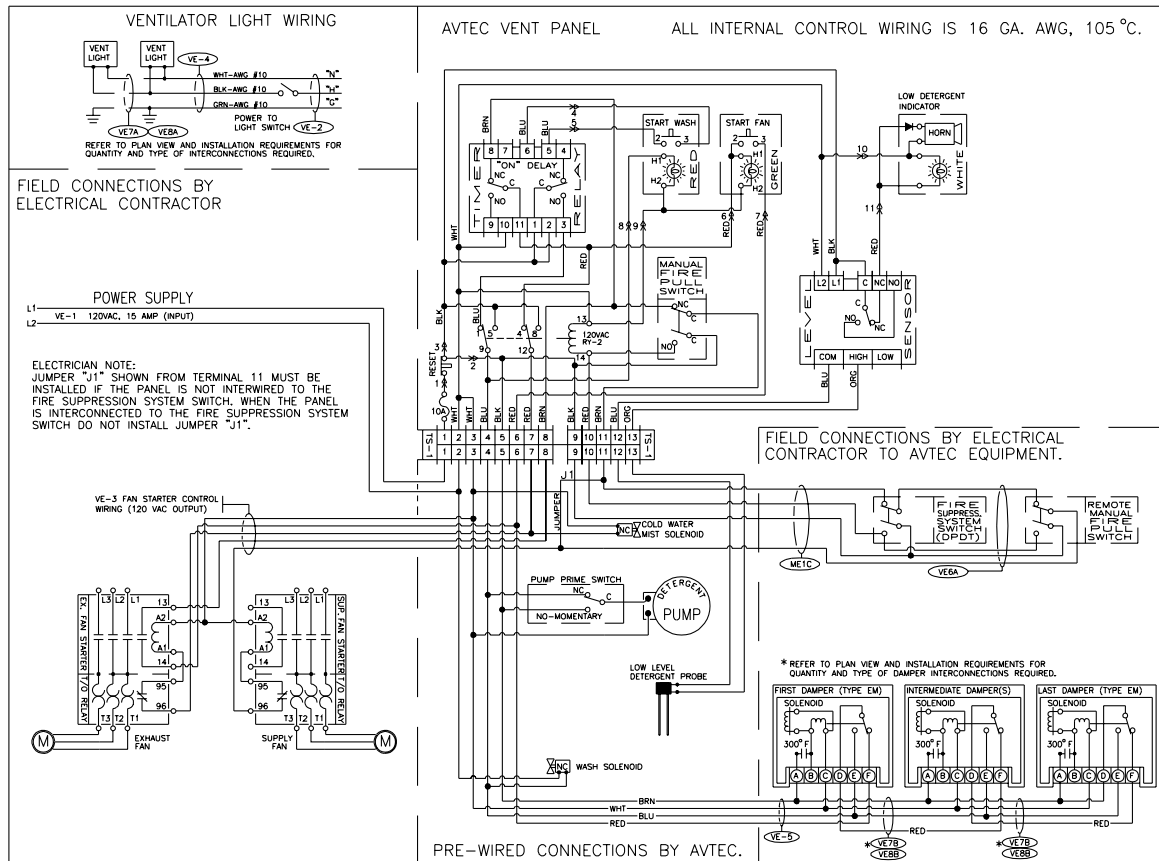

Fig. 7

4. Terminal Block #2 [TB-2] has three [3] pairs of terminals and is located at the upper right corner of the Input/Output Board. The first pair of terminals are for the number one wash valve solenoid. This will be the only wash output active in a P-10-__ or P-15-__ Control Panel. The second pair of terminals are for the number two wash valve solenoid. The third pair of terminals are for the number three wash valve solenoid.

5. Terminal Block #3 [TB-3] has three [3] pairs of terminals. It will not be present on P-10-__ or P-15-__ Control Panels. The first pair of terminals are for wash valve solenoid number four. The second pair of terminals are for the number five wash valve solenoid. The third pair of terminals are for the number six wash valve solenoid.

6. Terminal Block #4 [TB-4] has three [3] pairs of terminals. It will not be present on P-10-__ or P-15-__ Control Panels. The first pair of terminals are for the number seven wash valve solenoid. The second pair of terminals are for the number eight wash valve solenoid.

7. Terminal Block #5 [TB-5] has three [3] pairs of terminals. The first pair provides power for the detergent pump. The second pair provides power for the PAWS Alarm/Trouble horn. [The third pair provides power for the vent fan contactors. [see figs. #8a & 8b]

Note that the maximum output is one-and-one-half [1-1/2] amperes. If the total inrush current for all contactors will exceed this limit, an intermediate relay must be used.

8. Terminal Block #9 [TB-9] has three [3] pairs of terminals and is located at the lower left corner of the Input/Output Board. The first pair of terminals are for connection to the optional supervised shut-off valve. If the panel is not equipped with this option, a jumper wire must be installed. The second pair of terminals are for connection to the Manual Fire Switch. The third pair of terminals are for connection to the automatic fire switch contacts.

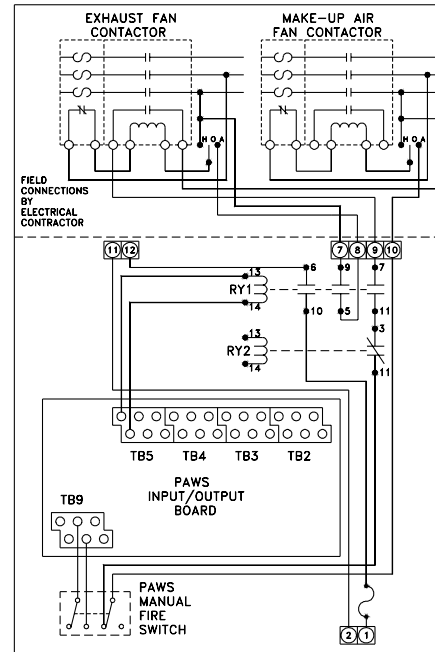

Fig 8a

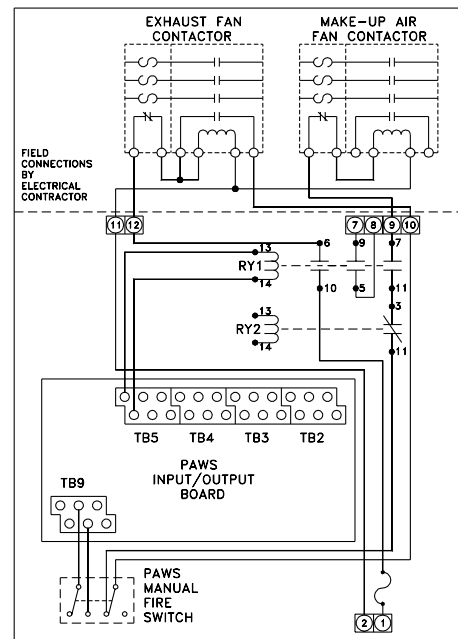

Fig 8b

9. Terminal Block #11 [TB-11] has three [3] pairs of terminals. The first pair of terminals are low voltage connections for the detergent low level probe. The probe should be installed in the detergent container so that it does not protrude above the top of the detergent pump inlet strainer. [fig. #9] This is intended to prevent cavitation of the pump and will advise when the tank needs to be refilled. The probe rods may be cut to facilitate a neat and effective installation.

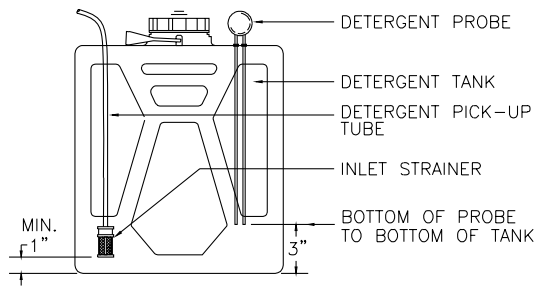

Fig 9

10. Terminal Block #12 [TB-12] has three [3] pairs of terminals. The first pair of terminals are for connection to the optional battery.

Terminal Block Designation

[For authorized service technician use only]

B. PAWS Control Panel

TB-1	1-Line Hot 2-Line Neutral 3-Mech. Ground	Incoming Power Supply 120vac, 15 amps, 60 Hz	
TB-2	1-Switched Hot 2-Neutral 3-Switched Hot 4-Neutral 5-Switched Hot 6-Neutral	Wash Solenoid #1, 120vac, 1.5 amps max Wash Solenoid #2, 120vac, 1.5amps max Wash Solenoid #3, 120vac, 1.5amps max	
TB-3	1-Switched Hot 2-Neutral 3-Switched Hot 4-Neutral 5-Switched Hot 6-Neutral	Wash Solenoid #4 120vac, 1.5amps max Wash Solenoid #5 120vac, 1.5amps max Wash Solenoid #6 120vac, 1.5amps max	
TB-4	1-Switched Hot 2-Neutral 3-Switched Hot 4-Neutral	Wash Solenoid #7 120vac, 1.5amps max Wash Solenoid #8 120vac, 1.5amps max	
TB-5	1-Switched Hot 2-Neutral 3-Switched Hot 4-Neutral 5-Switched Hot 6-Neutral	Detergent Pump, 120vac, 1.5apms max PAWS Alarm Horn, 120vac, 1.5amps max Fan Contractor, 120vac, 1.5amps max	
TB-6	1-Switched Hot 2-Neutral *3-Switched Hot *4-Neutral 5-Neutral 6-Hot	Spare Output [PAW] 120vac 1.5amps max Spare Output [MAF II] 120vac, 1.5amps max Auxillary Power Tap 120vac, 120amps max	
TB-7	*1-NC *2-C *3-NO *4-NC *5-C *6-NO	Trouble Dry Contacts [MAF II] 1.5amps @ 28vdc/120vac Trouble Dry Contacts [MAF II] 1.5amps @ 28vdc/120vac	
TB-8	*1-NC *2-C *3-NO *4-NC *5-C *6-NO	Fire Dry Contacts [MAF II] 1.5amps @ 28vdc/120vac Fire Dry Contacts [MAF II] 1.5amps @ 28vdc/120vac	
TB-9	1-Line Hot 2-Switched Hot 3-Line Hot 4-Switched Hot 5-Line Hot 6-Switched Hot	PAWS Supervised] Valve Switch PAWS Manual 120vac, 25 milliamps Fire Pull Switch PAWS Automatic Fire Switch]	
TB-10	*1-Line Hot *2-Switched Hot *3-Line Hot *4-Switched Hot *5-Line Hot *6-Switched Hot	MAF II Water] Flow Switch MAF II Water 12vdc, 25 milliamps Pressure Switch MAF II Supervised Valve Switch]	
TB-11	1-Detergent 2-Probe *3-Positive *4-Negative	20vdc, 2 milliamps MAF II Horn, 12vdc, 1.5amps	
TB-12	1-Positive 2-Negative 3-Positive 4-Negative	Battery, 12v, 5A Hours Auxillary Power Tap	

*See "Mist-A-Fire Technical Manual" (fig. 10)

C. Dampers & Detectors [AW & optional AX Models] [Fig. 13]

Terminal block in the damper housing is pre-wired to a junction box above. The wires are color-coded; refer to field interconnection wiring diagram. [Refer to enclosed control panel wiring diagram]. Interconnection may be required between damper housings.

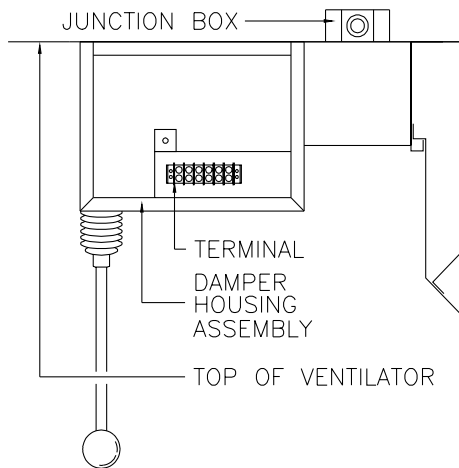

Fig. 13

D. Ventilator Lights

A 120vac supply circuit must be supplied thru a ventilator light switch to the ventilator. The light switch may be supplied by AVTEC in the control panel or on the hood. Interconnection may be required between light fixtures.

V. PLUMBING CONNECTIONS

[AW Models] [Refer to fig. 14]

The connections listed below are shown on page 8.

A. Hot Water Wash

140° hot water is needed to properly clean the extractor chamber. Supply is connected to the control panel inlet. Control panel outlet is connected to the ventilator inlet[s].

NOTE: A vacuum breaker and check valve must be installed at least 6" above the ventilator inlet to prevent back-up of detergent water into fresh water supply.

B. Cold Water Mist [Optional]

Cold water supply is connected to the control panel inlet. Control panel outlet is connected to the ventilator inlet[s].

C. Drain[s]

The drain pipe is connected at one or both ends of the ventilator and run to an air gap assembly, hub & funnel or open floor drain to act as an anti-siphoning device. An air gap assembly is recommended for the most sanitary and positive connection. The air gap should be the same size on the inlet end and one pipe size larger on the outlet to avoid splash over.

D. Field Joints

Interconnection between field joints on AW Hood attach with 2" elbows and expandable coupler. [Refer to fig. 11]

Error! Not a valid link.

Fig. 11

E. Detergent Pump and Tank

Detergent pump tubing [plastic, copper or stainless steel] must be provided from the detergent pump outlet to an injection point between the vacuum breaker/check valve and the ventilator inlet. For larger installations multiple pumps are used. Normally the detergent pump and tank are located in the control panel, and tubing from the detergent pump to the detergent tank is factory connected. In the application when the detergent pump and tank are located in a remote area, tubing is provided for connection from the pump to the tank.

Pumps may be pre-wired in control panel or Energy Distribution System, or located remotely. Detergent tank must always be located within 5 ft. of the pump.

F. Interconnecting

Depending on specifications, some ventilator sections may require interconnection of hot water, cold water or drains. See shop drawing in back of this manual for detail.

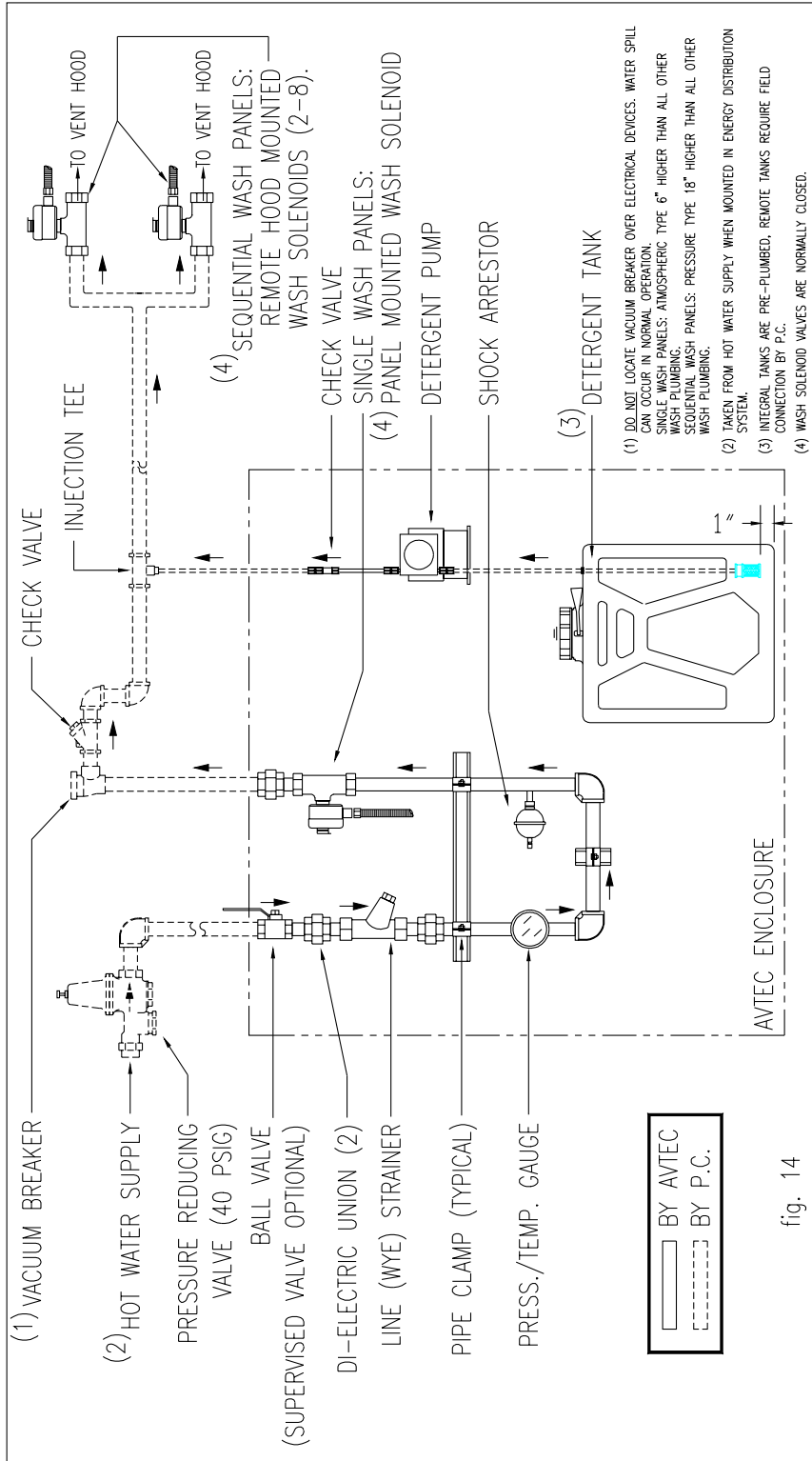

fig. 14

DETERGENT FLOW CHART

VENT LENGTH	SETTING NO.	OZ./MIN.	OZ./DAY	GAL./WEEK	GAL./MONTH
0'-12'	2	3.1	15.7	0.86	3.67
12'-19'	3	4.7	23.5	1.28	5.50
19'-25'	4	6.3	31.3	1.71	7.34
25'-38'	6	9.4	47.0	2.57	11.00

fig. 15

DATE	DWG. NO.	DRAWN BY
07-20-98	VTMNF14	CDS

TITLE
 TYPICAL AUTO WASH PLUMBING ASSEMBLY DETAIL

VI. OPERATION

A. VCW Control Panel [Refer to fig. 16]

1. Adjustment

The component layout is shown below. The only adjustment necessary is for the auto wash timer relay. Refer to Sec. VII. G, page 18 for function explanation. Normally three minutes is used for ovens, steam equipment and light duty ranges, and five minutes is used for fryers, griddles, etc. A longer wash may be required for charbroilers.

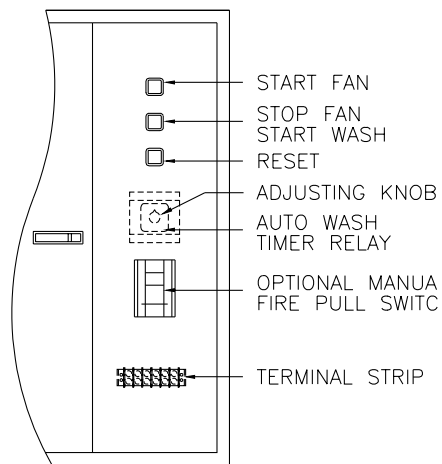

fig. 16

2. Sequence Of Operation

Press "START" Button to turn fan[s] ON. When the time comes to shut down the fan[s] [either at the end of the day or the end of the cooking period] press the "STOP" Button. If the system is equipped with auto wash, the fans will shut OFF and the auto wash and detergent pump will come ON. At the end of the Wash Cycle, the auto wash solenoid closes.

If the fans are OFF you can advance directly to the Auto Wash [Time-Delay] Period by pressing the "STOP" Button.

In the event of a fire condition, the fans will shut OFF [if they were ON] and the Auto Wash will come ON [if the unit is so equipped]. The unit will remain in this condition until the thermostwitch resets itself and then the panel will return to its mode of operation before the fire condition occurred.

NOTE: If a fire condition occurs during the timed auto wash/time-delay period, the timers

will continue to time down. For example, if the fire were to occur after 5 minutes of a 30 minute time-delay period and lasted for 15 minutes before the fire switch [manual] or thermostwitch [auto] was activated, then the fan[s] would come on for 10 minutes, then shut OFF.

3. Trouble- Shooting [VCW]

a. Fans won't activate when start button is pushed.

1. Check the wiring to the fan contactor and verify that it is wired according to the VCW panel schematic.

2. Check the inter-wiring between the VCW panel and the electro-mechanical dampers located on the ventilator hoods. If the wiring is correct proceed to step c.

3. Check terminals No. 1 and No. 2 with a voltmeter. 120vac should be present at all times. If voltage is present, proceed to step 6.

4. No voltage present. Check wiring to ensure terminals No. 1 and No. 2 have been connected to a proper 120vac power source.

5. Check that all related fuses are intact and that the circuit breaker in main circuit breaker panel is "ON".

6. Check the fire switch pull station [optional] for proper wiring and also check that it is properly closed and latched.

7. Check the dampers on all interconnected ventilator hoods for a fire condition.

8. In a normal condition damper terminals A & C will have 120vac. In a fire condition terminals B & C will have 120vac.

a. If terminals B & C have 120vac fans will not operate. Voltage present at these terminals indicates that the thermostwitches in the duct have closed. These thermostwitches automatically reset after cooling to a temperature below 300°F.

If the thermostwitch does not reset after cooling, replace it with a new thermostwitch.

b. Check for 120vac at terminals No. 2 & No. 5. This voltage should be present at all times. If voltage is present proceed to step 8c. If voltage is not present refer to step 8.a as listed above.

c. While pushing the "START" Button, terminals No. 3 and No. 7 will have 120

vac as long as the "START" Button is depressed.

d. Once the "Start" Button is released, power [120vac] will be present at terminals No. 2 & No. 6. If no power is present after releasing start button verify that the fan contactor has been wired as shown on VCW Panel Electrical Schematic.

e. Voltage present at terminals No. 2 & No. 6 after pushing "START" Button, fans won't operate. This condition indicates that the control wiring is operating properly, therefore the problem must be in the fan motor itself or the power supply wiring to fan thru the normally open contactor or the fan contactor.

b. Auto Wash Solenoid does not open.

1. Check that fuse is intact.

2. Check terminals No. 1 and No. 2 with volt meter.

a. If 120vac proceed to step 2d.

b. If no voltage, check fuse and wiring to panel.

c. Check panel circuit breaker and verify that it is "ON",

d. Press "Stop" button in completely and hold for one [1] full second.

e. Check terminals No. 3 and No. 4 with volt meter.

i. If 120vac is present, check wiring to water solenoid. Check voltage at solenoid coil. If 120vac is present, replace coil. If no voltage, refer to step 2.b.

ii. Check the timer relay inside the VCW Panel to verify that power is going thru the contacts and that the coil is engaging. If relay doesn't function properly, replace the relay, If relay functions properly proceed to step 4.

iii. Check wiring against schematic to verify that is correct. Check condition of wires and connections to verify that they are not loose or damaged.

c. Auto Wash Solenoid will not close.

1. Check terminals No. 3 & No. 4 for voltage [120vac]. If no voltage is present proceed to step e.

2. Check the wiring to the fire switch pull station to see that it has been wired to the correct contacts.

3. Check the fire switch pull station [optional] to verify it has not been pulled.

4. Check all the dampers on the ventilator to verify that none of the dampers have been activated into the fire condition.

5. Check condition of solenoid for damage or debris.

d. Solenoid coil activates but no water flow is present.

1. Check water pressure gauge. If water pressure of 25 psig or more is present proceed to steps 2 & 3. If no water pressure is present proceed to steps 4 & 5.

2. Check solenoid valve for damage or debris.

3. Check for water line blockage and verify all spray nozzles are clear.

4. Check all water supply valves to verify they are open.

5. Check and clean all line wye strainers.

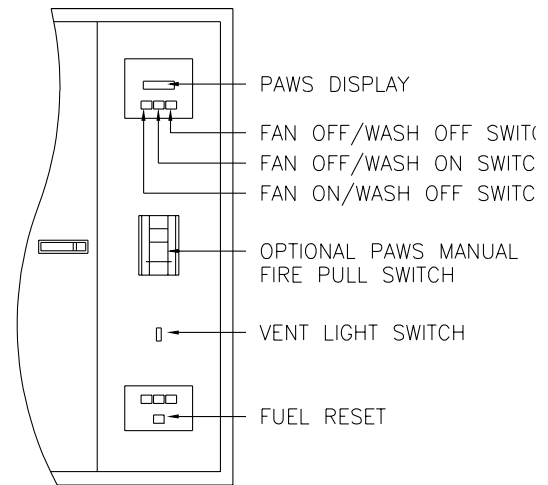

fig. 17

B. PAWS Control Panel [Refer to fig. 17]

1. Manual Operation

The Programmable Automatic Wash Sequence [PAWS] Panel is designed to control the operation of the ventilator exhaust and air make-up fans and wash the grease extraction plenum with a hot water/detergent solution. The fan operation and wash sequence can be

started and stopped manually or programmed or automatic operation.

a. Fan Start

The exhaust and air make-up fans can be started manually by pressing "FAN ON/WASH OFF" on the PAWS panel. If the wash cycle is in progress it will stop immediately and the fans will start. The PAWS display will indicate "FAN ON/WASH OFF".

b. Fan Stop

The exhaust and air make-up fans can be stopped manually by pressing "FAN OFF/WASH OFF" on the PAWS panel. The fans will stop immediately. The PAWS display will indicate "FAN OFF/WASH OFF".

c. Wash Start

The wash cycle can be started manually by pressing "FAN OFF/WASH ON" on the PAWS panel. If the fans are on, they will stop immediately. The display will indicate "WASH 1" and the total time [in hours and minutes] remaining until the wash cycle ends.

d. Wash Stop

The wash cycle can be stopped manually by pressing "FAN OFF/WASH OFF" on the PAWS panel. The wash cycle will stop immediately. The PAWS display will read "FAN OFF/WASH OFF".

2. Trouble Conditions

a. Low Detergent Indicator

If the detergent level drops below the bottom of the detergent probe, the PAWS panel horn will sound and the display will flash "DETERGENT LOW". The horn can be silenced by pressing the "VFC Horn Silence" switch, but the trouble condition will continue to be displayed. The detergent pump will not operate until the detergent tank is refilled. The fan and wash cycles will continue to operate normally, however, the display will continue to flash "LOW DETERGENT". When the detergent tank is refilled, the trouble condition will automatically clear itself after approximately 10 seconds.

b. Supervised Water Valve [optional]

If your PAWS panel is equipped with the optional supervised valve, the PAWS panel horn will sound and the display will flash "PLENUM WASH AND FIRE CYCLES LOST" when the valve is closed. The horn can be

silenced by pressing the "VFC Horn Silence" switch, but the trouble condition will continue to be displayed. The fan will operate normally, hot water will not flow during the wash cycle and the display will continue to flash "PLENUM WASH AND FIRE CYCLES LOST". When the valve is opened, the alarm condition will automatically clear itself. In the event that the detergent level drops below the probe and the optional supervised valve is closed at the same time, the horn will sound and the display will alternate between "DETERGENT LOW" and "PLENUM WASH AND FIRE CYCLES LOST". The horn can be silenced by pressing the "VFC Horn Silence" switch.

3. Hood Plenum Fire Protection

a. Automatic Operation

In the event of a fire in and/or under the ventilator, the fans will turn off and the plenum wash will be activated when the temperature at the duct collar exceeds 300°F. The display will read "AUTO FIRE CYCLE FAN OFF/WASH ON" and the PAWS panel alarm will sound. The alarm cannot be silenced. When the temperature at the duct collar drops below 300 °F, the PAWS panel will enter the fire delay cycle. During the fire delay cycle the fan will remain off and the hood plenum wash will remain on for a programmable period of time then automatically return to normal operation. The fire delay cycle can be terminated by pressing "FAN OFF/WASH OFF" on the PAWS panel. [See Sec. 4.b.2.c for setting Fire Delay Cycle Duration].

b. Manual Operation

The PAWS panel may be equipped with the optional "Manual Fire Switch". Pulling the "Manual Fire Switch" will turn on the exhaust fan(s) and activate the plenum hood wash to act as a fire barrier. The display will read "MAN'L FIRE CYCLE FAN ON/WASH ON" and the PAWS panel alarm will sound. The alarm cannot be silenced. After the "Manual Fire Switch" is reset, the PAWS panel will enter the fire delay cycle. During the fire delay cycle the exhaust fan will remain on for a programmable period of time then automatically return to normal operation. The fire delay cycle can be terminated by pressing "FAN OFF/WASH OFF" on the PAWS panel. [See Sec. 4.3 for setting Fire Delay Cycle duration].

4. Programming Instructions [Refer to fig. 17A & 17B]

a. Setting the Clock

The PAWS Control Panel is equipped with an integral clock which can be used to automatically operate the fan and wash cycles. To set the time press "RETURN CLOCK" once. The display will read "SET DAY AND TIME SELECTED" and then change to "SET DAY AND TIME" as well as the day and time. Press "CHANGE CLEAR" and the day and time will begin to flash. Press "DAY+" and/or "DAY-" to set the correct day. Press "HOUR+" and/or "HOUR-" to set the correct hour. Note if "AM" or "PM" is displayed correctly. Press "MINUTE+" and/or "MINUTE-" to set the correct minutes. When you are satisfied that the day and time are correctly displayed, press "SAVE ENTER". The display changes to the Normal Display. If no key is pressed for thirty [30] seconds, the display will automatically return to Normal Display.

b. Setting the PAWS

1. Single Wash Models [P-10__ & P-15__]

The wash can be programmed to run for up to fifteen [15] minutes. It is followed by a recovery period of from zero [0] minutes up to two [2] hours. This period can be used in installations which require that the fans automatically turn on for a period of time after the wash cycle is complete.

To review the PAWS, press "PAWS". The display will indicate "PAWS MODE SELECTED" for about three [3] seconds then change to indicate the total PAWS duration [wash and recovery periods] in hours and minutes, and the duration of the wash period in minutes. Press "NEXT" to display the duration of the recovery period. Press "NEXT" to display the duration of the fire delay cycle.

To change the duration of a segment, press "NEXT" or "LAST" until the appropriate segment is displayed, then press "CHANGE CLEAR". When the display flashes, press "MINUTE+" or "MINUTE-" until the duration is displayed, then press "SAVE ENTER" to retain that time. The total PAWS duration is automatically updated.

To change the duration of an additional segment, repeat the above procedure.

When all segments have been set, press "RETURN CLOCK" to return to Normal Display. If no key is pressed for thirty [30] seconds, the panel will automatically return to Normal Display.

2. Multi-Wash Models [P-20-__ & P-25-__]

As many as eight [8] hood sections can be programmed to wash in sequence. [The total number of washes and outputs is determined prior to shipment and set at the factory]. Each section can be programmed to wash for a different period of time, up to fifteen [15] minutes per section.

There are also up to eight [8] recovery periods which can be programmed for different durations from zero [0] minutes up to two [2] hours per segment. The recovery periods can be used to allow the water heater to recover between wash segments in installations with a limited hot water supply. It can also be used in installations which require that the fans automatically turn on for a period of time after the final wash period.

To review PAWS, press "PAWS". The display will indicate "PAWS MODE SELECTED" for about three [3] seconds then change to indicate the total PAWS duration [PAWS and recovery periods] in hours and minutes, and the duration of the first wash period in minutes. Press "NEXT" to display the duration of the first recovery period. Continue to press "NEXT" to review the remaining wash and recovery segments.

To change the duration of a wash or recovery segment, press "NEXT" or "LAST" until the appropriate segment is displayed, then press "CHANGE CLEAR". When the display flashes, press "MINUTE+" or "MINUTE-" until the desired duration is displayed, then press "SAVE ENTER" to retain that time. The total PAWS duration is automatically updated. To change additional segments, repeat the above procedure.

When all segments have been set, press "RETURN CLOCK" to return to Normal Display. If no key is pressed for thirty [30] seconds, the panel will automatically return to Normal Display.

c. Setting The Fire Delay

To change the duration of the fire delay cycle press "PAWS" to enter the PAWS Review mode. Press "NEXT" to review all of the PAWS segments. After the final PAWS segment, press "NEXT" again and the display will read "FIRE DELAY" and its duration. Press "CHANGE CLEAR" and the display will begin to flash. Press "MINUTE+" and/or "MINUTE-" until the correct duration is displayed. Press

"*SAVE ENTER*" to retain that time. Press "*RETURN CLOCK*" to return to Normal Display.

d. Reviewing The Daily Event Schedule

The Daily Event Schedule is a program which will automatically turn the fans on and off and/or initiate the PAWS up to four [4] times each day. Each day may be different from another or it may be programmed to stay off for the entire day. To review the Daily Event Schedule, press "*CHECK*". The display will show "CHECK MODE SELECTED" and then indicate the first programmed event of that day. If there are no events programmed for that day, it will display the next programmed event. If there are entries in the Daily Event Schedule, press "*NEXT*" to see the next event and/or press "*LAST*" to see the previous event. Press "*RETURN CLOCK*" to return to Normal Display. If no key is pressed for thirty [30] seconds the display will automatically change to Normal Display.

e. Changing The Daily Event Schedule

In order to make initial entries in the Daily Event Schedule or change existing entries, press "*PROGRAM DAY*". The display will show "PROGRAM MODE SELECTED" then ask which day's events are to be changed. Press "*DAY+*" and/or "*DAY-*" to select the desired day, then press "*SAVE ENTER*". If no events are programmed to occur that day, the display will indicate "FAN ON UNPROG". If events are programmed for the day selected, that day's first event will be displayed. If an event other than the one being displayed is to be entered or changed, press "*NEXT*" until the correct event is displayed. Press "*CHANGE CLEAR*".

NOTE: WHEN AN EVENT IS CHANGED, ALL EVENTS WHICH ARE SCHEDULED TO OCCUR ON THAT DAY AFTER THE EVENT BEING CHANGED ARE ERASED.

The time will begin to flash. Press "*HOURL+*" and/or "*HOURL-*" to select the desired hour. Press "*MINUTE+*" and/or "*MINUTE-*" to select the desired minute. When the correct time is displayed, press "*SAVE ENTER*". Press "*NEXT*" to access the next event.

NOTE: A "FAN ON" EVENT MUST BE FOLLOWED BY A "FAN OFF" EVENT.

Repeat the programming procedure indicated above. When you have completed programming the events for that day, press

"*RETURN CLOCK*" to return to Normal Display. If no key is pressed for thirty [30] seconds, the display will automatically return for Normal Display.

To program Daily Event Schedules for additional days, particularly if they are different from the schedule already programmed, repeat the previous steps.

f. Repeating The Daily Event Schedule

If you wish to repeat the Daily Event Schedule from one day to another, press "*REPEAT DAY*". The display will show "REPEAT MODE SELECTED", then ask which day's Daily Event Schedule is to be repeated. Select the intended day by pressing "*DAY+*" and/or "*DAY-*". When the proper day is displayed, press "*SAVE ENTER*". The display will then ask on which day that Daily Event Schedule is to be repeated. Press "*DAY+*" and/or "*DAY-*" until the proper day is displayed, then press "*SAVE ENTER*". The display will acknowledge that the schedule has been copied, then return to the starting Repeat Day display. Continue as outlined above to repeat additional Daily Event Schedules.

NOTE: IF A DAY HAS ALREADY BEEN PROGRAMMED FOR A DAILY EVENT SCHEDULE, THE ORIGINAL WILL BE ERASED AND REPLACED BY THE REPEAT SCHEDULE.

When you are finished repeating Daily Event Schedules, press "*RETURN CLOCK*" to return to Normal Display. If no key is pressed for thirty [30] seconds, the display will return to Normal Display, automatically.

g. Holiday Feature

To temporarily suspend a programmed Daily Event Schedule for a particular day during the upcoming seven [7] day period, press "*HOLIDAY*". The display will show the status of the current day. Select the day's Daily Event Schedule which you wish to suspend [make a Holiday] by pressing "*DAY+*" and/or "*DAY-*". Press "*CHANGE CLEAR*" to make that day a holiday. Press "*DAY+*" and/or "*DAY-*" to select additional Holidays press "*RETURN CLOCK*" to return to Normal Display. If no key is pressed for thirty [30] seconds, the display will automatically return to Normal Display. After the Holiday passes, the Daily Event Schedule will resume normally. The Manual Controls will operate normally during a Holiday.

h. Fan On During Recovery

The operator can choose to have the fan on during PAWS recovery periods or remain off. To have the fan come on during recovery, push down the right side of switch number one of the selector switch. To have the fan remain off during recovery, push down the left side of switch number one of the selector switch. [see fig. 19]

i. Power Loss

In the event of a power loss the clock stops but the PAWS and the Daily Event Schedule are retained for up to six [6] months.

j. Last Command Indicator

In the Normal Display, the last digit of the top row indicates the last command put into the microprocessor.

The letters used are:

- L = Power Loss
- C = Clock or Program Change
- P = Programmed Daily Event Schedule Command
- M = Manual fan or PAWS Command
- H = Holiday in progress

DAY OF WEEK	TIME	AM/PM INDICATOR	LAST COMMAND INDICATOR
FRI	06:45	PM	M
FAN	OFF/WASH		OFF

PAWS NORMAL DISPLAY



fig. 17B

PAWS

Programming Keypad

k. Diagnostic LED Indicators

Because of the use of solid state relay circuits, a conventional voltmeter may not give reliable readings as regards to the operation of the various inputs and outputs. To aid in troubleshooting, diagnostic LED indicators have been built into the left-hand side of the Input/Output Board.

They are shown below.

D-1 Green

Illuminates when the number one wash output is energized.

D-2 Green

Illuminates when the number two wash output is energized.

D-3 Green

Illuminates when the number three wash output is energized.

D-4 Green

Illuminates when the number four wash output is energized.

D-5 Green

Illuminates when the number five wash output is energized.

D-6 Green

Illuminates when the number six wash output is energized.

D-7 Green

Illuminates when the number seven wash output is energized.

D-8 Green

Illuminates when the number eight wash output is energized.

D-9 Green

Illuminates when the detergent pump output is energized.

D-10 Green

Illuminates when the PAWS Alarm Horn output is energized.

D-11 Green

Illuminates when the ventilator fan output is energized.

D-18 Red

Illuminates when the manual pull station circuit is in the normal position.

D-20 Green

Illuminates when the PAWS supervised valve is open.

D-21 Red

Illuminates when the ventilator automatic fire detection circuit is activated.

D-32 Red

Glows when the battery circuit is charging.

D-35 Red

Glows when the detergent level is low.

I. Detergent Pump and Tank

Terminals No. 23 and 24 of AVTEC terminal strip supply 120vac power to the detergent pump during the Wash Cycle[s]. The pump does not run during the Fire Cycle nor when the detergent level is below the bottom of the probe.

To start the flow of detergent, press the Pump Prime Switch while the PAWS panel is not in a wash cycle [no pressure on the outlet side of the pump]. Hold the Pump Prime Switch until there is no air in the suction line of the pump or in the pump head itself. Once there is a solid column of detergent from the tank through the pump, no further action [except to fill the detergent tank] should be required.

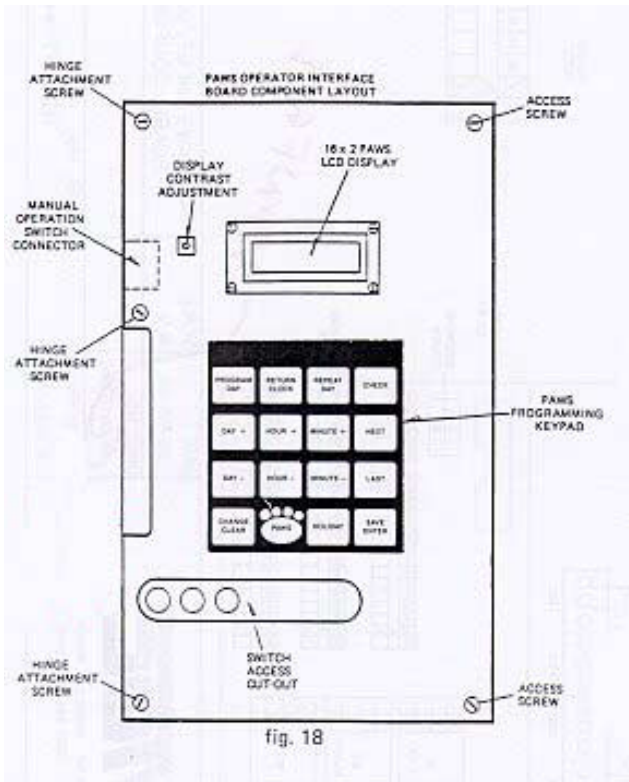

Terminals No. 21 and 22 of AVTEC terminal strip are low voltage [20vdc, 2ma] connections for the detergent level probe. The probe should be installed in the detergent container so that it is above the top of the detergent pump inlet strainer. It

is intended to prevent air from entering the pump and notify the operator when it is time to refill or replace the detergent tank. The probe rods may be cut to facilitate a neat and effective installation. [See fig. no. 9]

Detergent pumps are factory preset according to the chart in fig. no. 15. This is a generalized guide; settings may vary depending on water temperature and pressure, detergent type and concentration, grease load and PAWS duration.

VII. VENTILATOR FEATURES AND ACCESSORIES

A. Baffle Filter Ventilators [AF Models]

These type of ventilators have removable filters which extracts and collects grease in a receptacle.

1. Filter Installation [Refer to fig. 20]

Grease extractor filters are installed by sliding them into the upper slot and then lowering them into the grease trough slot as shown in the drawing below.

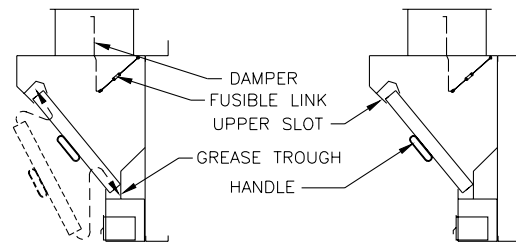

fig. 20

The filters are removed for cleaning by reversing the procedure.

NOTE: The filters must be installed with the baffles running vertically and with the handles facing toward the capture area.

2. Grease Receptacles

Grease receptacles are located at one each of each ventilator section. These must be cleaned out periodically. The frequency of this cleaning is dependent upon the type of equipment used beneath the ventilator and the duration of its use.

It is suggested that initially the grease receptacles be emptied daily.

B. Modular Grease Extractors [AX Models]

These type ventilators have removable extractor modules which extracts grease contaminants which collects in a grease receptacle at each end of the ventilator section.

1. Grease Extractor Module Installation

[Refer to fig. 21]

Grease extractor modules are installed by sliding the top [narrow] part of the module into the upper retaining slot and then lowering the bottom part of the module into the grease trough slot.

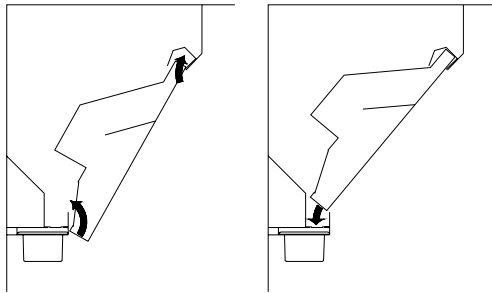

fig. 21

NOTE: Handle faces towards capture area.

2. Grease Receptacles

Grease receptacles are located at each end of each ventilator section. These must be cleaned out periodically. The frequency of this cleaning is dependent upon the type of equipment used beneath the ventilator and the duration of its use. It is suggested that initially the grease receptacles be emptied daily.

C. Auto Wash Grease Extractors [AW Models]

These type ventilators have an automatic wash cycle which requires only occasional wiping down of inside grease extractor.

1. Grease Extraction Chamber

The front panel is hinged to facilitate access to the nozzles and grease extraction baffles.

[Refer to fig.22]

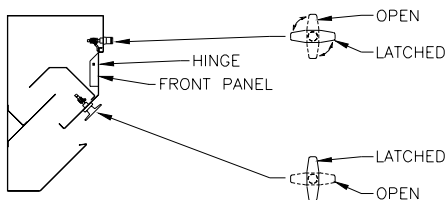

fig. 22

To open, turn all front panel latches clockwise to the open [unlatched] position and swing the bottom of the front panel out. "Kickstands" are provided at each end of the

ventilator section to hold the front panel open.

2. Spray Nozzles

Spray nozzles for hot water wash and cold water mist are protected from clogging by wye-strainers located in the plumbing enclosure. However, scale and contaminants will accumulate in time and these will require occasional cleaning to assure proper wash down and spray distribution. A paper clip or other pointed object should be used to scrape contaminants from the nozzles.

D. Air Adjustment Baffle [Refer to fig. 23]

Some grease extractor models may be equipped with air adjustment baffles at the exhaust intake slot. These baffles may be adjusted to increase or decrease the intake slot, according to the cfm desired or required for varying pieces of cooking equipment underneath. The length of the baffles varies according to project design specifications and conditions. The standard opening of nominal 3" yields approximately 250 cfm/linear ft. and is used for most cooking appliances. Air flow may be reduced to a low as 150 cfm/linear ft. for ovens, steamers, etc. depending on local job conditions. Adjusting the slot to nominal 1-3/4" opening will yield approximately 150 cfm/linear ft.

The Thrift Island Series ventilators uses only one grease extraction chamber and is designed for 250-270 cfm/linear ft. on the cooking side and 150 cfm/linear ft. on the oven/steamer side. These units are provided with air adjustment baffles to "fine-tune" the balance of air from each side, and to change air velocity as job conditions dictate.

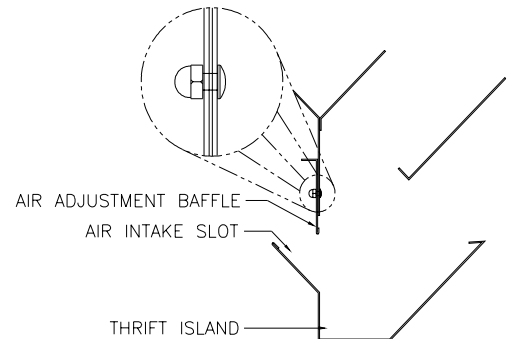

fig. 23

To adjust air intake slot, turn nuts to loosen, move air adjustment baffles up or down until the desired slot opening is obtained, and tighten nuts.

E. Fire Dampers

1. Fusible Link Type

Some ducts are protected by fire dampers which are activated by a fusible link rated at 360°F exhaust and 286°F supply. When this temperature is exceeded, the fusible link melts allowing the fire damper to fall closed. This linkage should be inspected and the fusible links replaced annually. Fusible links in the exhaust duct collar are readily accessible by removing the baffle filters [Models AF] or grease extractor modules [Models AX]. [Refer to fig. 20 and 24] An access plate is provided for access [supply] duct collar for all models.

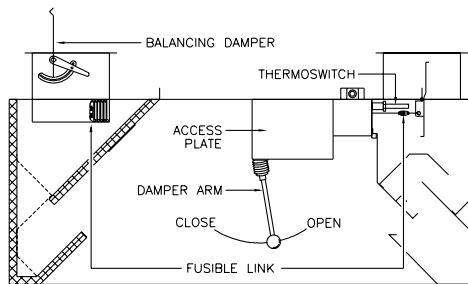

fig. 24

Electro-Mechanical Type [Refer to fig. 24]

Some ducts are protected by fire dampers which are activated by heat sensitive thermostats located near the duct inlet. These switches close electrically at temperatures above 300° F and activate a solenoid which releases the damper, and energizes a relay which activates the plenum auto wash/fire extinguishing spray and deactivates the fan. In the event of a loss of power, the damper assembly also contains a fusible link, set at 360°F.

The damper can be manually closed by pulling down on the red knob at the end of the damper reset arm and allowing it to swing away from the plenum.

If the damper has been activated by excessive temperature, it cannot be reset until the temperature has dropped below 300°

F. After the temperature has dropped below 300°F, the damper can be reset and opened by pushing the damper reset arm toward the plenum until it latches.

If the fusible link has melted, it must be replaced before the damper can be reset. An access plate is provided.

When the damper is closed manually or if the fusible link melts and causes the damper to close, the fan and auto wash down are not affected.

When the damper closes due to activation of the thermostats, the fan[s] will shut OFF and the auto wash will actuate.

F. Air Make-Up [Supply] Plenums

Ventilators may be supplied with four [4] different Air-Make-up plenums. Air is controlled by grill registers or a special E-Z Breeze perforated panel.

1. Grill Registers [Refer to fig. 25]

Grill registers are located for external discharge or both internal and external discharge. Internal registers have fixed louvers for proper "Short Cycle" of air. External registers have four-way louvers for adjusting direction of air flow to suit job requirements. Grill registers have opposing blade dampers located on the rear of the

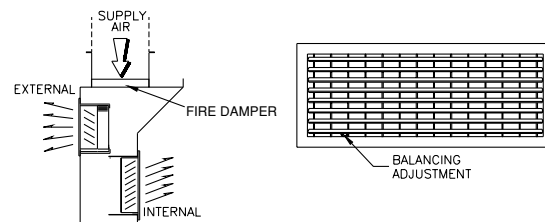

fig. 25

2. E-Z Breeze [Refer to fig. 26]

The E-Z Breeze plenum is specially designed to slow the velocity of the supply air to minimize the energy costs incurred for tempering the air. The front perforated panel is removable for cleaning. Screws are provided to secure the panel in place after cleaning.

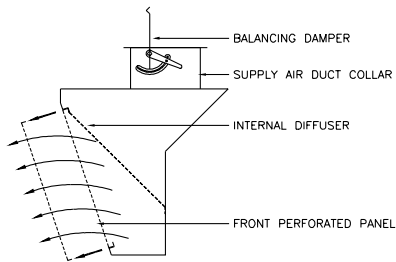

fig. 26

3. Slot-Type Internal Air Make-Up

Hoods provided with "Short-Cycle" type air make-up only are supplied with a slot which is designed to direct the air along the top of the hood and into the exhaust plenum inlet. The volume of air can be regulated through the use of a combination balancing damper and fire damper located on top of the air make-up plenum. [Refer to fig. 24]

G. Auto Wash

Plenum wash down is a feature of the Energy Aire Ventilator which eliminates the need to frequently clean the grease extraction area. The wash down cycle normally occurs immediately after the cooking period and does not occur while the fans are ON. A water/detergent mixture is sprayed from a series of nozzles to remove accumulated grease and grime which flows out through the drain. A vacuum breaker/check valve must be installed upstream of the detergent injection point [and a minimum of 6" higher than the ventilator inlet] to prevent detergent from backflowing into the building water supply. [Refer to fig. 14]. Hot water should be at 120°F and pressure must be between 20 psig and 40 psig flow. The duration of the wash down cycle is adjustable and will vary depending of length of cooking cycle, type of cooking equipment used, concentration of detergent, water pressure and temperature, among other considerations. See Sec. VI, b., "Setting the PAWS", for instructions.

**Note: See Page 28 cut sheet for detergent information.

H. Cold Water Mist [Optional]

To aid in extracting particulates from the exhausted air and to aid in cooling the exhaust, a cold water mist option is available. This is especially useful with charbroilers. Cold water mist is a fine spray within the

plenum area which runs whenever the fans are ON. This complements the baffle system on Energy Aire Systems and does not replace the wash down feature. Water pressure should be between 30-40 psig flow.

I. Lights

1. Surface Mounted - Incandescent

To replace the bulb unscrew the globe. Fixture will accept bulbs up to a maximum of 100 watts. Screw the bulb into the socket and then proceed to screw the globe tightly in position. Be sure that the inner silicone gasket is in place before installing the globe

2. Recessed - Incandescent

To replace the bulb, loosen screws which retain diffuser panel. Diffuser panel is attached to housing with a cable to prevent it from falling or becoming lost. Fixture will accept bulbs up to a maximum of 150 watts.

3. Recessed - Fluorescent

To replace bulbs, unscrew diffuser panel. The diffuser is attached to a housing with a cable to prevent it from falling or being lost. Two [2] bulbs are required for each fixture.

Fixture Size

[nominal]	Bulb Size
24"	[2] F20T12TS
36"	[2] F30T12RS
48"	[2] F40T12RS

VIII. PERIODIC MAINTENANCE

A. Baffle Filters

Filters should be removed and cleaned at least weekly, depending on hours of operation. Filters may be cleaned by soaking in a strong detergent solution, or running thru a dishwasher. When replacing, make sure filters and handles are running vertically, and filters are seated properly, refer to Sec. VII, A.1, pg. 15.

B. Modular Grease Extractors

Modules should be removed and cleaned at least weekly, depending on hours of operation. Modules may be cleaned with a brush and a strong detergent solution, or run thru the dishwasher. When replacing modules, make sure they are seated properly, refer to Sec. VII, B.1, pg. 16.

C. Grease Trough

Should be checked weekly for grease build up, and cleaned with strong detergent, if necessary.

D. Grease Collection Receptacle

Should be emptied at least once a day, and cleaned daily with a strong detergent.

E. Hood Canopy

1. Inside hood canopy should be wiped down as needed. The area at the exhaust intake openings should be wiped down daily.

2. Inspect inside of extraction chamber at least monthly, to insure proper cleaning and that the trough is free of foreign matter.

F. Detergent System

1. Detergent tank should be checked at least weekly; and cleaned every six months. Always keep cover on tight to prevent spillage and evaporation.

2. A colloid type detergent, is recommended due to its non-caustic, non-toxic, biodegradable characteristics. It will not damage the rubber or synthetic parts of the pumping system. AVTEC recommends using EVAC Detergent. Available thru your local Service Agents or call Factory. See page 28 for more information.

3. All fittings should be checked for air tightness at least monthly.

4. Foot check valve should be cleaned every six months.

G. Fusible Link Replacement

1. Blade Type [Refer to fig. 27]

Exhaust damper fusible links are rated at 350°F [P/N AS LNK0302] and Air Make-up damper fusible links are rated at 286°F [P/N AS LNK0303]. Fusible links shall be replaced at least annually per NFPA 96, 8-2.1.2. New "S" hooks [P/N FA HOK0301] should be used whenever the fusible links are replaced.

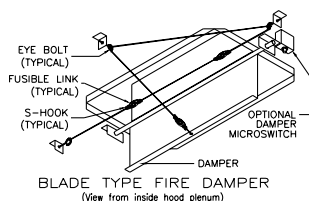
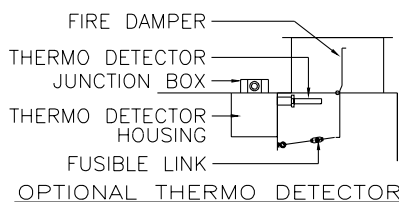

Cable tension can be adjusted by moving the eye-bolts in and out to ensure that the damper is fully open.

fig. 27

2. Curtain Type [Refer to fig. 28]

When make-up air is brought directly into the capture area a fire damper is required at the duct collar. The curtain damper is equipped with a 212°F fusible link [P/N AS LNK0006]. Fusible links shall be replaced at least annually per NFPA 96, 8-2.1.2. New "s" hooks [P/N FA HOK0301] should be installed whenever the fusible links are replaced. These links are replaced by unfolding the retaining strap and removing the clover hook and fusible link as a unit. Be careful to hold the curtain damper in place as a spring will try to pull it closed.

fig. 28

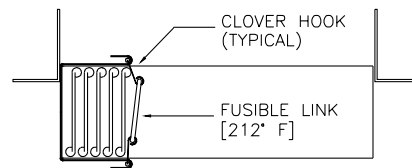

AIR MAKE-UP CURTAIN DAMPER

IX. PARTS LIST

A. PAWS PANEL - ELECTRICAL

ITEM NO.	AVTEC PART NO.	DESCRIPTION
1	112-0301	Fuse Block Bracket
2	EL BLK0306	Terminal Brass Screws
3	EL BLK0307	Terminal Trac
4	EL BLK0308	End Stop for 200-1018
5	EL FUS0304	Fuse [SC-15]
6	EL BLK0315	Fuse Block [Holder]
7	EL SEN0305	Low Level Sensor [Detergent] PC Board
8	EL SWT0318	Flush Toggle Switch
9	EL STA0301	Pull Station [Yellow]
10	EL HRN0301	Sonalert Horn
11	EL ASV0303	PAWS Assembly Model P10 & P20
12	EL TER0301	Output Term for Converting MAF/PAWS Assembly
13	EL RLY0317	Output Relay for Converting MAF/PAWS Assembly
14	PP LBL0302	PAWS Faceplate w/slot Silkscreen/Acrylic
15	PP LBL0303	PAWS Faceplate no slot Silkscreen/Acrylic
16	RP PRB0601	Detergent Probe Cut to Length

B. VCW PANEL - ELECTRICAL

ITEM NO.	AVTEC PART NO.	DESCRIPTION
1	EL CNT0302	Terminal Block Section
2	EL CNT0348	Terminal Section End Stop
3	EL SWT0348	Push Button w/Black Cap, Start Fan
4	EL SWT0351	Push Button w/Red Cap, Start Wash
5	EL BLK0323	Normally Open Contact Block [For part no. EL SWT0348 & EL SWT0351]
6	EL SWT0318	Light Switch [20a]
7	EL STA0301	Fire Switch [Pull Station]
8	EL RLY0315	Relay Socket [For part no. EL TMR0312]
9	EL TMR0312	Omnetics Timer Relay]

C. PAWS/VCW PANEL - PLUMBING

ITEM NO.	AVTEC PART NO.	DESCRIPTION
1	HD TNK0301	5 gal. Detergent Tank
2	HD TNK0302	2 gal. Detergent Tank
3	PB SOL0301	1/2" Water Solenoid
4	PB SOL0302	3/4" Water Solenoid
5	PB SOL0303	1" Water Solenoid
6	PB SOL0304	1-1/4" Water Solenoid
7	PB SOL0305	1-1/2" Water Solenoid
8	PB VLV500	1/2" Ball Valve
9	PB VLV756	3/4" Ball Valve
10	PB VLV750	1" Ball Valve
11	PB VLV790	1-1/4" Ball Valve
12	PB VLV0306	1-1/2" Ball Valve
13	PB VLV0311	1" Supervised Shut-Off Valve [Water]
14	PB VLV0312	1-1/4" Supervised Shut-Off Valve [Water]

16	PB VLV0313	1-1/2" Supervised Shut-Off Valve [Water]
17	PB VLV0302	1/2" Check Valve, Br.
18	PB VLV0303	3/4" Check Valve, Br.
19	PB VLV0304	1" Check Valve, Br.
20	PB VLV0332	3/8" Check Valve, Br.
21	600-1104	1/4" Check Valve, Br.
22	PB VLV0305	1-1/4" Check Valve, Br.
23	PB VLV0316	1-1/2" Check Valve, Br.
24	HD STN0303	1/2" Wye [Line] Strainer, B.I.
25	PB WYE0301	3/4" Wye [Line] Strainer, B.I.
26	PB STN0306	1" Wye [Line] Strainer, B.I.
27	PB WYE0302	1-1/4" Wye [Line] Strainer, B.I.
28	HD STN0305	1-1/2" Wye [Line] Strainer, B.I.
29	PB SUP0301	1/2" Shock Arrestor
30	HD GGE0303	1/2" Press/Temp. Gauge
31	PB BRK0301	1/2" Vacuum Breaker, Br.
32	PB BRK0305	3/4" Vacuum Breaker, Br.
33	PB BRK0302	1" Vacuum Breaker, Br.
34	PB BRK0306	1-1/4" Vacuum Breaker, Br.
35	PB BRK0312	1-1/2" Vacuum Breaker, Br.
36	PB VLV0317	3/4" Pressure Reducing Valve
37	PB VLV0326	1" Pressure Reducing Valve
38	PB VLV0403	1-1/4" Pressure Reducing Valve
39	HD PMP0301	Single Head Diaphragm Pump [Detergent]
40	HD PMP0303	Foot Valve
41	PB VLV0342	Check Anti-Syphon Valve

D. EVAC DETERGENT

ITEM NO.	PART NO.	DESCRIPTION
1	FL DET0302	EVAC 1 Gallon
2	FL DET0303	EVAC 5 Gallon

E. ELECTRO - MECHANICAL DAMPER

ITEM NO.	AVTEC PART NO.	DESCRIPTION
1	FA SCW0301	1-1/2" S/S Spring
2	HD SPR0303	Damper Spring [Right]
3	HD SPR0304	Damper Spring [Left]
4	HD SPR0306	Solenoid Return Spring
5	HD KNB0301	Red Knob [Damper]
6	EL CNT0323	Terminal Section
7	EL CNT0348	Terminal Section End Stop
8	EL RLY0311	Fire Relay [Damper]
9	HD SOL0313	Damper Solenoid
10	EL SWT 0323	300°F, Normally Open Thermoswitch
11	411-0226	Electro-Mechanical Damper Instruction [Label]
12	HD BOT0301	Convolution Boot
13	AS ASY0301	AW Damper Linkage Assembly Complete
14	AS LNK0302	350°F, Fusible Link
15	AS CBL0301	Stainless Steel Cable
16	AS SLV0301	Crimp Sleeve (For S.S. Cable)

17	144-0901	Small Linkage (Between 306-0000 and 144-0902)
18	144-0902	Large Linkage

F. FUSIBLE LINK DAMPER

ITEM NO.	AVTEC PART NO.	DESCRIPTION
1	AS DMP1010B	10" x 10" Balancing Damper
2	AS DMP1610B	16" x 10" Balancing Damper
3	AS DMP2010B	20" x 10" Balancing Damper
4	AS DMP3010B	30" x 10" Balancing Damper
5	AS DMP4010B	40" x 10" Balancing Damper
6	AS DMP1010C	10" x 10" Combo Balancing and Fire Damper
7	AS DMP1610C	16" x 10" Combo Balancing and Fire Damper
8	AS DMP2010C	20" x 10" Combo Balancing and Fire Damper
9	AS DMP3010C	30" x 10" Combo Balancing and Fire Damper
10	AS DMP4010C	40" x 10" Combo Balancing and Fire Damper
11	AS LNK0302	Fusible Link 350°F
12	FA BLT0303	Eye Bolt 3/16" x 2" - 10 - 24
13	FA HOK0301	"S" Hook
14	AS CBL0301	Stainless Steel Cable
15	AS SLV0301	Crimp Sleeve [for S/S Cable]
16	AS LNK0303	Fusible Link 286°F
17	AS LNK0201	Fusible Link 212°F
18	306-0007	Clover Hook [Curtain Damper]

G. HOOD CANOPY

ITEM NO.	AVTEC PART NO.	DESCRIPTION
1	HD LCH0304	Paddle Latch
2	HD LCH0307	"Vice Action" Panel Latch
3	AS FLT1616SSR	16" x 16" S/S Filter
4	AS FLT2025SSR	20" x 25" S/S Filter
5	AS FLT2020SSR	20" x 20" S/S Filter
6	AS FLT2020ALR	20" x 20" Aluminum Filter
7	AS FLT1616ALR	16" x 16" Aluminum Filter
8	HD HGR0301	Hanger Bracket [Ventilator]
9	AS FLT1620SSR	16" x 20" S/S Filter
10	AS FLT1620ALR	16" x 20" Aluminum Filter
11	AS FLT2016ALR	20" x 16" Aluminum Filter
12	AS FLT2025ALR	20" x 25" Aluminum Filter
13	AS FLT2016SSR	20" x 16" S/S Filter
14	AS GLB0201	Incandescent Work Light Globe
15	AS FXT0301	Incandescent Work Light Cage
16	AS LGT0001	Incandescent Work Light Base
17	AS LGT1220	3'-0" Fluorescent Work Light
18	AS LGT1420	4'-0" Fluorescent Work Light
19	AS LGT1020	2'-0" Fluorescent Work Light
20	AS LGT9901	Recessed Incandescent Work Light
21	AS NZL0302	Spray Nozzle, Br. No. 1/8 B-0.5-0.5W [Cold Water Mist]
22	AS NZL0303	Spray Nozzle, Br. No. 1/8 GG-2.8W]Water
23	AS NZL0304	Spray Nozzle, Br. No. 1/8 GGA-1.5W]Wash
24	PB CPL0316	2" Expandable Coupler
25	PB ADP0310	2" PVC XMPT Adapter
26	PB FTG0311	2" Male PVC Fitting



Cleaner/Degreaser

For Exhaust Ventilator Auto-wash Cleaner

Cleaner/Degreaser

Advantages

UNIQUE, POWERFUL CLEANING FORMULA

- Tough enough to break down the worst oil and grease in your water wash system...leaving it Super Clean!
- Reduces the need for using environmentally harmful chemicals
- Non-caustic and non-abrasive
- Concentrated formula gives you more cleaning power for your money!
- Compatible with bio-enzyme wastewater treatment products like TDW Grease Treatment
- Exclusive factory detergent pump warranty
- Can be used in all water-wash ventilators.

Certified Biodegradable

EVAC Cleaner/Degreaser is certified biodegradable by Scientific Certification Systems (SCS), an independent organization. SCS has established some of the nation's strictest standards for environmental performance.

Formulas at your fingertips

In order to achieve **maximum economy** in the maintenance of your water-wash system, **EVAC Cleaner/Degreaser** can be diluted. Following are some suggested dilutions:

COOKING TYPE	DILUTION SUGGESTED
Medium daily cooking	1 part EVAC : 2 parts water
Heavy daily cooking (No Charbroilers/solid fuel use)	1 part EVAC : 1 part water
Heavy daily cooking Charbroiling Solid fuel cooking	Use Concentrate

Note: There are multiple combinations of dilution, wash cycle length, frequency of washes, water temperature, and mechanical options possible for most systems. Consult experienced distributor/service agents for information regarding the best program for your institution.



AVAILABLE IN
**1/2 GALLON, 1 GALLON, 5 GALLON,
30 GALLON AND 55 GALLON DRUMS**

Ask your Authorized Service Agency for these part numbers

FL DET 0301	1/2 GALLON
FL DET 0302	1 GALLON
FL DET 0303	5 GALLON

AIR MOVEMENT RECORDINGS

(Supplement to Ventilator Installation/Start Up Report)

Project Name	
---------------------	--

SECTION NO. _____	ITEM NO. _____	MODEL NO. _____	SLOT DIMEN. a " b "	EXHAUST SUPPLY
READING NO.	POSITION NO. 1	POSITION NO. 2	POSITION NO. 3	POSITION NO. 4
1				
2				
3				
TOTAL				
AVERAGE				

SECTION NO. _____	ITEM NO. _____	MODEL NO. _____	SLOT DIMEN. a " b "	EXHAUST SUPPLY
READING NO.	POSITION NO. 1	POSITION NO. 2	POSITION NO. 3	POSITION NO. 4
1				
2				
3				
TOTAL				
AVERAGE				

SECTION NO. _____	ITEM NO. _____	MODEL NO. _____	SLOT DIMEN. a " b "	EXHAUST SUPPLY
READING NO.	POSITION NO. 1	POSITION NO. 2	POSITION NO. 3	POSITION NO. 4
1				
2				
3				
TOTAL				
AVERAGE				

SECTION NO. _____	ITEM NO. _____	MODEL NO. _____	SLOT DIMEN. a " b "	EXHAUST SUPPLY
READING NO.	POSITION NO. 1	POSITION NO. 2	POSITION NO. 3	POSITION NO. 4
1				
2				
3				
TOTAL				
AVERAGE				

SECTION NO. _____	ITEM NO. _____	MODEL NO. _____	SLOT DIMEN. a " b "	EXHAUST SUPPLY
READING NO.	POSITION NO. 1	POSITION NO. 2	POSITION NO. 3	POSITION NO. 4
1				
2				
3				
TOTAL				
AVERAGE				

SECTION NO. _____	ITEM NO. _____	MODEL NO. _____	SLOT DIMEN. a " b "	EXHAUST SUPPLY
READING NO.	POSITION NO. 1	POSITION NO. 2	POSITION NO. 3	POSITION NO. 4
1				
2				
3				
TOTAL				
AVERAGE				

Readings Taken by: _____

A. ENERGY AIRE HOODS - EXHAUST

1. Reading No. 1, 2, and 3 are taken at the front middle, and back of the intake slot.
2. For 8 foot hood sections and less, take three [3] readings at each of three [3] locations: 1 foot from each end, and one [1] reading in the middle.
3. For hood sections over 8 feet in length, take three [3] readings at each of four [4] locations: 1 foot from each end, and two [2] readings in the middle.

4. B. FILTER HOODS - EXHAUST

1. Take Reading No. 1, 2, and 3 on vertical centerlines.
2. Refer to A.2, 3.

C. SUPPLY PLENUM

1. Reading No. 1 only is used.
2. Take readings on horizontal centerline of grill.
3. Refer to A.2, 3, but only one reading at each location

AVTEC INDUSTRIES INC. 1055 MENDELL DAVIS DR. JACKSON, MS 39272 [888] 994-7636

form no. 14018 1998 AVTEC Industries inc.

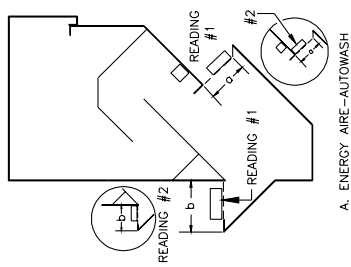

A. ENERGY AIR-AUTOWASH

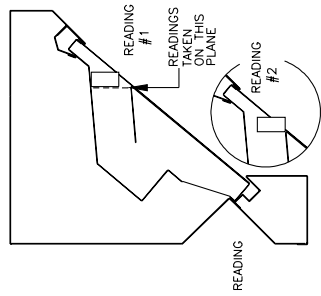

B. ENERGY AIR-MODULAR

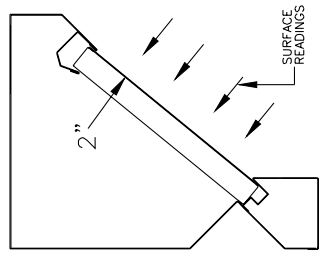

C. BAFFLE FILTER

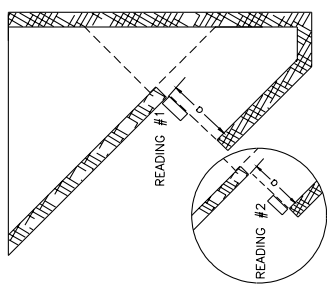

D. SUPPLY PLENUM (INTERNAL)

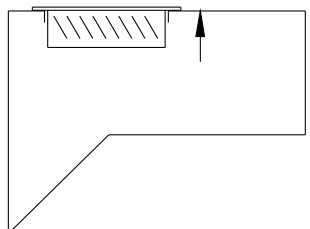

E. SUPPLY PLENUM (EXTERNAL)

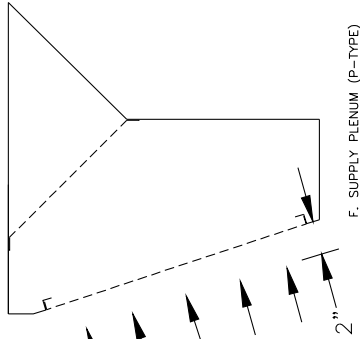

F. SUPPLY PLENUM (P-TYPE)

DATE	SCALE	TITLE
03-11-97	N/A	CALCULATING AND RECORDING AIR MOVEMENT READINGS
DWG. NO. VTMNAIR.DWG		
DRAWN BY C. STYLES	MODEL NO. AX**, AW**, AF**, **P, **I, **E	Figure No. A. 3.

CALCULATING AND RECORDING AIR MOVEMENT

- 1.) Cubic feet per minute or **CFM'S** is the total area multiplied by the average feet per minute.

$$A: \frac{\text{CFM}}{\text{AREA} \quad | \quad \text{FPM}}$$

$$\begin{aligned} B: \text{CFM} &= \text{AREA} \times \text{AVG. FPM} \\ \text{FPM} &= \text{CFM} \div \text{AREA} \\ \text{AREA} &= \text{CFM} \div \text{FPM} \end{aligned}$$

- 2.) **AREA** is the length of the opening multiplied by the width in inches. Divide the total by 144 to get the total square feet (area).

EXHAUST

- A: **Filter Hoods** - Area = *Square Feet x Quantity of Filters
* 16 x 20 Filter = 1.75 Square Feet
* 20 x 20 Filter = 2.25 Square Feet

- B: **Extractor Type Hoods** - Area = **Square Feet x Quantity of Modules

16" Standard Module

- **Low Volume Extractor w/3" Slot = .32352 Square Feet
**High Volume Extractor w/4" Slot = .43136 Square Feet

9" Standard Module

- **Low Volume Extractor w/3" Slot = .1855 Square Feet
**High Volume Extractor w/4" Slot = .2473 Square Feet

- C: **Water Wash Hood** - Area = Length of Slot x Width of Slot in inches and divided by 144 for square feet.

SUPPLY

- A: Perforated Supply Air Panels - Square Feet of Panel x .4 = Area.

- B: Register Type Supply Air Panels - Square Feet of Panel x .7 = Area.

NOTE: AVTEC INDUSTRIES recognizes readings taken at the surface and not at the duct opening. Please refer to the Air Movement Recording Worksheet for proper location(s) to take readings.

WARRANTY-

AVTEC INDUSTRIES INC. warrants to the original purchaser for use of our products, that any part thereof which proves to be defective in material or workmanship under normal use within one year from date of installation, will be replaced free of charge, labor to replace such part is warranted for one year from installation. All warranty labor to be performed during regular working hours, with no overtime premium.

All Warranty service must be authorized by the factory and be performed by AVTEC's authorized service personnel.

This Warranty is limited to the United States and Canada.

This Warranty does not apply to any damage resulting from shipping, improper installation, accident, unauthorized alteration, local codes not previously brought to the attention of AVTEC, misuse, or abuse; and does not cover loss of food, other products or damage to equipment or property resulting from mechanical or electrical failure.

AVTEC neither makes nor assumes and does not authorize any other person to assume any other obligation or liability in connection with its products other than that covered in this Warranty.