



INSTALLATION INSTRUCTIONS

DIRECT VENT 500/600/800 SERIES

RETAIN THESE INSTRUCTIONS FOR FUTURE REFERENCE

VENTED GAS FIREPLACE HEATERS - DIRECT VENT MODELS
P/N 700,005M REV. X 11/2004

MODELS

This appliance may be installed in an aftermarket permanently located, manufactured home (USA only) or mobile home, where not prohibited by local codes. This appliance is only for use with the type of gas indicated on the rating plate. This appliance is not convertible for use with other gases, unless a certified kit is used.

Millivolt Models

D-500CMN	DT-600CMP
D-500CMP	DR-600CMN
DT-500CMN	DR-600CMP
DT-500CMP	D-800CMN
DR-500CMN	D-800CMP
DR-500CMP	DT-800CMN
D-600CMN	DT-800CMP
D-600CMP	DR-800CMN
DT-600CMN	DR-800CMP

Electronic Models

D-500CEN	DT-600CEP
D-500CEP	DR-600CEN
DT-500CEN	DR-600CEP
DT-500CEP	D-800CEN
DR-500CEN	D-800CEP
DR-500CEP	DT-800CEN
D-600CEN	DT-800CEP
D-600CEP	DR-800CEN
DT-600CEN	DR-800CEP

WARNING: IF THE INFORMATION IN THIS MANUAL IS NOT FOLLOWED EXACTLY, A FIRE OR EXPLOSION MAY RESULT CAUSING PROPERTY DAMAGE, PERSONAL INJURY OR LOSS OF LIFE.

FOR YOUR SAFETY: Do not store or use gasoline or other flammable vapors or liquids in the vicinity of this or any other appliance.

FOR YOUR SAFETY: What to do if you smell gas:

- DO NOT light any appliance.
- DO NOT touch any electrical switches.
- DO NOT use any phone in your building.
- Immediately call your gas supplier from a neighbor's phone. Follow your gas suppliers instructions.
- If your gas supplier cannot be reached, call the fire department.

Installation and service must be performed by a qualified installer, service agency or the gas supplier.

AVERTISSEMENT: ASSUREZ-VOUS DE BIEN SUIVRE LES INSTRUCTIONS DONNÉ DANS CETTE NOTICE POUR RÉDUIRE AU MINIMUM LE RISQUE D'INCENDIE OU POUR ÉVITER TOUT DOMMAGE MATÉRIEL, TOUTE BLESSURE OU LA MORT.

POUR VOTRE SÉCURITÉ: Ne pas entreposer ni utiliser d'essence ni d'autre vapeurs ou liquides inflammables dans le voisinage de cet appareil ou de tout autre appareil.

POUR VOTRE SÉCURITÉ: Que faire si vous sentez une odeur de gaz:

- Ne pas tenter d'allumer d'appareil.
- Ne touchez à aucun interrupteur. Ne pas vous servir des téléphones se trouvant dans le bâtiment où vous vous trouvez.
- Evacuez la pièce, le bâtiment ou la zone.
- Appelez immédiatement votre fournisseur de gaz depuis un voisin. Suivez les instructions du fournisseur.
- Si vous ne pouvez rejoindre le fournisseur de gaz, appelez le service des incendies.

L'installation et service doit être exécuté par un qualifié installateur, agence de service ou le fournisseur de gaz.



OMNI-Test Laboratories, Inc.

OTL Report No. 116-F-13-4

TABLE OF CONTENTS

Packaging	page 2
Introduction	page 2
General Information	page 2
Location	page 3
Appliance and Vent Clearances	page 4
Vent Termination Clearances	page 5
Typical Installation Sequence	page 5
Detailed Installation Steps	page 5
Step 1. Framing	page 5
Step 2. Routing Gas Line	page 5
Fireplace Specifications	page 8
Step 3. Install the Vent System	page 9
Vertical Termination Systems	page 10
Vent Section Length Chart	page 10
Vertical Vent Tables and Figures	page 13
Horizontal Termination System	page 15
Horizontal Vent Tables and Figures	page 17
Venting Using Flexible Vent Pipe	page 20
Step 4. Field Wiring	page 21
Step 5. Optional Blower Kit Wiring	page 21
Step 6. Connecting Gas Line	page 22
Step 7. Installing Logs	page 22
Step 8. Checking Unit Operation	page 22
Step 9. Installing Glass Door	page 23
Step 10. Burner Adjustments	page 23
Step 11. Hood Installation	page 23
Finishing Requirements	page 23
Cold Climate Insulation	page 24
Installation Accessories	page 25
Gas Conversion Kits	page 26

This installation manual will help you obtain a safe, efficient, dependable installation for your appliance and vent system.

Please read and understand these instructions before beginning your installation.



We suggest that our gas hearth products be installed and serviced by professionals who are certified in the U.S. by the National Fireplace Institute® (NFI) as NFI Gas Specialists.

PACKAGING

The assembled vented gas fireplace heater is packaged with:

- 1 - one log set located in firebox area.
- 2 - one envelope containing the literature package which consists of the homeowner's manual, installation instructions, log set supplement and warranty; envelope is located in the control area.
- 3 - one vent restrictor to be applied as shown on **page 9**; restrictor is taped to the envelope.
- 4 - one hood located behind the top panel.
- 5 - one bag of decorative volcanic stone located in the control area.
- 6 - one bag of glowing embers located in the control area.

INTRODUCTION

These vented gas fireplace heaters are sealed combustion, air circulating gas fireplaces designed for residential applications. These appliances must be installed with the **Secure Vent™** and /or **Secure Flex™** vent systems routed to the outside atmosphere.

Millivolt appliances are designed to operate on natural or propane gas. A millivolt gas control valve with piezo ignition system provides safe, efficient operation. External electrical power is required to operate the optional blower if installed in these units.

Electronic appliances are designed to operate on natural or propane gas. An electronic intermittent pilot ignition system provides safe, efficient operation. External electrical power is required to operate these units.

These appliances comply with National Safety Standards and are tested and listed by Omni-Test Laboratories (Report No. 116-F-13-4) to ANSI Z21.88-2002 (in Canada, CSA-2.33-2002), and CAN/CGA-2.17-M91 in both USA and Canada, as vented gas fireplace heaters.

Both millivolt and electronic versions of these appliances are listed by Omni-Test Laboratories for installation in bedrooms and mobile homes.

Installation must conform to local codes. In the absence of local codes, installation must comply with the current National Fuel Gas Code, ANSI Z223.1. (In Canada, the current CAN-1 B149 installation code.) Electrical wiring must comply with the National Electrical Code ANSI/NFPA 70 - (latest edition). (In Canada, the current CSA C22-1 Canadian Electrical Code.)

DO NOT ATTEMPT TO ALTER OR MODIFY THE CONSTRUCTION OF THE APPLIANCE OR ITS COMPONENTS. ANY MODIFICATION OR ALTERATION MAY VOID THE WARRANTY, CERTIFICATION AND LISTINGS OF THIS UNIT.

GENERAL INFORMATION

Note: Installation and repair should be performed by a qualified service person. The appliance should be inspected annually by a qualified professional service technician. More frequent inspections and cleanings may be required due to excessive lint from carpeting, bedding material, etc. It is imperative that the control compartment, burners and circulating air passage ways of the appliance be kept clean.

S'assurer que le brûleur et le compartiment des commandes sont propres. Voir les instructions d'installation et d'utilisation qui accompagnent l'appareil.

Provide adequate clearances around air openings and adequate accessibility clearance for service and proper operation. Never obstruct the front openings of the appliance.

These appliances are designed to operate on natural or propane gas only.

TYPICAL INSTALLATION

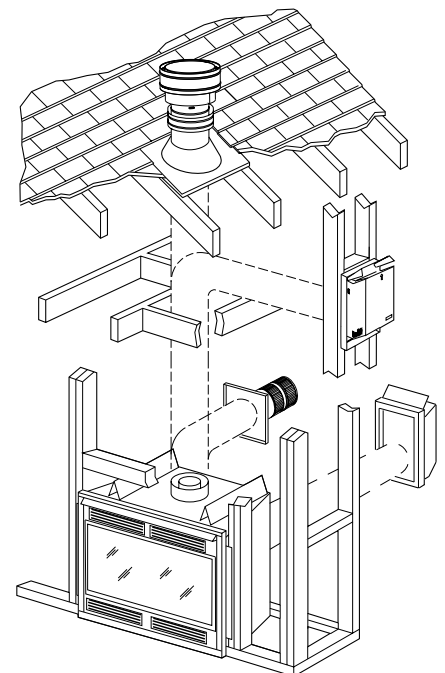

Figure 1

Millivolt Models -

Millivolt models come standard with the manually-modulated gas valve; flame appearance and heat output can be controlled at the gas valve.

Input of millivolt models is shown in the following table:

Millivolt Models with Manually-Modulated Gas Valve			
Natural Gas		Propane Gas	
D, DT, DR Series	Input rate (BTU/H)	D, DT, DR Series	Input rate (BTU/H)
500	17,500 to 23,000	500	17,500 to 23,000
600	21,500 to 29,000	600	22,500 to 29,000
800	24,000 to 32,000	800	25,500 to 32,000

Electronic Models -

Electronic models have a fixed rate gas valve. Input of electronic models is shown in the following table:

Electronic Models with Fixed-Rate Gas Valve	
Natural and Propane Gas	
D, DT, DR Series	Input rate (BTU/H)
500	23,000
600	29,000
800	32,000

All Models -

Maximum manifold pressure is 3.5 in. w.c. (0.87 kPa) for natural gas and 10 in. w.c. (2.49 kPa) for LP/Propane gas.

Installations at Altitudes of 0 to 4500 ft.- Units are tested and approved for elevations of 0 to 4500 feet (0 to 1372 meters).

Installations at Altitudes above 4500 ft.- For elevations above 4500 feet (1372 meters), install the unit according to the regulations of the local authorities having jurisdiction and, in the USA, the latest edition of the National Fuel Gas Code (ANSI Z223.1) or, in Canada, the latest edition of the CAN1-B149.1 and .2 codes.

Table 1 shows the units' gas orifice size for the elevations indicated.

D, DT, DR Series	Orifice size		Elevation Feet (meters)
	Nat.	Prop.	
500	0.090 in.	#54	0-4500 (0-1370)
600	#36	#52	
800	#33	0.065 in.	

Table 1

The millivolt appliances are manually controlled and feature a spark ignitor (piezo) that allows the appliance's pilot gas to be lit without the use of matches or batteries. This system provides continued service in the event of a power outage.

Do not use these appliances if any part has been under water. Immediately call a qualified, professional service technician to inspect the appliance and to replace any parts of the control system and any gas control which have been under water.

Ne pas se servir de cet appareil s'il a été plongé dans l'eau, complètement ou en partie. Appeler un technicien qualifié pour inspecter l'appareil et remplacer toute partie du système de contrôle et toute commande qui ont été plongés dans l'eau.

This appliance may be installed in an aftermarket permanently located, manufactured home (USA only) or mobile home, where not prohibited by local codes. This appliance is only for use with the type of gas indicated on the rating plate. This appliance is not convertible for use with other gases, unless a certified kit is used.

Cet appareil peut être installé dans un maison préfabriquée (É.-U. seulement) ou mobile déjà installée à demeure si les règlements locaux le permettent.

Cet appareil doit être utilisé uniquement avec les types de gaz indiqués sur la plaque signalétique. Ne pas l'utiliser avec d'autres gaz sauf si un kit de conversion certifié est installé.

Test gage connections are provided on the front of the millivolt gas control valve (identified IN for the inlet and OUT for the manifold side). A 1/8" NPT test gage connection is provided at the inlet and outlet side of the electronic gas control valve.

Minimum inlet gas pressure to these appliances is 5.0 inches water column (1.24 kPa) for natural gas and 11 inches water column (2.74 kPa) for propane for the purpose of input adjustment.

Maximum inlet gas supply pressure to these appliances is 10.5 inches water column (2.61 kPa) for natural gas and 13.0 inches water column (3.23 kPa) for propane.

These appliances must be isolated from the gas supply piping system (by closing their individual manual shut-off valve) during any pressure testing of the gas supply piping system at test pressures equal to or less than 1/2 psig (3.5 kPa).

These appliances and their individual shut-off valves must be disconnected from the gas supply piping system during any pressure testing of that system at pressures in excess of 1/2 psig (3.5 kPa).

These appliances must not be connected to a chimney or flue serving a separate solid fuel burning appliance.

Carbon Monoxide Poisoning: Early signs of carbon monoxide poisoning are similar to the flu with headaches, dizziness and/or nausea. If you have these signs, obtain fresh air immediately. Turn off the gas supply to the appliance and have it serviced by a qualified professional, as it may not be operating correctly.

WARNING: FAILURE TO COMPLY WITH THE INSTALLATION AND OPERATING INSTRUCTIONS PROVIDED IN THIS DOCUMENT WILL RESULT IN AN IMPROPERLY INSTALLED AND OPERATING APPLIANCE, VOIDING ITS WARRANTY. ANY CHANGE TO THIS APPLIANCE AND/OR ITS OPERATING CONTROLS IS DANGEROUS. IMPROPER INSTALLATION OR USE OF THIS APPLIANCE CAN CAUSE SERIOUS INJURY OR DEATH FROM FIRE, BURNS, EXPLOSION OR CARBON MONOXIDE POISONING.

WARNING: CHILDREN AND ADULTS SHOULD BE ALERTED TO THE HAZARDS OF HIGH SURFACE TEMPERATURES. USE CAUTION AROUND THE APPLIANCE TO AVOID BURNS OR CLOTHING IGNITION. YOUNG CHILDREN SHOULD BE CAREFULLY SUPERVISED WHEN THEY ARE IN THE SAME ROOM AS THE APPLIANCE.

WARNING: DO NOT PLACE CLOTHING OR OTHER FLAMMABLE MATERIALS ON OR NEAR THIS APPLIANCE.

AVERTISSEMENT: SURVEILLER LES ENFANTS. GARDER LES VÊTEMENTS, LES MEUBLES, L'ESSENCE OU AUTRES LIQUIDES À VAPEUR INFLAMMABLES À CÔTÉ DE L'APPAREIL.

LOCATION

In selecting the location, the aesthetic and functional use of the appliance are primary concerns. However, vent system routing to the exterior and access to the fuel supply are also important. Consideration should be given to traffic ways, furniture, draperies, etc., due to elevated surface temperatures (*see Figure 2*).

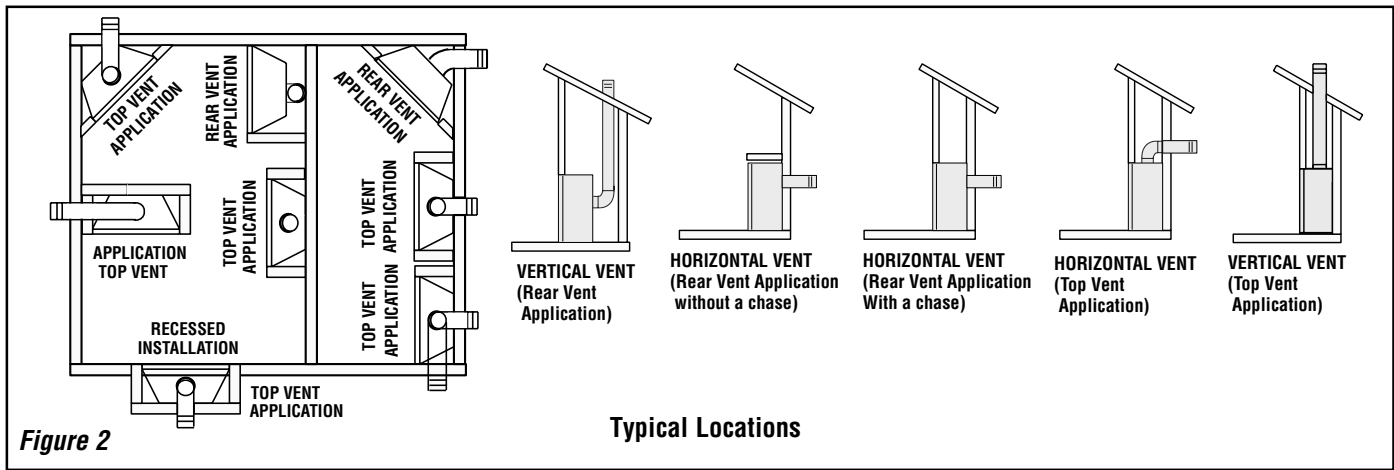

The location should also be free of electrical, plumbing or other heating/air conditioning ducting. These direct vent appliances are uniquely suited for installations requiring a utility shelf positioned directly above the fireplace. Utility shelves like these are commonly used for locating television sets and decorative plants.

To provide for the lowest possible shelf surface use the alternate rear vent outlet with attached venting routed in a way to minimize obstructions to the use of the space above the appliance. **Do not insulate the space between the appliance and the area above it.** See Figure 3. The minimum height from the base of the appliance to the underside of combustible materials used to construct a utility shelf in this fashion is shown in the table in Figure 3.

The appliance should be mounted on a fully supported base extending the full width and depth of the unit. The appliance may be located on or near conventional construction materials. However, if installed on combustible materials, such as carpeting, vinyl tile, etc., a metal or wood barrier covering the entire bottom surface must be used.

APPLIANCE AND VENT CLEARANCES

These appliances are approved with zero clearance from spacers to combustible materials on all sides (as detailed in Table 2), with the following exception: When the unit is installed with one side flush with a perpendicular side wall, the wall perpendicular to the opposite side of the appliance front face must not extend more than five inches beyond the front edge of the unit. In addition, when the unit is recessed, the side walls surrounding the unit must not extend more than five inches beyond the front edge of the unit. Refer to Figure 2.

Model No.	Shelf Height inches (mm)			
	Top Vent - with One 90 Degree Elbow		Rear Vent - Straight Out the Back	
	Secure Vent	Secure Flex	Secure Vent	Secure Flex
D-500	46 1/8 (1172)	47 7/8 (1216)	35 1/4 (895)	35 1/4 (895)
DT-500	46 1/8 (1172)	47 7/8 (1216)	N/A	N/A
DR-500	N/A	N/A	35 1/4 (895)	35 1/4 (895)
D-600, D-800	51 1/8 (1298)	52 7/8 (1343)	40 1/4 (1022)	40 1/4 (1022)
DT-600, DT-800	51 1/8 (1298)	52 7/8 (1343)	N/A	N/A
DR-600, DR-800	N/A	N/A	40 1/4 (1022)	40 1/4 (1022)

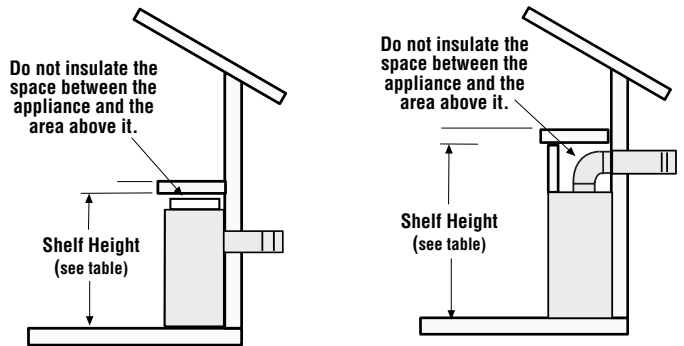

Figure 3 Shelf Above Fireplace With Rear Venting Shelf Above Fireplace With Top Venting

BACK	1/2 in. (13 mm) 0 in. (0 mm) spacers
SIDES	1/2 in. (13 mm)** 0 in. (0 mm) spacers
TOP SPACERS	0 in. (0 mm)
FLOOR	0 in. (0 mm)
From Bottom of Unit to Ceiling	64 in. (1626 mm)
VENT	1 in. (25.4 mm)*
SERVICE CLEARANCES	
FRONT	3 Feet. (0.9 meters)

*Note: 3 in. (75 mm) above any horizontal/inclined vent component.

**Note: The nailing flange and the cabinet surfaces directly adjacent to the framing member attached to the nailing flange, are exempt from the 1/2" clearance to combustibles defined for the rest of the cabinet sides and back.

Table 2

NOTE: DIAGRAMS & ILLUSTRATIONS NOT TO SCALE.

VENT TERMINATION CLEARANCES

These instructions should be used as a guideline and do not supersede local codes in any way. Install vent according to local codes, these instructions, the current National Fuel Gas Code (ANSI-Z223.1) in the USA or the current standards of CAN/CGA-B149.1 and -B149.2 in Canada.

Vertical Vent Termination Clearances

Terminate single vent caps relative to building components according to **figure 4**.

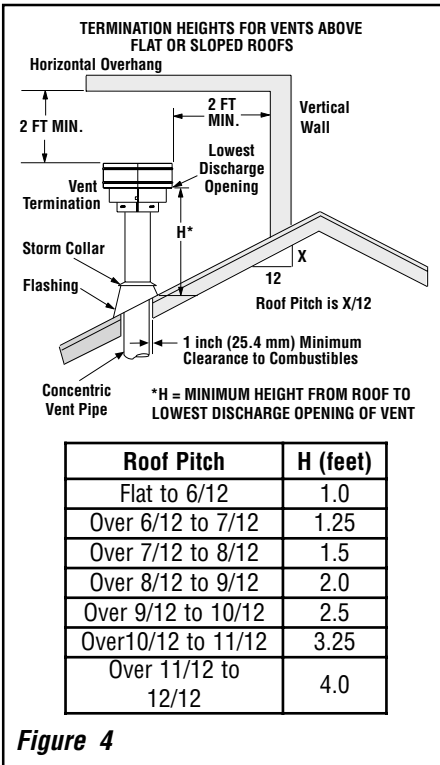

Terminate multiple vent terminations according to the installation codes listed at the top of this page.

Horizontal Vent Termination Clearances

The horizontal vent termination must have a minimum of 3" (76 mm) clearance to any overhead combustible projection of 2 1/2" (64 mm) or less. See **Figure 5**. For projections exceeding 2 1/2" (64 mm), see **Figure 5**. For additional vent location restrictions refer to **Figure 8 on page 6**.

TYPICAL INSTALLATION SEQUENCE

The typical sequence of installation follows, however, each installation is unique resulting in variations to those described.

See the page numbers references in the following steps for detailed procedures.

Step 1. (page 5) Construct the appliance framing. Position the appliance within the framing and secure with nailing brackets.

Step 2. (page 5) Route gas supply line to appliance location.

Horizontal Vent Termination Clearances

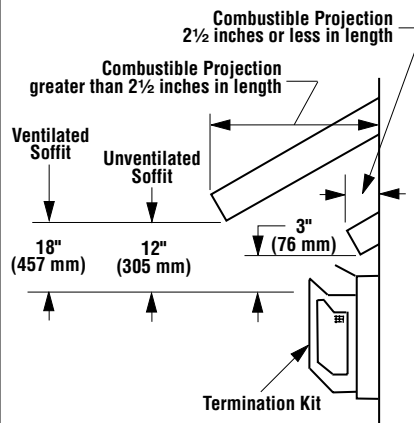

Note - See **Figure 34 on page 16** for the recess allowances, into exterior walls, of the round, square and small square horizontal terminations.

Figure 5 Side Elevation View

Step 3. (page 9) Install the vent system and exterior termination.

Step 4. (page 21) Field Wiring

a. Millivolt Appliances – Install the operating control switch (not factory provided) and bring in electrical service line for forced air circulating blower (optional equipment).

b. Electronic Appliances – Field wire and install operating control switch.

Step 5. (page 21) Install blower kit (optional equipment).

Step 6. (page 22) Make connection to gas supply.

Step 7. (page 22) Install the logs, decorative volcanic stone and glowing embers.

Step 8. (page 22) Checkout appliance operation.

Step 9. (page 23) Install glass door frame assembly.

Step 10. (page 23) Adjust burner to ensure proper flame appearance.

Step 11. (page 23) Install the hoods.

DETAILED INSTALLATION STEPS

The appliance is shipped with all gas controls and components installed and pre-wired. Remove the shipping carton, exposing the front glass door. Remove the top panel. **Remove the cardboard from underneath the pressure relief plates.** Gently depress the outer top corners of the access panel until the catches "pop" the panel free, allowing it to swing out and down to open. Open the two latches (located under the firebox floor) securing the glass door. Remove the door by tilting it outward at the bottom and lifting it up. Set the door aside protecting it from inadvertent damage. See **Figure 55 on page 23**.

Step 1. FRAMING

Frame these appliances as illustrated in **Figure 9 on page 7**, unless the appliance is to be installed in a corner.

See **Figure 10 on page 7** or **Figure 11 on page 8** for corner framing installations. All framing details must allow for a minimum clearance to combustible framing members as shown in **Table 2**.

If the appliance is to be elevated above floor level, a solid continuous platform must be constructed.

Headers may be in direct contact with the appliance top spacers but must not be supported by them or notched to fit around them. All construction above the appliance must be self supporting. **DO NOT** use the appliance for structural support.

The fireplace should be secured to the side framing members using the unit's nailing flanges - one top and bottom on each side of the fireplace front. See **Figure 6**. Use 8d nails or their equivalent.

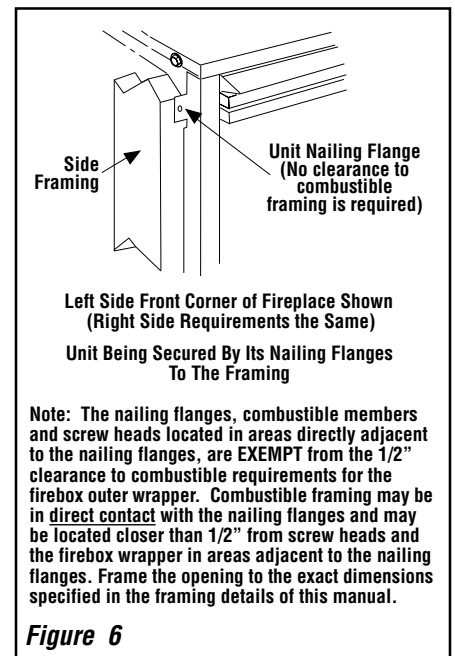

Figure 6

Step 2. ROUTING GAS LINE

Route a 1/2" (13 mm) gas line along the inside of the right side framing as shown in **Figure 7**. Gas lines must be routed, constructed and made of materials that are in strict accordance with local codes and regulations.

All appliances are factory-equipped with a flexible gas line connector and 1/2 inch shutoff valve. (See **step 6 on page 22**).

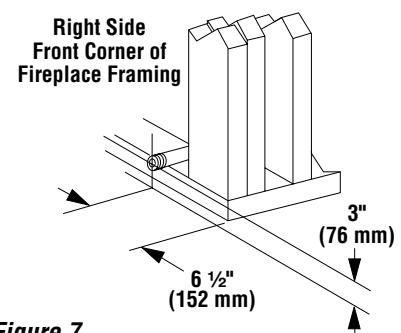
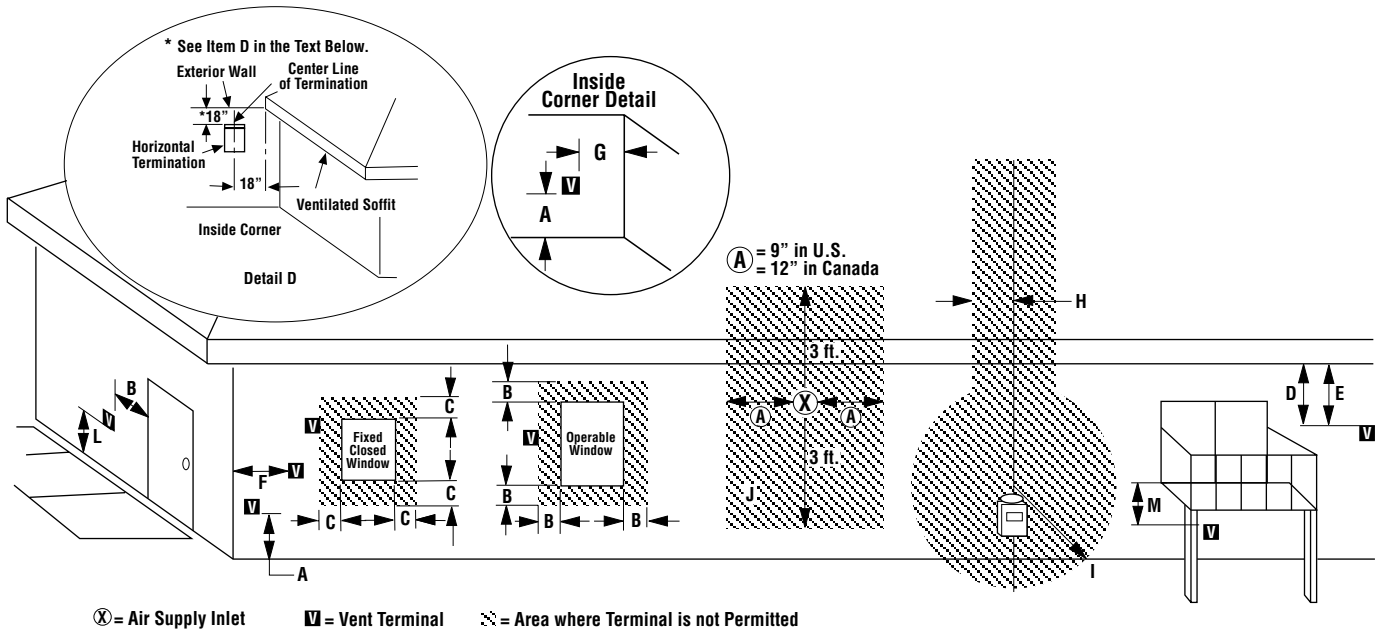

Figure 7

NOTE: DIAGRAMS & ILLUSTRATIONS NOT TO SCALE.

EXTERIOR HORIZONTAL VENT TERMINATION CLEARANCE REQUIREMENTS



	Canadian Installation*	US Installation**
A = Clearance above grade, veranda, porch, deck, or balcony.	12 inches (30cm)*	12 inches (30cm)**
B = Clearance to window or door that may be opened.	6 in (15cm) for appliances < 10,000 Btuh (3kW), 12 in (30cm) for appliances > 10,000 Btuh (3kW) and < 100,000 Btuh (30kW), 36 inches (91cm) for appliances > 100,000 Btuh (30kW)*	6 in (15cm) for appliances < 10,000 Btuh (3kW), 9 in (23cm) for appliances > 10,000 Btuh (3kW) and < 50,000 Btuh (15kW), 12 inches (30cm) for appliances > 50,000 Btuh (15kW)**
C = Clearance to permanently closed window	12" (305mm) recommended to prevent window condensation	9" (229mm) recommended to prevent window condensation
D = Vertical clearance to ventilated soffit located above the terminal within a horizontal distance of 18 inches (458mm) from the center line of the terminal	18" (458mm)	18" (458mm)
E = Clearance to unventilated soffit	12" (305mm)	12" (305mm)
F = Clearance to outside corner	5" (12.7cm) minimum	5" (12.7cm) minimum
G = Clearance to inside corner	6" (15.2cm) minimum	6" (15.2cm) minimum
H = Clearance to each inside of center line extended above meter/regulator assembly	3 feet (91cm) within a height of 15 feet above the meter/regulator assembly*	3 feet (91cm) within a height of 15 feet above the meter/regulator assembly**
I = Clearance to service regulator vent outlet	3 feet (91cm)*	3 feet (91cm)**
J = Clearance to nonmechanical air supply inlet to building or the combustion air inlet to any other appliance	6 in (15cm) for appliances < 10,000 Btuh (3kW), 12 in (30cm) for appliances > 10,000 Btuh (3kW) and < 100,000 Btuh (30kW), 36 inches (91cm) for appliances > 100,000 Btuh (30kW)*	6 in (15cm) for appliances < 10,000 Btuh (3kW), 9 in (23cm) for appliances > 10,000 Btuh (3kW) and < 50,000 Btuh (15kW), 12 inches (30cm) for appliances > 50,000 Btuh (15kW)**
K = Clearance to a mechanical air supply inlet	6 feet (1.83m)*	3 feet (91cm) above if within 10 feet (3m) horizontally**
L = Clearance above paved sidewalk or paved driveway located on public property	7 feet (2.13m)‡	7 feet (2.13m)‡
M = Clearance under veranda, porch, deck or balcony	12 inches (30cm)*‡	12 inches (30cm)‡

* In accordance with the current CSA-B149.1 National Gas And Propane Installation Code.

** In accordance with the current ANSI SZ223.1/NFPA 54 National Fuel Gas Codes.

‡ A vent shall not terminate directly above a sidewalk or paved driveway which is located between two single family dwellings and serves both dwellings.

*‡ Only permitted if veranda, porch, deck or balcony is fully open on a minimum 2 sides beneath the floor:

Figure 8

FIREPLACE FRAMING SPECIFICATIONS

****FRAMING WITH SQUARE HORIZONTAL TERMINATIONS (SV4.5HTSS or SV4.5HTS) AND ROUND HORIZONTAL TERMINATION (SV4.5HTR)**

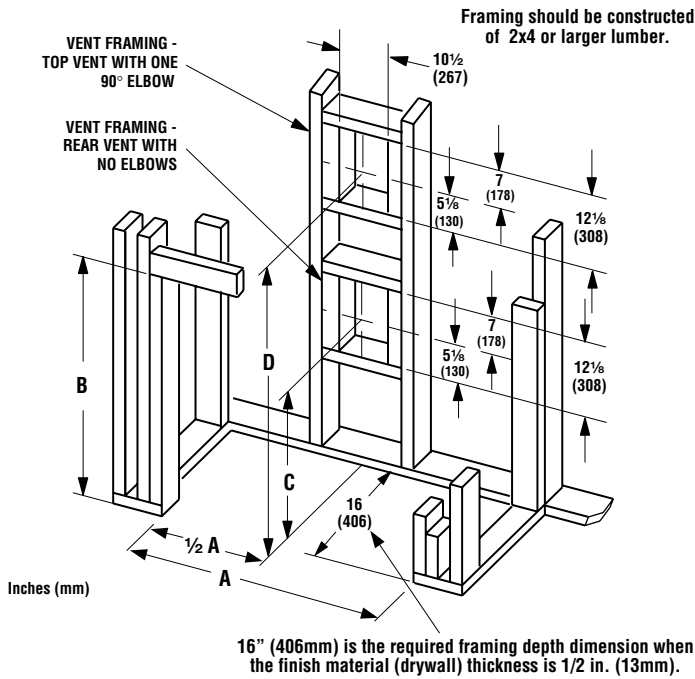

** See the horizontal venting Figures 33 and 34 on page 16 for restrictions on the use of the round termination (SV4.5HTR).

Figure 9

Framing Dimensions

Model No.		A	B	C	D
D-500	in.	35 1/4	35 1/4	21 11/16	39 1/8
	mm	895	895	551	994
DT-500	in.	35 1/4	35 1/4	----	39 1/8
	mm	895	895	----	994
DR-500	in.	35 1/4	35 1/4	21 11/16	----
	mm	895	895	551	----
D-600	in.	40 1/4	40 1/4	26 11/16	44 1/8
	mm	1022	1022	678	1121
DT-600	in.	40 1/4	40 1/4	----	44 1/8
	mm	1022	1022	----	1121
DR-600	in.	40 1/4	40 1/4	26 11/16	----
	mm	1022	1022	678	----
D-800	in.	45 1/4	40 1/4	26 11/16	44 1/8
	mm	1149	1022	678	1121
DT-800	in.	45 1/4	40 1/4	----	44 1/8
	mm	1149	1022	----	1121
DR-800	in.	45 1/4	40 1/4	26 11/16	----
	mm	1149	1022	678	----

Note-
Venting requirements for rear vent applications in corner installations -
- the round termination (SV4.5HTR) may not be used
- the horizontal vent length "a" to "b," must not exceed 28 inches (711 mm)

*These dimensions occur when one 45 degree elbow is connected directly to the appliance collar.

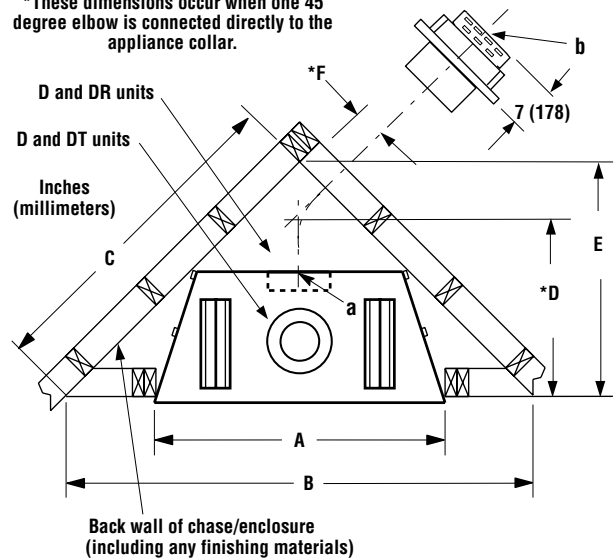

Model No.		A	B	C	D	E	F
D-500	in.	35 1/8	57 1/2	40 5/8	19 3/16	28 3/4	6 1/8
DT-500	mm	892	1461	1032	487	730	156
DR-500							
D-600	in.	40 1/8	61 3/16	43 1/32	19 3/16	30 11/16	7 7/8
DT-600	mm	1019	1554	1101	487	779	200
DR-600							
D-800	in.	45 1/8	66 3/8	46 15/16	19 3/16	33 3/16	9 3/4
DT-800	mm	1146	1686	1192	487	843	248
DR-800							

Figure 10 Corner Framing with Square Termination (SV4.5HTS)

FIREPLACE FRAMING SPECIFICATIONS

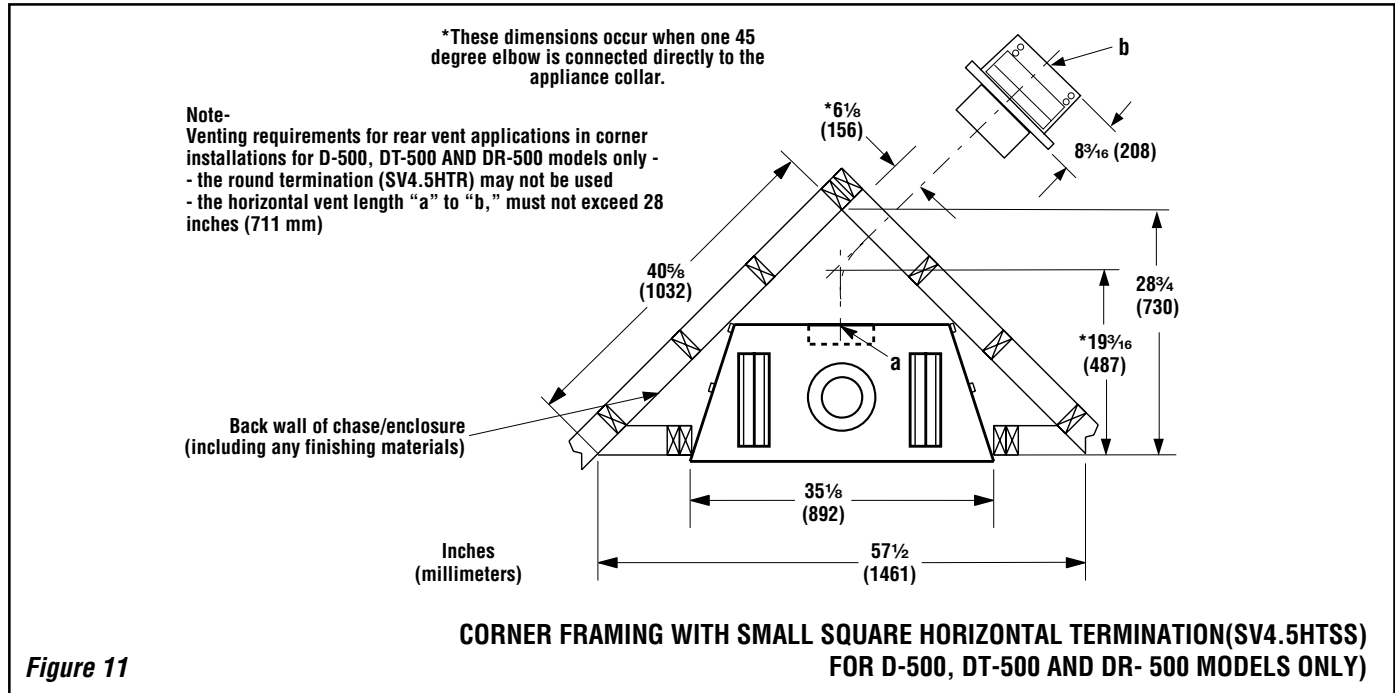

FIREPLACE SPECIFICATIONS

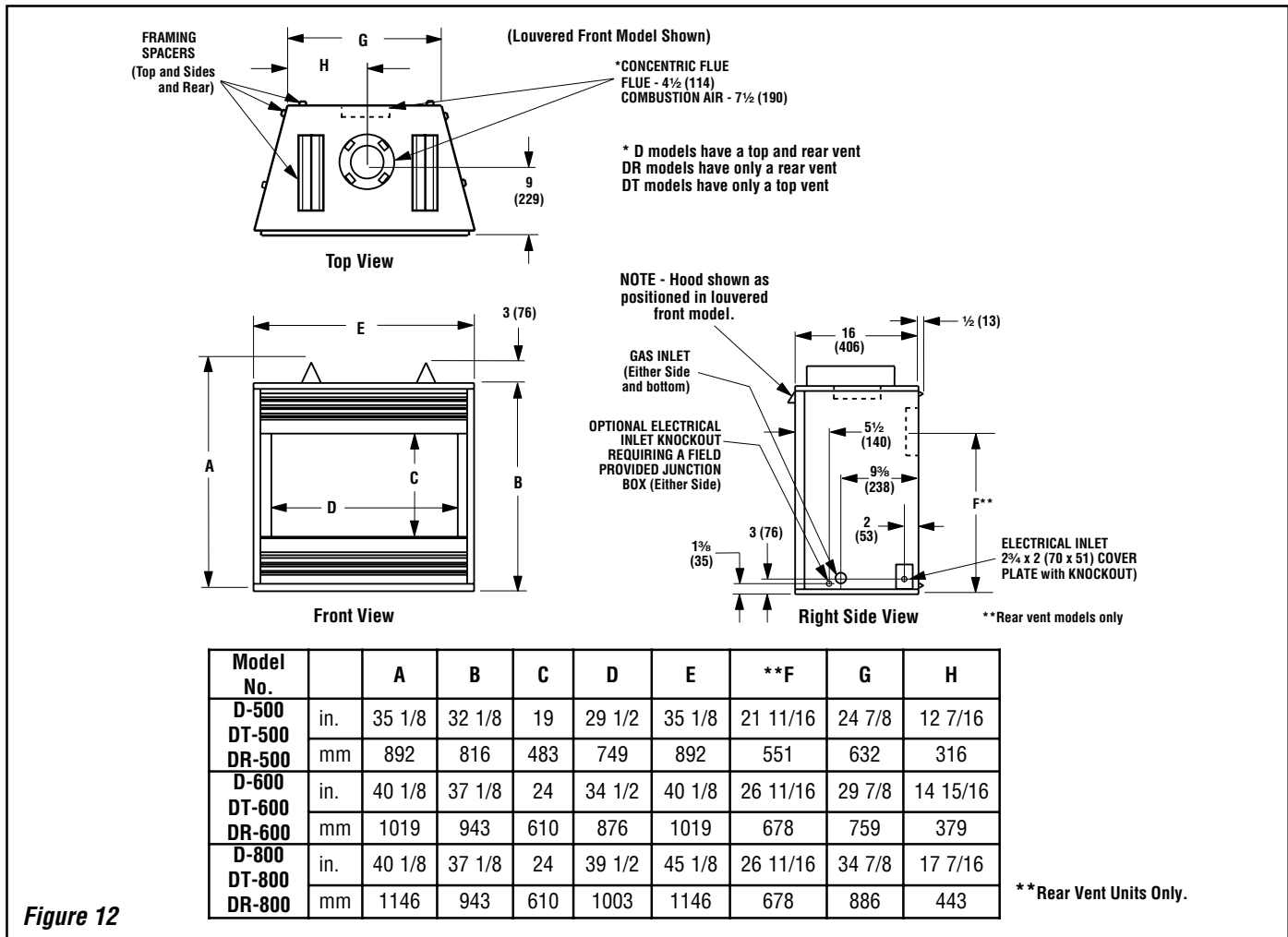

Step 3. INSTALL THE VENT SYSTEM

General Information

These instructions should be used as a guideline and do not supersede local codes in any way. Install vent according to local codes, these instructions, the current National Fuel Gas Code (ANSI-Z223.1) in the USA or the current standards of CAN/CGA-B149.1 and -B149.2 in Canada.

These fireplaces are designed, tested and listed for operation and installation with, and only with, Secure Vent™ (SV4.5) Direct Vent System Components, Secure Flex™ Flexible Vent Components manufactured by Security Chimneys International. These approved vent system components are labeled for identification. DO NOT use any other manufacturer's vent components with these appliances. These fireplaces must be vented directly to the outside.

The vent system may not service multiple appliances, and must never be connected to a flue serving a solid fuel burning appliance. The vent pipe is tested to be run inside an enclosing wall (such as a chase). There is no requirement for inspection openings in the enclosing wall at any of the joints in the vent pipe.

Preparing the Appliance Vent Collar on D-500/600/800 Series (Combined Top and Rear Vent) Models

Each of the unit's two vent collars are sealed with a cover plate and a seal plate and gasket. The cover, and seal plate and gasket must be removed from the vent collar being used. Refer to **Figure 13** for top vent usage and **Figure 14** for rear, and the following steps to prepare the appropriate collar for use.

From the vent collar being used, remove the four screws securing the vent seal plate and gasket. Remove and discard the seal plate and gasket.

When the top vent collar is being used, from inside the firebox, loosen the two screws in the keyhole slots of the cover plate and remove the remaining two cover plate securing screws. Remove and discard the cover plate. **Reinstall and securely tighten all four screws.**

When the rear vent collar is being used, from inside the firebox, remove the two screws securing the lintel to the rear wall of the firebox, then remove the lintel. Remove the four cover plate securing screws.

Remove and discard the cover plate. Reinstall and securely tighten all four cover plate screws. Re-secure the lintel to the rear wall of the firebox.

WARNING: FAILURE TO REINSTALL AND SECURELY TIGHTEN COVER PLATE SCREWS COULD RESULT IN LEAKAGE OF FLUE PRODUCTS INTO THE LIVING SPACE. VENT COVER PLATE AND VENT SEAL PLATE MUST REMAIN SECURELY INSTALLED ON UNUSED VENT COLLAR. FAILURE TO DO SO COULD RESULT IN LEAKAGE OF FLUE PRODUCTS INTO LIVING SPACE.

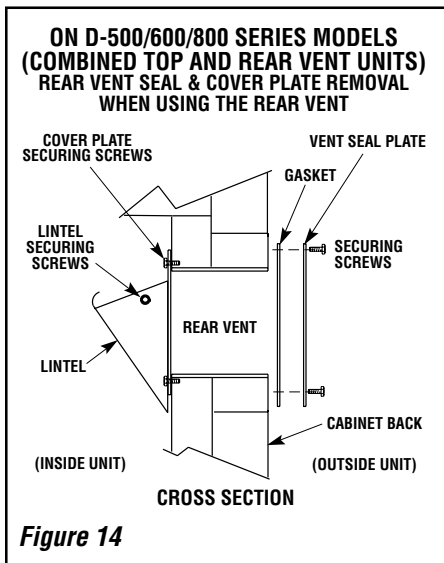
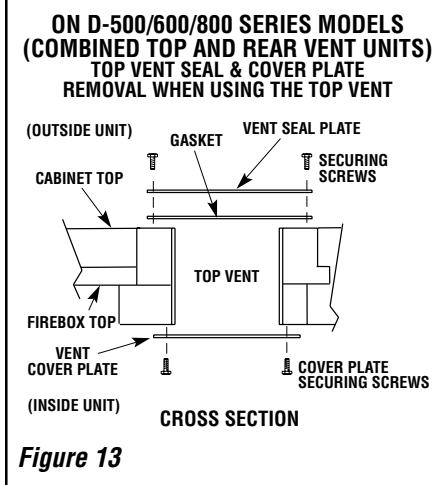

Installation of Vent Restrictor

A vent restrictor may be needed with this appliance, install the vent restrictor (provided) in the appliance top flue outlet as shown in **Figure 15** or rear flue outlet as shown in **Figure 16**. It is held in place by friction, only.

VENT RESTRICTOR INSTALLATION (TOP VENT)

A vent restrictor may be needed when vertically terminating the vent system above the roof (when using the appliance top vent), install vent restrictor in the top vent of the fireplace outlet on D-500/600/800 and DT-500/600/800 series models.

If needed, install the restrictor orientated as shown, either from inside or outside the unit, in the inner fireplace collar.

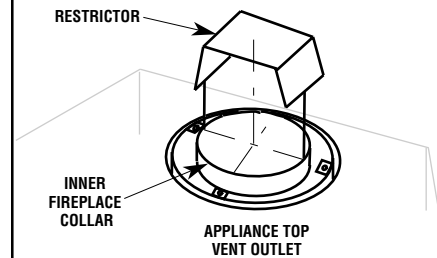

Figure 15

VENT RESTRICTOR INSTALLATION (REAR VENT)

A vent restrictor may be needed when horizontally terminating the vent system from the rear of the appliance (when using the appliance rear vent), install vent restrictor in the rear vent of the fireplace outlet on D-500/600/800 and DR-500/600/800 series models, in any installation that has a vertical vent run in excess of three feet (0.914 meters).

If needed, install the restrictor orientated as shown, either from inside or outside the unit, in the inner fireplace collar.

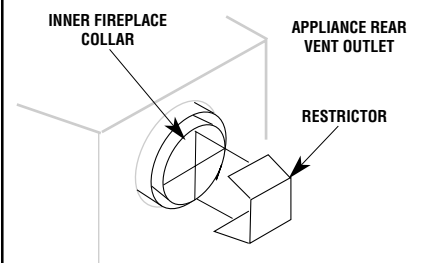

Figure 16

Select Venting System - Horizontal or Vertical

With the appliance secured in framing, determine vent routing and identify the exterior termination location. The following sections describe vertical (roof) and horizontal (exterior wall) vent applications. Refer to the section relating to your installation. **A list of approved venting components is shown in the two tables on page 24 and the two tables on page 25.**

VERTICAL TERMINATION SYSTEMS (ROOF)

Figure 17, and Figures 27 through 31 on pages 13 and 14 and their associated Vertical Vent Tables illustrate the various vertical venting configurations that are possible for use with these appliances. **Secure Vent** pipe applications are shown in these figures; **Secure Flex** pipe may also be used. A Vertical Vent Table summarizes each system's minimum and maximum vertical and horizontal length values that can be used to design and install the vent components in a variety of applications.

Both these vertical vent systems terminate through the roof. The minimum vent height above the roof and/or adjacent walls is specified in ANSI Z223.1-(latest edition) (In Canada, the current CAN-1 B149 installation code) by major building codes. Always consult your local codes for specific requirements. A general guide to follow is the Gas Vent Rule (refer to Figure 4 on page 5).

Vertical (Straight) Installation

Determine the number of straight vent sections required. 4 1/2" (114 mm), 10 1/2" (267 mm), 22 1/2" (572 mm), 34 1/2" (876 mm) and 46 1/2" (1181 mm) net section lengths are available. Plan the vent lengths so that a joint does not occur at the intersection of ceiling or roof joists. Refer to the Vent Section Length Chart.

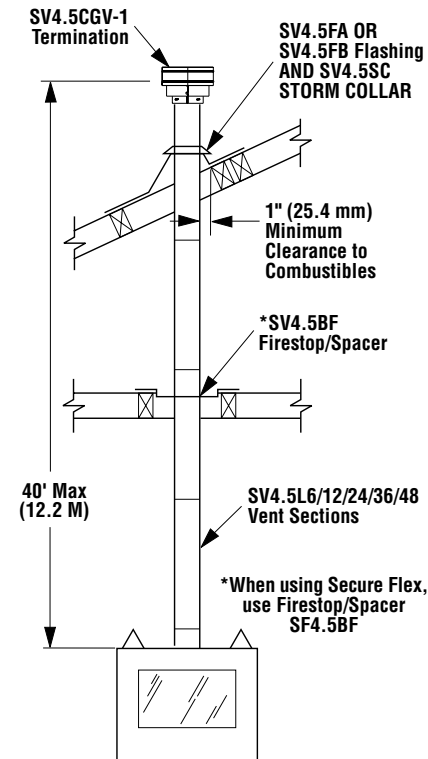

Figure 17

VENT SECTION LENGTH CHART							T O T A L Q U A N T I T Y
Nominal Section Length (inches)	6	12	24	36	48		
Net Section Length (inches)	4-1/2	10-1/2	22-1/2	34-1/2	46-1/2		
Height of Vent	Number of Vent Sections						
inches	ft						
4.5	0.375	1	0	0	0	0	1
9	0.75	2	0	0	0	0	2
10.5	0.875	0	1	0	0	0	1
15	1.25	1	1	0	0	0	2
19.5	1.625	2	1	0	0	0	3
21	1.75	0	2	0	0	0	2
22.5	1.875	0	0	1	0	0	1
25.5	2.125	1	2	0	0	0	3
31.5	2.625	0	3	0	0	0	3
34.5	2.875	0	0	0	1	0	1
37.5	3.125	1	1	1	0	0	3
43.5	3.625	0	2	1	0	0	3
45	3.75	0	0	2	0	0	2
46.5	3.875	0	0	0	0	1	1
49.5	4.125	1	0	2	0	0	3
51	4.25	1	0	0	0	1	2
55.5	4.625	0	1	2	0	0	3
57	4.75	0	0	1	1	0	2
66	5.25	0	2	2	0	0	4
67.5	5.625	0	0	3	0	0	3
69	5.75	0	0	0	2	0	2
72	6	1	0	3	0	0	4
73.5	6.125	1	0	0	2	0	3
79.5	6.625	0	1	0	2	0	3
81	6.75	0	0	0	1	1	2
90	7.5	0	2	1	0	1	4
91.5	7.625	0	0	2	0	1	3
93	7.75	0	0	0	0	2	2
96	8	1	0	1	2	0	4
97.5	8.125	1	0	0	0	2	3
102	8.5	2	0	0	0	2	4
103.5	8.625	0	0	0	3	0	3
108	9	1	0	0	3	0	4
114	9.5	0	2	0	0	2	4
117	9.75	1	0	5	0	0	6
118.5	9.875	1	1	0	3	0	5
126	10.5	0	0	1	3	0	4
130.5	10.875	1	0	1	3	0	5
135	11.25	0	0	6	0	0	6
138	11.5	0	0	0	4	0	4
139.5	11.625	0	0	0	0	3	3
142.5	11.875	1	0	0	4	0	5

VENT SECTION LENGTH CHART							T O T A L Q U A N T I T Y
Nominal Section Length (inches)	6	12	24	36	48		
Net Section Length (inches)	4-1/2	10-1/2	22-1/2	34-1/2	46-1/2		
Height of Vent	Number of Vent Sections						
inches	ft						
144	12	1	0	0	0	3	4
150	12.5	0	1	0	0	3	4
154.5	12.875	1	1	0	0	3	5
160.5	13.375	0	2	0	0	3	5
172.5	14.375	0	0	0	5	0	5
177	14.75	1	0	0	5	0	6
183	15.25	0	1	0	5	0	6
186	15.5	0	0	0	0	4	4
190.5	15.875	1	0	0	0	4	5
196.5	16.375	0	1	0	0	4	5
205.5	17.125	0	1	1	5	0	7
207	17.25	0	0	0	6	0	6
211.5	17.625	1	0	0	6	0	7
217.5	18.125	0	1	0	6	0	7
229.5	19.125	0	0	1	6	0	7
232.5	19.375	0	0	0	0	5	5
237	19.75	1	0	0	0	5	6
241.5	20.125	0	0	0	7	0	7
246	20.5	1	0	0	7	0	8
252	21	0	1	0	7	0	8
264	22	0	0	1	7	0	8
276	23	0	0	0	8	0	8
279	23.25	0	0	0	0	6	6
280.5	23.375	1	0	0	8	0	9
283.5	23.625	1	0	0	0	6	7
289.5	24.125	0	1	0	0	6	7
301.5	25.125	0	0	1	0	6	7
310.5	25.875	0	0	0	9	0	9
315	26.5	1	0	0	9	0	10
325.5	27.125	0	0	0	0	7	7
330	27.5	1	0	0	0	7	8
336	28	0	1	0	0	7	8
345	28.75	0	0	0	10	0	10
349.5	29.125	1	0	0	10	0	11
372	31	0	0	0	0	8	8
376.5	31.375	1	0	0	0	8	9
379.5	31.625	0	0	0	11	0	11
418.5	34.875	0	0	0	0	9	9
423	35.25	1	0	0	0	9	10
465	38.75	0	0	0	0	10	10

NOTE: DIAGRAMS & ILLUSTRATIONS NOT TO SCALE.

Vertical (Offset) Installation

Analyze the vent routing and determine the quantities of vent sections and number of elbows required. Refer to **Vertical Vent Figures and Tables on page 13 and 14** to select the type of vertical installation desired. Vent sections are available in net lengths of 4 1/2" (114 mm), 10 1/2" (267 mm), 22 1/2" (572 mm), 34 1/2" (876 mm) and 46 1/2" (1181 mm). Refer to the **Vent Section Length Chart on page 10** for an aid in selecting length combinations. Elbows are available in 90° and 45° configurations. Refer to **Figure 22** for the SV4.5E45 and SV4.5E90 elbow dimensional specifications.

Where required, a **telescopic vent section (SV4.5LA)** may be used to provide the installer with an option in installing in tight and confined spaces or where the vent run made up of fixed length pieces develops a joint in a undesirable location, or will not build up to the required length. The SV4.5LA Telescopic Vent Section has an effective length of from 1 1/2" (38 mm) to 7 1/2" (191 mm). The SV4.5LA is fitted with a locking inclined channel end (identical to a normal vent section component) and a plain end with 3 pilot holes. Slip the plain end over the locking channel end of a standard SV4.5 vent component the required distance and secure with three screws.

Maintain a minimum 1" (25 mm) clearance to combustible materials for all vertical elements. Clearances for all horizontal elements are 3" (76 mm) on top, 1" (25 mm) on sides and 1" (25 mm) on the bottom.

A. Frame ceiling opening - Use a plumb line from the ceiling above the appliance to locate center of the vertical run. Cut and/or frame an opening, 10 1/2" x 10 1/2" (267mm x 267mm) inside dimensions, about this center mark (**Figure 18**).

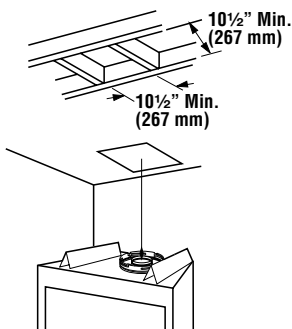

Figure 18

B. Attach vent components to appliance - Secure Vent SV4.5 direct vent system components are unitized concentric pipe components featuring positive twist lock connections (see **Figure 19**).

All of the appliances covered in this document are fitted with collars having locking inclined channels. The dimpled end of the vent components fit over the appliance collar to create the positive twist lock connection.

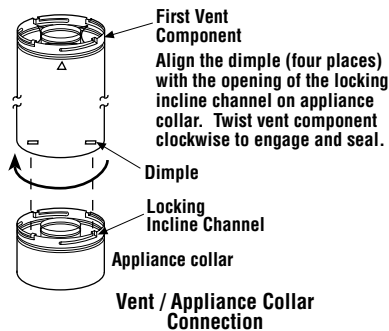

Figure 19

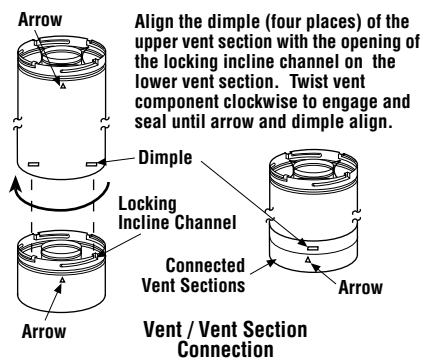

Figure 20

To attach a vent component to the appliance collar, align the dimpled end over the collar, adjusting the radial alignment until the four locking dimples are aligned with the inlet of the four inclined channels on the collar (*refer to Figure 19*). Push the vent component against the collar until it fully engages, then twist the component clockwise, running the dimples down and along the incline channels until they seat at the end of the channels.

The unitized design of the **Secure Vent** components will engage and seal both the inner and outer pipe without the need for sealant or screws. If desired, a #6 x 1/2" screw may be used at the joint, but is not required as the pipe will securely lock when twisted.

Note: An elbow may also be attached to the appliance collar. Attach in the same manner as you would a vent section.

C. Attach vent components to each other - Other vent sections may be added to the previously installed section in accordance with the requirements of the vertical vent figures and tables.

To add another vent component to a length of vent run, align the dimpled end over the inclined channel end of the previously installed section, adjusting the radial alignment until the four locking dimples are aligned with the inlets of the four incline channels of the previous section.

Push the vent component against the previous section until it fully engages, then twist the component clockwise running the dimples down and along the incline channels until they seat at the end of the channels. **This seating position is indicated by the alignment of the arrow and dimple as shown in Figure 20.**

D. Install firestop/spacer at ceiling - When using Secure Vent, use SV4.5BF firestop/spacer at ceiling joists; when using Secure Flex, use SF4.5BF firestop/spacer. If there is living space above the ceiling level, the firestop/spacer must be installed on the bottom side of the ceiling. If attic space is above the ceiling, the firestop/spacer must be installed on the top side of the joist. Route the vent sections through the framed opening and secure the firestop/spacer with 8d nails or other appropriate fasteners at each corner.

Remember to maintain 1" (25 mm) clearance to combustibles, framing members, and attic or ceiling insulation when running vertical chimney sections.

E. Support the vertical vent run sections - Support the vertical portion of the venting system every 8 feet (2.4m) above the fireplace vent outlet using field provided support straps (conventional plumber's tape). Secure the plumber's tape to the framing members with nails or screws.

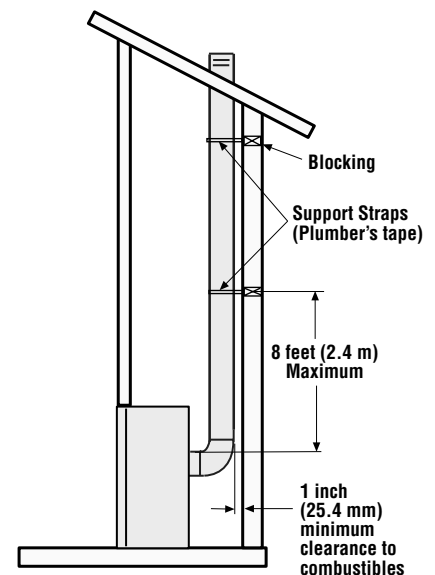

Figure 21

Loop the tape around the vent, securing the ends of the tape to the framing. If desired, sheet metal screws #6 x 1/2" length may be used to secure the support straps to the vent pipe. Refer to **Figure 21**.

F. Change vent direction to horizontal/inclined run - At transition from or to a horizontal/inclined run, install the SV4.5E45 and SV4.5E90 elbows in the same manner as the straight vent sections. The elbows feature a twist section to allow them to be routed about the center axis of their initial collar section to align with the required direction of the next vent run element. **Twist elbow sections in a clockwise direction only so as to avoid the possibility of unlocking any of the previously connected vent sections.** See **Figure 22**.

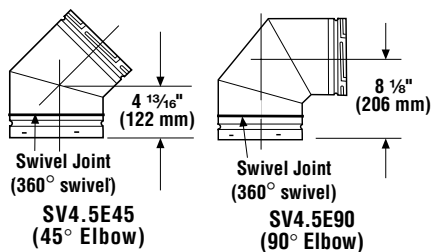
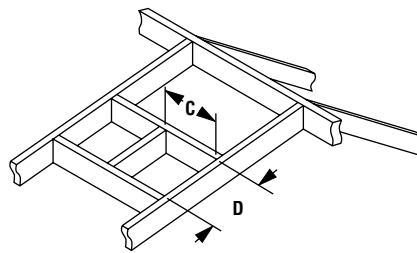

Figure 22

G. Continue installation of horizontal/inclined sections - Continue with the installation of the straight vent sections in horizontal/inclined run as described in **Step C**. Install support straps every 5' (1.52 m) along horizontal/inclined vent runs using conventional plumber's tape. **It is very important that the horizontal/inclined run be maintained in a straight (no dips) and recommended to be in a slightly elevated plane, in a direction away from the fireplace of 1/4" rise per foot (20 mm per meter) which is ideal, though rise per foot run ratios that are smaller are acceptable all the way down to at or near level.** Use a carpenter's level to measure from a constant surface and adjust the support straps as necessary.

It is important to maintain the required clearances to combustibles: 1" (25 mm) at all sides for all vertical runs; and 3" (76 mm) at the top, 1" (25 mm) at sides, and 1" (25 mm) at the bottom for all horizontal/inclined runs.

H. Frame roof opening - Identify location for vent at the roof. Cut and/or frame opening per Roof Framing Chart and **Figure 23**.



Framing Dimensions for Roof

Pitch	C	D
0/12	10½ in. (267 mm)	10½ in. (267 mm)
6/12	10½ in. (267 mm)	12 in. (305 mm)
12/12	10½ in. (267 mm)	17 ¾ in. (451 mm)

Figure 23

I. Install the roof flashing - Extend the vent sections through the roof structure. Install the roof flashing over the vent section and position such that the vent column rises vertically (use carpenter's level) (**Figure 24**). Nail along perimeter to secure flashing or adjust roofing to overlap the flashing edges at top and sides only and trim where necessary. Seal the top and both sides of the flashing with waterproof caulking.

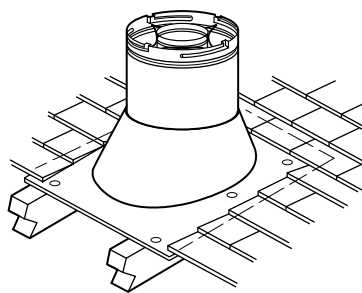

Figure 24

J. Install the storm collar - Install the storm collar, supplied with the flashing, over the vent/flashing joint. See **Figure 25**. Loosen the storm collar screw. Slide collar down until it meets the top of the flashing. Tighten the adjusting screw. Apply non-combustible caulking or mastic around the circumference of the joint to provide a water tight seal.

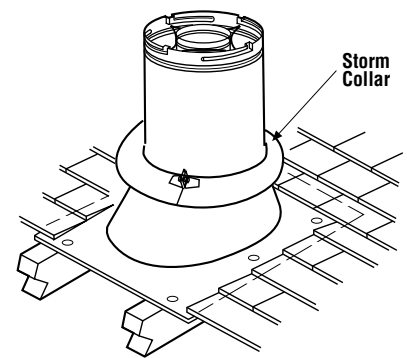

Figure 25

K. Install the vertical termination - The final step involves installation of the SV4.5CGV-1 Vertical Termination. Extend the vent sections to the height as shown in the "Vertical vent termination section" on **page 5**. The SV4.5CGV-1 Vertical Termination (**Figure 26**) installs in the exact same fashion as any other **Secure Vent** section. Align the termination over the end of the previously installed section, adjusting the radial alignment until the four locking dimples of the termination are aligned with the inlets of the four incline channels of the last vent section. Push the termination down until it fully engages, then twist the termination clockwise running the dimples down and along the incline channels until they seat at the end of the channels.

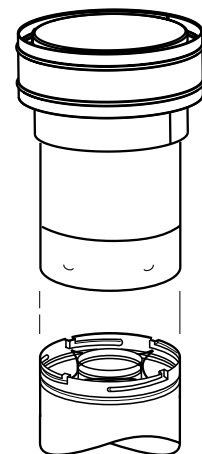

Figure 26

If the vent system extends more than 5' (1.5 m) above the roof flashing, stabilizers may be necessary. Additional screws may be used at section joints for added stability. Guide wires may be attached to the joint for additional support on multiple joint configurations.

VERTICAL VENT FIGURES/TABLES

Note: *Secure Vent* (rigid vent pipe) is shown in the figures; *Secure Flex* (flexible vent pipe) may also be used.

WARNING: UNDER NO CIRCUMSTANCES MAY SEPARATE SECTIONS OF CONCENTRIC FLEXIBLE VENT PIPE BE JOINED TOGETHER.

Note: It is very important that the horizontal/inclined run be maintained in a straight (no dips) and recommended to be in a slightly elevated plane, in a direction away from the fireplace of 1/4" rise per foot (20 mm per meter) which is ideal, though rise per foot run ratios that are smaller are acceptable all the way down to at or near level.

Note: SV4.5BF (Secure Vent), SF4.5BF (Secure Flex) firestop/spacer must be used anytime vent pipe passes through a combustible floor or ceiling. SV4.5HF (Secure Vent), SF4.5HF (Secure Flex) firestop/spacer must be used anytime vent pipe passes through a combustible wall.

Note: Two 45 degree elbows may be used in place of one 90 degree elbow. The same rise to run ratios, as shown in the venting figures for 90 elbows, must be followed if 45 degree elbows are used.

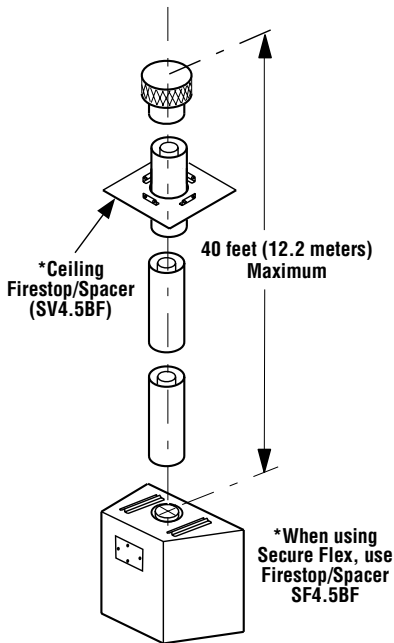

Figure 27 - Top Vent - STRAIGHT

TABLE A

V MINIMUM		H Maximum	
feet	(m)	feet	(m)
1	(0.305)	2	(0.61)
2	(0.61)	4	(1.22)
3	(0.914)	6	(1.86)
4	(1.22)	8	(2.4)

V + H = 40 feet (12.4 m) Max.
H = 8 feet (2.4 m) Max.

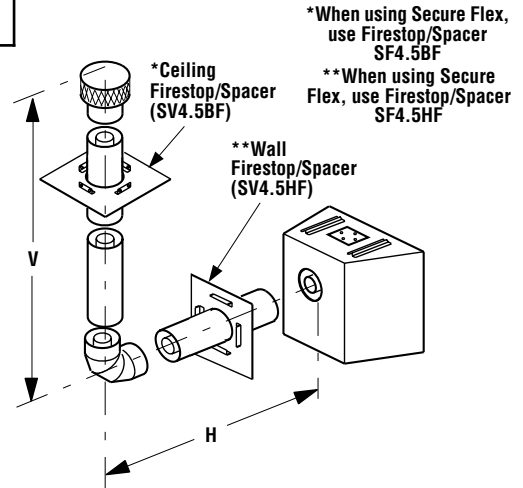

Figure 28 - Rear Vent - ONE 90 DEGREE ELBOW

TABLE B

V MINIMUM		H Maximum	
feet	(meters)	feet	(meters)
1	(0.305)	5	(1.52)
2	(0.610)	10	(3.1)
3	(0.914)	15	(4.65)
4	(1.22)	20	(6.2)

V + V₁ + H = 40 feet (12.4 m) Max.
H = 20 feet (6.2 m) Max.

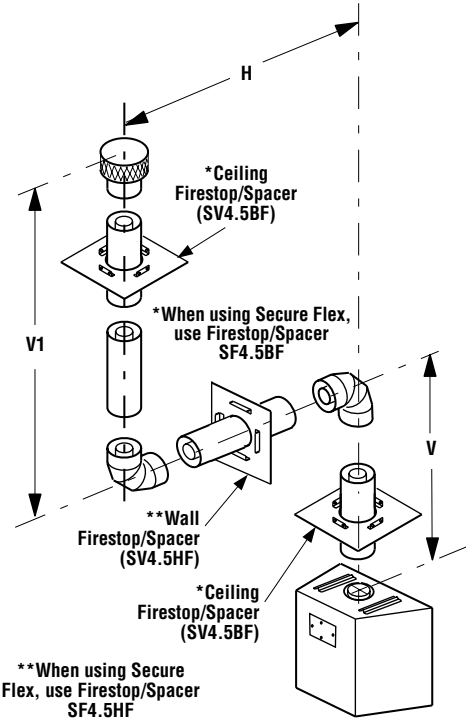

Figure 29 - Top Vent - TWO 90 DEGREE ELBOWS

VERTICAL VENT FIGURES/TABLES
(continued)

TABLE D					
V Minimum		H Maximum		H+H ₁ Maximum	
feet	(m)	feet	(m)	feet	(m)
1	(0.305)	2	(0.610)	5	(1.52)
2	(0.610)	4	(1.22)	10	(3.1)
3	(0.914)	6	(1.86)	15	(4.65)
4	(1.22)	8	(2.48)	20	(6.2)
V+V ₁ +H+H ₁ = 40 feet (12.4 m) Max. H = 8 feet (2.48 m) Max. H + H ₁ = 20 feet (6.2 m) Max.					

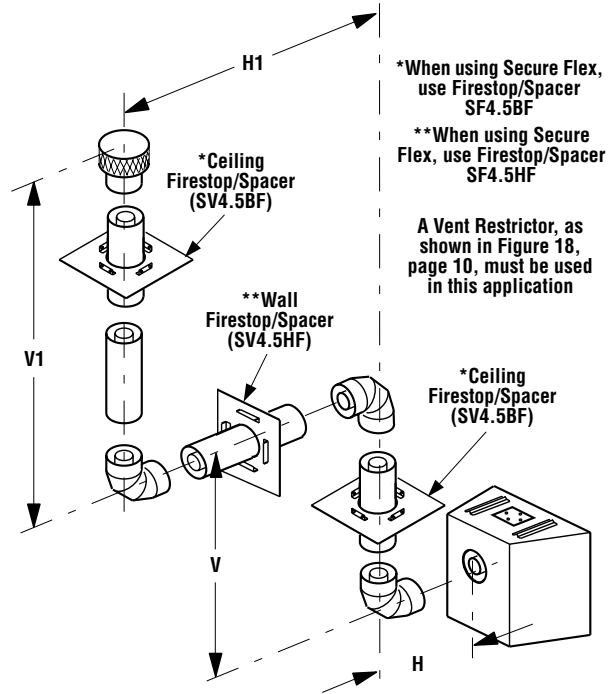

Figure 30 - Rear Vent - THREE ELBOWS

TABLE E			
V MINIMUM		H + H ₁ Maximum	
feet	(m)	feet	(m)
1	(0.305)	5	(1.52)
2	(0.610)	10	(3.1)
3	(0.914)	15	(4.65)
4	(1.22)	20	(6.2)
H + H ₁ = 20 feet (6.2 m) Max. V+V ₁ +H+H ₁ = 40 feet (12.4 m) Max.			

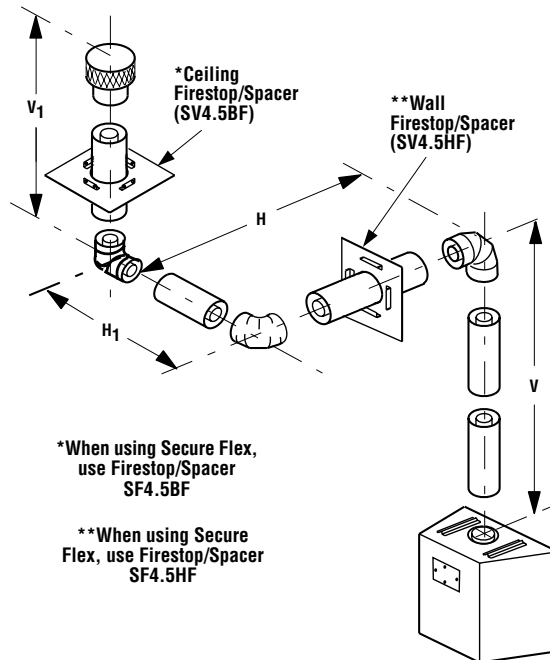

Figure 31 - Top Vent - THREE ELBOWS

HORIZONTAL (OUTSIDE WALL) TERMINATION SYSTEM

Figure 32, and Figures 36 to 43 on pages 17, 18 and 19 and their associated Horizontal Vent Table illustrate the various horizontal venting configurations that are possible for use with these appliances. **Secure Vent** pipe applications are shown in these figures; **Secure Flex** pipe may also be used. A Horizontal Vent Table summarizes each system's minimum and maximum vertical and horizontal length values that can be used to design and install the vent components in a variety of applications.

Both of these horizontal vent systems terminate through an outside wall. Building Codes limit or prohibit terminating in specific areas. Refer to **Figure 8 on page 6** for location guidelines.

Secure Vent SV4.5 direct vent system components are unitized concentric pipe components featuring positive twist lock connection, (refer to **Figure 19 on page 11**). All of the appliances covered in this document are fitted with collars having locking inclined channels. The dimpled end of the vent components fit over the appliance collar to create the positive twist lock connection.

A. Plan the vent run -

Analyze the vent routing and determine the types and quantities of sections required 4 1/2" (114 mm), 10 1/2" (267 mm), 22 1/2" (572 mm), 34 1/2" (876 mm) and 46 1/2" (1181 mm) net section lengths are available. Make allowances for elbows as indicated in **Figure 19**.

Maintain a minimum 1" (25 mm) clearance to combustibles on the vertical sections. Clearances for the horizontal runs are; 3" (76 mm) on top, 1" (25 mm) on sides, and 1" (25 mm) at the bottom.

B. Frame exterior wall opening -

Locate the center of the vent outlet on the exterior wall according to the dimensions shown in **Figure 9 on page 7**. Cut and/or frame an opening, 10 1/2" x 12 5/8" (267 mm x 308mm) inside dimensions, about this center.

C. Frame ceiling opening -

If the vertical route is to penetrate a ceiling, use plumb line to locate the center above the appliance. Cut and/or frame an opening, 10 1/2" x 10 1/2" (267 mm x 267 mm) inside dimensions, about this center (refer to **Figure 18 on page 11**).

D. Attach vent components to appliance -

To attach a vent component to the appliance collar, align the dimpled end over the collar, adjusting the radial alignment until the four locking dimples are aligned with the inlets of the four incline channels on the collar (refer to **Figure 19 on page 11**).

Push the vent component against the collar until it fully engages, then twist the component clockwise, running the dimples down and along the incline channels until they seat at the end of the channels.

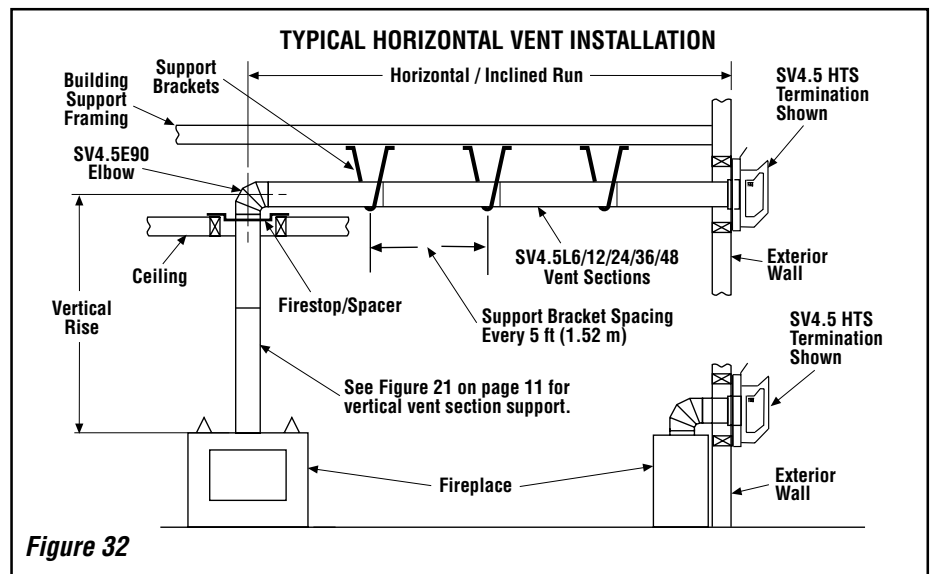

Figure 32

The unitized design of the **Secure Vent** components will engage and seal both the inner and outer pipe elements with the same procedure. Sealant and securing screws are not required.

Note: An elbow may also be attached to the appliance collar. Attach in the same manner as you would a vent section.

E. Attach vent components to each other -

Other vent sections may be added to the previously installed section in accordance with the requirements of the vent tables. To add another vent component to a length of vent run, align the dimpled end of the component over the inclined channel end of the previously installed section, adjusting the radial alignment until the four locking dimples are aligned with the inlets of the four incline channels of the previous section. Push the vent component against the previous section until it fully engages, then twist the component clockwise running the dimples down and along the incline channels until they seat at the end of the channels. **This seating position is indicated by the alignment of the arrow and dimple as shown in Figure 20 on page 11.**

F. Install firestop/spacer at ceiling -

When using **Secure Vent**, use SV4.5BF firestop/spacer at ceiling joists; when using **Secure Flex**, use SF4.5BF firestop/spacer. If there is living space above the ceiling level, the firestop/spacer must be installed on the bottom side of the ceiling. If attic space is above the ceiling, the firestop/spacer must be installed on the top side of the joist. Route the vent sections through the framed opening and secure the firestop/spacer with 8d nails or other appropriate fasteners at each corner.

Remember to maintain 1" (25 mm) clearance to combustibles, framing members, and attic or ceiling insulation when running vertical chimney sections.

G. Support the vertical run sections - See Section E on page 11.

H. Change vent direction - At transition from or to a horizontal/inclined run, install the SV4.5E45 and SV4.5E90 elbows in the same manner as the straight vent sections. The elbows feature a twist section to allow them to be routed about the center axis of their initial collar section to align with the required direction of the next vent run element. **Twist elbow sections in a clockwise direction only so as to avoid the possibility of unlocking any of the previously connected vent sections.** See **Figure 22**.

I. Continue installation of horizontal/inclined sections -

Continue with the installation of the straight vent sections in horizontal/inclined run as described in **Step E**. Install support straps every 5 ft. (1.52 m) along horizontal/inclined vent runs using conventional plumber's tape. See **Figure 32**. **It is very important that the horizontal/inclined run be maintained in a straight (no dips) and recommended to be in a slightly elevated plane, in a direction away from the fireplace of 1/4" rise per foot (20 mm per meter) which is ideal, though rise per foot run ratios that are smaller are acceptable all the way down to at or near level.**

It is important to maintain the required clearances to combustibles: 1" (25 mm) at all sides for all vertical runs; and 3" (76 mm) at the top, 1" (25 mm) at sides, and 1" (25 mm) at the bottom for all horizontal/inclined runs

J. Assemble vent run to exterior wall - If not previously measured, locate the center of the vent at the exterior wall. Prepare an opening as described in **Step B**. Assemble the vent system to point where the terminus of the last section is within 5 in. (127 mm) to 9 1/4 in. (235 mm) inboard of the exterior surface to which the termination is to be attached, see **Figure 34**.

If the terminus of the last section is not within this distance, use the **telescopic vent section SV4.5LA**, as the last vent section. For wall thicknesses greater than that shown in **Figure 34**, refer to **table 3 on page 17**. This table lists the additional venting components needed (in addition to the termination and adapter) for a particular range of wall thicknesses.

K. Attach termination adapter - Attach the adapter (adapter - SV4.5RCH - provided with the termination) to the vent section or telescoping vent section, elbow or appliance collar as shown in **Figure 33** in the same manner as any SV4.5 vent component (refer to **Step E**).

L. Install Firestop/Spacer at exterior wall - When using the **square** termination, install SV4.5HF (Secure Vent), SF4.5HF (Secure Flex) Firestop/Spacer over the opening at the exterior side of the framing, long side up, with the 3 inch spacer clearance at the top as shown in **Figure 34**, and nail into place. (The Firestop/Spacer may also be installed over the opening at the interior side of the framing.) When using the **round** termination, a separate firestop/spacer is not required since this termination has integral spacers which provide the same function as a separate firestop/spacer.

M. Install the desired termination - **See the horizontal venting figures for application restrictions on the round termination (SV4.5HTR) and the small square horizontal termination (SV4.5HTSS).**

1. Install the square termination (SV4.5HTS) or (SV4.5HTSS) - For the last step, from outside the exterior wall, slide the collars of the termination onto the adapter (the outer over the outer and the inner inside the inner) until the termination seats against the exterior wall surface to which it will be attached. Orient the housing of the termination with the arrow pointed upwards. Secure the termination to the exterior wall. **The horizontal termination must not be recessed into the exterior wall or siding** by more than the 1 ¼" (32 mm) as shown in **Figure 34**.

2. Install the round termination (SV4.5HTR) - See **Figure 35** for an illustration of the round termination. For the last step, from outside the exterior wall, slide the collars of the termination onto the adapter (the outer over the outer and the inner inside the inner) until the termination seats against the exterior wall surface to which it will be attached. Orient the housing of the termination with the arrow pointed upwards. Secure the termination to the exterior wall.

SFHRK Snorkel Cap -The snorkel cap is designed to be fitted into a basement window box. The SFHRK cap is for use with flex vent pipe. The vertical distance between the inlet and outlet of the cap is 28 in. (711 mm).

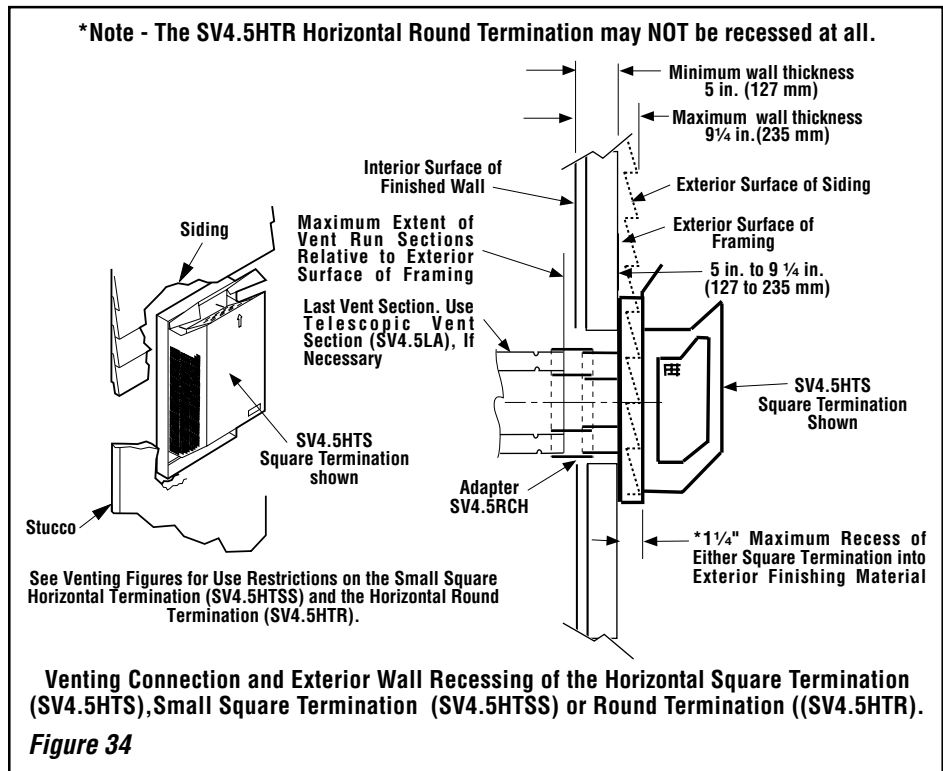
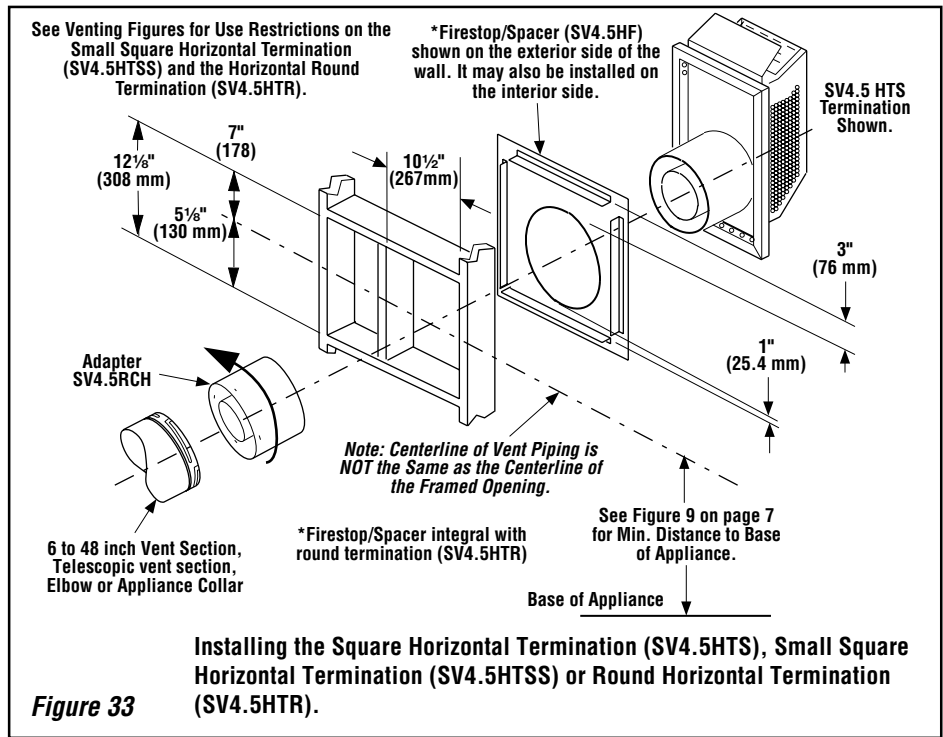

The SV4.5HTR Round Termination may not be used when the appliance is vented directly out the wall from the rear (as shown in Figures 36 or 37 on page 17). Do Not recess the SV4.5HTR round termination at all.

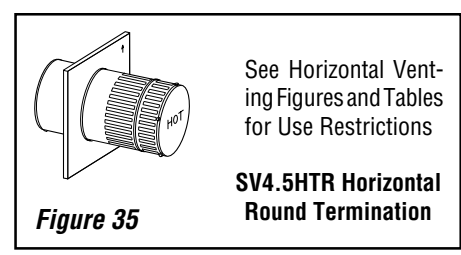

HORIZONTAL VENT FIGURES/TABLES

Note: *Secure Vent* components (rigid vent pipe and terminal) are shown in the figures; *Secure Flex* components (flexible vent pipe and terminal) may also be used.

Note: Two 45 degree elbows may be used in place of one 90 degree elbow. The same rise to run ratios, as shown in the venting figures for 90 elbows, must be followed if 45 degree elbows are used.

Note: *SV4.5BF* (*Secure Vent*), *SF4.5BF* (*Secure Flex*) firestop/spacer must be used anytime vent pipe passes through a combustible floor or ceiling. *SV4.5HF* (*Secure Vent*), *SF4.5HF* (*Secure Flex*) firestop/spacer must be used anytime vent pipe passes through a combustible wall.

WARNING: UNDER NO CIRCUMSTANCES MAY SEPARATE SECTIONS OF CONCENTRIC FLEXIBLE VENT PIPE BE JOINED TOGETHER.

Note: It is very important that the horizontal/inclined run be maintained in a straight (no dips) and recommended to be in a slightly elevated plane, in a direction away from the fireplace of 1/4" rise per foot (20 mm per meter) which is ideal, though rise per foot run ratios that are smaller are acceptable all the way down to at or near level.

Venting Components Required	Exterior Wall Thickness inches (mm)
Termination Kit Only	5 to 9 1/4 (127 to 235)
Termination Kit and 6 in. vent section (SV4.5L6)	9 1/4 to 13 3/4 (235 to 349)
Termination Kit and 12 in. vent section (SV4.5L12)	15 3/4 to 19 3/4 (400 to 502)
Termination Kit and Telescopic section (SV4.5LA) and 6 in. vent section (SV4.5L6)	10 3/4 to 20 3/4 (273 to 527)

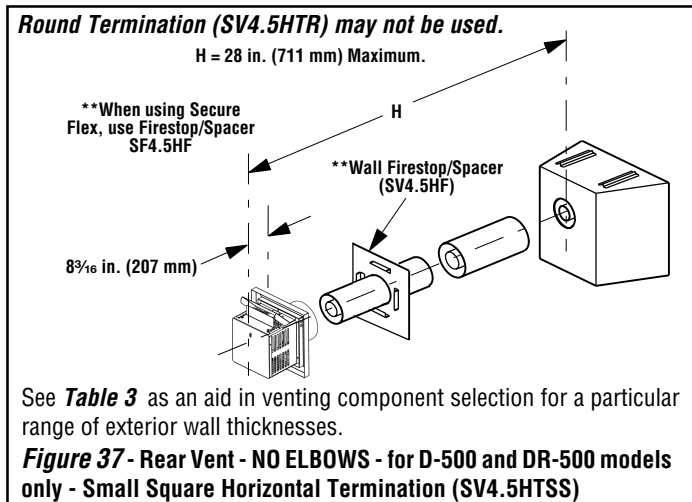
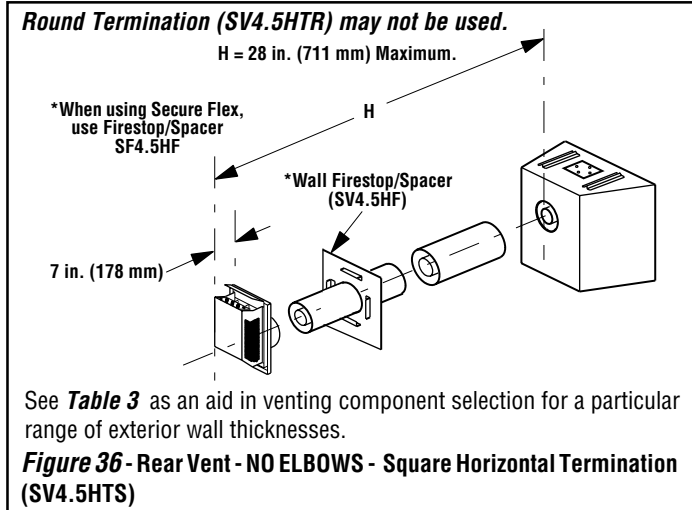

Square termination (SV4.5HTS) shown; Round Termination (SV4.5HTR) may also be used. Small Square termination (SV4.5HTSS) may only be used on DT-500 and D-500 models.

V = One 90 degree elbow
H = 3 feet (0.914 m) Max.

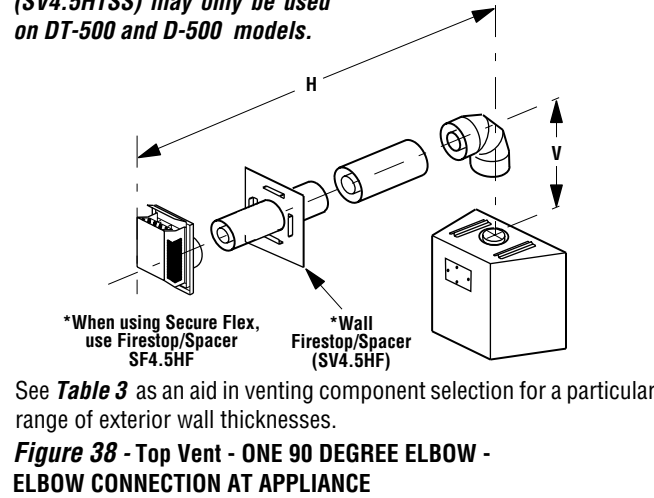

V Minimum		H Maximum	
feet	(m)	feet	(m)
1	(0.305)	5	(1.52)
2	(0.61)	10	(3.1)
3	(0.914)	15	(4.65)
4	(1.22)	20	(6.2)

V + H = 40 feet (12.4 m) Max.
H = 20 feet (6.2 m) Max.

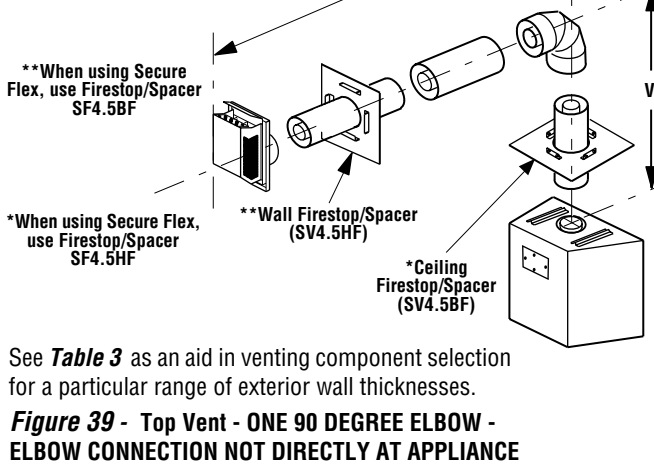

HORIZONTAL VENT FIGURES/TABLES
(continued)

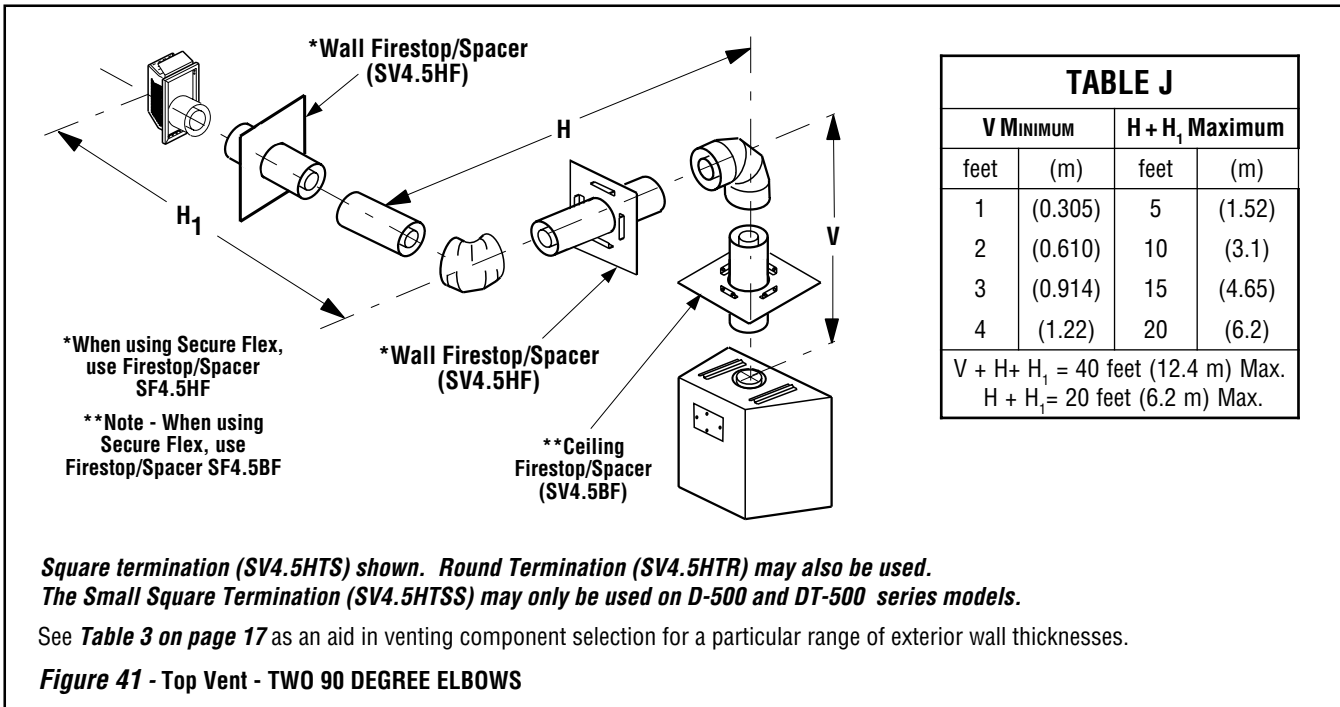
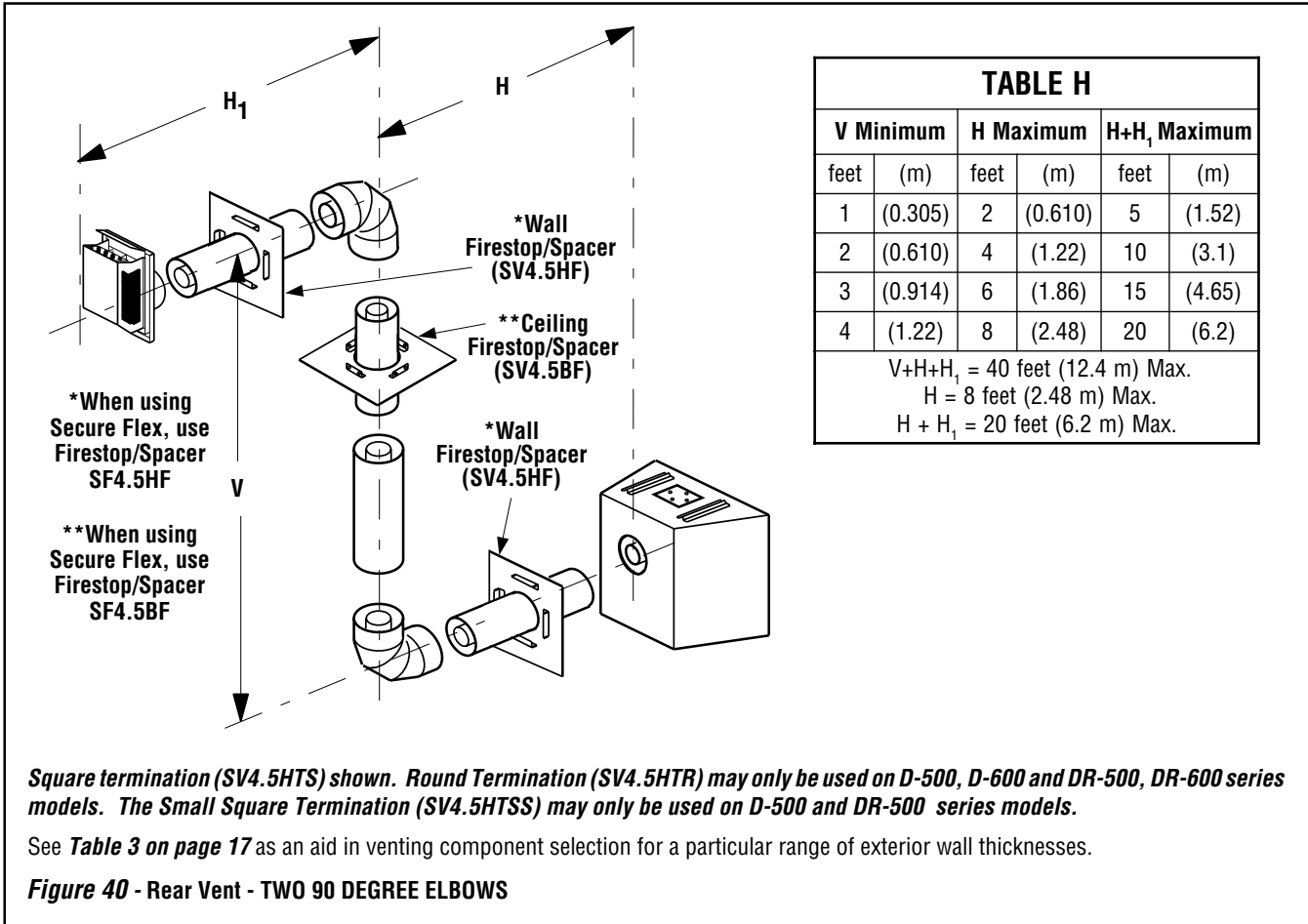

HORIZONTAL VENT FIGURES/TABLES
(continued)

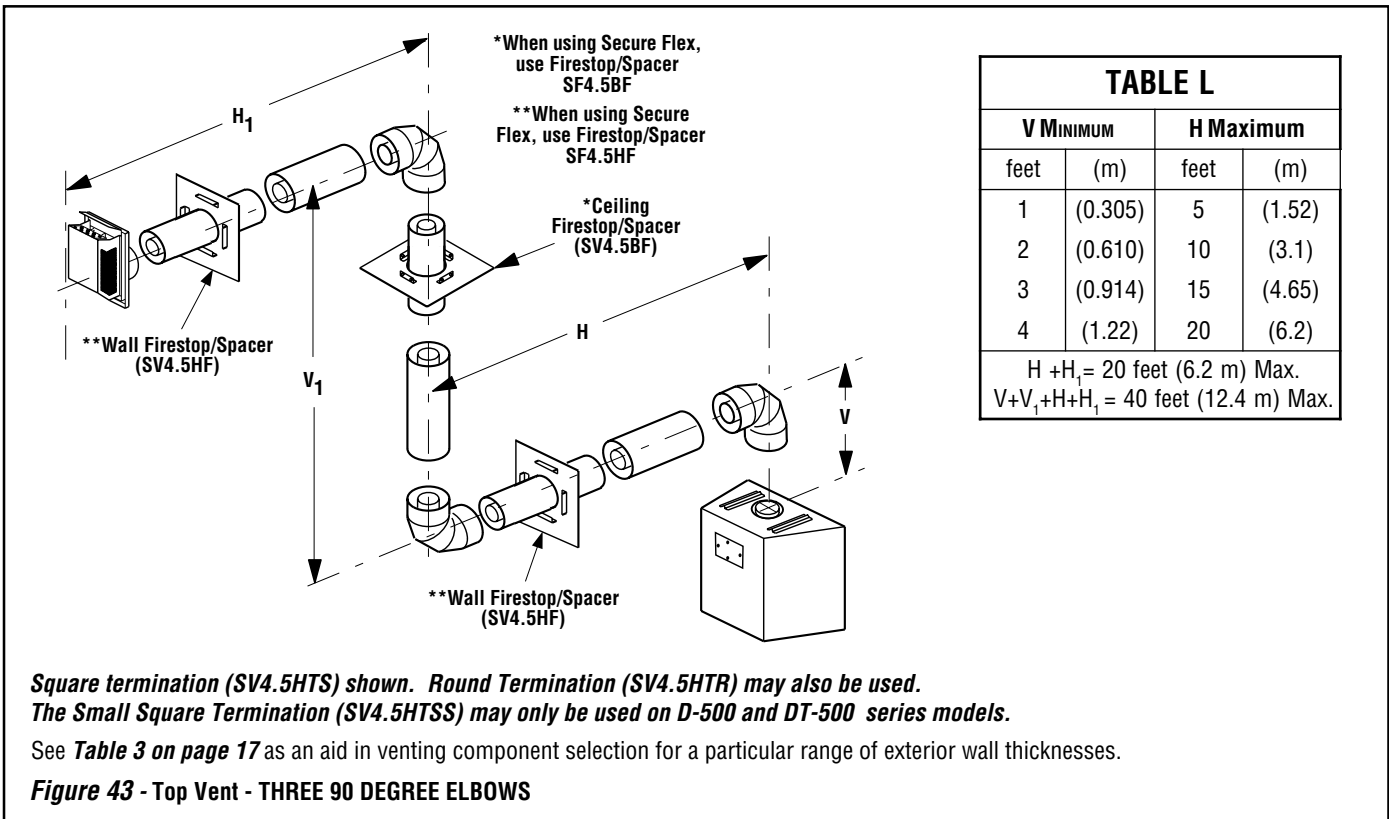
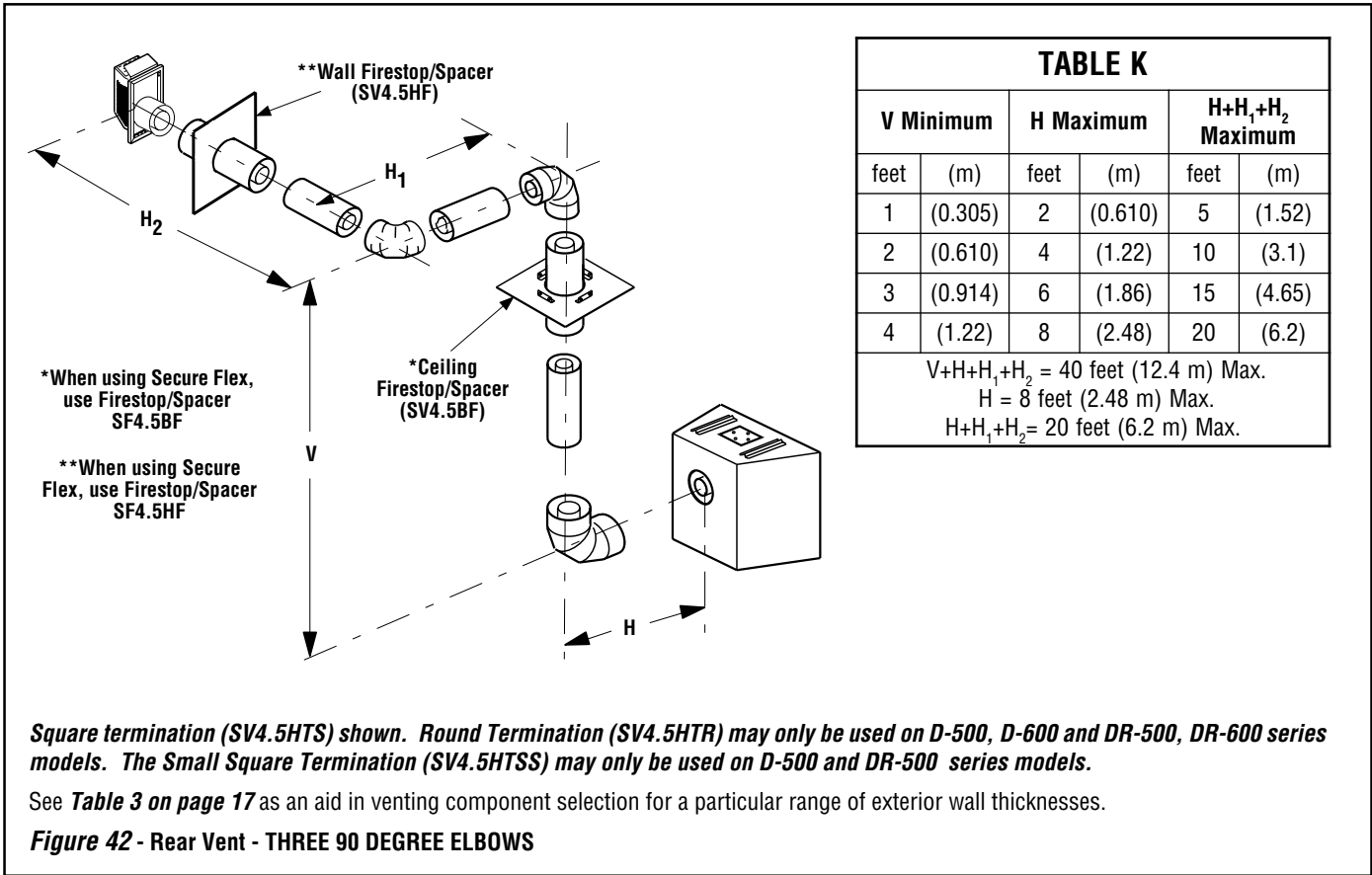

VERTICAL OR HORIZONTAL VENTING USING SECURE FLEX KITS AND COMPONENTS

Secure Flex venting kits and components may be used in any venting application where rigid **Secure Vent** (SV4.5) direct vent components can be used. All restrictions, clearances and allowances that pertain to the rigid piping apply to the flexible venting. **Secure Flex kits may not be modified; also, under no circumstances may separate sections of flex pipe be joined together.** **Secure Flex** kits may be added to the end of a vent run made up of rigid **Secure Vent** (SV4.5) vent sections provided that doing so does not violate any of the venting length, height, routing, horizontal to vertical ratio requirements or clearance considerations detailed in this manual.

Secure Flex kits come with an included adapter that can be fitted to the appliance collar or the inclined channel end of the last **Secure Vent** (SV4.5) vent section in a rigid system in the exact same fashion as any other **Secure Vent** section. Align the dimpled end of the adapter over the previously installed section or appliance collar, adjusting the radial alignment until the four locking dimples of the adapter are aligned with the inlets of the four incline channels of the last vent section or collar. Push on the adapter until it fully engages, then twist the adapter clockwise running the dimples down and along the incline channels until they seat at the end of the channels.

Attach the flexible vent to the adapter as follows (see also Figure 44):

A. Install the Inner Flex Pipe -

1. Install the small gear clamp loosely around the inner flexible vent pipe, push it back out of the way.
2. Apply a bead of **Mill-Pac Black (700°F) high temperature sealant - Catalog No. 10K81** to the inner adapter collar, approximately ½ inches from the end.
3. Pull and extend the inner flexible vent pipe.
4. Slide the inner flex pipe over the adapter collar. Ensure the flexible vent pipe completely engages the adapter collar to a distance of 1¾ inch from the end, and that it is free from damage or tears.
5. Slide the gear clamp down and tighten it fully to secure the flexible vent to the adapter inner collar approximately ¾ inch from the end of the flex.
6. Install **three screws 120 degrees apart** through the flexible vent pipe and into the adapter collar just below the gear clamp to provide additional security to the connection.

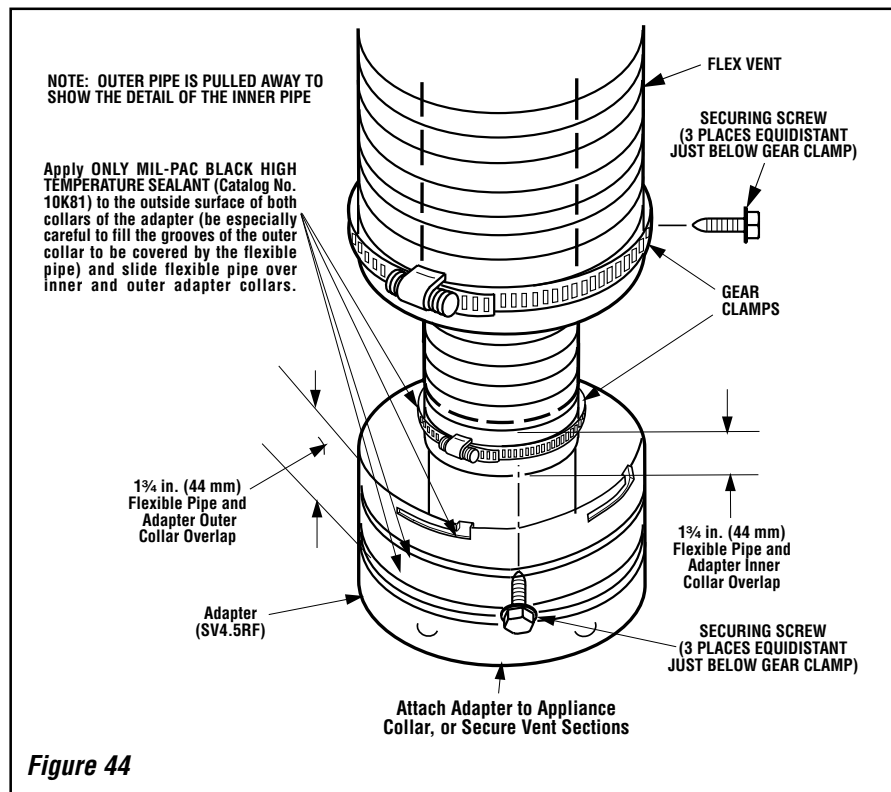

Figure 44

B. Install the Outer Flex Pipe -

1. Install the large gear clamp loosely around the outer flexible vent pipe, push it back out of the way.
2. Apply a bead of **Mill-Pac Black (700°F) high temperature sealant - Catalog No. 10K81** to the outer adapter collar; to the grooves of the collar which extend approximately 1 inch from the end and to the flat surface, approximately 1¾ inches from the end.
3. Pull and extend the outer flexible vent pipe.
4. Slide the outer flex pipe over the adapter collar. Ensure the flexible vent pipe completely engages the adapter collar to a distance of 1¾ inches from the end, and that it is free from damage or tears.
5. Slide the gear clamp down and tighten it fully to secure the flexible vent to the adapter outer collar approximately ¾ inch from the end of the flex.
6. Install **three screws 120 degrees apart** through the flexible vent pipe and into the adapter collar just below the gear clamp to provide additional security to the connection.

C. Route Flex Vent -

Ensure that the flex vent is properly routed to provide the required clearance. Do Not allow the flexible vent to bend in a radius tighter than 5" (127 mm). Refer to **Figure 45**. Support horizontal sections of flex with metal straps at 2 foot (0.61 m) intervals.

SF-12 or SF-18 Flexible Vent Section

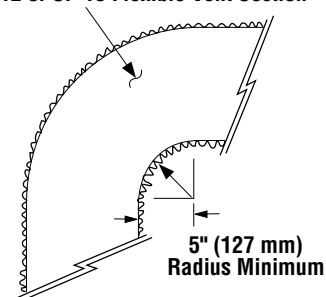

Figure 45

D. Attach Flex Vent to Termination -

Secure Flex components can be purchased separately and attached to bulk lengths of **Secure Flex** flexible tubing cut to size at the job site. When using this method connect the flex vent only to **Flex Vent** terminations, not **Secure Vent** terminations. Secure the flexible vent to the **Secure Flex** terminations in the same manner (see **Figure 44**) as it was attached to the adapter.

Note: Secure Flex vent must be attached to Secure Flex terminations only. DO NOT substitute Secure Vent terminations or the Secure Vent adapter for Secure Flex components. The collars of Secure Flex terminations and adapters have a different circumference than that used with the Secure Vent pipe. Additionally, Secure Flex components have an extended length center tube for use in attaching the flexible vent.

Step 4. FIELD WIRING

Refer to Section A for millivolt appliances and Section B for electronic appliances. The gas valve is set in place and pre-wired at the factory on both models.

A. SIT and Honeywell Millivolt Wiring (See Figure 46) –

1. Select any of the following optional controls: appliance-mounted (rocker switch) or wall-mounted switch, thermostat, or one of the optional remote control kits. If appliance-mounted ON/OFF control is selected mount it in the gas valve mounting bracket.
 2. If wall-mounted ON/OFF control or thermostat is selected mount it in a convenient location on a wall near the fireplace.
 3. Wire the control switch within the millivolt control circuit using the 15 feet of 2 conductor wire supplied with the unit. **Caution: do not connect the optional wall switch to a 120V power supply.**
 4. Alternatively, the appliance may be operated without the use of the controls indicated in step 1, solely by manipulating the gas valve control knob. In order to use this method, twist the free ends of the two conductor wire (located inside the bottom compartment of the unit) together as shown in **Figure 46**.
- Note:** The supplied 15 feet of 2 conductor wire has one end of each conductor connected to the gas valve circuit and the other end of each conductor placed loose inside the bottom compartment of the unit.

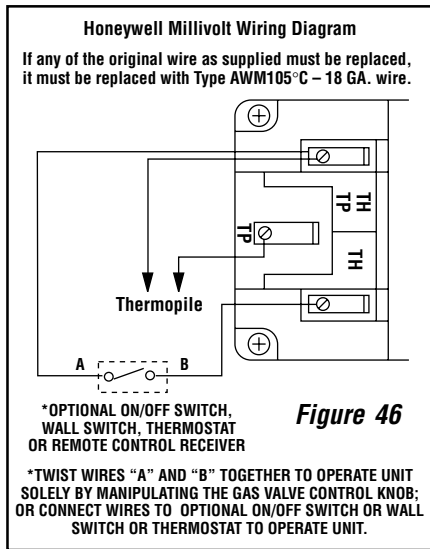

B. Electronic Wiring (See figure 48 or 49) –

Note: The electronic appliance must be connected to the main power supply.

A junction box is located at the rear of the control compartment on either side of the cabinet. The junction box on the right side contains a factory installed and wired outlet box (duplex receptacle). Also, an optional field-provided junction box with receptacle may be installed at the front of the control compartment on either side of the cabinet. **See Figure 47**. It will be held in place by a conduit fitting and locknut (field-provided).

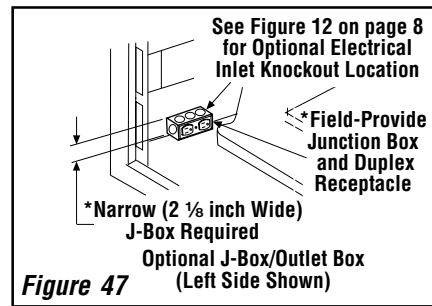

1. Route a 3-wire 120Vac 60Hz 1ph power supply to the appliance junction box.
2. If the factory-provided outlet/junction box at the right rear of the fireplace is being used, remove the outlet box from the junction box by removing two screws.
3. Connect the power supply wires (including the ground supply wire) as shown in **Figures 48 or 49**. (If the field-provided J-box/outlet box is being used, all of the outlet box wiring must be field-provided.)
4. Locate and install a low voltage (24V) wall-mounted switch or thermostat (both field-provided) in the desired location.
5. Connect the low voltage wire (located inside the bottom compartment of the unit) to the wall-mounted switch or thermostat.
6. Insert the control circuit plug into the unswitched receptacle of the outlet box.
7. After wiring is complete, mount the outlet box to the J-Box.

Note: The gas valve-mounted ON/OFF switch is shown in **Figure 48 or 49**. It is integral with the gas valve and should be set to the ON position.

Step 5. WIRING - OPTIONAL FORCED AIR BLOWER KIT FBK-100, FBK-200 and FBK250 Kits (See Figure 48 for FBK-100, FBK-200 and Figure 49 for FBK-250 wiring) -

An electrical outlet box (receptacle) is factory provided for the installation of the **FBK-100, FBK-200 and FBK-250** forced air blower kits. (An optional field-provided outletbox/J-Box may also be used. Electrical power must be connected to either of these receptacles in order to operate these blowers. Install the blower kits according to the installation instructions provided with the kits.

Note: The tab connecting the receptacles of the outlet box must be broken in **FBK-100 and FBK-200** blower kit applications.

IMPORTANT: Ground supply wire must be connected to the green wire attached to the outlet receptacle's green ground screw. See Figure 48 or 49. Failure to do so will result in a potential safety hazard. The appliance must be electrically grounded in accordance with local codes or, in the absence of local codes, the National Electrical Code, ANSI/NFPA 70-(latest edition). (In Canada, the current CSA C22-1 Canadian Electrical Code.)

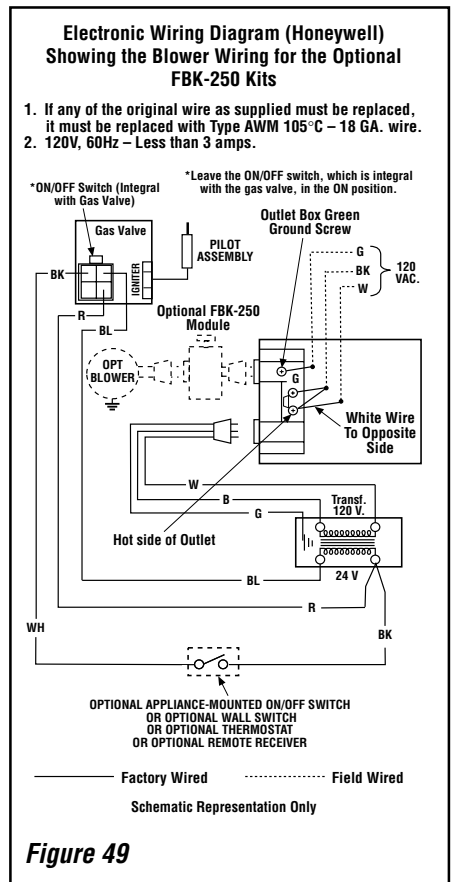
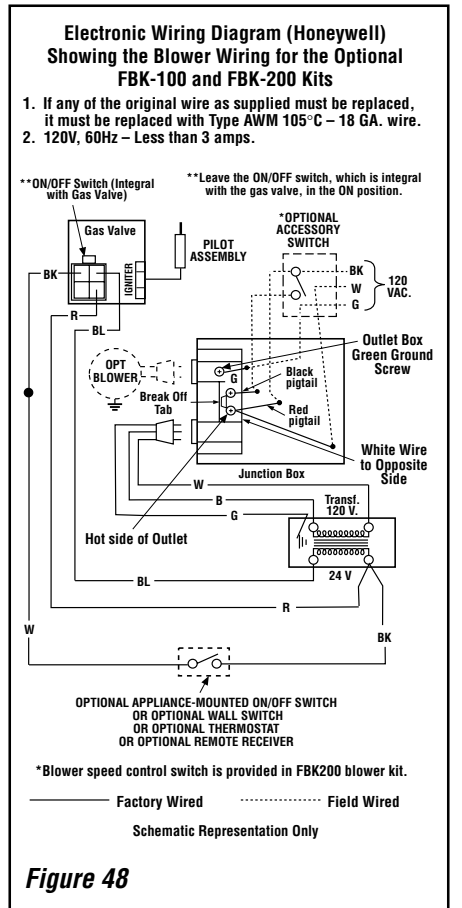

NOTE: DIAGRAMS & ILLUSTRATIONS NOT TO SCALE.

Step 6. CONNECTING GAS LINE

Make gas line connections. All codes require a shut-off valve mounted in the supply line. **Figure 50** illustrates two methods for connecting the gas supply. The flex-line method is acceptable in the U.S., however, Canadian requirements vary depending on locality. Installation must be in compliance with local codes.

These appliances are equipped with a gas flex line for use (where permitted) in connecting the unit to the gas line. A gas flex line is provided to aid in attaching the direct vent appliance to the gas supply. The gas flex line can only be used where local codes permit. See **Figure 50** for flex line description. The flex line is rated for both natural and propane gas. A manual shut off valve is also provided with the flex line.

The gas control valve is located in the lower control compartment. To access the valve open the lower control compartment door (**Figure 51**). The millivolt control valve has a $\frac{3}{8}$ " (10 mm) NPT thread inlet port. The electronic control valve has a $\frac{1}{2}$ " (13 mm) NPT thread inlet port and is fitted with a $\frac{1}{2}$ " x $\frac{3}{8}$ " (13 mm x 10 mm) NPT fitting.

Secure all joints tightly using appropriate tools and sealing compounds (ensure propane resistant compounds are used in propane applications).

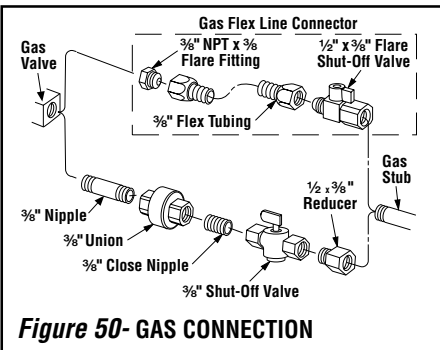

Figure 50- GAS CONNECTION

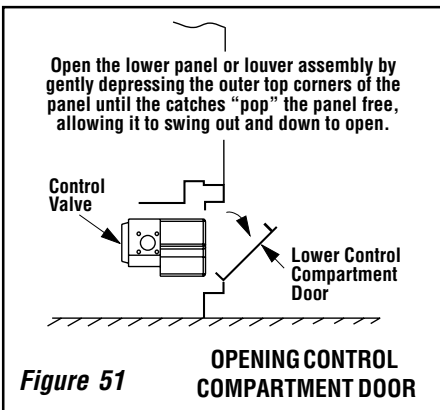

Figure 51

Turn on gas supply and test for gas leaks using a soapy water solution. **Never use an open flame to check for leaks.**

- A. Mix a 50% dish soap, 50% water solution.
- B. Light the appliance (refer to the lighting instructions provided in the Homeowner's Care and Operation Instructions).
- C. Brush all joints and connections with the soapy water solution to check for leaks. If bubbles are formed, or gas odor is detected, turn the gas control knob to the "OFF" position. Either tighten or refasten the leaking connection and retest as described above.
- D. When the gas lines are tested and leak free, observe the individual tongues of flame on the burner. Make sure all ports are open and producing flame evenly across the burner. If any ports are blocked, or partially blocked, clean out the ports.

Step 7. INSTALLING LOGS, DECORATIVE VOLCANIC STONE AND GLOWING EMBERS

The packaged logs are located within the fire-box. The decorative volcanic stone and glowing embers are packaged separately in plastic bags located in the control area of the fireplace. Refer to the **Homeowner's Care and Operation Guide** for detailed placement instructions for decorative volcanic stone, and to the **Log Placement Guide** for detailed placement instructions for logs and glowing embers (rockwool).

Step 8. CHECKING APPLIANCE OPERATION

With gas line installed run initial system checkout before closing up the front of the unit. Follow the pilot lighting instructions provided in the Homeowner's Care and Operation Instructions. For piezo ignitor location see **Figure 52** (SIT and Honeywell millivolt appliances only).

Note: Instructions are also found on the literature tag attached to the gas valve train.

When first lighting the appliance, it will take a few minutes for the line to purge itself of air. Once purging is complete, the pilot and burner will light and operate as indicated in the instruction manual. Subsequent lightings of the appliance will not require such purging. Inspect the pilot flame (remove logs, if necessary, handling carefully).

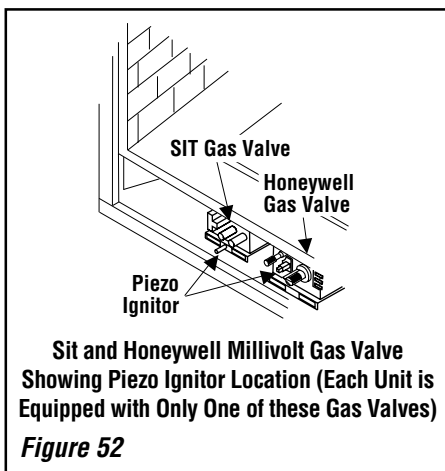

Sit and Honeywell Millivolt Gas Valve Showing Piezo Ignitor Location (Each Unit is Equipped with Only One of these Gas Valves)

Figure 52

SIT and Honeywell Millivolt Appliance Checkout

The pilot flame should be steady, not lifting or floating. Flame should be blue in color with traces of orange at the outer edge. The top $\frac{3}{8}$ " (10 mm) at the pilot generator (thermopile) and the top $\frac{1}{8}$ " min (tip) of the quick drop out thermocouple should be engulfed in the pilot flame. The flame should project 1" (25 mm) beyond the hood at all three ports (**Figure 53 - SIT, Figure 54 - Honeywell**)

Replace logs if removed for pilot inspection.

To light the burner; turn "ON" the remote wall switch and rotate the gas valve control knob counterclockwise to the "ON" position.

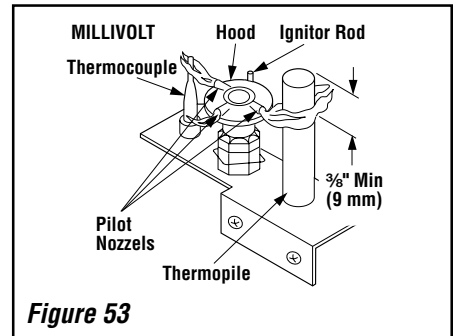

Figure 53

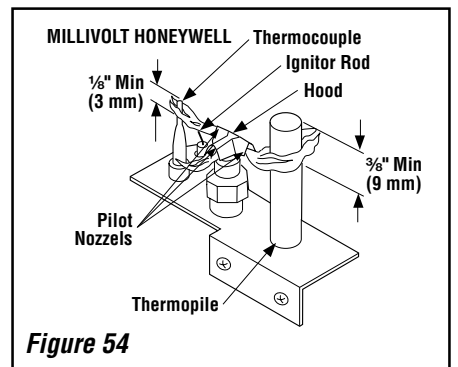

Figure 54

Electronic Appliance Checkout

To light the burner, turn "ON" the optional remote wall switch and turn the gas control switch to the "ON" position. Ensure the ignitor lights the pilot. The pilot flame should engulf the flame rod as shown in **Figure 55**.

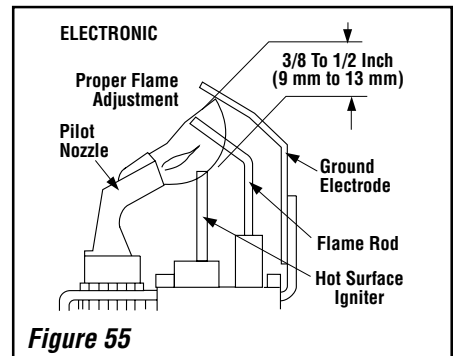

Figure 55

Step 9. INSTALLING THE GLASS DOOR

Retrieve the glass door. Visually inspect the gasket on the backside of the frame. Gasket surface must be clean, free of irregularities and seated firmly.

Position the door in front of the firebox opening with the bottom of the door held away from the fireplace (**Figure 56**). Hook the top flange of the door frame over the top of the firebox frame.

Let the bottom of the door frame swing gently in towards the fireplace ensuring that the gasket seats evenly as the door frame draws shut. Fasten the two latches located underneath the firebox floor to the door's vee-flange. Close both the latches securely.

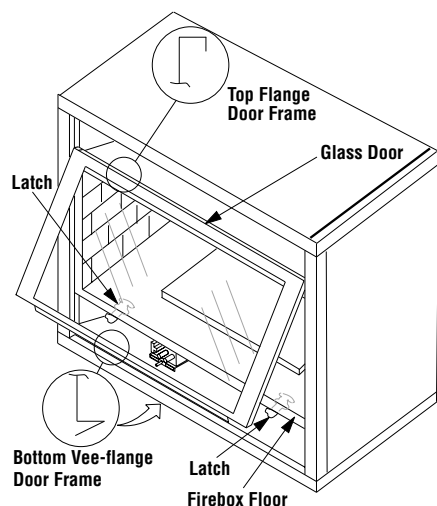

INSTALLING THE GLASS DOOR

Figure 56

WARNING: HANDLE THIS GLASS WITH EXTREME CARE! THE GLASS PANEL IS SUSCEPTIBLE TO DAMAGE—DO NOT SCRATCH WHILE HANDLING OR WHILE RE-INSTALLING THE GLASS DOOR FRAME.

WARNING: NEVER OPERATE THE APPLIANCE WITHOUT THE FRONT GLASS ENCLOSURE PANEL IN PLACE AND SECURE.

Step 10. BURNER ADJUSTMENTS

Flame Appearance and sooting

Proper flame appearance is a matter of taste. Generally, most people prefer the warm glow of a yellow to orange flame.

Appliances operated with air shutter openings that are too large will exhibit flames that are blue and transparent. These weak, blue and transparent flames are termed anemic. If the air shutter opening is too small sooting may develop.

Sooting is indicated by black puffs developing at the tips of very long orange flames. Sooting results in black deposits forming on the logs, appliance inside surfaces and on exterior surfaces adjacent to the vent termination. Sooting is caused by incomplete combustion in the flames and lack of combustion air entering the air shutter opening. To achieve a warm yellow to orange flame with an orange body that does not soot, the shutter opening must be adjusted between these two extremes.

No smoke or soot should be present. Reposition the logs if flames impinge on any of them. If the logs are properly positioned and sooting conditions exist, the air shutter opening on the main burner tube should be adjusted. Normally, the more offsets in the vent system, the greater the need for the air shutter to be opened further.

WARNING: AIR SHUTTER ADJUSTMENT SHOULD ONLY BE PERFORMED BY A QUALIFIED PROFESSIONAL SERVICE TECHNICIAN.

IMPORTANT: ENSURE THAT THE FRONT GLASS PANEL IS IN PLACE AND SEALED DURING ADJUSTMENT.

Burner Adjustment

CAUTION: THE ADJUSTMENT ROD AND NEARBY APPLIANCE SURFACES ARE HOT. EXERCISE CAUTION TO AVOID INJURY WHILE ADJUSTING FLAME APPEARANCE.

To adjust the flame, move the adjustment rod (located in the lower control area) up or down to increase or reduce the air shutter opening, respectively. **Initially, always position the air shutter to the factory setting (the minimum air opening position) as shown in Figure 57. This can be done by pulling the adjustment rod all the way down.** Allow the burner to operate for at least 15 minutes. Observe the flame continuously. If it appears weak or sooty as previously described, adjust the air shutter by pushing or pulling on the adjustment rod until the flame appearance is as desired.

The adjustment rod and associated adjustable air shutter is patented technology. Flame adjustments can be made quickly and accurately to taste without the need of disassembling the appliance and waiting for 30 minutes after each adjustment.

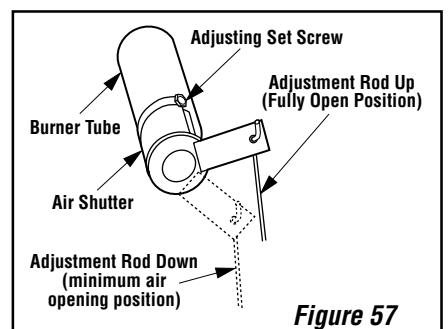

Figure 57

FACTORY AIR SHUTTER SETTING			
inches (mm)			
Models D, DT & DR	Gas Type	Applications using the Appliance Top Vent	Applications using the Appliance Rear Vent
500	Nat.	3/32 (2.38)	3/32 (2.38)
	Prop.	1/8 (3.18)	3/8 (9.52)
600	Nat.	3/32 (2.38)	3/32 (2.38)
	Prop.	3/8 (9.52)	3/8 (9.52)
800	Nat.	3/16 (4.76)	3/16 (4.76)
	Prop.	1/2 (13)	1/2 (13)

Note: If the flame still appears anemic with the air shutter closed all the way against the stop (usually a result of lengthy vertical runs), turn the appliance off, turn the gas supply off, wait for the parts to cool, remove the glass door and logs to access the air shutter. The shutter is prevented from actually closing all the way by an adjustment set screw (see Figure 57). Remove this screw using a 1/4 inch nut driver. Reinstall the logs and glass door, turn the gas back on and then restart the appliance. After 30 minutes, reobserve the flame. Adjust the air shutter as previously described.

When satisfied that the appliance operates properly, proceed to finish the installation. Leave the control knob in the ON position and the remote switch OFF. Close the lower control compartment door.

Step 11. HOOD INSTALLATION

All of these appliances must have hoods installed prior to operating.

On all clean face units, slide the hood into the slots on the lower edge of the radiant panel (**Figure 58 on page 24**). On louvered face units, slide the hood into the slots on the lower edge of the cabinet top (**Figure 59 on page 24**).

FINISHING REQUIREMENTS

Wall Details

Complete finished interior wall. To install the appliance facing flush with the finished wall, position framework to accommodate the thickness of the finished wall (**Figure 58, and Figure 59 on page 24**).

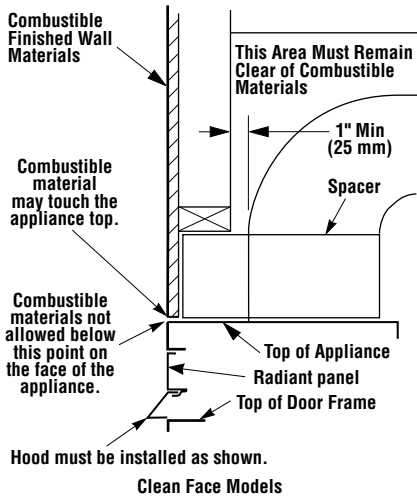

Figure 58

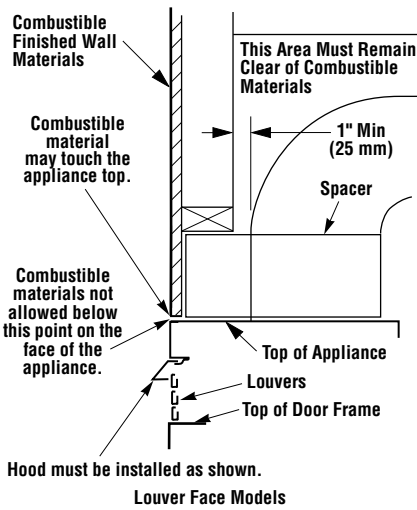

Figure 59

Combustible materials may project beyond the sides of the fireplace opening as long as they are kept within the shaded areas illustrated in **Figure 60**.

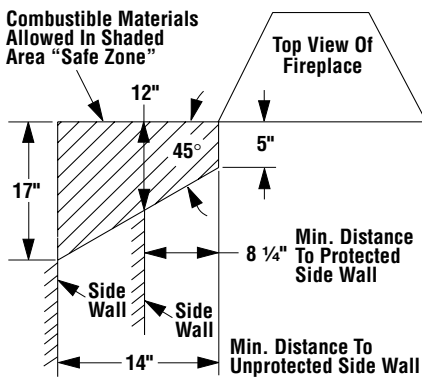

Figure 60

MANTEL CLEARANCES

Inches (mm)

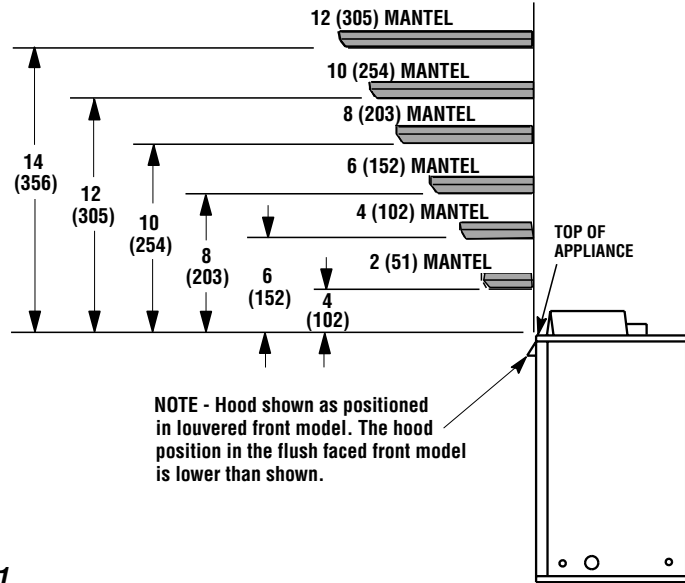

Figure 61

A hearth extension is not required with this appliance. If a hearth extension is used, do not block the lower control compartment door. Any hearth extension used is for appearance only and does not have to conform to standard hearth extension installation requirements.

Note: Combustible wall finish materials and/or surround materials must not be allowed to encroach the area defined by the appliance front face (black sheet metal). **Never allow combustible materials to be positioned in front of or overlapping the appliance front face.** See **Figure 58** and **Figure 59**.









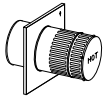

Non-combustible materials, such as surrounds and other appliance trim, may be installed on the appliance front face with these exceptions: they must not cover any portion of the glass or louvers; they may cover any portion of the top radiant panel or the air gaps surrounding the top radiant panel up to the installed hood.

Vertical installation clearances to combustible mantels vary according to the depth of the mantel. See **Figure 61**. Mantels constructed of non-combustible materials may be installed at any height above the appliance opening; however, do not allow anything to hang below the hood.

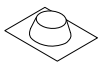

COLD CLIMATE INSULATION

If you live in a cold climate, seal all cracks around your appliance with noncombustible material and wherever cold air could enter the room. It is especially important to insulate outside chase cavity between studs and under floor on which appliance rests, if floor is above ground level.

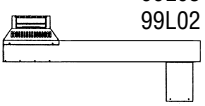
INSTALLATION ACCESSORIES

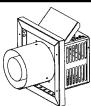
Listed Secure Vent™ Components			
	Cat. No.	Model No.	Description
	86L95	SV4.5HTR	Horizontal Round Termination with Firestop/Spacer (96K80) and Adapter (74L61)
	86L97	SV4.5HTS	Horizontal Square Termination with Firestop/Spacer (96K80) and Adapter (74L61)
	H2152	SV4.5CGV-1	Vertical Termination
	77L70	SV4.5L6	6 inch (152 mm) Vent Section
	77L71	SV4.5L12	12 inch (305 mm) Vent Section
	77L72	SV4.5L24	24 inch (610 mm) Vent Section
	77L73	SV4.5L36	36 inch (914 mm) Vent Section
	77L74	SV4.5L48	48 inch (1219 mm) Vent Section
	77L75	SV4.5LA	Telescopic Section
	77L76	SV4.5E45	45 Degree Elbow
	77L77	SV4.5E90	90 Degree Elbow
The following flashings come packaged with a storm collar.			
	77L78	SV4.5F	Flat Roof Flashing
	77L79	SV4.5FA	1/12 to 7/12 Adjust. Flashing
	77L80	SV4.5FB	7/12 to 12/12 Adjust. Flashing
	77L81	SV4.5SC6	Storm Collars (6 collars/box)
	96K80	SV4.5HF	Firestop/Spacer - Horizontal (3-1-1 spacing)
	96K87	SV4.5BF	Firestop/Spacer - Vertical (1-1-1 spacing)
	96K93	SV4.5SU	Support Strap
	96K94	SV4.5RSA	Attic Insulation Shield
	99L03	SV4.5HRK36	Horizontal Riser Kit 36"
	99L02	SV4.5HRK14	Horizontal Riser Kit 14"

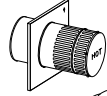
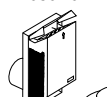
Listed Secure Vent™ Components for use with D-500, DT-500 and DR-500 models Only			
	Cat. No.	Model No.	Description
	94L10	SV4.5HTSS	Horizontal Small Square Termination with Firestop/Spacer (96K80) and Adapter (74L61)



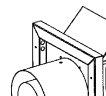

Listed Secure Flex™ Components			
	Cat. No.	Model No.	Description
These termination kits include firestop/spacer, gear clamps and flex adapter.			
	86L94	SF-HTR	Horizontal Round Termination without Flex
	77L82	SFKIT12R	Flex Round Term. with 12 in. (305 mm) of *compressed Flex
	77L83	SFKIT18R	Flex Round Term. with 18 in. (457 mm) of *compressed Flex
	77L84	SFKIT24R	Flex Round Term. with 24 in. (610 mm) of *compressed Flex
	77L85	SFKIT36R	Flex Round Term. with 36 in. (914 mm) *compressed Flex
	77L86	SFKIT48R	Flex Round Term. with 48 in. (1219 mm) of *compressed Flex
These termination kits include firestop/spacer, gear clamps and flex adapter.			
	86L96	SF-HTS	Horizontal Square Termination without Flex
	77L87	SFKIT12S	Flex Square Term. with 12 in. (305 mm) of *compressed Flex
	77L88	SFKIT18S	Flex Square Term. with 18 in. (457 mm) of *compressed Flex
	77L89	SFKIT24S	Flex Square Term. with 24 in. (610 mm) of *compressed Flex
	77L90	SFKIT36S	Flex Square Term. with 36 in. (914 mm) of *compressed Flex
	77L91	SFKIT48S	Flex Square Term. with 48 in. (1219 mm) of *compressed Flex
	56L74	SFVT30	Vertical Termin. for Flex (flat to 6/12) with Flex Adapter, section of rigid vent, roof support collar assembly, roof flashing and storm collar.
	56L75	SFVT45	Vertical Termin. for Flex (6/12 to 12/12) with Flex Adapter section of rigid vent, roof support collar assembly, roof flashing and storm collar.
	60L10	SF-18	18 ft. (5.49 m) *compressed Flex
	98K03	SF-12	12 ft. (3.66 m) *compressed Flex

Listed Secure Flex™ Components for use with D-500, DT-500 and DR-500 models only			
	Cat. No.	Model No.	Description
These termination kits include firestop/spacer, gear clamps and flex adapter.			
	94L09	SF-HTSS	Horizontal Small Square Termination without Flex
	94L04	SFKIT12SS	Flex Small Square Term. with 12 in. (305 mm) of *compressed Flex
	94L05	SFKIT18SS	Flex Small Square Term. with 18 in. (457 mm) of *compressed Flex
	94L06	SFKIT24SS	Flex Small Square Term. with 24 in. (610 mm) of *compressed Flex
	94L07	SFKIT36SS	Flex Small Square Term. with 36 in. (914 mm) of *compressed Flex
	94L08	SFKIT48SS	Flex Small Square Term. with 48 in. (1219 mm) of *compressed Flex

*All compressed flex vents can be expanded up to two times.



NOTE: DIAGRAMS & ILLUSTRATIONS NOT TO SCALE.

INSTALLATION ACCESSORIES CONTINUED

Listed Secure Vent™ Components			
	Cat. No.	Model No.	Description
	96K92	SV4.5SP	Support Plate
	97K00	SV4.5HGR	Heat Guard Round
	17M52	SV4.5 HGS-1	Heat Guard Square (1 - Pack)
	17M53	SV4.5 HGS-12	Heat Guard Square (12 - Pack)
	96K98	SV4.5HDR	Heat Deflector for Round Termination

GAS CONVERSION KITS

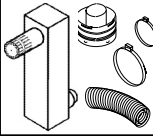
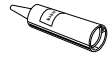
WARNING: THIS CONVERSION KIT SHALL BE INSTALLED BY A QUALIFIED SERVICE AGENCY IN ACCORDANCE WITH THE MANUFACTURER'S INSTRUCTIONS AND ALL APPLICABLE CODES AND REQUIREMENTS OF THE AUTHORITY HAVING JURISDICTION. IF THE INFORMATION IN THESE INSTRUCTIONS IS NOT FOLLOWED EXACTLY, A FIRE, EXPLOSION OR PRODUCTION OF CARBON MONOXIDE MAY RESULT CAUSING PROPERTY DAMAGE, PERSONAL INJURY OR LOSS OF LIFE. THE INSTALLATION IS NOT PROPER AND COMPLETE UNTIL THE OPERATION OF THE CONVERTED APPLIANCE IS CHECKED AS SPECIFIED IN THE OWNER INSTRUCTIONS SUPPLIED WITH THE KIT. THE QUALIFIED SERVICE AGENCY PERFORMING THIS INSTALLATION ASSUMES RESPONSIBILITY FOR THIS CONVERSION.

Listed Secure Flex™ Components			
	Cat. No.	Model No.	Description
	87L01	SFHRK	Snorkel Riser Kit with Flex Adapter, a section of Flex, and Gear Clamps
	10K81	SFMP	Mil Pac Black Hi-Temperature Sealant
	91L66	SF-GC4-6	Gear Clamp 4.5in. (114 mm) for Flex (6 pieces)
	91L67	SF-GC7-6	Gear Clamp 7.5 in. (190.5 mm) for Flex (6 pieces)
	19M40	SF4.5HF	Firestop/Spacer - Horizontal (3-1-1 spacing)
	19M41	SF4.5BF	Firestop/Spacer - Vertical (1-1-1 spacing)

AVERTISSEMENT: CET ÉQUIPEMENT DE CONVERSION SERA INSTALLÉ PAR UNE AGENCE QUALIFIÉE DE SERVICE CONFORMÉMENT AUX INSTRUCTIONS DU FABRICANT ET TOUTES EXIGENCES ET CODES APPLICABLES DE L'AUTORISÉ AVOIR LA JURIDICTION. SI L'INFORMATION DANS CETTE INSTRUCTION N'EST PAS SUIVIE EXACTEMENT, UN FEU, EXPLOSION OU PRODUCTION DE PROTOXYDE DE CARBONE PEUT RÉSULTER LE DOMMAGES CAUSER DE PROPRIÉTÉ, PERTE OU BLESSURE PERSONNELLE DE VIE. L'AGENCE QUALIFIÉE DE SERVICE EST ESPONSABLE DE L'INSTALLATION PROPRE DE CET ÉQUIPEMENT. L'INSTALLATION N'EST PAS PROPRE ET COMPLÈTE JUSQU'À L'OPÉRATION DE L'APPAREIL CONVERTI EST CHÉQUE SUIVANT LES CRITÈRES ÉTABLIS DANS LES INSTRUCTIONS DE PROPRIÉTAIRE PROVISIONNÉES AVEC L'ÉQUIPEMENT.

In Canada:

THE CONVERSION SHALL BE CARRIED OUT IN ACCORDANCE WITH THE REQUIREMENTS OF THE PROVINCIAL AUTHORITIES HAVING JURISDICTION AND IN ACCORDANCE WITH THE REQUIREMENTS OF THE CAN1-B149.1 AND .2 INSTALLATION CODE.

LA CONVERSION DEVRA ÊTRE EFFECTUÉE CONFORMÉMENT AUX RECOMMANDATIONS DES AUTORITÉS PROVINCIALES AYANT JURIDICTION ET CONFORMÉMENT AUX EXIGENCES DU CODE D'INSTALLATION CAN1-B149.1 ET.2.

Gas conversion kits are available to adapt your appliance from the use of one type of gas to the use of another. These kits contain all the necessary components needed to complete the task including labeling that must be affixed to ensure safe operation.

Kit part numbers are listed here and the following steps detail the conversion procedure.

Millivolt SIT Systems - Natural To Propane Gas Conversion Kits		
D, DT, DR Series	Unit Type	Catalog No.
500	millivolt	85L59
600	millivolt	85L60
800	millivolt	85L61

Honeywell Systems - Natural To Propane Gas Conversion Kits		
D, DT, DR Series	Unit Type	Catalog No.
500	millivolt	11M37
600	millivolt	11M38
800	millivolt	11M39
500	electronic	85L73
600	electronic	85L74
800	electronic	85L75

Millivolt SIT Systems - Propane to Natural Gas Conversion Kits		
D, DT, DR Series	Unit Type	Catalog No.
500	millivolt	85L66
600	millivolt	85L67
800	millivolt	85L68

Honeywell Systems - Propane to Natural Gas Conversion Kits		
D, DT, DR Series	Unit Type	Catalog No.
500	millivolt	11M34
600	millivolt	11M35
800	millivolt	11M36
500	electronic	85L80
600	electronic	85L81
800	electronic	85L82

NOTE: DIAGRAMS & ILLUSTRATIONS NOT TO SCALE.

Step 1. Turn off the gas supply to the appliance. Remove the front glass door/frame from the appliance. Access the control compartment.

Step 2. Carefully remove the logs. **Exercise care so as not to break the logs.**

Step 3. Locate the screws securing the burner (tray) to the appliance. Remove the burner and retain the securing screws.

Step 4. Millivolt Appliances - SIT Systems

a. Refer to **Figure 62** and the instructions provided with the kit. Using a Torx T20, remove and discard the three pressure regulator mounting screws. Remove the pressure regulator, spring, poppet, diaphragm and bushing. **Discard all removed components.** Ensure the rubber gasket installed on the back of the replacement pressure regulator is properly positioned and install the new pressure regulator using the new screws supplied with the kit. Tighten screws to 25 In. lb. torque.

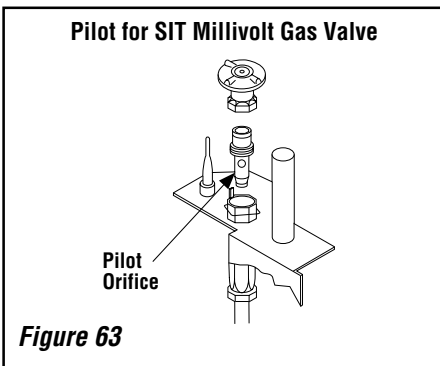
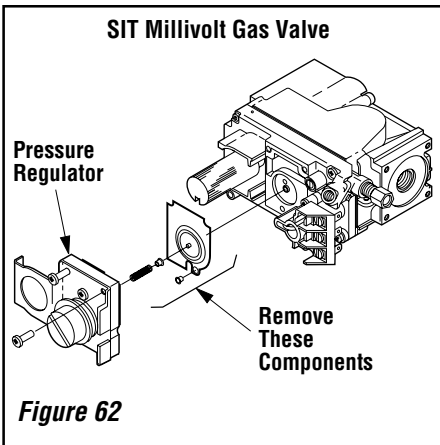

b. Attach manometer to the manifold side pressure test fitting and verify manifold pressure reads 3.5 inches water column (0.87 kPa) for natural gas, and 10.0 inches water column (2.49 kPa) for propane gas.

c. Refer to **Figure 63** and remove the pilot hood assembly to access the hexed pilot orifice. Remove and replace the orifice with the one provided with the kit.

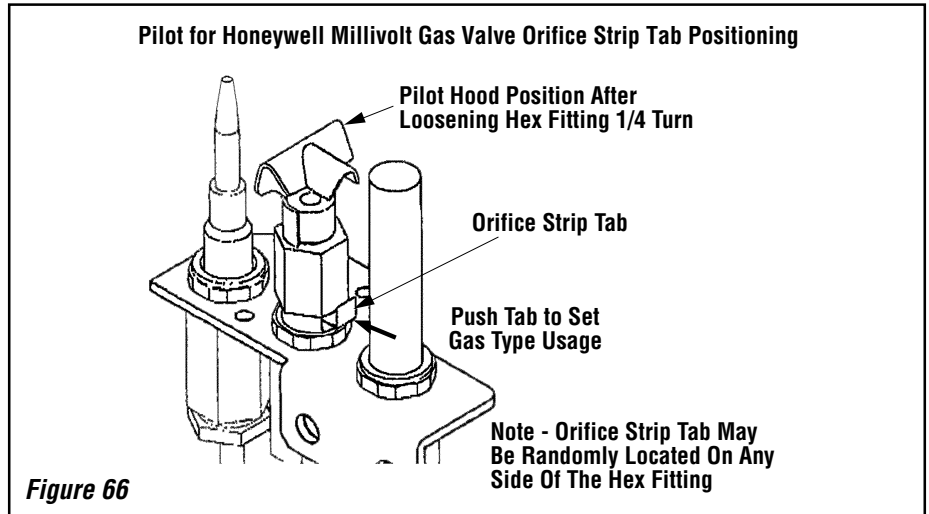
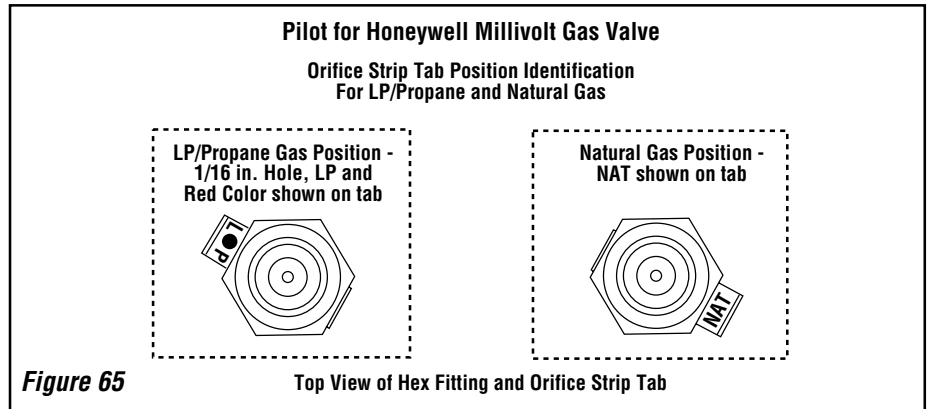
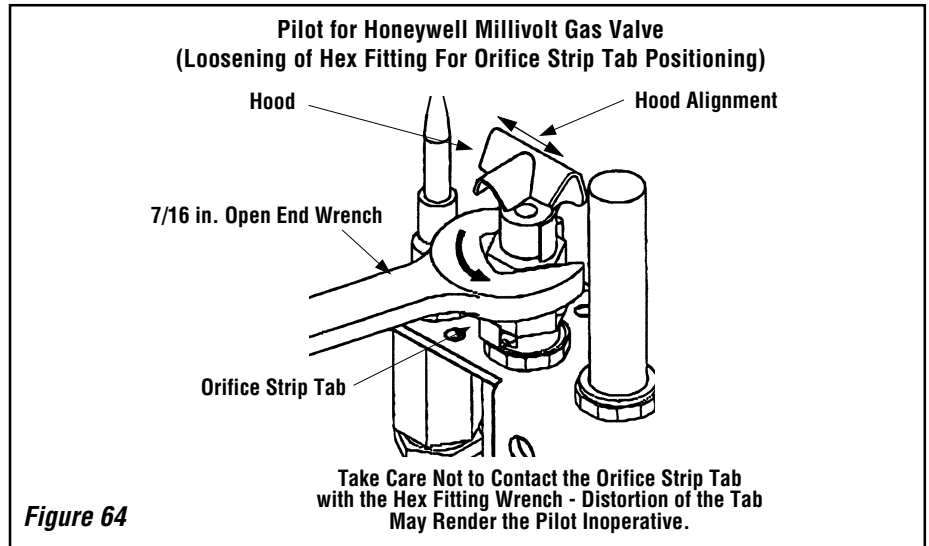

Step 5. Millivolt Appliances - Honeywell Systems

a. Convert the gas valve as follows (see **Figure 67**): Remove the plastic protecting cap. Remove the gas type setting screw by turning it counter-clockwise. Obtain the replacement gas type setting screw from the kit and screw it into place (red for propane and blue for natural gas). Tighten the gas type setting screw by turning it clockwise. Replace the plastic protecting cap.

Honeywell Millivolt Gas Valve

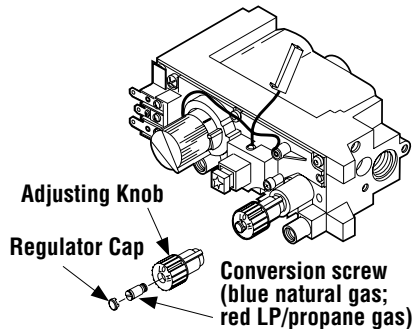

Figure 67

b. Attach manometer to the manifold side pressure test fitting and verify manifold pressure reads 3.5 inches water column (0.87 kPa) for natural gas, and 10.0 inches water column (2.49 kPa) for propane gas.

c. Convert the pilot orifice as follows (refer to **Figures 64, 65 and 66**):

Note - Use extra care not to engage the orifice strip with the 7/16" open end wrench (contacting the orifice strip could cause strip distortion rendering the pilot inoperative). Also avoid wrench contact to any of the other pilot parts.

Use a 7/16" open end wrench and turn the pilot hex fitting counter-clockwise 1/4 turn. (refer to **Figure 64**).

Note - The orifice strip tab may be randomly located on any side of the hex fitting.

d. Push the orifice strip tab all the way against the hex fitting to align the appropriate gas type orifice (refer to **Figures 65 and 66**). The type of gas for which the pilot is set, is, the gas type shown on the tab.

e. Retighten, clockwise, the pilot hex fitting until the pilot hood aligns with the thermocouple and thermopile as indicated by the arrows shown in **Figure 64**.

Step 6. Electronic Appliances - Honeywell Systems

See **Figure 68** and the instructions provided with the kit. Remove the slotted cap screw, o-ring, pressure-regulating adjusting screw and spring. Retain all parts for possible later use. Install new components from the kit. Black cap and red spring for propane gas units. Silver cap and stainless steel spring for natural gas units. Before installing the cap, attach manometer to the manifold side pressure test fitting and adjust screw until pressure reads 3.5 inches water column (0.87 kPa) for natural gas, and 10.0 inches water column (2.49 kPa) for propane gas.

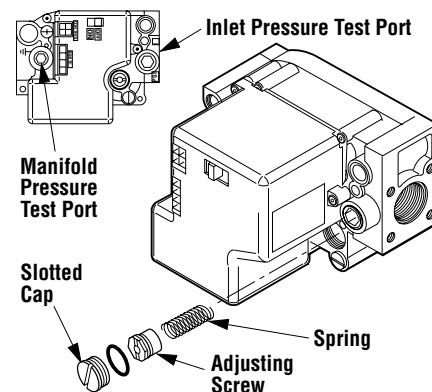
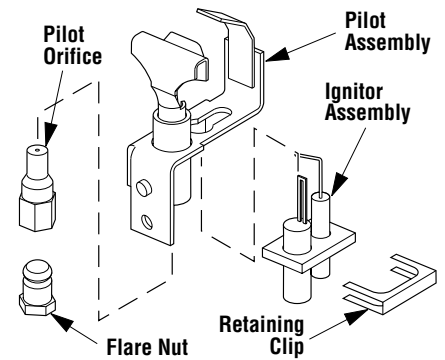

Figure 68

See **Figure 69** and replace the pilot orifice as follows: Remove the ignitor assembly retainer clip, and carefully remove the ignitor assembly. **Exercise extreme care to prevent damage to or breakage of the ignitor assembly.** Remove the screw securing the pilot assembly to its mounting bracket. Back off the flare nut at the end of the pilot gas line to free the pilot assembly from the gas line.

Remove the pilot orifice and replace it with the one provided with the conversion kit. Reinstall the pilot assembly by reversing the **steps** detailed here.

When reinstalling the ignitor assembly, use extreme care to prevent damage and breakage. Do not apply any leverage to the ignitor assembly while restoring the retainer clip to its original position.



Note: If the ignitor is damaged, a replacement kit is available - order Catalog Number 87L54.

Figure 69

All Models

Step 7. Remove the orifice from the manifold and replace it with the one provided with the kit. See the following table for orifice sizes for natural and propane models. **Figure 70** illustrates the orifice.

D, DT, DR Series	Orifice Size	
	Natural	Propane
500	0.090 in.	#54
600	#36	#52
800	#33	0.065 in.

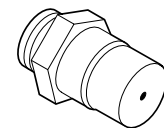

Figure 70

Step 8. Reassemble all removed components by reversing the procedures outlined in the preceding steps. Use pipe joint compound or Teflon tape on all pipe fittings before installing (ensure propane resistant compounds are used in propane applications, do not use pipe joint compounds on flare fittings).

Step 9. Attach the conversion label provided in the conversion kit to the rating plate on the appliance.

Step 10. Turn on gas supply and test for gas leaks.

NOTE: DIAGRAMS & ILLUSTRATIONS NOT TO SCALE.

The manufacturer reserves the right to make changes at any time, without notice, in design, materials, specifications, prices and also to discontinue colors, styles and products. Consult your local distributor for fireplace code information.