

1. PRECAUTIONS FOR USE .....	44
2. RECYCLING INSTRUCTIONS - OUR ENVIRONMENT POLICY .....	45
3. SAFETY PRECAUTIONS .....	46
4. INTENDED USE .....	46
5. GETTING TO KNOW YOUR COOKER .....	47
6. BEFORE INSTALLATION .....	47
7. DESCRIPTION OF FRONT PANEL CONTROLS .....	48
8. USING THE HOB .....	50
8.1 Cooking zones .....	50
9. USING THE OVEN .....	51
9.1 Precautions and General Advice .....	51
9.2 Cooling fan system .....	51
9.3 Using the electric grill .....	51
9.4 Using the grill .....	52
9.5 Attention .....	52
9.6 Storage compartment .....	52
10. ACCESSORIES AVAILABLE .....	53
11. ELECTRONIC PROGRAMMER .....	54
11.1 Setting the time .....	54
11.2 Semiautomatic cooking .....	54
11.3 Automatic cooking .....	54
11.4 End of cooking .....	54
11.5 Timer .....	55
11.6 Adjusting the buzzer volume .....	55
11.7 Stopping the buzzer .....	55
11.8 Deleting the data set .....	55
11.9 Modifying the data set .....	55
12. CLEANING AND MAINTENANCE .....	56
12.1 Cleaning stainless steel .....	56
12.2 Routine daily cleaning .....	56
12.3 Food stains or spills .....	56
12.4 Cleaning the ceramic hob .....	56
12.5 Cleaning the oven .....	57
12.6 Cleaning the door glazing .....	57
12.7 Pyrolysis: automatic oven cleaning .....	57
12.8 Before starting the automatic cleaning cycle .....	57
12.9 Setting the automatic cleaning cycle .....	58
13. EXTRAORDINARY MAINTENANCE .....	59
13.1 Changing the light bulb .....	59
13.2 Removing the door .....	59
13.3 Removing the gasket .....	59
14. INSTALLING THE APPLIANCE .....	60
14.1 Electrical connection .....	60
14.2 Fitting the rear splash-back .....	62
14.3 Positioning and levelling the appliance (depending on model) .....	62



**INSTRUCTIONS FOR THE USER:** these provide recommendations for use, a description of the controls and the correct procedures for cleaning and maintaining the appliance.



**INSTRUCTIONS FOR THE INSTALLER:** these are intended for the qualified engineer who is to perform a thorough check on the gas circuit and install, commission and test the appliance.

## 1. PRECAUTIONS FOR USE



THIS MANUAL IS AN INTEGRAL PART OF THE APPLIANCE. TAKE GOOD CARE OF IT AND KEEP IT TO HAND THROUGHOUT THE COOKER'S LIFE CYCLE. WE URGE YOU TO READ THIS MANUAL AND ALL THE INFORMATION IT CONTAINS CAREFULLY BEFORE USING THE APPLIANCE. ALSO KEEP ALL THE NOZZLES PROVIDED IN A SAFE PLACE. INSTALLATION MUST BE CARRIED OUT BY QUALIFIED STAFF IN COMPLIANCE WITH THE RELEVANT REGULATIONS. THIS APPLIANCE IS INTENDED FOR HOUSEHOLD USE AND COMPLIES WITH THE **RELEVANT REGULATIONS**. THE APPLIANCE IS BUILT TO PROVIDE THE FOLLOWING FUNCTION: **COOKING AND HEATING FOODS**; ALL OTHER USES ARE TO BE CONSIDERED IMPROPER. THE MANUFACTURER DECLINES ALL LIABILITY FOR USES OTHER THAN THOSE STATED ABOVE.



NEVER USE THIS APPLIANCE FOR HEATING ROOMS.



NEVER LEAVE PACKAGING RESIDUES UNATTENDED IN THE HOME. SEPARATE WASTE PACKAGING MATERIALS BY TYPE AND CONSIGN THEM TO THE NEAREST SEPARATE DISPOSAL CENTRE.



THIS APPLIANCE IS TAGGED UNDER EUROPEAN DIRECTIVE 2002/96/EC ON WASTE ELECTRICAL AND ELECTRONIC EQUIPMENT (WEEE). THIS DIRECTIVE CONTAINS THE REGULATIONS GOVERNING THE COLLECTION AND RECYCLING OF DECOMMISSIONED APPLIANCES THROUGHOUT THE EUROPEAN UNION.



NEVER OBSTRUCT THE OPENINGS AND SLITS PROVIDED FOR VENTILATION AND HEAT DISPERSAL.



THE NAMEPLATE WITH THE TECHNICAL DATA, SERIAL NUMBER AND MARK IS IN A VISIBLE POSITION INSIDE THE STORAGE COMPARTMENT. **THE NAMEPLATE MUST NEVER BE REMOVED.**



REMOVE ALL REMOVABLE LABELS AND PROTECTIVE FILMS FROM THE INSIDE AND OUTSIDE OF THE APPLIANCE.



NEVER USE METAL SCOURING PADS OR SHARP SCRAPERS; THEY WILL DAMAGE SURFACES.



USE ORDINARY NON-ABRASIVE PRODUCTS FOR STEEL, WITH THE AID OF WOODEN OR PLASTIC UTENSILS IF NECESSARY.

RINSE THOROUGHLY AND DRY WITH A SOFT CLOTH OR CHAMOIS LEATHER.



DO NOT ALLOW SPILLS OF FOODS WITH HIGH SUGAR CONTENT (E.G. JAM) TO DRY INSIDE THE OVEN. IF THEY DRY FOR TOO LONG, THEY MIGHT DAMAGE THE ENAMEL COATING OF THE INSIDE OF THE OVEN.



**THE MANUFACTURER DECLINES ALL RESPONSIBILITY FOR INJURY OR DAMAGE CAUSED BY FAILURE TO COMPLY WITH THE ABOVE REGULATIONS OR DERIVING FROM TAMPERING WITH EVEN JUST ONE PART OF THE APPLIANCE AND THE USE OF NON-ORIGINAL SPARE PARTS.**



### **2. RECYCLING INSTRUCTIONS - OUR ENVIRONMENT POLICY**

Our household appliances are only packaged using non-pollutant, environment-friendly, recyclable materials. We urge you to cooperate by disposing of the packaging properly. Contact your local dealer or the competent local organisations for the addresses of collection, recycling and disposal facilities.

Never leave all or part of the packaging lying around. Packaging parts, and especially plastic bags, may represent a suffocation hazard for children.

Your old appliance must also be disposed of properly.

**Important:** deliver the appliance to your local organisation authorised to collect scrapped appliances.

Proper disposal allows the intelligent recovery of valuable materials. Refrigeration appliances contain gases which may damage the environment; it is therefore important to ensure that the refrigeration circuit pipelines are not damaged until the competent service has taken delivery of the appliance.

Before scrapping your appliance it is important to remove doors and leave shelves in position as for use, to ensure that children cannot accidentally become trapped inside during play. Also, cut the power supply lead and remove it and the plug.

### 3. SAFETY PRECAUTIONS



ELECTRICAL CONNECTION: REFER TO THE INSTALLATION INSTRUCTIONS WITH REGARD TO GAS, ELECTRICITY SUPPLY AND VENTILATION REQUIREMENTS.

IN YOUR INTEREST AND TO ENSURE YOUR SAFETY, BY LAW ALL GAS-FIRED HOUSEHOLD APPLIANCES MUST ONLY BE INSTALLED AND SERVICED BY QUALIFIED STAFF, IN ACCORDANCE WITH THE RELEVANT REGULATIONS.

INSTALLATION TECHNICIANS ARE COMMITTED TO WORKING TO THE HIGHEST STANDARDS. GAS OR ELECTRIC APPLIANCES MUST ALWAYS BE DISCONNECTED BY SUITABLY SKILLED PEOPLE.



THE PLUG TO BE CONNECTED TO THE POWER SUPPLY LEAD AND THE RELATIVE SOCKET MUST BE OF THE SAME TYPE AND COMPLY WITH THE RELEVANT REGULATIONS.

THE POWER SUPPLY SOCKET MUST BE ACCESSIBLE EVEN AFTER THE APPLIANCE HAS BEEN BUILT-IN.

**NEVER DISCONNECT THE PLUG BY PULLING ON THE POWER SUPPLY LEAD.**



**THIS APPLIANCE MUST NEVER BE INSTALLED ON A STAND.**



THE APPLIANCE MUST BE CONNECTED TO EARTH IN COMPLIANCE WITH ELECTRICAL SYSTEM SAFETY REGULATIONS.



IMMEDIATELY AFTER INSTALLATION, CARRY OUT A QUICK TEST ON THE APPLIANCE FOLLOWING THE INSTRUCTIONS PROVIDED LATER IN THIS MANUAL. IF THE APPLIANCE FAILS TO OPERATE, DISCONNECT IT FROM THE ELECTRICAL MAINS AND CONTACT YOUR NEAREST SERVICE CENTRE.

**NEVER ATTEMPT TO REPAIR THE APPLIANCE YOURSELF.**



**NEVER PLACE PANS WITH BOTTOMS WHICH ARE NOT PERFECTLY FLAT AND SMOOTH ON THE HOB GRIDS.**



**WARNING:** IF YOU NOTICE A CRACK IN THE CERAMIC HOB, DISCONNECT IT FROM THE ELECTRICITY SUPPLY IMMEDIATELY AND CONTACT YOUR NEAREST AUTHORISED SERVICE CENTRE.



NEVER PLACE FLAMMABLE OBJECTS IN THE OVEN: IF IT SHOULD ACCIDENTALLY BE SWITCHED ON, THIS MIGHT CAUSE A FIRE.



**THE APPLIANCE BECOMES VERY HOT DURING USE.** TAKE CARE NEVER TO TOUCH THE HEATING ELEMENTS INSIDE THE OVEN.



**THE APPLIANCE IS INTENDED FOR USE BY ADULTS.** NEVER ALLOW CHILDREN TO PLAY WITH IT. WHEN THE GRILL IS IN OPERATION, ACCESSIBLE PARTS MAY BECOME VERY HOT: **KEEP CHILDREN AT A SAFE DISTANCE**



AFTER EACH USE, ALWAYS CHECK THAT THE CONTROL KNOBS ARE TURNED TO THE **0** (OFF) POSITION.



BEFORE THE APPLIANCE IS PUT INTO OPERATION, ALL THE LABELS AND PROTECTIVE FILMS APPLIED INSIDE OR OUTSIDE MUST BE REMOVED.

### 4. INTENDED USE

THE APPLIANCE IS BUILT TO PROVIDE THE FOLLOWING FUNCTION: **COOKING AND HEATING FOODS**; ALL OTHER USES ARE TO BE CONSIDERED IMPROPER.



*The manufacturer declines all responsibility for injury or damage caused by failure to comply with the above regulations or deriving from tampering with even just one part of the appliance and the use of non-original spare parts.*



## 5. GETTING TO KNOW YOUR COOKER

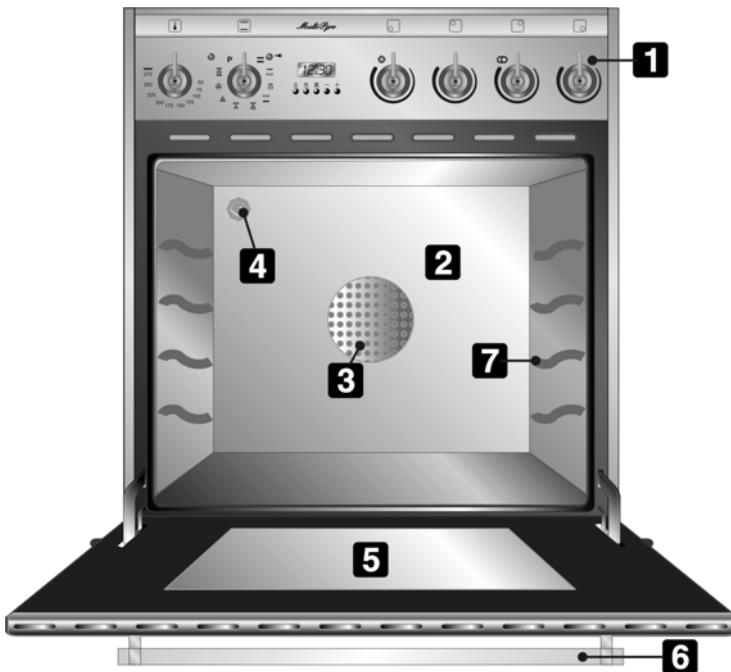

- 1** CONTROL PANEL
- 2** OVEN COMPARTMENT
- 3** OVEN FAN
- 4** OVEN LIGHT
- 5** OVEN DOOR
- 6** OVEN DOOR HANDLE
- 7** SHELF AND TRAY RUNNERS

## 6. BEFORE INSTALLATION



Never leave packaging residues unattended in the home. Separate the various waste packaging materials by type and consign them to the nearest separate disposal centre.



The inside of the appliance should be cleaned to remove all manufacturing residues. For further information about cleaning, see "12. CLEANING AND MAINTENANCE".



When the oven and grill are used for the first time, they should be heated to the maximum temperature for long enough to burn off any oily residues left by the manufacturing process, which might contaminate foods with unpleasant smells.

After an interruption in the electricity supply, the display flashes at regular intervals, showing **0:00**. For setting instructions, see point "11. ELECTRONIC PROGRAMMER".



## 7. DESCRIPTION OF FRONT PANEL CONTROLS

All the control and monitoring devices are clearly in view on the front panel. The table below provides the key to the symbols used.



OVEN THERMOSTAT



FRONT LEFT-HAND COOKING ZONE



FUNCTION SELECTOR KNOB



REAR LEFT-HAND COOKING ZONE



REAR RIGHT-HAND COOKING ZONE



FRONT RIGHT-HAND COOKING ZONE



Before using the oven, check that the display is showing the symbol (see point "11. ELECTRONIC PROGRAMMER").

### HOB CONTROL KNOBS

#### Standard heating

The ring beside each knob identifies the corresponding cooking zone. To switch it on, turn the knob to the required setting. Setting is on a gradual scale, so all the intermediate positions between the numbers can be used.

To switch off the zone, return the knob to the setting



#### Dual heating

The ring beside each knob identifies the corresponding cooking zone. To heat the inner cooking zone, turn the knob to the required setting. To heat both cooking zones (inner and outer) simultaneously, turn the knob to / and then release it. The knob will return to the maximum setting. To regulate the heating level, turn the knob anti-clockwise to the setting required. To return to heating of the inner cooking zone, turn the knob to and then turn it to the required setting. To switch off the zone, return the knob to .



### THERMOSTAT KNOB

The cooking temperature is selected by turning the knob clockwise to the required setting, between 50° and 275°C.

The light comes on to indicate that the oven is heating up. This light goes out when the set temperature is reached. Flashes at regular intervals to indicate that the temperature inside the oven is being kept constantly at the set level.















## Instructions for the User

GB-IE

### FUNCTION SELECTOR KNOB

The electric oven's various functions are suitable for different cooking modes. After selecting the function required, set the cooking temperature using the thermostat knob.



	TOP AND BOTTOM HEATING ELEMENTS		GRILL ELEMENT + FAN
	GRILL		BOTTOM HEATING ELEMENT + FAN
	GRILL ELEMENT + ROTISSERIE		FAN HEATING ELEMENT
	BOTTOM HEATING ELEMENT		TOP + BOTTOM HEATING ELEMENTS + FAN HEATING ELEMENT
	TOP AND BOTTOM HEATING ELEMENTS + FAN FUNCTION		AUTOMATIC CLEANING CYCLE (PYROLYSIS)

### DOOR INTERLOCK WARNING LIGHT

During the automatic (Pyrolysis) oven cleaning cycle, this light comes on to indicate that the oven door interlock has been activated.







## 8. USING THE HOB

### 8.1 Cooking zones

The appliance is equipped with 4 cooking zones having different diameters and powers. Their positions are clearly marked by rings and heating only occurs inside the diameters marked on the ceramic hob. The 4 cooking zones are of HIGH-LIGHT type and start to heat up a few seconds after they are switched on. The heat level can be adjusted from the minimum to the maximum settings using the knobs on the front panel.

The cooking zones marked with two concentric circles  and a circle + a fish zone  are dual heating type: cooking is possible on the smaller diameter only, or on both diameters.

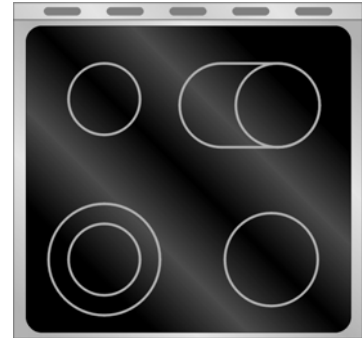

The 4 lights between the cooking zones come on when one or more cooking zones exceed 60° C and go out when the temperature drops below about 60°C.



*When the hob is used for the first time, it should be heated to the maximum temperature for long enough to burn off any oily residues left by the manufacturing process, which might contaminate foods with unpleasant smells.*

For efficient operation without wasting energy, only pans suitable for cooking on electric appliances must be used:

- Pan bottoms must be very thick and perfectly flat, and they and the hob must be clean and dry.
- Never use cast iron or rough-bottomed pans since they might scratch the cooking surface.
- The diameter of the pan bottom must be the same as the diameter of the ring on the cooking zone; otherwise, energy will be wasted.

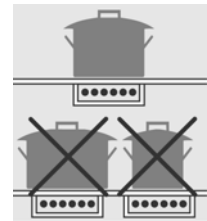

*Take care not to spill sugar or sugar mixtures onto the hob when hot. Do not place materials or substances which might melt (plastic or aluminium foil) on the hob. If this should occur, to prevent damage to the hob's surface, switch it off immediately and remove the melted material with the scraper provided while the hob is still warm. **If the ceramic hob is not cleaned immediately, residues may form which cannot be removed once the hob has cooled.***



**Important.**

*Keep a close eye on children because they are unlikely to see the residual heat warning lights. The cooking zones are still hot for some time after use, even if they are switched off. Make sure that children never touch the hob.*







## 9. USING THE OVEN



Before using the oven, check that the display is showing the  symbol.



The appliance becomes very hot during use. Oven gloves should always be worn.

### 9.1 Precautions and General Advice

When the oven and grill are used for the first time, they should be heated to the maximum temperature for long enough to burn off any oily residues left by the manufacturing process, which might contaminate foods with unpleasant smells. After an interruption in the electricity supply, the display flashes at regular intervals, showing . For setting instructions, see point "11. ELECTRONIC PROGRAMMER".



Oven accessories which may come into contact with foods are made from materials compliant with the relevant regulations.



During cooking, do not cover the bottom of the oven with aluminium foil, and do not place pans or trays on it; this may damage the enamel coating. If you wish to use greaseproof paper, position it so that it does not interfere with the hot air circulation inside the oven.



To avoid unpleasant contact with any steam inside the oven, open the door in two stages: hold it half-open (about 5 cm) for 4-5 seconds, then open it completely. If you have to carry out any procedures on foods, leave the door open for as short a time as possible to prevent a drop in the oven temperature which will impair the cooking results. When the door is opened the oven's internal fan cuts out automatically; it starts up again when the door is closed.



### 9.2 Cooling fan system

A cooling system comes into operation a few minutes after the oven is switched on. Operation of the fan generates a normal air flow which comes out above the door and may continue for a short time even after the oven is turned off.

### 9.3 Using the electric grill

For short cooking procedures, such as final browning of cooked meat, select the static grill function  and turn the thermostat knob to the maximum temperature setting. The fan grill function (on some models only) allows real cooking processes to be carried out, thanks to the forced fan system that ensures the heat penetrates inside the food. For this type of cooking operation, select the fan grill function  and use the function selector knob to set the ideal cooking temperature (in all cases no more than 200°C).

#### 9.3.1 Operation of the grill + rotisserie

The grill function allows cooking in combination with the rotisserie. Fit the spit rod into the rotisserie bushing, select the grill function  and turn the thermostat knob to the temperature required (never exceed 200°C).

Prepare the rotisserie rod with the food and tighten the screws **A** of the prongs. Fit the supporting frame **B** onto the third runners from the bottom. Remove the handle **D** and position the rotisserie rod so that the pulley **E** can turn on the frame **B**. Push the frame **B** fully into the oven until the tip of the rotisserie rod enters the hole **C** on the rear wall of the oven. Place a tray **F** on the bottom runners and pour a little water into it to prevent smoke from forming.

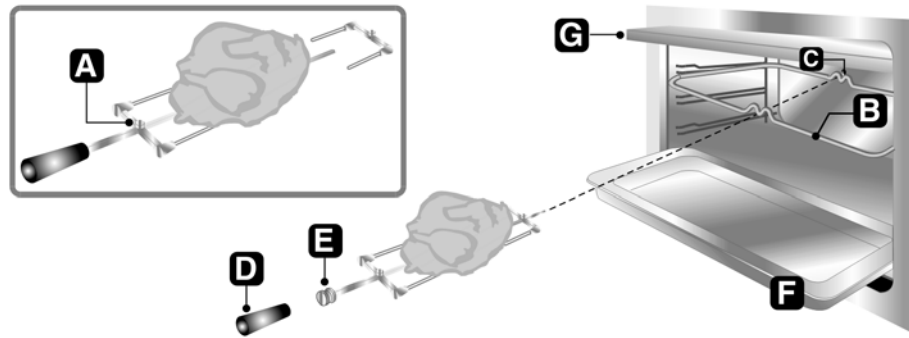

### 9.4 Using the grill



When the oven has come on (the red light comes on to confirm this), leave it to heat up for 5 minutes before placing foods inside.

Seasonings must be added to foods before cooking. Foods should also be coated with oil or melted butter before cooking. Use the oven tray to collect juice.

The foods for cooking must be placed on the oven shelf, which is then placed on one of the runners fitted in the various types of ovens, following the guidelines below:

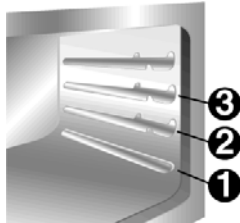

FOODS	RUNNER HEIGHT
Flat, thin pieces of meat	3
Rolled roasts	2 - 3
Poultry	2 - 3

### 9.5 Attention



- Grilling processes must never last more than 60 minutes.
- In models with electric oven, the oven door must be closed during grill and grill + rotisserie cooking operations.
- To prevent hazardous overheating, the appliance's glass lid must always be raised when using the oven or grill.
- Accessible parts may be very hot during and after use of the grill; keep children well away from the appliance.
- During rotisserie cooking operations, one of the pans supplied with the cooker should be placed on the bottom of the oven, on the bottom runners, to collect any grease and fat produced.
- During cooking, do not cover the bottom of the oven with aluminium foil, and do not place pans or trays on it; this may damage the enamel coating. If you wish to use greaseproof paper, position it so that it does not interfere with the hot air circulation inside the oven.
- When using the oven, remove all unused pans and shelves from its interior.

### 9.6 Storage compartment

The storage compartment is in the bottom of the cooker, underneath the oven. To open it, pull on the top of the door.

Never use it to store flammable materials such as rags, paper, etc.; it is intended to take the appliance's metal accessories only.



Never open the storage compartment when the oven is on and still hot. The temperatures inside it may be very high.



### 10. ACCESSORIES AVAILABLE

The oven is fitted with **4 runners** for placing trays and shelves at different heights.

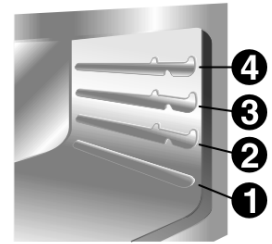

**Oven shelf:** for cooking food on plates, small cakes or roasts or foods requiring light grilling.

**Tray grid:** for placing on top of a tray for cooking foods which may drip.

**Oven tray:** useful for collecting fat from foods placed on the grid above.

**Baking tray:** useful for cooking cakes, pizza and confectionery.

**Rotisserie rod:** useful for cooking chicken, sausages and all foods which require uniform cooking over their entire surface.

**Rotisserie frame:** for fitting onto the oven runners before the rotisserie rod is used.

**Chromium-plated gripper:** useful for removing hot shelves and trays.



*Not all accessories are provided on some models.*

#### **Optional accessories**





*Original optional accessories can be ordered through our Authorised Service Centres.*







## 11. ELECTRONIC PROGRAMMER



### LIST OF FUNCTIONS

-  TIMER BUTTON
-  END OF COOKING BUTTON
-  COOKING DURATION BUTTON
-  VALUE DECREASE BUTTON
-  VALUE INCREASE BUTTON

### 11.1 Setting the time





When the oven is used for the first time, or after an interruption in the electricity supply, the display flashes at regular intervals, showing **0:00**. Press the  and  keys together, and at the same time press the  or  keys: this will increase or decrease the setting by one minute for each pressure.

*Before each programmer setting, switch on the function and set the temperature required.*





### 11.2 Semiautomatic cooking



This function only switches the oven off automatically at the end of the cooking time.



Press the  key and the display will light up showing the figures **0:00**; keep it pressed, and at the same time use the value modification keys  or  to set the cooking duration. When the  key is released, the count of the programmed cooking duration will start and the display will show the current time together with the symbols **A** and .



### 11.3 Automatic cooking

This function switches the oven on and off in fully automatic mode.

Press the  key and the display will light up showing the figures **0:00**; keep it pressed, and at the same time use the value modification keys  or  to set the cooking duration.

Press the  key and the display will show the sum of the current time plus the cooking duration: keep it pressed, and at the same time use the value modification keys  or  to adjust the end of cooking time.

When the  key is released, the programmed count will start and the display will show the current time together with the symbols **A** and .

*After making the setting, press the  key to view the cooking time remaining; press the  key to view the cooking end time. The logic prevents the setting of incompatible values (e.g. the timer will not accept a cooking end time with a duration which is too long for this value).*







### 11.4 End of cooking

At the end of the cooking time the oven will switch off automatically and simultaneously a buzzer will start to sound in on-off mode.

After the buzzer is stopped, the display will return to showing the current time together with the  symbol, indicating that the oven is again ready for use in manual mode.



### 11.5 Timer

The programmer can also be used as an ordinary timer. Press the  key and the display will show the figures ; keep it pressed and simultaneously press the value modification keys  or . When the  key is released the programmed count will start and the display will show the current time and the symbol.





*After making the setting, to display the time remaining press the  key.  
In timer mode, the system will not cut out operation of the oven at the end of the set time.*

### 11.6 Adjusting the buzzer volume



The buzzer has 3 different volume settings.

To change the setting, press the  key at the end of the timer function with the buzzer in operation.



### 11.7 Stopping the buzzer

The buzzer stops automatically after seven minutes. It can be stopped in manual mode by pressing the  and  keys together. To switch off the appliance, return the knobs to the 0 setting.

### 11.8 Deleting the data set

With the program set, keep the key of the function for deletion pressed, while at the same time setting the value  by pressing the value modification keys  or . The programmer will interpret deletion of the duration as the end of cooking.

### 11.9 Modifying the data set

The cooking data set can be modified at any moment by keeping the key of the function for modification pressed and at the same time pressing the value modification keys  or .



## 12. CLEANING AND MAINTENANCE

*Before carrying out any operations, disconnect the appliance from the electricity supply.*



*Never use a jet of steam for cleaning the appliance.*



### 12.1 Cleaning stainless steel

*To keep stainless steel in good condition, it must be cleaned regularly, after each use of the cooker, after allowing it to cool.*



### 12.2 Routine daily cleaning

When cleaning and caring for stainless steel surfaces, always use **only** specific products which do not contain abrasives or chlorine-based acids.

**Instructions for use:** pour the product onto a damp cloth and wipe over the surface, then rinse thoroughly and dry with a soft cloth or chamois leather.

### 12.3 Food stains or spills

Never use metal scouring pads or sharp scrapers; they will damage surfaces.

Use ordinary non-abrasive products for steel, with the aid of wooden or plastic utensils if necessary.

Rinse thoroughly and dry with a soft cloth or chamois leather.

Do not allow spills of foods with high sugar content (e.g. jam) to dry inside the oven. If they dry for too long, they might damage the enamel coating of the inside of the oven.



### 12.4 Cleaning the ceramic hob

*The ceramic hob must be cleaned regularly, preferably after each use, when the residual heat warning lights have gone out.*



Any marks left by the use of pans with aluminium bottoms can be wiped off with a cloth dipped in vinegar.

If burnt residues are left after cooking, remove them with the scraper provided, rinse with water and dry thoroughly with a clean cloth. Regular use of the scraper considerably reduces the use of chemicals for daily cleaning of the hob. In any case, abrasive or corrosive cleaners (e.g. powder products, oven-cleaner sprays, stain removers and metal scouring pads) must never be used.

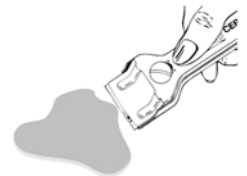



## 12.5 Cleaning the oven



To keep the oven in good condition, it must be cleaned regularly, after allowing it to cool down. Remove all removable parts.

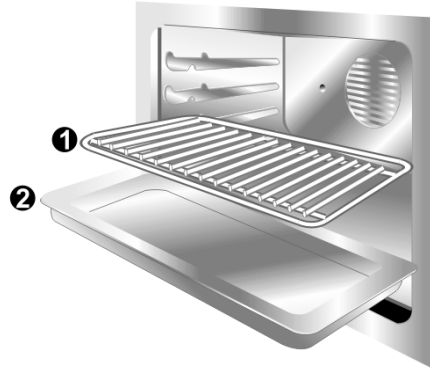

- Clean the oven shelves with hot water and non-abrasive detergents, rinse and dry.
- The round cover must be left in place during cleaning operations and must be dried quickly to ensure that no liquids can leak underneath it. If this should occur, remove the cover, **cut off the power supply to the appliance** and dry the area underneath.
- Wash the pizza plate separately with a non-abrasive metal pad dipped in lemon or vinegar: **never wash in the dishwasher or with an ordinary detergent.**

## 12.6 Cleaning the door glazing

The glass in the door should always be kept thoroughly clean. Use absorbent kitchen roll; remove stubborn dirt with a damp sponge and ordinary detergent.



When cleaning, dry the appliance thoroughly to prevent water or detergent drips from interfering with its operation or creating unsightly marks.

## 12.7 Pyrolysis: automatic oven cleaning



Pyrolysis is an automatic high-temperature cleaning procedure which causes dirt to dissolve.



Before starting the automatic cleaning cycle, make sure that the oven does not contain any foods or large spills from previous cooking operations inside.



A door interlock device means that the door cannot be opened during the procedure. If the oven is installed underneath a hob, make sure that the burners or electric plates remain off during the automatic cleaning cycle.

## 12.8 Before starting the automatic cleaning cycle



Pyrolysis may be carried out at any time of the day or night (if you wish to benefit from the lower cost of electricity overnight).

- only the baking tray, the oven tray and the roof liner may be left inside the oven since they will withstand the high temperatures of the pyrolysis process; all the other accessories must be removed from inside the oven.
- remove the most obvious dirt (cleaning it by Pyrolysis would take too long);
- make sure that the oven door is firmly closed;
- when setting the cleaning cycle duration, refer to the chart below:

	LIGHT DIRT	MEDIUM DIRT	HEAVY DIRT
CLEANING DURATION:	90 MIN.	120 MIN.	180 MIN.





During the first automatic cleaning cycle unpleasant smells may occur due to the normal evaporation of oily manufacturing substances. This is an absolutely normal phenomenon which disappears after the first cleaning cycle.



During the automatic cleaning cycle the fans make more noise because they are running at higher speed. This is an absolutely normal function, intended to provide more effective heat dispersal. At the end of the pyrolysis process the fans continue to run automatically for long enough to prevent overheating of the sides of the cabinet and the front of the oven.

### 12.9 Setting the automatic cleaning cycle

Turn the function selector knob to the **P** symbol to start the pyrolysis cycle. The orange thermostat light comes on, followed a few minutes later by the red "door interlock" light to indicate that the appliance's door has been locked because of the high temperature inside the oven. As soon as the function selector knob is turned to **P**, the display shows **P1:30** to indicate that the pyrolysis cycle will start immediately and will last an hour and a half. The duration of the pyrolysis cycle can be increased up to a maximum of 3 hours. To do this, after the pyrolysis cycle starts press the  key followed within a few seconds by the value modification keys **-** or **+**. A few seconds after the last key is pressed, the display will show the letter **P** followed by the pyrolysis duration just set, and the letter **A** will stop flashing. After starting the pyrolysis procedure, and modifying its duration as just described if required, the cleaning cycle end time can also be programmed.

Press button . The letter **A** will flash on the display, which will also show the sum of the current time plus the duration of the pyrolysis cycle (e.g.: Current time: 12.10 - Programmed duration: 2.00 - Figure shown: 14.10). At this point, the value modification keys **-** or **+** can be used to set the cleaning cycle end time. A few seconds after the last key is pressed, the display will show the current time and the orange light will go out; it will come back on at the preset time.



**Warning:** do not leave anything in the oven during the pyrolysis cycle. Keep children at a safe distance and take care, especially if the cycle is set to start with a delay.



Use of the ceramic hob is not permitted during the pyrolysis cycle.





### 13. EXTRAORDINARY MAINTENANCE

Occasionally, the oven will require minor servicing procedures or the replacement of parts subject to wear and tear, such as gaskets, light bulbs, etc. The specific operations for each procedure of this kind are provided below.



*Before carrying out any operations, disconnect the appliance from the electricity supply.*

#### 13.1 Changing the light bulb

Remove the protective cover **A** by unscrewing it clockwise; replace the bulb **B** with another of the same type (25 W). Replace the protective cover **A**.

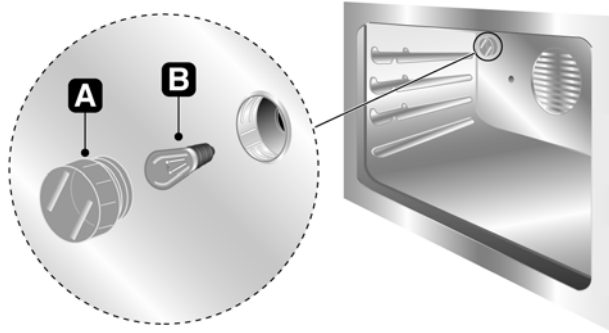

*Use only light bulbs approved for ovens (T 300°C).*

#### 13.2 Removing the door

Fully open the door and turn the hinges **A** to the limit with the aid of a thin-tip screwdriver.

Take hold of the two sides of the door with both hands near to the hinges, close it to an angle of about 45° and remove it.

To reassemble the door, fit the guide **B** into the oven surround, replace the hinges **A** in the position shown here and press them sharply down with a screwdriver or a similar tool until you hear them snap into place.

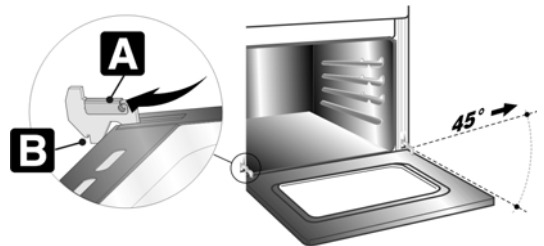

#### 13.3 Removing the gasket

If the oven door gasket should require replacement, contact your nearest authorised service centre.



## 14. INSTALLING THE APPLIANCE



The appliance must be installed by a qualified engineer in compliance with the relevant regulations. It may be installed against walls one of which is higher than the worktop surface, as shown in the installation class drawings A and B. Wall units or extractor hoods installed above the appliance's worktop must be at least 75 cm above it.

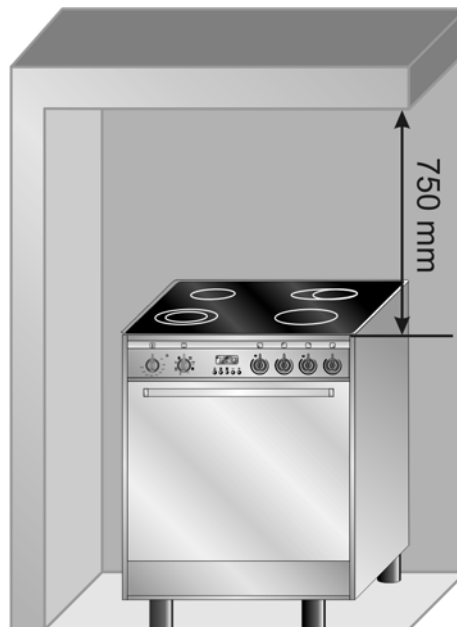
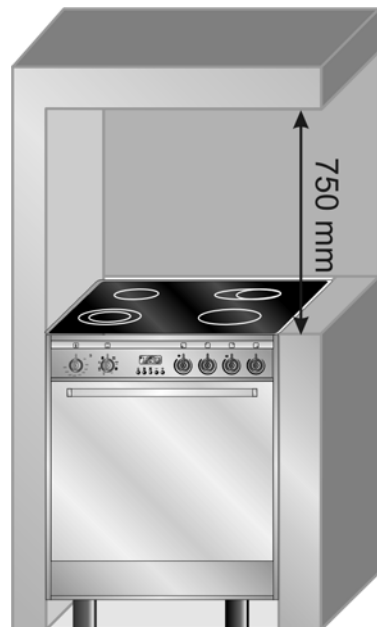

### 14.1 Electrical connection



Check that the voltage and size of the power supply line are as specified on the nameplate inside the storage compartment. **This nameplate must never be removed.**



If a permanent connection to the electrical mains is used, the appliance's power supply line must be fitted with an omnipolar breaking device with contact breaking gap of at least **3 mm** located in an easily accessible position close to the appliance itself.



The mains connection may be permanent or by means of a plug and socket. If a plug and socket connection is used, suitable cable compliant with the relevant standards must be used. For each type of connection, the appliance must always be connected to earth. Before connecting it, check that the power supply line is properly earthed. The use of adapters is not recommended since they may cause overheating.

The appliance has a terminal board on its rear. Make the electrical connection in accordance with the wiring diagram shown below.

To access the terminal board, remove the guard on the rear.

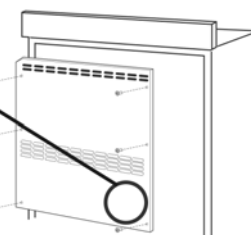



## Instructions for the Installer

GB-IE



**Operation at 380-415V 3N~:** use a H05RR-F / H05RN-F five-wire cable (cable of 5 x 2.5 mm<sup>2</sup>).

**Operation at 380-415V 2N~:** use a H05RR-F four-wire cable (cable of 4 x 4 mm<sup>2</sup>).

**Operation at 220-240 V~:** use a H05RR-F three-wire cable (cable of 3 x 6 mm<sup>2</sup>).

The earth wire (yellow-green) must be at least 20 mm longer than the other wires at the end for connection to the appliance.

**380-415V 3N~** 2.5 mm<sup>2</sup>

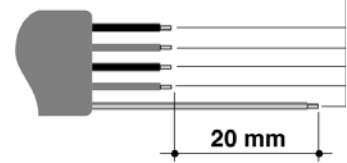

**380-415V 2N~** 4 mm<sup>2</sup>

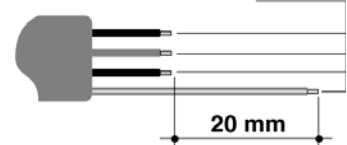

**220-240V~** 6 mm<sup>2</sup>

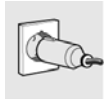
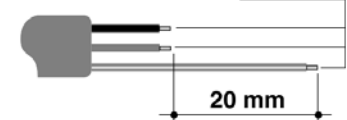

The power supply cable must be fitted with a suitable five-pin plug (see technical data plate) or, for appliances operating on **220-240 V**, a three-pin plug. The power supply plug and wall socket must be of the same type and compliant with the relevant regulations. Check that the appliance is earthed appropriately. Before putting the appliance into operation, check that the power supply line is properly earthed. The use of adapters or junctions is not recommended.



**THE MANUFACTURER DECLINES ALL RESPONSIBILITY FOR INJURY OR DAMAGE CAUSED BY FAILURE TO COMPLY WITH THE ABOVE REGULATIONS**



### 14.2 Fitting the rear splash-back

- Unscrew the nuts **B**.
- Place the splash-back on the hob, aligning the rods **C** with the holes **D**.
- Fix the splash-back to the hob by tightening the screws **A**.

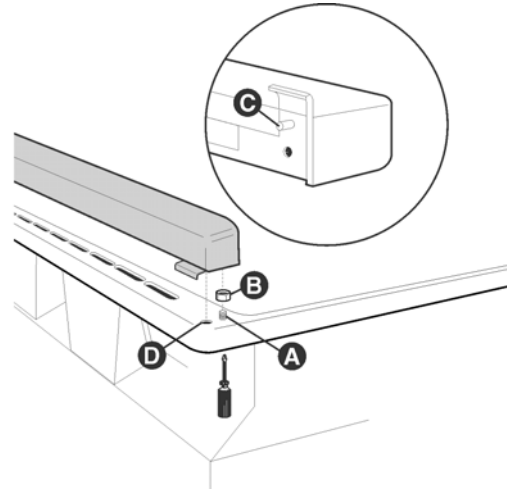

### 14.3 Positioning and levelling the appliance (depending on model)

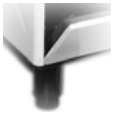

After making the electrical and gas connections, level the the appliance on the ground by means of its four adjustable feet. For good cooking results, the appliance must be properly levelled. Depending on the model you have purchased, the foot height adjustment range may vary from 70 to 95 mm and from 110 to 160 mm. These heights refer to the distance between the highest point of the foot (fixed part) and the lowest point (movable part which rests on the floor).