

Pioneer

**AUDIO/VIDEO MULTICHANNEL
AMPLIFIER**

VSA-E03

Operating Instructions

Thank you for buying this Pioneer product. Please read through these operating instructions so you will know how to operate your model properly. After you have finished reading the instructions, put them away in a safe place for future reference.

In some countries or regions, the shape of the power plug and power outlet may sometimes differ from that shown in the explanatory drawings. However the method of connecting and operating the unit is the same.

WARNING: TO PREVENT FIRE OR SHOCK HAZARD, DO NOT EXPOSE THIS APPLIANCE TO RAIN OR MOISTURE.

This product complies with the Low Voltage Directive (73/23/EEC), EMC Directives (89/336/EEC, 92/31/EEC) and CE Marking Directive (93/68/EEC).

THE POWER SWITCH IS SECONDARY CONNECTED AND THEREFORE DOES NOT SEPARATE THE UNIT FROM MAINS POWER IN THE STANDBY POSITION.

VENTILATION

- When installing this unit, make sure to leave space around the unit for ventilation to improve heat radiation (at least 60 cm at top, 10 cm at rear, and 30 cm at each side). If not enough space is provided between the unit and walls or other equipment, heat will build up inside, interfering with performance or causing malfunctions.
- Do not place on a thick carpet, bed, sofa or fabric having a thick pile. Do not cover with fabric or other covering. Anything that blocks ventilation will cause internal temperature to rise, which may lead to breakdown or fire hazard.

IMPORTANT



The lightning flash with arrowhead symbol, within an equilateral triangle, is intended to alert the user to the presence of uninsulated "dangerous voltage" within the product's enclosure that may be of sufficient magnitude to constitute a risk of electric shock to persons.



CAUTION:
TO PREVENT THE RISK OF ELECTRIC SHOCK, DO NOT REMOVE COVER (OR BACK). NO USER-SERVICEABLE PARTS INSIDE. REFER SERVICING TO QUALIFIED SERVICE PERSONNEL.



The exclamation point within an equilateral triangle is intended to alert the user to the presence of important operating and maintenance (servicing) instructions in the literature accompanying the appliance.

Power cord CAUTION!

Handle the power cord by the plug. Do not pull out the plug by tugging the cord and never touch the power cord when your hands are wet as this could cause a short circuit or electric shock. Do not place the unit, a piece of furniture, etc., on the power cord, or pinch the cord. Never make a knot in the cord or tie it with other cords. The power cords should be routed such that they are not likely to be stepped on. A damaged power cord can cause a fire or give you an electrical shock. Check the power cord once in a while. When you find it damaged, ask your nearest PIONEER authorized service center or your dealer for a replacement.

Maintenance of External Surfaces

- Use a polishing cloth or dry cloth to wipe off dust and dirt.
- When the surfaces are dirty, wipe with a soft cloth dipped in some neutral cleanser diluted five or six times with water, and wrung out well, and then wipe again with a dry cloth. Do not use furniture wax or cleaners.
- Never use thinners, benzine, insecticide sprays or other chemicals on or near this unit, since these will corrode the surfaces.

IMPORTANT

FOR USE IN THE UNITED KINGDOM

The wires in this mains lead are coloured in accordance with the following code :

Blue :Neutral
Brown :live

If the plug provided is unsuitable for your socket outlets, the plug must be cut off and a suitable plug fitted.

The cut-off plug should be disposed of and must not be inserted into any 13 amp socket as this can result in electric shock. The plug or adaptor or the distribution panel should be provided with 5 amp fuse. As the colours of the wires in the mains lead of this appliance may not correspond with coloured markings identifying the terminals in your plug, proceed as follows:

The wire which is coloured blue must be connected to the terminal which is marked with the letter N or coloured black. The wire which is coloured brown must be connected to the terminal which is marked with the letter L or coloured red.

Do not connect either wire to the earth terminal of a three pin plug.

NOTE

After replacing or changing a fuse, the fuse cover in the plug must be replaced with a fuse cover which corresponds to the colour of the insert in the base of the plug or the word that is embossed on the base of the plug, and the appliance must not be used without a fuse cover. If lost, replacement fuse covers can be obtained from your dealer.

Only 5 A fuses approved by B.S.I. or A.S.T.A. to B.S. 1362 should be used.

Introductory Information	5
Checking the Supplied Accessories	5
How to Use This Manual	5
Preparing the Remote Control	5
When Making Cable Connections	6
Connections	7
Audio Components Connections	7
Video Components Connections	8
Digital Connections	9
DVD 5.1 Channel Connection	10
Speakers	11
Preparations	14
Setting Up for Surround Sound	14
Setting Up the Remote Control	20
Clearing the Remote Control Settings	21
Names of Parts and Basic Operations	22
Display	22
Remote Control	23
Front Panel	24
Sound Modes	26
Switching ANALOG/DIGITAL Signal Input	27
Playback	28
Playing Sources with Dolby Digital	29
Selecting a Sound Mode	30
Listening in MIDNIGHT Listening Mode	31
Adjusting bass and treble (tone control)	32
Other Operations	33
Recording from Audio Components	33
Recording from Video Components	34
Remote Controlling Other Components	35
Background Control of Other Components	41
Additional Information	42
Dolby Digital	42
Troubleshooting	43
Preset Code List	44
Specifications	back cover

Features

Dolby Digital and Dolby Pro Logic

No need to worry about program formats! When playing Dolby Digital or Dolby Surround software in the  (Dolby) Surround mode, decoding switches automatically according to the input signal. All you have to do is sit back and enjoy! (When connecting a DVD/LD player or LD player using the AC-3 RF output, a commercially available RF demodulator (RFD-1) is required.)

Manufactured under license from Dolby Laboratories. "Dolby", "AC-3", "Pro Logic", and double-D symbol are trademarks of Dolby Laboratories. Confidential Unpublished Works. © 1992 - 1997 Dolby Laboratories, Inc. All rights reserved.

Various Surround Effects (DSP)

The DSP (Digital Signal Processing) surround mode allows you to transform your living room into six different sonic environments when listening to music or watching movies.

Midnight Listening Mode

When late night hours or other factors require that the volume be kept low, the surround effects may tend to become less than satisfactory. When the midnight listening mode is on, you can enjoy the effects of quality surround sound even at low volumes.

Optical Digital Output

The digital signal input can be directly output to digital recording components such as MD, DAT and CD-R from the optical digital output jack to create digital recordings.

5.1 Channel Input

By connecting components equipped with 5.1 channel output to the DVD 5.1 channel input on this unit, you can enjoy 5.1 channel surround sound. Connections can be made to a DVD player or Multi channel decoder equipped with 5.1 channel analog output jacks.

5 Channels of Independent Amplification

This receiver incorporates 5 independent 60 watt power amplifiers which enable high quality playback of Dolby Digital sound. This construction provides improved linearity and accurate reproduction of each channel for true high fidelity reproduction from even the most demanding Dolby Digital program sources.

Remote Control of Other Components

The supplied remote control can be used to operate a variety of other components simply by recalling the appropriate preset code.

The Energy-saving Design

This unit is designed to use minimal electricity when power is switched OFF (during Standby). Regarding the value of the power consumption in standby mode, refer to "Specifications" on the back cover.

Checking the Supplied Accessories

Please check that you have received all of the following accessories with the amplifier.

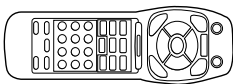

Remote control unit

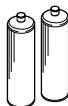

"AA" IEC LR6 batteries x 2

How to Use This Manual

This manual is divided into two main sections :

SET UP

This section explains how to make the necessary connections from the amplifier to your other audio and video components. Amplifier operations described later in this section under the heading "Preparations" enable you to set up and customize your home entertainment center.

OPERATION

This section provides complete information about operation of the amplifier and supplied remote control.

The following marks and symbols are used throughout this manual:



Provides additional information, precautions, and advice.



Indicates a blinking button, indicator, or display.



Indicates a steadily lit button, indicator, or display.

Preparing the Remote Control

Loading the batteries

AA dry cell batteries ((“AA” IEC LR6)×2)

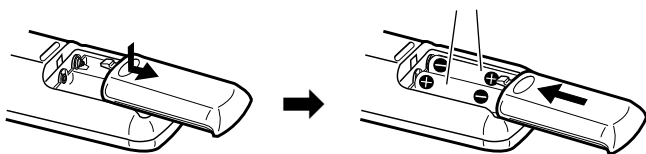

When you notice a decrease in the operating range of the remote control, replace all batteries with new ones.



When changing the batteries, it is recommended that you load new batteries within five minutes of removing the old batteries. If not, the preset codes may be canceled and you will need to set them again (refer to page 20).

CAUTION!

Incorrect use of batteries may result in such hazards as leakage and bursting. Observe the following precautions.

- Never use new and old batteries together.
- Insert the plus and minus sides of the batteries properly according to the marks in the battery case.
- Batteries with the same shape may have different voltages. Do not use different batteries together.

Operating range of remote control unit

Point the remote control toward the remote sensor  on the front panel of this unit to operate. The remote control unit will operate the amplifier for up to a distance of 7 meters within 30° angle on each side of the sensor of the remote sensor as illustrated below.

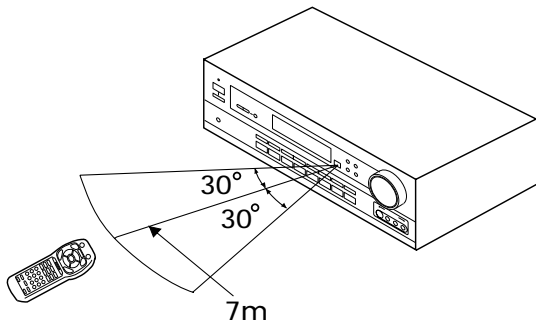

Remote control may not function properly if :

- There are obstacles between the remote control and the remote sensor.
- Direct sunlight or fluorescent light is shining onto the remote sensor.
- The amplifier is located near a device emitting infrared rays.
- Operated simultaneously with another remote control which uses infrared rays.

Operating other PIONEER components

Connecting an optional control cord allows you to operate other PIONEER components simply by pointing the amplifier's remote control at the remote sensor on the front panel of the amplifier. The amplifier then sends the remote control signals to the other devices via the CONTROL OUT terminal.

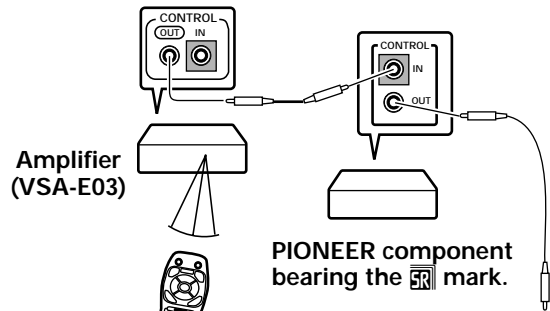

Amplifier (VSA-E03)

PIONEER component bearing the  mark.

Remote Control

To CONTROL IN terminal of another PIONEER component bearing the  mark.



You can also control PIONEER components (and those made by other manufacturers) by pointing the amplifier's remote control directly at the respective component. This type of operation does not require control cords. All you have to do is recall the appropriate preset code (Refer to "Recalling preset codes" on page 20).

When Making Cable Connections

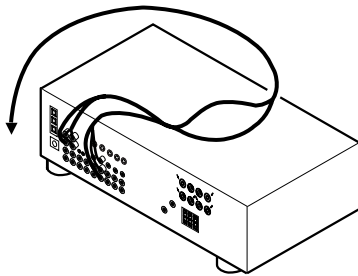

Be careful not to arrange cables in a manner that bends the cables over the top of this unit as shown in the illustration. If the cables are brought over this unit, the magnetic field produced by the transformers in this unit may cause a humming noise to come from the speakers.

Audio Components Connections

Be sure to switch power to standby and remove the power cord from the wall outlet when you make or change connections.

Connect your audio components as shown below. Refer to "Digital Connections" on page 9 when making digital connections from your DVD or LD player.

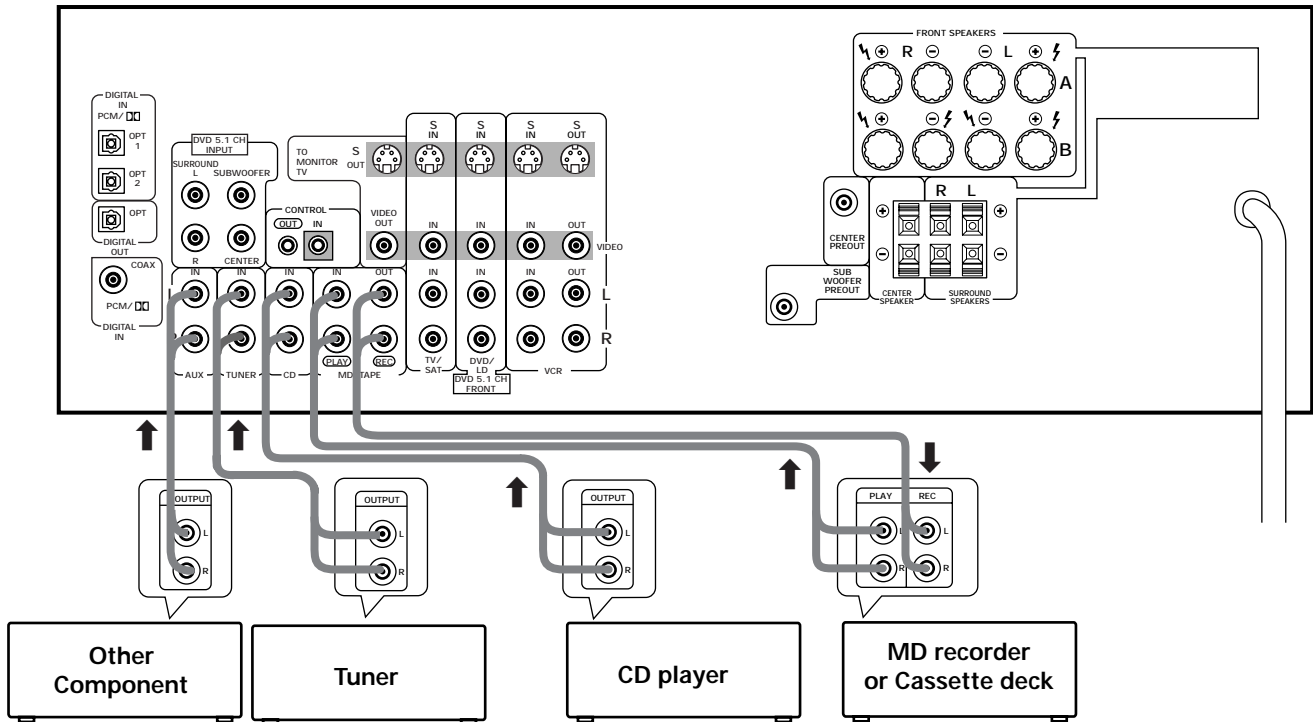

*The arrows indicate the direction of the audio signal.

■ Audio cords

Use audio cords (not supplied) to connect the audio components.

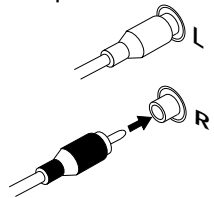

Connect red plugs to R (right) and white plugs to L (left).
Be sure to insert completely.

Cassette deck placement

Depending on where the cassette deck is placed, noise may occur during playback of your cassette deck which is caused by leakage flux from the transformer in the amplifier. If you experience noise, move the cassette deck farther away from the amplifier.

Video Components Connections

- When connecting components, the amplifier should be off and the power cord unplugged.
- Connect your video components as shown below. Also, refer to "Digital Connections" on page 9 when making digital connections from your DVD or LD player.
- If your TV monitor or video camera has an S-Video input, clearer picture reproduction is possible by connecting the amplifier to your TV monitor or video camera via the S-Video jack.

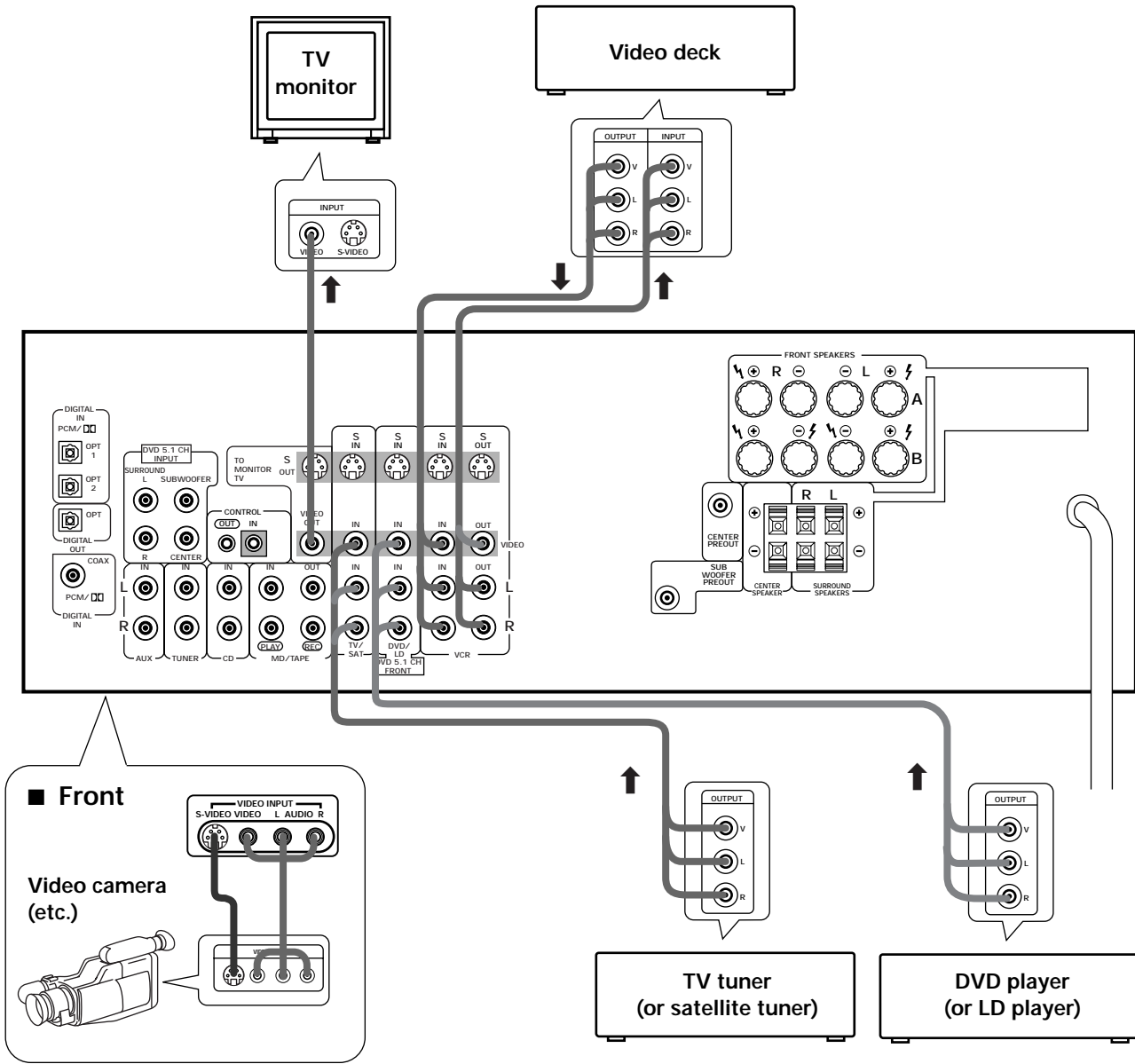

When connecting components equipped with S-video jacks, you can make connections to this unit using S-video cords (not supplied). However, this unit is not designed to convert the format of the video signal. Therefore, the signal from the S IN cannot be output from the VIDEO OUT and similarly the signal from the VIDEO IN cannot be output from the S OUT.

Audio/Video cords

Use audio/video cords (not supplied) to connect the video components and a video cord to connect the TV or monitor.

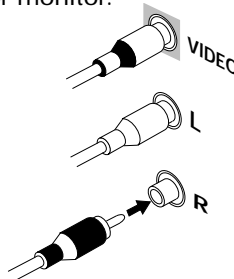

Connect red plugs to R (right), white plugs to L (left), and the yellow plugs to VIDEO. Be sure to insert completely.

Digital Connections

Digital components can be connected as shown below. You can select up to three of the following be assigned to the digital inputs on this unit: VCR, DVD/LD, TV/SAT, CD, MD/TAPE. To assign the digital inputs, refer to "Setting Up for Surround Sound" on page 14.

The digital signal input is output directly to digital recording components from the optical digital output jack.

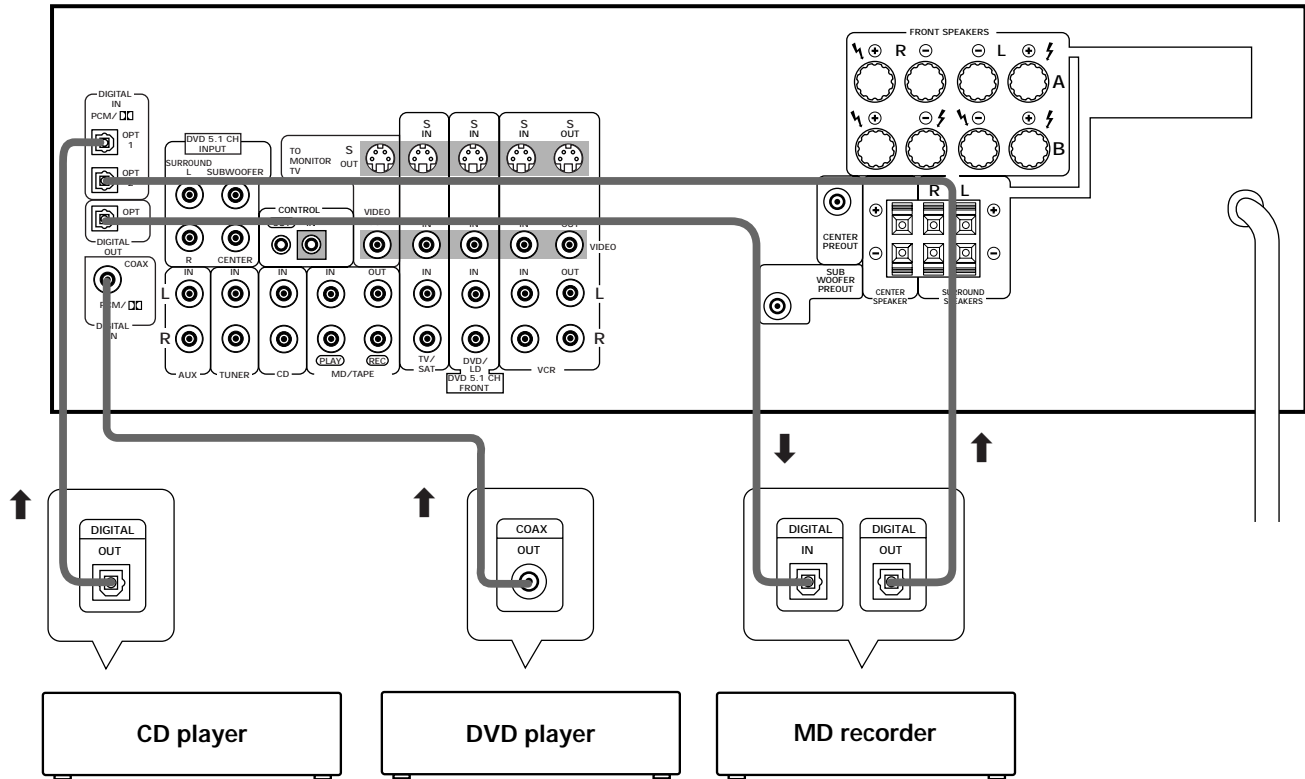

When playing LD recorded in Dolby Digital

When connecting a DVD/LD player or LD player using the AC-3 RF output, a commercially available RF demodulator (RFD-1) is required. The RF demodulator changes the RF signal to a digital signal which is then processed by the amplifier through the digital input jacks. For more details, refer to the instruction manual supplied with the RFD-1.

The factory setting for each of the digital inputs is described below.

- COAX : DVD
- OPT 1 : CD
- OPT 2 : MD

■ Digital audio cords/Fiber-optic cables

Commercially available digital audio coaxial cords (standard video cords can also be used) or fiber-optic cables (not supplied) are used to connect digital components to this amplifier.

When you use optical digital input or output terminals, pull off the caps and insert the plugs. Be sure to insert completely.

Digital audio cord (or standard video cord)

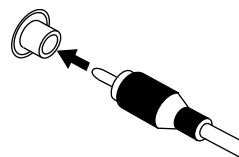

Fiber-Optic cable

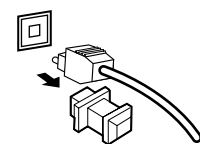

DVD 5.1 Channel Connection

DVD and LD discs are often compatible with both 2 channel and 5.1 channel audio output formats. Refer to page 31 for more information on how to switch between the two input methods.

Connections can be made from a DVD player, or Multi channel decoder equipped with 5.1 analog outputs to the 5.1 analog inputs on this unit.

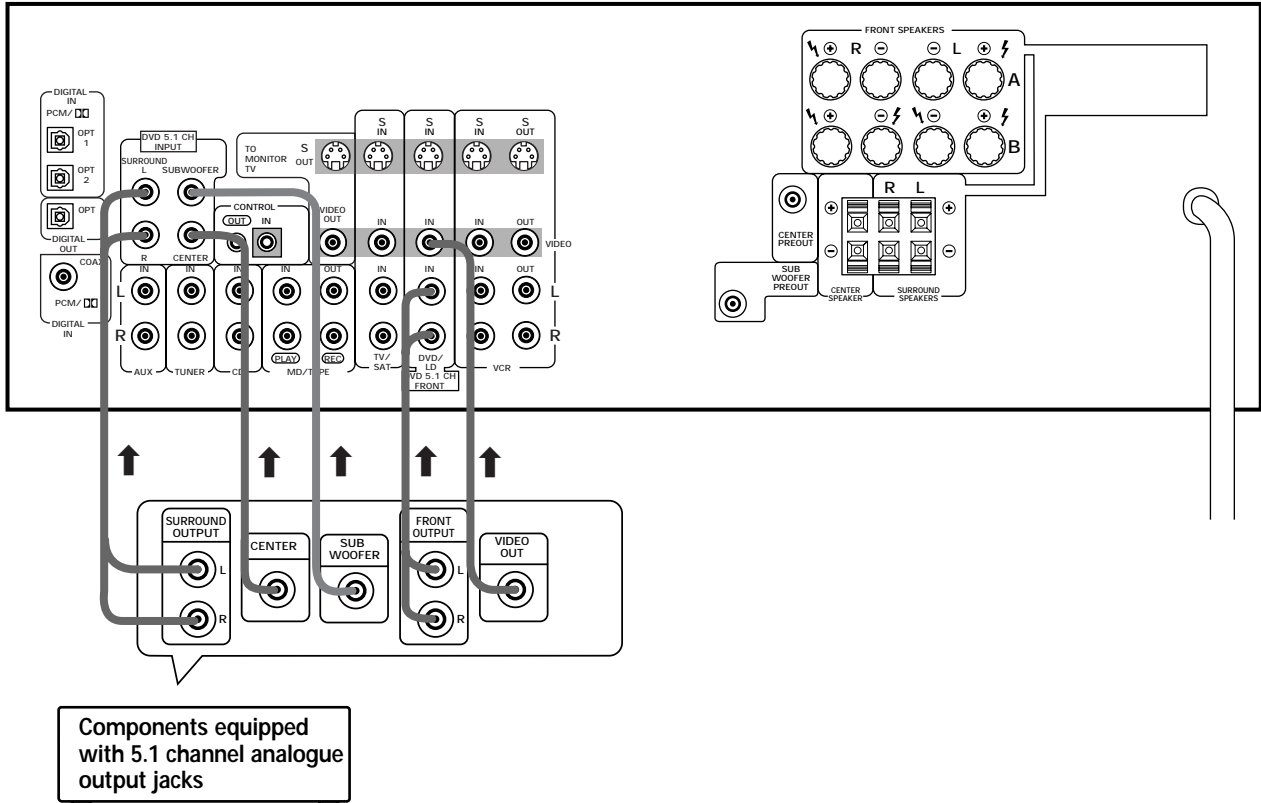

The 5.1 channel input can only be used when DVD/LD is selected.

Speakers

- Use speakers with a nominal impedance of 8 Ω to 16 Ω.
- The front speaker B terminal is only used in stereo mode (Not available during DVD 5.1 channel, DSP mode, or Dolby Surround mode).
- When you use the speaker on your TV as a center speaker, please connect the CENTER PREOUT jack on this unit to the audio input jack on your TV. In this case, the center speaker shown below is unnecessary. Refer to the instruction manual supplied with the TV or monitor you are connecting to for more information.
- You can set the configuration of your speaker system, whether the sizes of the speakers are large or small, and whether or not you have a sub woofer connected. (Refer to pages 14 to 16)
- No sound is output from the front speakers if both A and B speaker systems are selected, but only one pair of speakers is connected to the FRONT SPEAKERS terminals. To select the speaker system, refer to page 24.

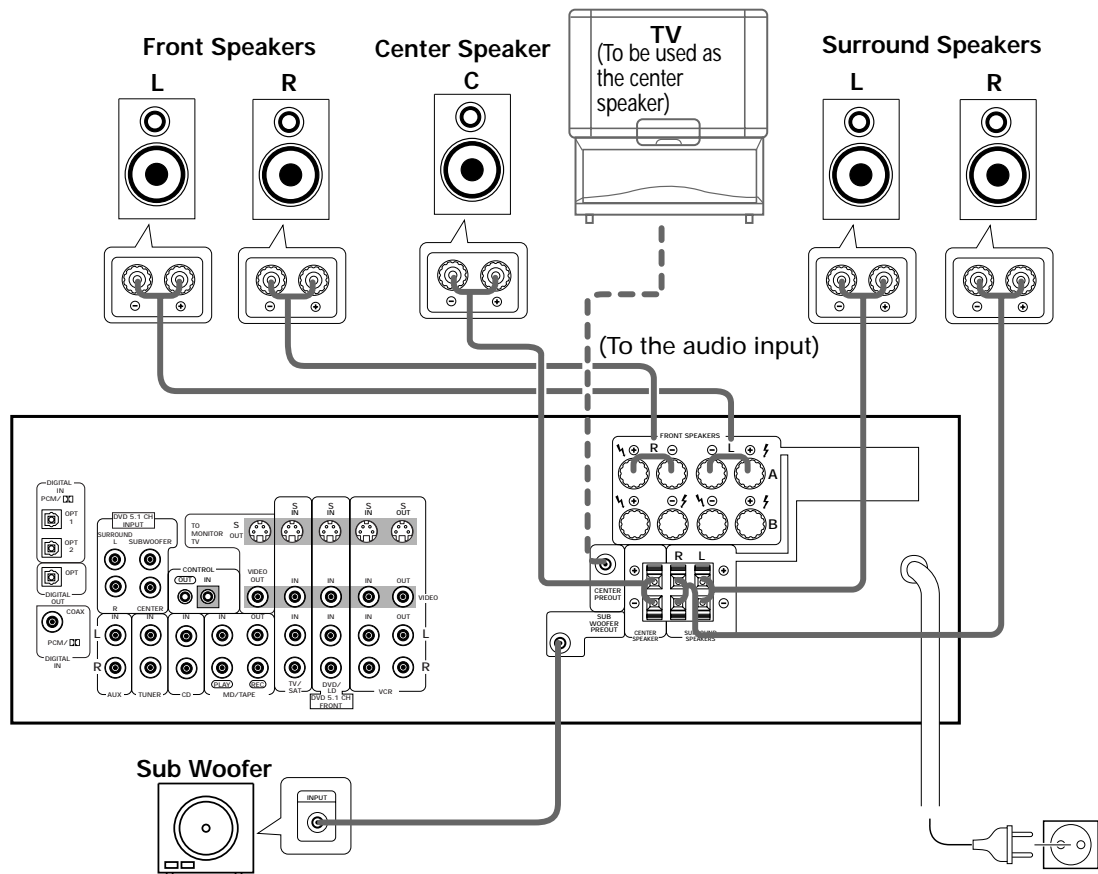

Amplified Sub Woofer

Connection methods that differ from the example shown in this manual may be available. For more details, refer to the instruction manual supplied with the sub woofer.

Be sure to complete all other connections before connecting this unit to the AC power source.

Speaker terminals

Twist exposed wire strands together.

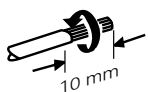

Push tab to the open position, and insert the wire. Then, close tab firmly to secure the wire in place.

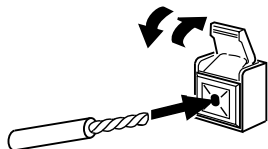

Turn counter-clockwise to loosen, and insert the wire. Then turn clockwise to tighten.



Connecting additional amplifiers

To use separate amplifiers to power your center speaker, make the connections shown below.



Do not make simultaneous connections to both the CENTER PREOUT jack and the CENTER SPEAKER terminals. (i.e. Do not connect a separate power amplifier to the CENTER PREOUT jack if you have already connected a center speaker to the CENTER SPEAKER terminal.)

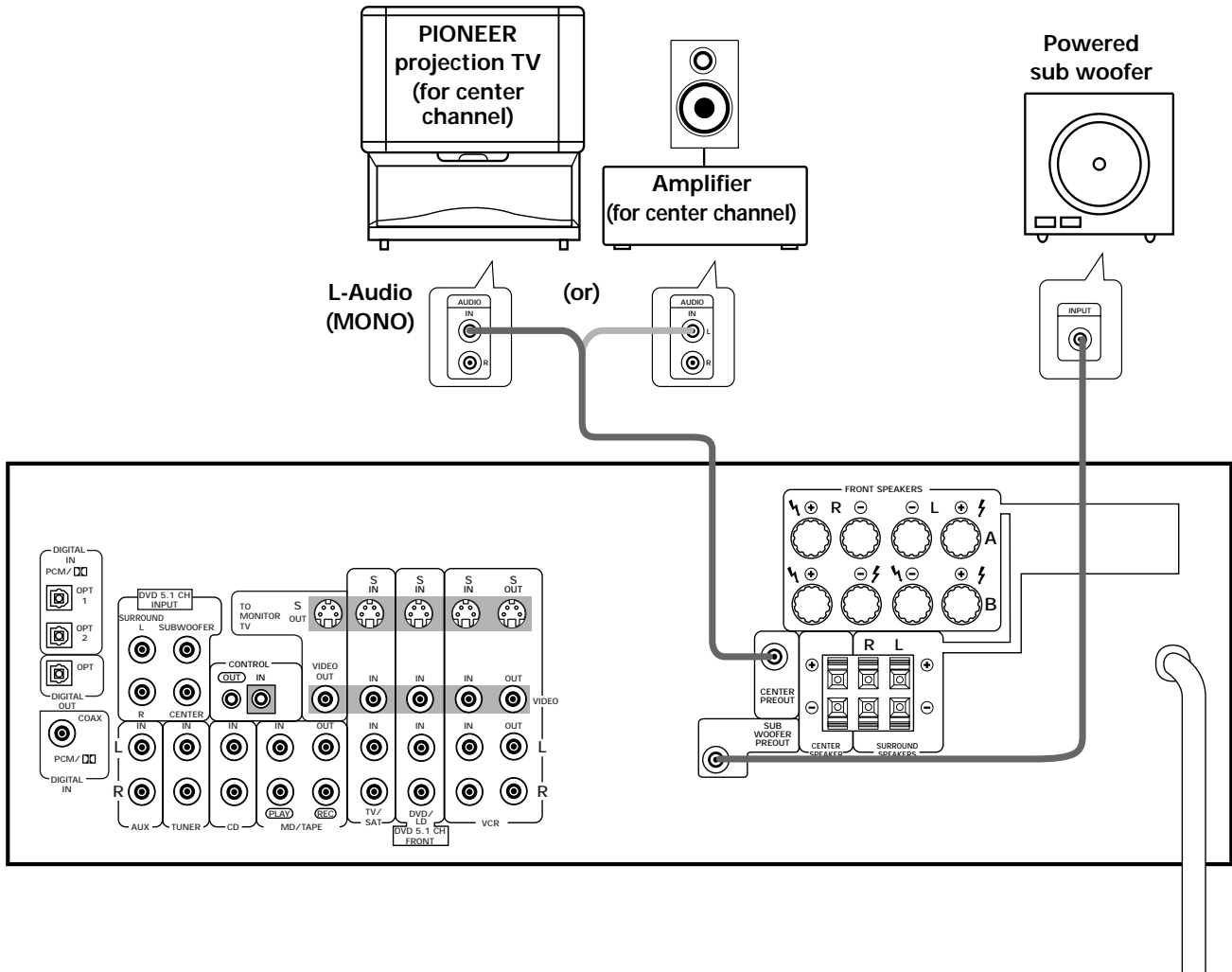

Be sure to complete all other connections before connecting this unit to the AC power source.

Speaker placement

To achieve the best possible surround sound, install your speakers as shown below. Be sure all speakers are installed securely to prevent accidents and improve sound quality.

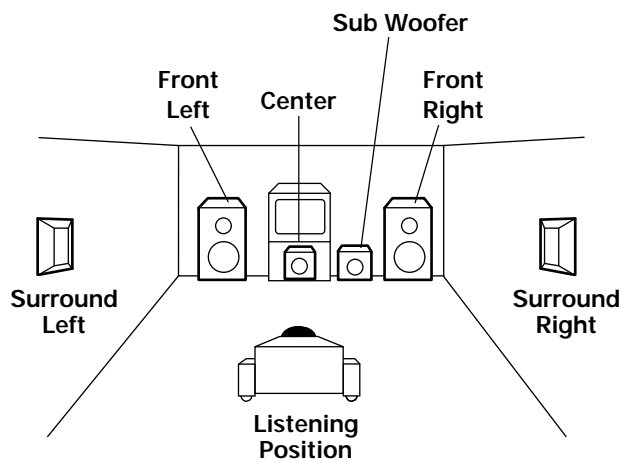

- Install the left and right front speakers at equal distances from the TV.
- When installing speakers near the TV, we recommend using magnetically shielded speakers to prevent possible interference such as distortion in the color of the TV screen. If you do not have magnetically shielded speakers and notice discoloration of the TV screen, place the speakers farther away from the TV.
- Install the center speaker above, below the TV so that the sound of the center channel is localized at the TV screen.

CAUTION:

When installing the center speaker on top of the TV, be sure to secure it with tape or some other suitable means.

Otherwise, the speaker may fall from the TV due to external shocks such as earthquakes, and it may lead to endangering those nearby or damaging the speaker.

- If possible, install the surround speakers slightly above ear level.
- It may be difficult to obtain a cohesive surround effect if the surround speakers are installed farther away from the listening position than the front and center speakers.

Setting Up for Surround Sound

Be sure to switch the power of this unit on (The **STANDBY** indicator goes out).

To ensure the best possible surround sound, be sure to complete the following set up operations. This is particularly important when using the **DD** (Dolby) Surround mode. You only need to make these settings once (unless you change the placement of your current speaker system or add new speakers, etc.). Refer to the following pages for detailed descriptions of the settings available for each mode.

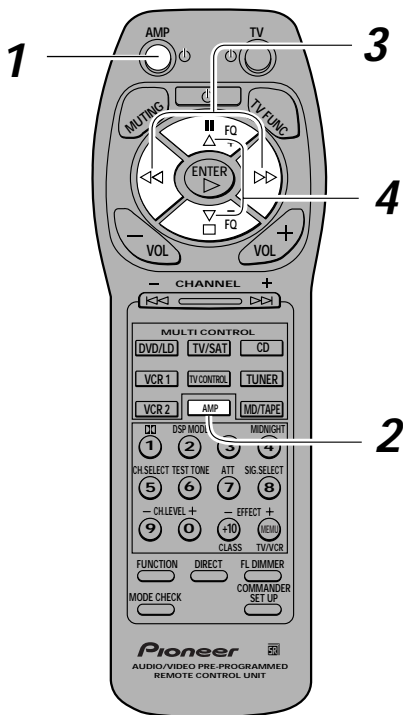

1 Press **AMP** to turn the power on.

The **STANDBY** indicator goes out.

2 Press **AMP**.

This switches the remote to the surround setup mode.

3 Press **<<** or **>>** to select the mode you desire.

For best results, start with "SPEAKER setting mode" and make your initial adjustments in the order described below.

The current settings are displayed automatically.

SPEAKER (Front, Center, Surround) setting mode (page 15)

Use to specify the type of speakers you have connected.

SUB WOOFER ON/OFF setting mode (page 16)

Use to specify the sub woofer as on or off.

Crossover frequency setting mode (page 16)

Use to determine which frequencies will be sent to the sub woofer or "Large" speakers.

LFE attenuator setting mode (page 16)

Use to specify the peak level for the LFE channel and the crossover network for rerouted bass frequencies.

Low cut filter ON/OFF setting mode (page 17)

Use to cut the distorted sound from the sub woofer.

FRONT speaker distance setting mode (page 17)

Use to specify the distance from your listening position to your front speaker.

CENTER speaker distance setting mode (page 17)

Use to specify the distance from your listening position to your center speaker.

SURROUND speaker distance setting mode (page 17)

Use to specify the distance from your listening position to your surround speakers.

Dynamic range control setting mode (page 18)

Use to compress the dynamic range of the sound track.

Coaxial digital input setting (page 18)

Use to specify the input to be assigned to the coaxial digital input.

Optical digital input 1 setting (page 18)

Use to specify the input to be assigned to the optical digital input 1.

Optical digital input 2 setting (page 18)

Use to specify the input to be assigned to the optical digital input 2.

4 Press **Δ** or **∇** to select the setting you desire.

The setting is entered automatically.

5 Repeat steps 3 and 4 to set other surround modes.



- Press **ENTER** to exit the setting mode.
- The setting mode is automatically exited if no operation is performed for 20 seconds.

SPEAKER setting mode

Establishes the size and configuration of the speaker system you have connected.

In the display, "F", "C", and "S" refer to front, center, and surround speakers respectively. Speaker size is denoted as "L" for large speakers, "S" for small speakers, and "*" (asterisk) if no speaker is connected.



If the cone size of your speaker is larger than 12 cm, please set to Large.

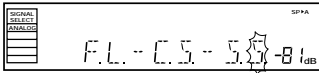
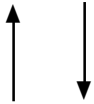
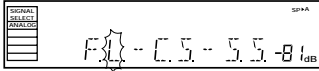

* Press $\triangleright\triangleright$ to advance to the next setting, and press $\triangleleft\triangleleft$ to return to previous setting.

1 Press \triangle or ∇ to set the front speaker.

Front speaker (initial setting is "L (Large)")

- Select "FL" if your speakers will reproduce bass frequencies effectively or if you did not connect a sub woofer.
- Select "FS" to send bass frequencies to the sub woofer. (The center and surround speakers cannot be set to Large if the front speakers are set to Small. In this case, all bass frequencies are sent to the sub woofer.)

2 Press \triangle or ∇ to set the center speaker.

Center speaker (initial setting is "L (Large)")

- Select "CL" if your speaker will reproduce bass frequencies effectively.
- Select "CS" to send bass frequencies to the other speakers or sub woofer.
- Select "C*" if you did not connect a center speaker. In this case, the center channel is output from the front speakers.

3 Press \triangle or ∇ to set the surround speaker.

Surround speaker (initial setting is "L (Large)")

- Select "SL" if your speakers will reproduce bass frequencies effectively.
- Select "SS" to send bass frequencies to the other speakers or sub woofer.
- Select "S*" if you did not connect surround speakers. In this case, the sound of the surround channels is output from the front and center speakers.

SUB WOOFER ON/OFF setting mode

Sets whether the SUB WOOFER is used or not.



- Initial setting is "ON".
- Setting the front speaker size to "Small" in the SPEAKER setting mode automatically locks the sub woofer in the "ON" position.

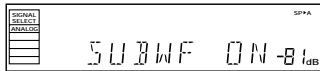

Press Δ or ∇ to select sub woofer ON or OFF.

Crossover frequency setting mode

Setting speakers to "Small" in "SPEAKER setting mode" sends the respective channels' bass frequencies to the sub woofer (or "Large" speakers). This function lets you determine which frequencies will be sent to the sub woofer or "Large" speakers.



- Initial setting is "100 Hz".
- If all speakers (front, center, and surround) are set to "Large" in SPEAKER setting mode, crossover frequency cannot be set. (***) appears in the display.)

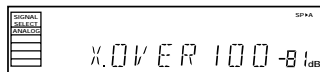

Press Δ or ∇ to specify the crossover frequency for your small speakers (100 Hz, 150 Hz or 200 Hz).

100 Hz

Sends bass frequencies below 100 Hz to the sub woofer (or Large speakers).

150 Hz

Sends bass frequencies below 150 Hz to the sub woofer (or Large speakers).

200 Hz

Sends bass frequencies below 200 Hz to the sub woofer (or Large speakers). We recommend setting 200 Hz when only small speakers are used.

LFE attenuator setting mode

Dolby Digital audio sources include ultra-low bass tones. Set the LFE attenuator as needed to prevent the ultra-low bass tones from distorting the sound from the speakers.



- Initial setting is "0 dB".
- When ∞ is selected (** appears in the display), LFE is not available.

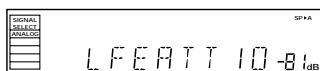

Press Δ or ∇ to set the attenuation level (0 dB, 10 dB or ** dB (∞)).

Low cut filter ON/OFF setting mode

Turn the low cut filter ON when distorted sound is output through the sub woofer.



- Initial setting is "OFF".
- If the SUB WOOFER is set to "OFF" in the SUB WOOFER ON/OFF setting mode, the low cut filter cannot be set.



Press Δ or ∇ to select low cut filter ON or OFF.

FRONT speaker distance setting mode

Sets the distance from the FRONT speaker to the listening position.



- Initial setting is 3 m.
- One step equals about 0.3 m.

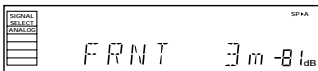

Press Δ or ∇ to set the distance of the FRONT speaker from the main listening position (up to 30 steps).

CENTER speaker distance setting mode

Normally as the Center speaker is placed directly in front in the listening room, it is closer to the listening position than the Front speakers. This means that the sound from the Center speaker will be heard before the Front speakers. To prevent this, set the Center speaker distance setting to delay the sound from the Center speaker so that the sound from the Front and Center speakers will be heard at the same time.



- Initial setting is 3 m.
- When "C*" is selected in SPEAKER setting mode, the Center distance cannot be set.
- One step equals about 0.3 m.

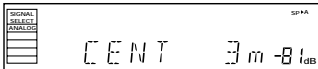

Press Δ or ∇ to set the distance of the CENTER speaker from the main listening position (up to 30 steps).

SURROUND speaker distance setting mode

Use to set the SURROUND speaker distance. Like the CENTER speaker position, the SURROUND speakers may be set in a location closer or farther than the FRONT speakers. Set the distance of the SURROUND speakers accurately to hear sounds coming from both FRONT and SURROUND speakers at the same time.



- Initial setting is 3 m.
- When "S*" is selected in SPEAKER setting mode, the SURROUND distance cannot be set.
- One step equals about 0.3 m.

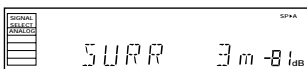

Press Δ or ∇ to set the distance of the SURROUND speaker from the main listening position (up to 30 steps).

Dynamic range control setting mode

Dynamic range is the difference between the loudest and softest sounds in any given signal. The dynamic range control helps you play back sounds so the quieter sounds are audible yet the louder sounds don't get distorted. It does this by compressing the dynamic range. When watching a movie at low volume, setting this function enables low level sounds to be heard more easily.



- Initial setting is "OFF".
- When the volume level is increased, set to OFF.
- For listening enjoyment at low volumes, set to "MAX" for maximum dynamic range compression.
- Dynamic range control is effective only when a Dolby Digital signal is being played back.

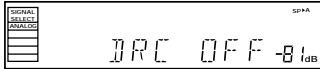

Press Δ or ∇ to set the dynamic range control (OFF, MAX, or MID).

Coaxial digital input setting

Sets the input component to be assigned to the coaxial digital input jack.



- Initial setting is "DVD".

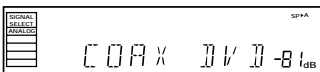

Press Δ or ∇ to select the coaxial digital input (DVD, TV, CD, MD, VCR, or OFF).

Optical digital input 1 setting

Sets the input component to be assigned to the optical input 1 jack.



- Initial setting is "CD".

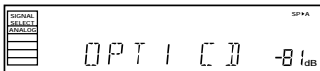

Press Δ or ∇ to select the optical digital input 1 (DVD, TV, CD, MD, VCR, or OFF).

Optical digital input 2 setting

Sets the input to be assigned to the optical input 2 terminal.



- Initial setting is "MD".
- You cannot assign the same component to more than one digital input jack. The jack most recently selected is established for the component and the jack formerly selected is turned off.
- DVD/LD, TV/SAT, CD, MD/TAPE, VCR digital input connection is possible.

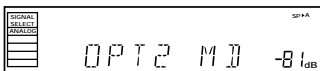

Press Δ or ∇ to select the optical digital input 2 (DVD, TV, CD, MD, VCR, or OFF).

Setting the volume level of each channel (Adjusting the speaker volume balance)



- Sound from the SUB WOOFER seems quiet.
- The speaker volume can be adjusted without outputting the test tone by pressing CHANNEL LEVEL or CHANNEL SELECT .
- Initial setting is 0 dB.

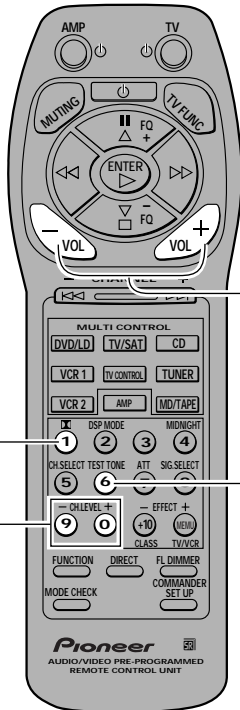

1 Press **□** .

2 Press **VOL +** or **-** to adjust the volume to an appropriate level.

3 Press **TEST TONE** to output the test tone.

The test tone is output in the following order.

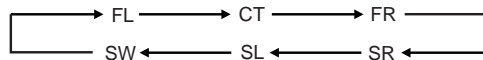

- Depending on the "SPEAKER setting mode" chosen, some channels may not output test tone (refer to page 15).
- Test tone is only output in Dolby Surround mode.

4 Adjust speaker levels so that you hear the test tone at the same volume from each speaker when seated in the main listening position.

The channel level ranges +10dB~ -10dB.



- Levels can be set for each surround mode.
- When both the DSP mode and Dolby Surround mode are turned on, priority is given to the Dolby Surround mode.

5 Press **TEST TONE** to turn off the test tone.

1

2

3,5

4

Setting Up the Remote Control

In addition to controlling the amplifier, the supplied remote control can operate your other components (DVD, MD, VCR, TV, LD, CD, etc.). If your component(s) are listed in the "Preset Code List" on page 44, simply recall the corresponding preset code. This remote control is factory set with the codes used to operate PIONEER components.

If you want to change the preset codes to operate components made by other manufacturers, follow the procedure outlined below.

Recalling preset codes

The following steps show you how to recall preset codes for each MULTI CONTROL button. Once the preset code is assigned, pressing the button will automatically set the remote to operate the respective component.



- Refer to "Preset Code List" on page 44 for the components and manufacturers available.
- Refer to "Remote Controlling Other Components" on pages 35 to 40 and "Background Control of Other Components" on page 41 for detailed explanations on how to operate your other components.

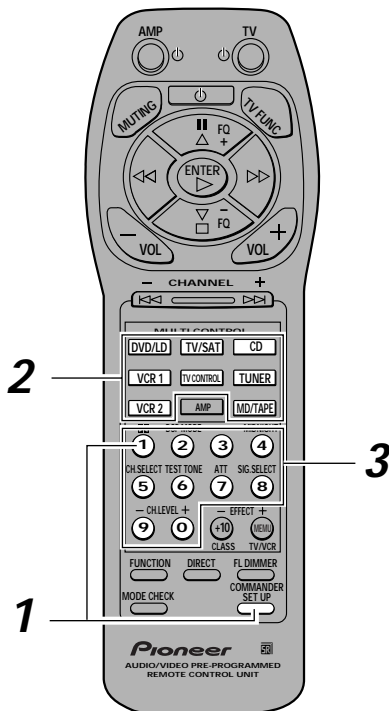

1 Press COMMANDER SET UP and 1 at the same time to select the preset mode.

The MULTI CONTROL buttons on the remote control start to blink.

To cancel the preset mode
Press COMMANDER SET UP.

2 Press the MULTI CONTROL button for the component you want to control.

Each button can be set to control one of the following components

- DVD/LD** : DVD/LD player
- TV/SAT** : TV or Satellite tuner
- CD** : CD player
- TUNER** : Tuner
- MD/TAPE** : MD recorder or Tape recorder
- VCR 1** : Video deck
- VCR 2** : Video deck
- TV CONTROL** : TV or Cable TV tuner

3 Point the remote control toward the component to be controlled, enter the 3 digit setup code.

When a three digit code number is input, a power ON/OFF signal is output from the remote control unit. If the power of the device turns ON or OFF corresponding to this signal, it indicates that the device has been set properly. If the power does not turn ON/OFF, input another code.

Repeat steps 2 through 3 to assign preset codes for as many components as necessary.

4 Press COMMANDER SET UP to exit the preset mode.

The remote control returns to the previous operation mode.



- When operating a PIONEER'S DVD/LD player, set the manufacturer code to "000" in the preset mode.
- AMP button cannot be preset.

Clearing the Remote Control Settings

Clears all presets and restores factory installed presets.

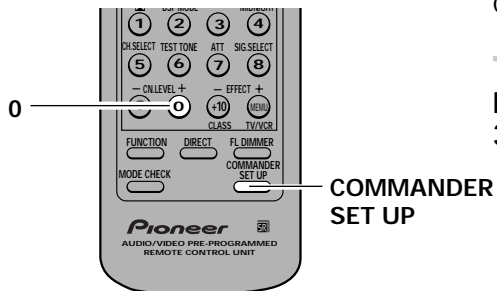

Press **COMMANDER SET UP** and **0** at the same time for more **3 seconds**.

- All the multi-control buttons on the remote control blinks. After blinking three times, all the settings are canceled.

Display

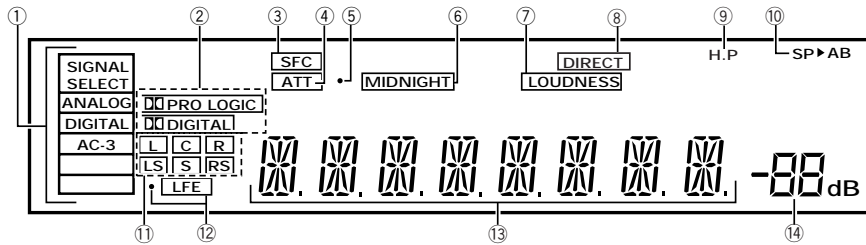

① SIGNAL SELECT indicators

Light to indicate the type of input signal selected for the current component (refer to "Front Panel", ⑫, SIGNAL SELECT on page 24).

ANALOG : Lights when the analog audio signals are selected.

DIGITAL : Lights when the digital audio signals are selected.

AC-3 : Lights when a source with Dolby Digital signals is played.

② Digital indicators

PRO LOGIC : When the Dolby Surround mode on the amplifier is on, this indicator lights during 2 channel playback of Dolby Digital sources.

DIGITAL : When the Dolby Surround mode on the amplifier is on, this indicator lights to indicate playback of a Dolby Digital signal. However, **PRO LOGIC** lights during 2 channel playback of Dolby Digital.

③ SFC (DSP) mode indicator

Lights when the DSP mode is selected (refer to on page 26).

④ ATT indicator

Lights when ATT (refer to "Remote Control", ⑦, Number buttons on page 23) is used to reduce the level of the input signal (available in ANALOG mode only).

⑤ Overload indicator

When "ANALOG" is selected in SIGNAL SELECT, this indicator lights to show that an excessively strong signal is being processed. When this occurs, press ATT on the remote control to attenuate the signal (refer to "Remote Control", ⑦, Number button on page 23).

⑥ MIDNIGHT indicator

Lights when the MIDNIGHT mode is on. (refer to "Front Panel", ⑭, MIDNIGHT on page 25).

⑦ LOUDNESS indicator

Lights when loudness is on. (refer to "Front Panel", ⑨, LOUDNESS on page 24).

⑧ DIRECT indicator

Lights when direct playback is on (refer to "Front Panel", ⑨, DIRECT on page 25).

⑨ H.P indicator

Lights when headphones are plugged in.

⑩ Speaker indicators

Light to indicate the current speaker system (refer to "Front Panel", ⑤, SPEAKERS (A/B) on page 24).

SP ▶ A : Lights when speaker system A is selected.

SP ▶ B : Lights when speaker system B is selected.

⑪ Program format indicators

The following indicators light to show the channels being played back.

L : Left front^{*1*2}, **C** : Center^{*1}, **R** : Right front^{*1*2}, **LS** : Left surround^{*1}, **S** : Surround (mono)^{*2}, **RS** : Right surround^{*1}

*1: Indicates 5.1ch Dolby Digital playback.

*2: Indicates Dolby Pro Logic playback.

⑫ LFE indicator

LFE (Low Frequency Effects) indicator lights to indicate that the program source contains an LFE channel. The indicator to the left of LFE lights during actual playback of the LFE signals (LFE signals are not present in all parts of the sound track).

⑬ Character display

⑭ Volume level display

Displays the volume level. Volume level is maintained even when the power is off. --dB indicates the minimum level, and 0dB indicates the maximum level.

- Depending on the level settings for individual channels, the MAX level can range between -10dB and 0dB.

Remote Control

These pages describe the buttons on the remote control used to operate the amplifier.

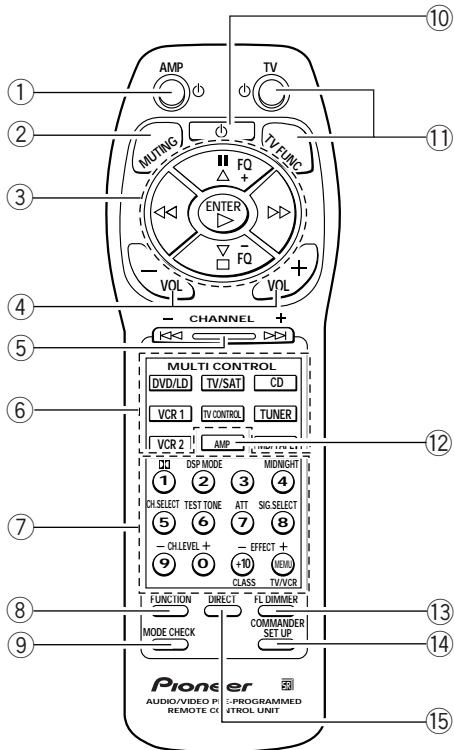

① AMP button

Press to switch the amplifier on or to put in standby.

② MUTING button

Press to mute the volume. "MUTING" appears in the display. Press again to cancel.

③ [When set to SURROUND]

◀, ▶, △, ▽, (Select/Adjust) buttons

[When set to other than OPERATIONS]

⏸ (Pause), ⏹ (Stop), ⏮ (Rewind), ⏭ (Fast Forward), ENTER/▶ (Play) buttons

[Tuner Operations]

FQ + (to higher frequencies), FQ - (to lower frequencies), ⏮ (MPX), ⏭ (DISP MODE), ▶ (FM/AM) buttons

⏮ (MPX): Use to switch the auto stereo/monaural mode for receiving FM broadcasts. When the received broadcast signal is weak, press this button to set the monaural mode.

⏭ (DISP MODE): Use to switch the RDS data while listening to an FM station. Each press changes the display in the order of RT, PS, PTY, and frequency.

④ VOL (-/+) buttons

Press to adjust the volume. When VOL (-/+) buttons are pressed while muting, muting is canceled.

⑤ CHANNEL (-/+) button

Use to select preset stations when operating the tuner. When the remote is used to control other components, this button may be used to change channels, tracks, or chapters.

⑥ MULTI CONTROL buttons

Use these buttons to select the remote operation mode.

For example, pressing TUNER sets the remote to operate the tuner functions.

⑦ Number buttons

These buttons can perform a variety of different functions depending on the remote operation mode.

• [AMPLIFIER operations (press AMP first)]

⏸ : Switches the Dolby Surround mode on or off (refer to page 29).

DSP MODE : Press repeatedly to select a DSP sound mode (refer to page 26, 30).

MIDNIGHT : Press to hear surround sound effectively at low volumes (refer to page 31).

CH.SELECT : Use to select a speaker when adjusting speaker levels.

TEST TONE : Press to switch the test tone on or off when listening to a surround mode (refer to page 19).

ATT : Press to attenuate (lower) the level of the input signals and prevent distortion (refer to "Display", ⑤, Overload indicator on page 22).

SIG.SELECT : When the same component uses both analog and digital connections, use to select input signals as digital or analog.

CH.LEVEL (-/+) : Use to adjust individual speaker levels after having pressed CH. SELECT to select a speaker channel.

EFFECT (-/+) : Use to adjust the DSP mode effect level.

⑧ FUNCTION button

Press repeatedly to select a source.

⑨ MODE CHECK button

Press to confirm the current remote operation mode and to switch operation modes without changing the source (refer to page 41).

⑩ Power button

Press to turn on or put in standby all connected components other than this unit.

⑪ TV, TV FUNC button

Press TV to turn the TV's power on or put in standby. Press TV FUNC to select the TV for remote control operation.

⑫ AMP button

Press to select the amplifier for remote control operation.

⑬ FL DIMMER button

Press to adjust the brightness of the fluorescent display. Four levels of brightness ranging from very dim to very bright can be selected.

⑭ COMMANDER SET UP button

Use to customize the remote control functions. (Refer to "Setting Up the Remote Control" starting on page 20).

⑮ DIRECT button

Use to playback original source audio. When DIRECT is ON, Dolby Surround, DSP, LOUDNESS, and MIDNIGHT mode are automatically turned OFF.

Front Panel

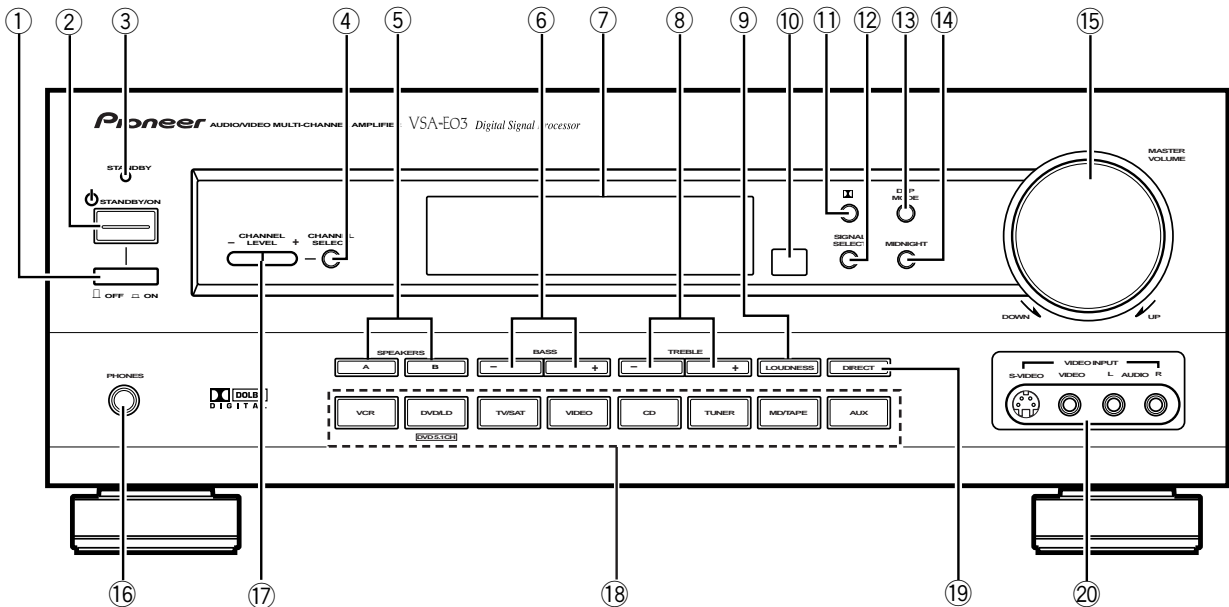

- ① **Main power switch (■ OFF, ▬ ON)**
- ② **STANDBY/ON button**
Press to switch the amplifier on or put in standby.
- ③ **STANDBY indicator**
Lights when the amplifier is in standby mode. (Please note that this amplifier consumes a small amount of power (2 W) during the standby mode.)
- ④ **CHANNEL SELECT button**
Use to select a speaker when adjusting speaker levels.
- ⑤ **SPEAKERS (A/B) buttons**
Use to switch the corresponding speaker system on or off. To listen to both speaker systems (A and B), press the buttons so that both A and B appear in the display (refer to "Display", ⑩, Speaker indicators on page 22). Only A speakers are available when using surround sound modes.
- ⑥ **BASS (-/+) button**
Press to adjust low frequencies in the range of ± 6 .
- ⑦ **Display (Refer to page 22)**
- ⑧ **TREBLE (-/+) button**
Used to adjust high frequencies in the range of ± 6 .
- ⑨ **LOUDNESS button**
Switches the loudness on or off. Use to raise the level of the bass and treble so they can be more easily heard when listening at low volumes.
- ⑩ **Remote sensor**
Point the remote control toward the remote sensor to operate the amplifier.
- ⑪ **Dolby Surround button**
Press to select the (Dolby) Surround mode. This mode automatically switches between Dolby Digital and Dolby Pro Logic decoding according to the input signal. (Refer to page 29 for more information about Dolby Digital.)
- ⑫ **SIGNAL SELECT button**
Use to select input signals for the digital components. First press VCR, DVD/LD, TV/SAT, CD or MD/TAPE (⑱, Function buttons) to select the component, then press SIGNAL SELECT repeatedly to select one of the following:
ANALOG : Selects the analog (R and L) audio signals.
DIGITAL : Selects the digital audio signals. This amplifier automatically detects and displays the format of the signal being input. AC-3 lights when Dolby Digital signals are input. (AC-3 decoding is switched automatically.)
 - SIGNAL SELECT is fixed in the "ANALOG" position for components not assigned to one of the three digital input jacks.
 - Because the audio from a karaoke microphone and LD recorded with analog audio only is not output from the digital output, set SIGNAL SELECT to "ANALOG".
 - This amplifier can only play back Dolby Digital, PCM (32kHz, 44kHz, and 48kHz) signal formats. With digital signal formats other than these, set SIGNAL SELECT to "ANALOG".
- ⑬ **DSP MODE button**
Press repeatedly to select a DSP sound mode (HALL 1, HALL 2, JAZZ, DANCE, THEATER 1, or THEATER 2). Use these modes to produce surround sound from standard (two channel) stereo sources (refer to page 26, 30).

- ⑭ **MIDNIGHT button**
Press to hear effective surround sound at low volume levels. The effect is automatically adjusted according to the volume level.
- ⑮ **MASTER VOLUME**
After turning on the desired component, rotate to adjust the volume.
- ⑯ **PHONES jack**
Connect headphones for private listening (the speakers turn off automatically).
- ⑰ **CHANNEL LEVEL (-/+) button**
Use to adjust individual speaker levels after having pressed CHANNEL SELECT to select a speaker channel.
- ⑱ **Function buttons**
Selects the function. Each press switches the DVD/LD input between DVD/LD and DVD 5.1 channel.
- ⑲ **DIRECT button**
Switches direct playback on or off. Use to bypass the amplifier's tone control circuitry or level control for higher fidelity to the program source. When DIRECT is ON, Dolby Surround, DSP, LOUDNESS, and MIDNIGHT mode are automatically turned OFF.
- ⑳ **VIDEO INPUT jacks**
Connect a video camera, video game system, etc. to the VIDEO INPUT jacks (refer to page 8).

Sound Modes

This amplifier incorporates two surround modes for enjoyment of a variety of program sources.

Surround modes

(Dolby) Surround mode

Use this mode when playing Dolby Digital or Dolby Surround software. Decoding switches automatically according to the input signal, so all you have to do is enjoy!

You can identify Dolby Digital software by the  or  marks. Most Dolby Surround software is marked , but unmarked software may also incorporate Dolby Pro Logic.

For more information about Dolby formats, refer to page 42.

DSP modes

The DSP (Digital Signal Processing) modes allow you to transform your living room into a variety of different sonic environments when playing standard (two-channel) stereo sources, Dolby Surround sources, and Dolby Digital sources.

HALL 1

Simulates the acoustic environment of a large concert hall of wooden construction. Complex delay of reflected sounds coupled with reverberation effects create a dynamic and beautiful sound characteristic of an orchestra performing in a concert hall, making it suitable for classical music.

HALL 2

Simulates the acoustic environment of a concert hall with stone walls. The rich reverberations and natural fullness of the sound create the auditory impression of being in a concert hall, making it suitable for classical music.

JAZZ

Simulates the acoustic environment of a jazz club. Less delay on the reflected sounds emphasizes the sensation of hearing a live band.

DANCE

Simulates the acoustic environment and strong bass sound of a nightclub with a square dance floor. A short delay on the reflected sounds emulates the raw power of the dance music.

THEATER 1

Adjusts the delay of the reflected sound to simulate the acoustic environment of a medium sized movie theater.

THEATER 2

Simulates the acoustic environment of a theater while maintaining proper localization of each channel.

Switching ANALOG/DIGITAL Signal Input

The input of the component set in the digital input setting (Refer to page 18) can be switched to an analog or digital input signal by pressing the SIGNAL SELECT button.

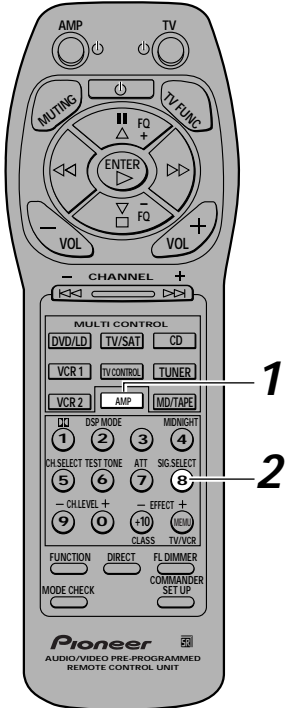

1 Press AMP.

This sets the remote to select the sound mode.
(You can skip this step when using the controls on the amplifier.)

2 Press SIG. SELECT on the remote control or SIGNAL SELECT on the front panel to select the input signal corresponding to the source component.

Each press switches between ANALOG and DIGITAL signal selection.

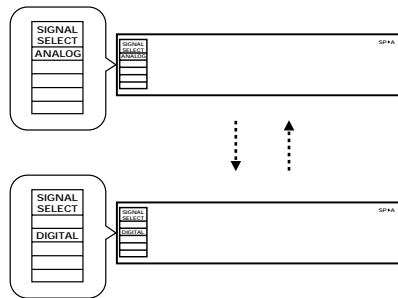

3 While SIGNAL SELECT is set to DIGITAL, AC-3 lights when a Dolby Digital is input.

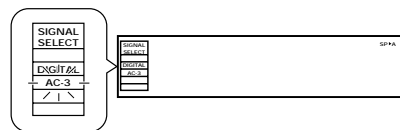

When a Dolby Digital signal is input.

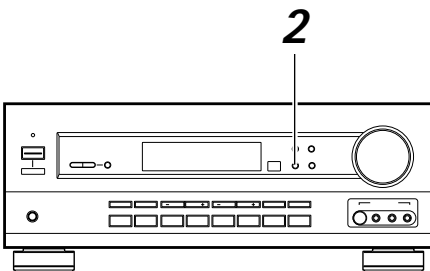

- SIGNAL SELECT is fixed in the "ANALOG" position for components not assigned to one of the three digital input jacks.
- Because the audio from a karaoke microphone and LD recorded with analog audio only is not output from the digital output, set SIGNAL SELECT to "ANALOG".
- This amplifier can only playback Dolby Digital, PCM (32kHz, 44kHz, and 48kHz) signal formats. With digital signal formats other than these, set SIGNAL SELECT to "ANALOG".

Playback

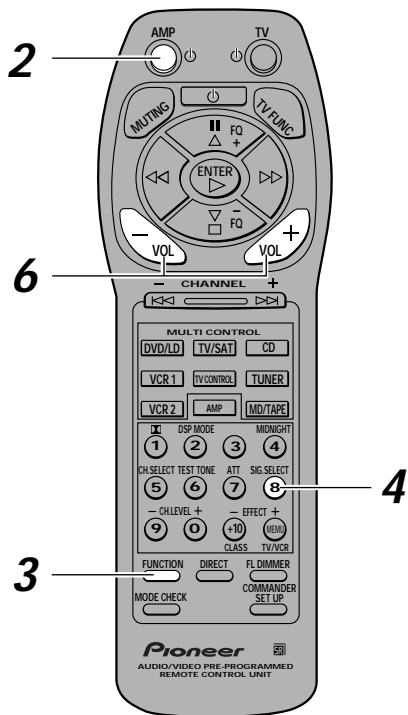

1 Turn on the power of the playback component.

2 Press **AMP** to turn on the amplifier.

Be sure that the standby indicator turns off on the front panel.

STANDBY indicator

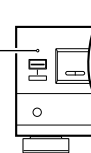

3 Press **FUNCTION** to select the source you want to playback.

The source you want to playback is displayed in the following order:

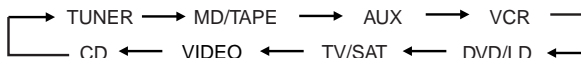

4 Press **SIG. SELECT** on the remote control or **SIGNAL SELECT** on the front panel to select the input signal corresponding to the source component.

(Refer to "Switching ANALOG/DIGITAL signal input" on page 27.)

5 Start playback of the component you selected in step 1.

6 Press **VOL (-/+)** to adjust the volume level in the range of --- dB (MIN) to 0 dB (MAX).

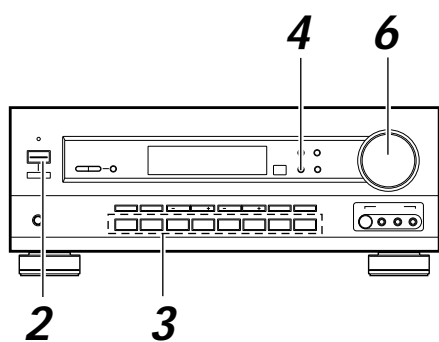

- Depending on the channel level setting, the MAX volume level may differ 0 to -10 dB from the level displayed.
- When this amplifier is not going to be used for a long time, it is recommended that you turn off the main power.

Playing Sources with Dolby Digital

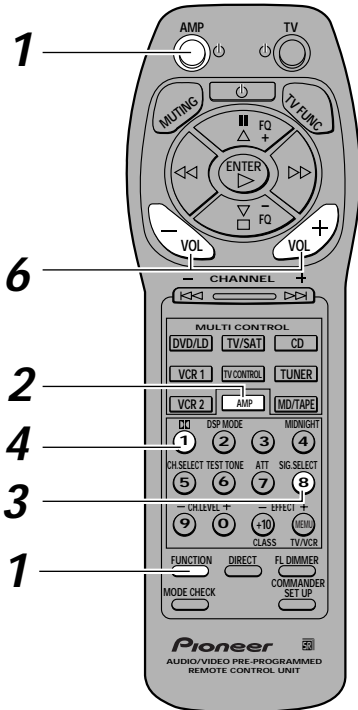

1 Follow steps 1 to 3 of the playback procedure. (Refer to “Playback” on page 28.)

- ① Turn on the power of the playback component.
- ② Press **AMP** to turn on the amplifier.
- ③ Press **FUNCTION** to select the source component you want to play.

2 Press **AMP**.

This sets the remote to select the sound mode.
(You can skip this step when using the controls on the amplifier.)

3 Press **SIG.SELECT** on the remote control or **SIGNAL SELECT** on the front panel to select **DIGITAL**.

(Refer to “Switching ANALOG/DIGITAL signal input” on page 27.)

4 Press **[DOLBY SURROUND]** to switch the Dolby Surround mode on.

Each press changes the Dolby Surround mode.

5 Start playback of the component you selected in step 1.

6 Press **VOL (-/+)** to adjust the volume level.

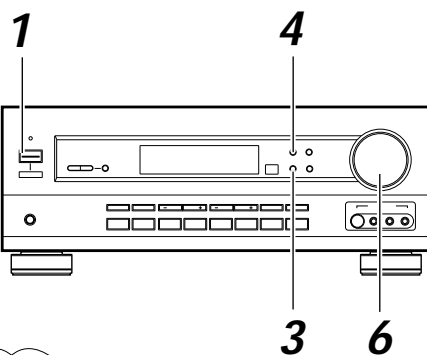

When playing LD recorded in Dolby Digital

When connecting a DVD/LD player or LD player using the AC-3 RF output, a commercially available RF demodulator (RFD-1) is required. The RF demodulator changes the RF signal to a digital signal which is then processed by the amplifier at the digital input jacks. For more details, refer to the instruction manual supplied with the RFD-1.

Refer to pages 42 for explanations of Dolby Digital, Dolby Pro Logic.

Selecting a Sound Mode

To ensure the best possible surround sound, be sure to complete the set up procedures described in "Setting Up for Surround Sound" (starting on page 14) before using the sound modes. This is particularly important when using the  (Dolby) Surround mode. When using the sound modes, SPEAKERS A are used. If SPEAKERS B are selected and a sound mode is turned on, selection automatically switches to SPEAKERS A only.

Surround operation

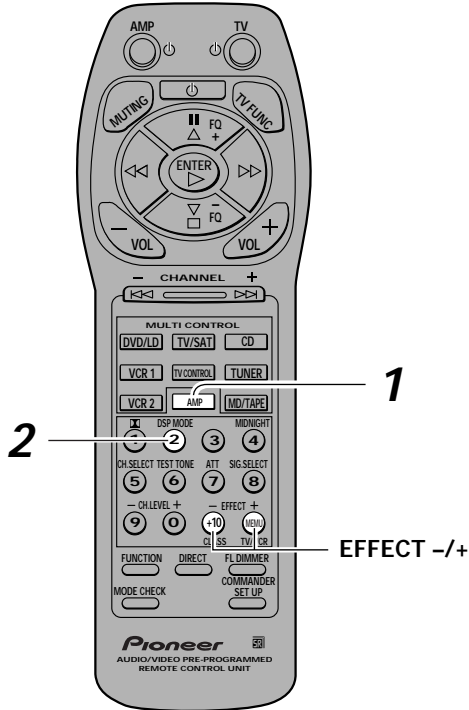

1 Press AMP.

This sets the remote to select the sound mode.
(You can skip this step when using the controls on the amplifier.)

2 Press DSP MODE to select the sound mode.

Each press changes the DSP mode as follows:

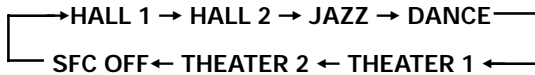

- The amount of effect of each DSP mode can be adjusted in the range of 10 to 90 (the default setting value is 70) by pressing EFFECT +/-.

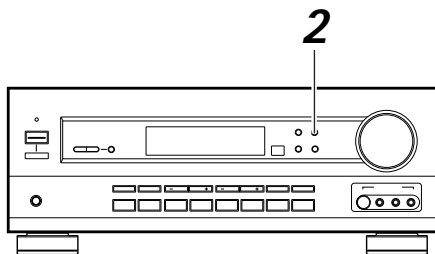

DVD 5.1ch input playback

Connect a component with 5.1 channel output to enjoy the surround sound created by 5.1 channel playback.

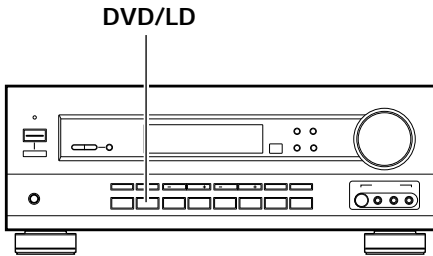

Press DVD/LD on the unit.

Each press switches the input: DVD/LD ↔ DVD 5.1ch



- When DVD 5.1ch input is selected, Dolby Surround mode, DSP mode, SIGNAL SELECT, ATT, DIRECT, TONE, MIDNIGHT mode, and speakers B cannot be operated.
- When DVD 5.1ch input is selected, only the volume level, channel levels and LOUDNESS can be set.

Listening in MIDNIGHT Listening Mode

When the volume is low, surround effects tend to become less than satisfactory. Turn the MIDNIGHT listening mode on to enjoy the effects of quality surround sound even at low volumes. This mode allows you to hear effective surround sound of movies at low volume levels.

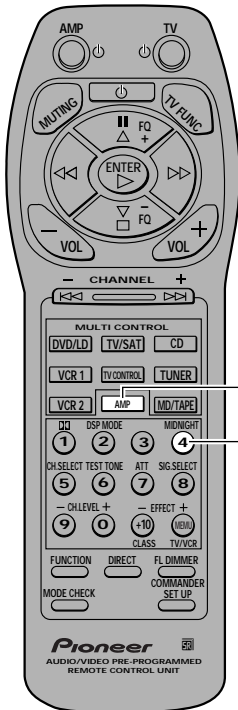

1 Press AMP.

This sets the remote to select the sound mode.
(You can skip this step when using the controls on the amplifier.)

2 Press MIDNIGHT.

Each press switches MIDNIGHT listening mode on or off.



The effect automatically adjusts according to the volume level.

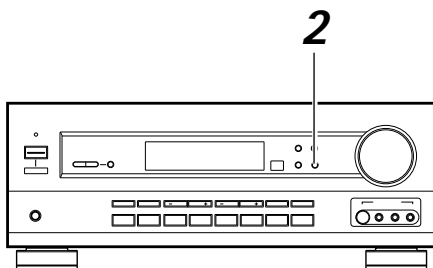

Adjusting bass and treble (tone control)

Use BASS (-/+) or TREBLE (-/+) to adjust the low and high frequencies.

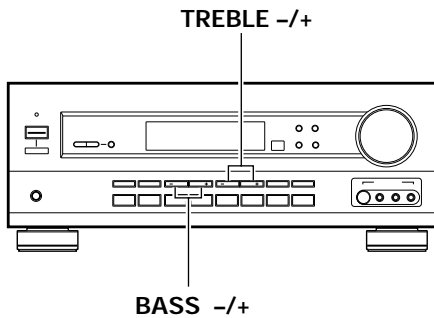

Press BASS (-/+) to adjust the low frequencies.

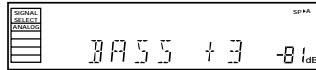

Press TREBLE (-/+) to adjust the high frequencies.

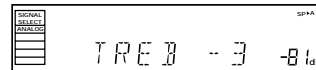

- The tone control can be adjusted in a range of ± 6 .
- Pressing + and - simultaneously restores the setting to 0.
- In cases described below, the tone control cannot be adjusted.
 - ① Dolby Surround mode is ON.
 - ② DSP mode is ON.
 - ③ DVD 5.1ch input is selected.
 - ④ Dolby Digital signals are being input.

Adjusting the brightness of the display

Use FL DIMMER to adjust the brightness of the fluorescent display.

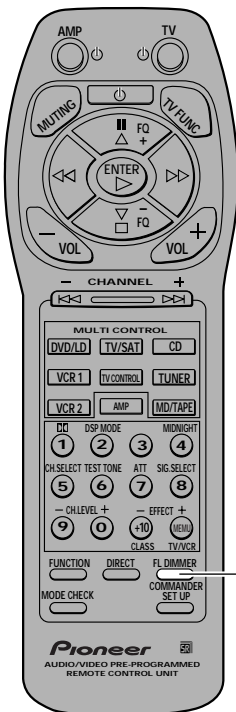

Press FL DIMMER.

Four levels of brightness ranging from very dim to very bright can be selected. Each press changes the brightness of the display. When rotating through the options, the default brightness can also be selected.



In standby, pressing \odot STANDBY/ON while holding down \square (Dolby Surround button (both on the front panel)) returns the display to the default brightness.

Recording from Audio Components

The following operations show you how to record audio to the cassette, DAT, or MD deck connected to the MD/TAPE jacks.



The amplifier's volume, tone (BASS, TREBLE, MIDNIGHT and LOUDNESS), and surround effects have no effect on the recorded signal.

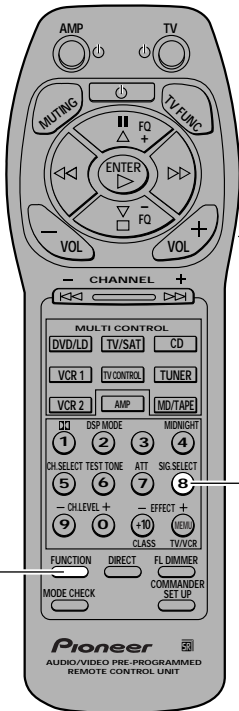

1 Prepare the program source.

(Tune in the radio station or load the CD, etc.)

2 Select the component you want to record.

Press SIG. SELECT on the remote or SIGNAL SELECT on the front panel to select "ANALOG" when making analog recordings, or "DIGITAL" when making digital recordings. (Refer to "Switching ANALOG/DIGITAL signal input" on page 27.)

3 Insert a blank tape into the cassette deck (MD/TAPE) and adjust the recording level (if necessary).

4 Start recording on the cassette deck, then start playback from the source component.

2

SIG. SELECT



- This amplifier outputs the input signal directly to the recording device. As there is no conversion of the audio signal, recordings cannot be made from analog to digital, and similarly from digital to analog.
- Recording cannot be made from MD/TAPE.

SIGNAL SELECT

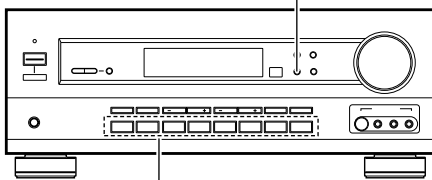

2

Recording from Video Components

The following operations show you how to record audio and video to the video tape recorder connected to the VCR jacks.



The amplifier's volume, tone (BASS, TREBLE, MIDNIGHT and LOUDNESS), and surround effects have no effect on the recorded signal.

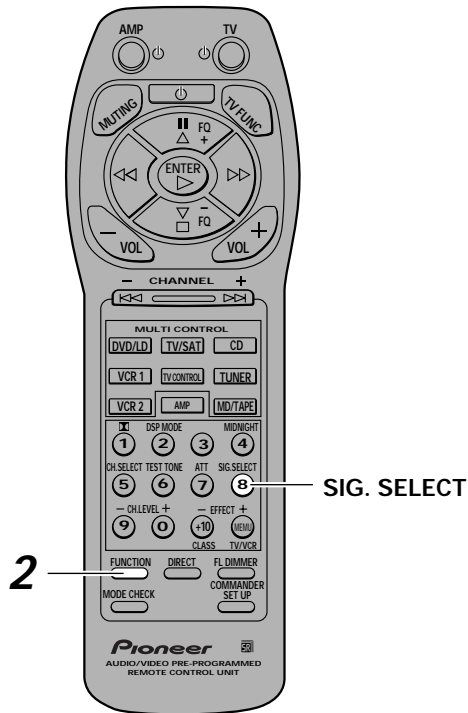

1 Prepare the program source.

(Load the DVD or LD, etc.)

2 Select the component you want to record.

Be sure to press SIG. SELECT on the remote or SIGNAL SELECT on the front panel to choose "ANALOG". (Refer to "Switching ANALOG/DIGITAL signal input" on page 27.)

3 Insert a blank tape into the video tape recorder VCR.

4 Start recording on the video tape recorder, then start playback from the source component.



- Recording cannot be made from analog to digital, and similarly from digital to analog.
- When recording a DVD, the recorded image may flicker or be difficult to view because of the copy protection signal programmed on the DVD.

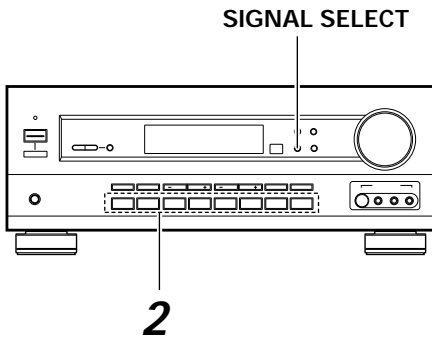

Remote Controlling Other Components

DVD or LD player operations



Before attempting to perform these operations, press the DVD/LD (MULTI CONTROL) button to switch the remote to the DVD/LD operation mode.

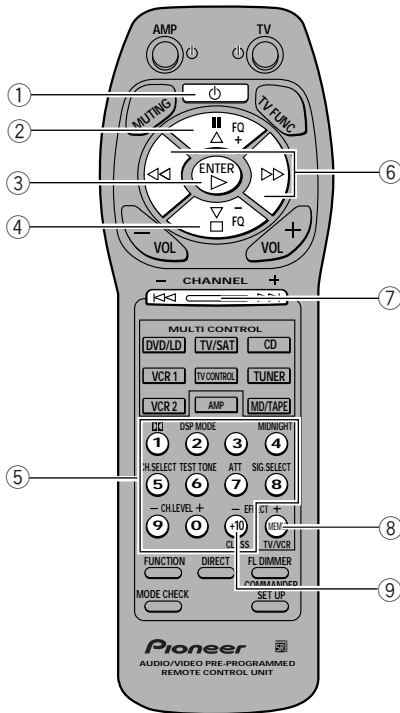

- ① Press to switch the DVD or LD player on or off.
- ② Press to pause playback. (With certain models, this button may freeze the frame.)
- ③ Press to start playback.
- ④ Press to stop playback. (With certain models, pressing this button when the unit is stopped may open the disc tray.)

⑤ Number buttons

Use to select chapters (tracks).

⑥

: Hold down for fast reverse playback.
: Hold down for fast forward playback.

⑦

: Press to return to the beginning of the current chapter (track). Press repeatedly to return to the beginning of previous chapters (tracks).
: Press to advance to the beginning of the next chapter (track). Press repeatedly to advance to the beginning of following chapters (tracks).

⑧ MENU

LD : Switches between sides A and B of the disc.
 DVD : Switches the menu screen on and off.

⑨ +10

Use when selecting chapter (track) numbers higher than 10.

To select chapter (track) 34, press :
 +10 → +10 → +10 → 4

To select chapter (track) 20, press :
 +10 → +10 → 0



Press DVD/LD (MULTI CONTROL) two times in succession to make the buttons blink. While the buttons are blinking, you can operate the player by pressing the following buttons.

- ② : , ③ : ENTER, ⑥ : , ⑧ : MENU key
 ⑨ : title key

Pressing the DVD/LD button again or not pressing any buttons for 30 seconds returns the remote control to its former condition.

*With some Pioneer DVD and DVD/LD players, cursor operation can be performed without pressing DVD/LD.

SAT (Satellite Tuner) operations



- The following operations are available from the amplifier's remote control after you recall a Satellite tuner preset code (refer to "Setting Up the Remote Control" on page 20).
- Before performing these operations, press the TV/SAT (MULTI CONTROL) button to switch the remote to the TV/SAT operation mode.

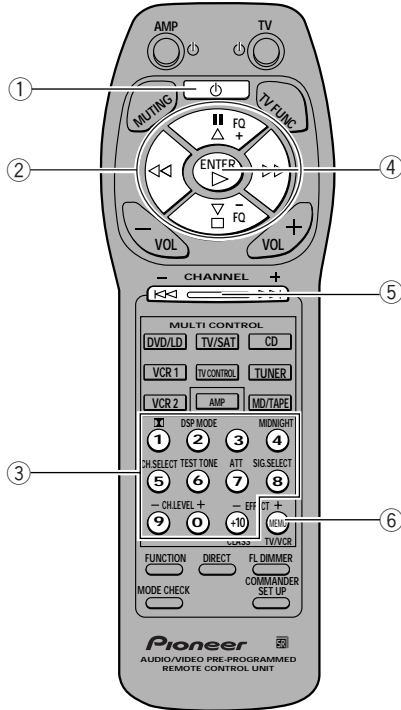

- ① **⏻**
Press to switch the satellite tuner on or off.
- ② **▲/▼/◀/▶**
Use as cursor buttons to obtain information about programs.
- ③ **Number buttons**
Use to select satellite channels.
- ④ **ENTER**
Press to select the position selected using the cursor buttons (▲/▼/◀/▶).
- ⑤ **◀◀/▶▶ (GUIDE)**
Use to turn the program information screen on or off.
- ⑥ **DISC (MENU)**
Use to turn the main menu on or off.

TV operations



Before attempting to perform these operations, press TV CONTROL or TV/SAT (MULTI CONTROL) to switch the remote to the TV operation mode.

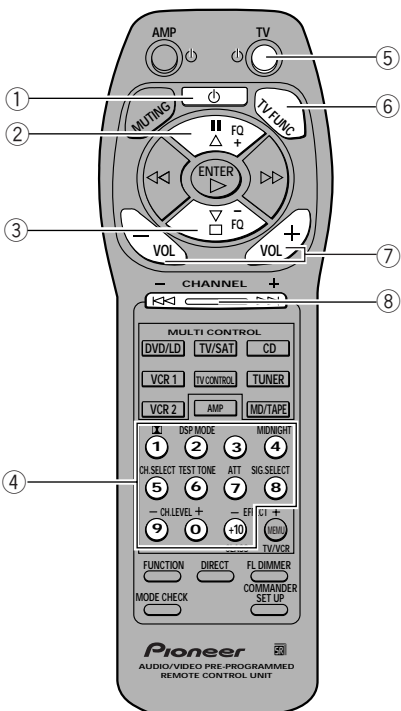

- ① **⏻**
Press to switch the TV on or off.
- ② **▲**
Raises the volume of the TV.
- ③ **▼**
Lowers the volume of the TV.
- ④ **Number buttons**
Use to select a specific TV channel.
- ⑤ **TV**
Press to switch the TV on or off. (This operation is possible regardless of the current remote operation mode, however, it can only be used with the component assigned to TV CONTROL.)
- ⑥ **TV FUNC**
Press to switch the TV's input (not possible with all models). (This operation is possible regardless of the current remote operation mode.)
- ⑦ **VOL (+/-)**
Use to adjust the volume of the TV.
- ⑧ **CHANNEL (+/-)**
Use to select a TV channel.

CD player operations



Before performing these operations, press the CD (MULTI CONTROL) button to switch the remote to the CD operation mode.

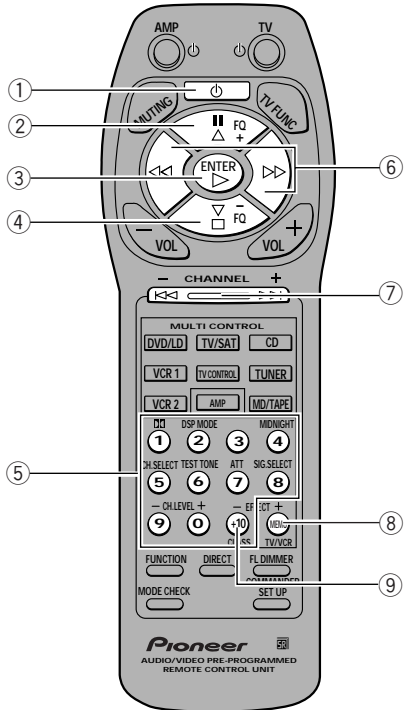

- ① Press to switch the CD player on or off.
- ② Press to pause playback.
- ③ Press to start playback.
- ④ Press to stop playback.
- ⑤ **Number buttons**
Use to select tracks.
- ⑥
 - : Hold down for fast reverse playback.
 - : Hold down for fast forward playback.
- ⑦
 - : Press to return to the beginning of the current track. Press repeatedly to return to the beginning of previous tracks.
 - : Press to advance to the beginning of the next track. Press repeatedly to advance to the beginning of following tracks.
- ⑧ **MENU**
For multi-disc CD changers, use to select the disc numbers (not possible with all models).
For example, to select disc 34, press :
3 → 4 → MENU.
- ⑨ **+10**
Use when selecting track numbers higher than 10.
For example, to select track 34, press :
+10 → +10 → +10 → 4

TUNER operation



Only PIONEER products can be operated.
Set the input source to TUNER, and operate as desired using the following buttons.

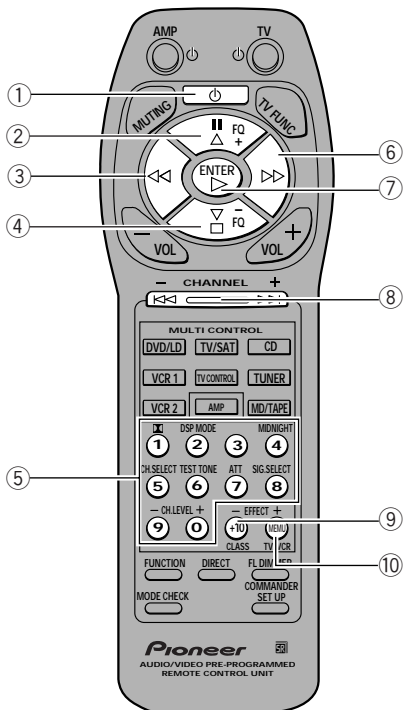

- ① Press to switch the tuner on or off.
- ② **FQ +**
Shifts the frequency up.
- ③ Use to switch the auto stereo/monaural mode for receiving FM broadcasts. When the received broadcast signal is weak, press this button to set the monaural mode.
- ④ **FQ -**
Shifts the frequency down.
- ⑤ **Number buttons**
Use to select station call.
- ⑥ Use to switch the RDS data while listening to an FM station. Each press changes the display in the order of RT, PS, PTY, and frequency.
- ⑦ **ENTER (AM/FM select button)**
- ⑧ **CHANNEL +/-**
Use to select stations in the current CLASS.
- ⑨ **CLASS**
Use to switch between preset station memory classes 1 to 3.
- ⑩ **MENU**
Use to select the Direct Tuning.

MD recorder operations



Before performing these operations, press the MD/TAPE (MULTI CONTROL) button to switch the remote to the MD/TAPE operation mode.

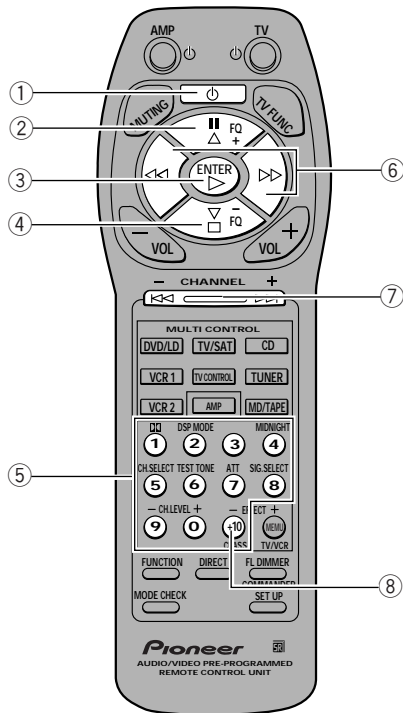

- ① Press to switch the MD recorder on or off.
- ② Press to pause playback.
- ③ Press to start playback.
- ④ Press to stop playback.
- ⑤ **Number buttons**
Use to select tracks.
- ⑥
 : Hold down for fast reverse playback.
 : Hold down for fast forward playback.
- ⑦
 : Press to return to the beginning of the current track. Press repeatedly to return to the beginning of previous tracks.
 : Press to advance to the beginning of the next track. Press repeatedly to advance to the beginning of following tracks.
- ⑧ **+10**
Use when selecting track numbers higher than 10 or 100.
For example (in case of MJ-D707 (PIONEER)),
1) To select track 15, press :
+10 → 1 → 5

2) To select track 115, press :
+10 → +10 → 1 → 1 → 5

To start recording

Press both ② and ④ simultaneously.

Cassette deck operations



Before performing these operations, press the MD/TAPE (MULTI CONTROL) button to switch the remote to the MD/TAPE operation mode.

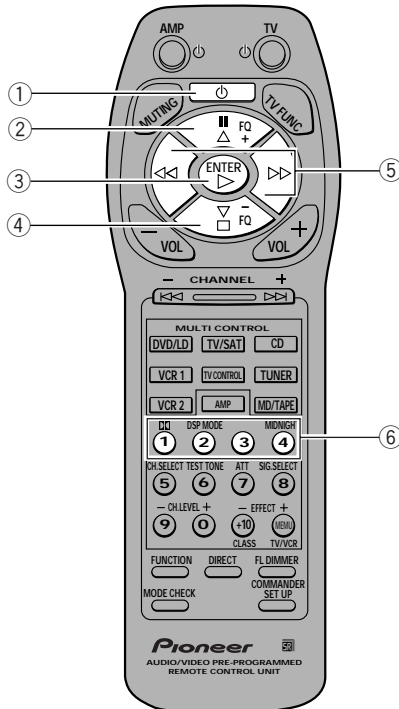

- ① Press to switch the cassette deck on or off (not possible with all models).
- ② Press to pause playback or recording.
- ③ Press to start playback.
- ④ Press to stop playback or recording.
- ⑤
 - : Press to rewind the tape. Hold down during playback for fast reverse playback (not possible with all models).
 - : Press to fast forward the tape. Hold down during playback for fast forward playback (not possible with all models).
- ⑥ **Number buttons**
 - Use to operate deck 1 of a double cassette deck (not possible with all cassette decks).
 - 1 button** () Press to rewind the tape. Hold down during playback for fast reverse playback (not possible with all models).
 - 2 button** () Press to stop playback or recording.
 - 3 button** () Press to start playback.
 - 4 button** () Press to fast forward the tape. Hold down during playback for fast forward playback.

To start recording

Press both ② and ④ simultaneously.
You cannot record on deck 1 of a double cassette deck.

VCR operations



Before performing these operations, press the VCR 1 or VCR 2 (MULTI CONTROL) button to switch the remote to the VCR operation mode.

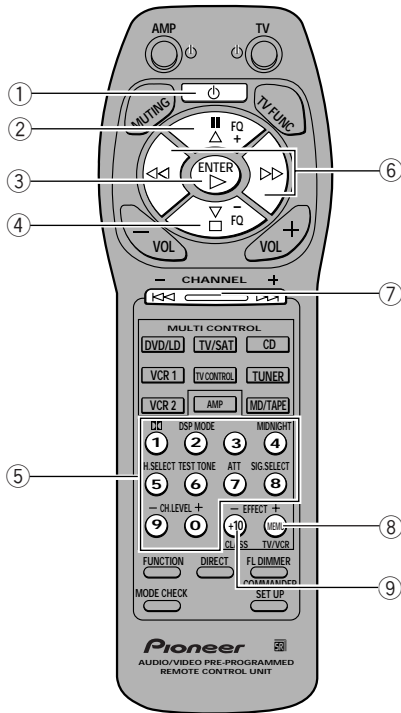

- ① Press to switch the VCR 1 or VCR 2 on or off (not possible with all models).
- ② Press to pause playback or recording.
- ③ Press to start playback.
- ④ Press to stop playback or recording.
- ⑤ **Number buttons**
Use to select a specific channel on the VCR's TV tuner.
- ⑥
 : Press to rewind the tape. Hold down during playback for fast reverse playback (not possible with all models).
 : Press to fast forward the tape. Hold down during playback for fast forward playback (not possible with all models).
- ⑦ **CHANNEL (-/+)**
Use to change the channel of the VCR's TV tuner.
- ⑧ **TV/VCR**
Use to switch the VCR's antenna output between TV and VCR.
- ⑨ **+10 (ENTER)**
Use to select the channel specified with the number buttons (not all models require this step).

To start recording

Press both ② and ④ simultaneously.

Background Control of Other Components

The following steps show you how to control one component while listening to another. This may be useful if you want to rewind a tape while listening to CD, etc.

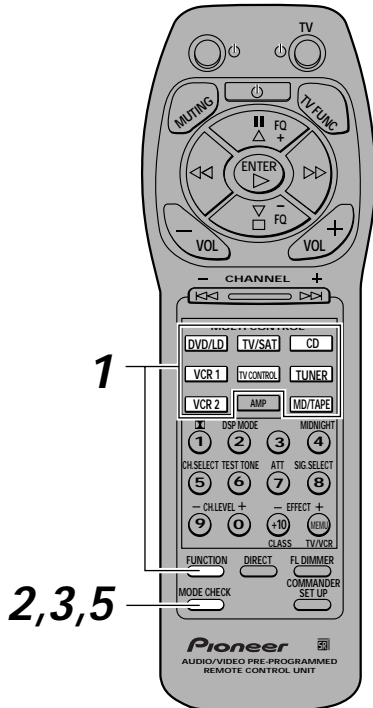

1 Select a component, then start playback.

For example:

Press FUNCTION to select the CD player, then press the CD button, and start playing a CD. (You should hear the sound of the CD playing back.)

2 Press MODE CHECK to display the current operation mode.

The corresponding MULTI CONTROL button lights up.

For example:

The CD button should light up to indicate that the remote is set to operate the CD player.

3 Press MODE CHECK repeatedly to select another operation mode.

Each time you press MODE CHECK, the next MULTI CONTROL button should light, enabling you to operate the selected device.

For example:

Press repeatedly to light the MD/TAPE button. The amplifier function remains set to CD (and you should still hear the CD player), but the remote control is now set to operate the tape deck.

4 Perform the desired operation(s).

The remote control remains in the selected operation mode, so you may perform as many operations as necessary.

For example :

Press ◀◀ to rewind the tape.

5 Press MODE CHECK repeatedly to switch back to the original operation mode.

You can also switch back to the original operation mode by pressing the corresponding MULTI CONTROL button.

For example :

Press MODE CHECK repeatedly to light the CD button, or press the CD button.

Dolby Digital

Dolby Digital is a compression format which records the sound of 6 channels of the theater surround system (Dolby Digital) on the movie film digital track. Of the 6 channels, the sub woofer channel is intended for bass only, and because the frequency range is smaller than the main channel, it is expressed as 5.1 channel.

Dolby Digital is the name of the Dolby surround multi-channel digital system that was developed after the Dolby Surround System and Dolby Pro Logic Surround System.

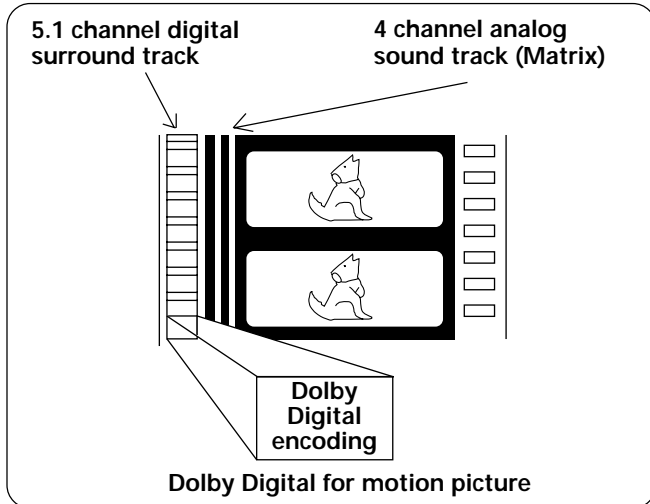

The number of movies made using Dolby Digital since 1992 has exceeded 300 and continues to increase. For compact disc players and laser disc digital sounds, 16 bits are used to sample the original analog audio waveform and sampling is carried out 44,100 times every second. However because an enormous amount of recording signal data is required for the multi channel system with this method, AC-3 is used to compress the data.

In reproducing audio signals, the smaller the bit number used, the lower the sound quality. With AC-3, drop in auditory sound quality is prevented by using masking technology and digital filtering technology based on the human auditory characteristics.

Laser disc format

Laser discs are now available on the market in large numbers. This means that the recording of different format audio signals on the laser disc raises the important question of compatibility with existing laser discs. Dolby Digital tracks on Laser Discs record signals using the space of one analog audio channel so it will maintain compatibility with existing discs and players. As shown in the following figure, the digital audio sounds of Dolby Digital discs can be played back as currently done. Analog sounds are played back by using the other channel without the Dolby Digital signals for monaural audio signals.

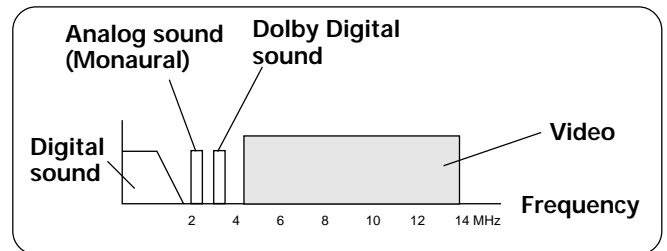

Comparison with Dolby Pro Logic Surround

Dolby Digital is also known as the 5.1 channel system. It is equipped with 5 channels (front left, front right, center, surround left, surround right) in the frequency range from 20 Hz to 20 kHz and an independent Low Frequency Effect (LEF) channel. The sub woofer channel is also called Low Frequency Effect (LFE).

The subwoofer channel can be used as desired to enjoy strong bass sounds.

The following table shows the comparison with Dolby Pro Logic Surround effects.

	Dolby Digital	Dolby Pro Logic Surround
No. of recorded channels	5.1 channels (Max.)	2 channels
No. of playback channels	5.1 channels (Max.)	4 channels
Playback channel structure	Front Left, Front Right, Center, Surround Left, Surround Right, Sub Woofer	Front Left, Front Right, Center, Surround
Sound processing	Digital discrete processing	Analog matrix processing
Rear (Surround) high frequency playback limit	20,000 Hz	7,000 Hz
Other	<ul style="list-style-type: none"> • 5.1 completely independent channels • High dynamic range • Stable position, high phase characteristics, and advanced surround effects reproduction • High efficiency (Compression rate of about one-tenth) 	

Troubleshooting

Incorrect operations are often mistaken for trouble and malfunctions. If you think that there is something wrong with this component, check the points below. Sometimes the trouble may lie in another component. Investigate the other components and electrical appliances being used. If the trouble cannot be rectified even after exercising the checks listed below, ask your nearest PIONEER authorized service center or your dealer to carry out repair work.

Symptom	Cause	Remedy
The power does not turn ON.	<ul style="list-style-type: none"> The power plug is disconnected. The protection circuit may have been activated. 	<ul style="list-style-type: none"> Connect the power plug to the wall outlet. Disconnect the power plug from the outlet, and insert again.
The unit does not respond when the buttons are pressed.	<ul style="list-style-type: none"> Static electricity caused by dry air. 	<ul style="list-style-type: none"> Disconnect the power plug from the wall outlet, and insert again.
No sound is output when a function is selected.	<ul style="list-style-type: none"> Improper connections. Sound is muted. The volume is turned down. Speakers are turned OFF. 	<ul style="list-style-type: none"> Make sure the component is connected correctly (refer to pages 7 to 12). Press MUTING on the remote control. Adjust MASTER VOLUME. Press SPEAKERSto select the speakers you connected.
No image is output when a function is selected.	<ul style="list-style-type: none"> Improper connections. The input source is not properly selected. 	<ul style="list-style-type: none"> Make sure the component is connected correctly (refer to pages 8, 10). Press the correct function button.
No sound from surround or center speakers.	<ul style="list-style-type: none"> Speaker settings are incorrect. The rear and/or center levels are turned down. The surround and/or center speakers are disconnected. 	<ul style="list-style-type: none"> Refer to "SPEAKER setting mode" on page 15 to check the speaker settings. Refer to "Setting the volume level of each channel" on page 19 to check the speaker levels. Connect the speakers (refer to page 10, 11).
Sound is produced from other components, but not from LD or DVD player.	<ul style="list-style-type: none"> SIGNAL SELECT is set incorrectly. The digital inputs are assigned incorrectly, or not at all. 	<ul style="list-style-type: none"> Set SIGNAL SELECT to "DIGITAL" or "ANALOG" according to the type of connections made. (refer to page 27). Set the digital input settings correctly (refer to page 14, 18).
Cannot be remote controlled.	<ul style="list-style-type: none"> The remote control batteries have worn out. Too far away or bad angle of operation. There is an obstacle between the amplifier and the remote control. Strong light such as fluorescent light is shining onto the unit's remote control signal light-receiving window. A cord is connected to the CONTROL IN terminal on this unit. 	<ul style="list-style-type: none"> Replace the batteries (refer to page 5). Operate within 7 m (23 feet), 30° of the remote sensor on the front panel (refer to page 6). Remove the obstacle or operate from another position. Avoid exposing the remote sensor on the front panel to direct light. Connect cord to the correct jack.
The display is dark.	<ul style="list-style-type: none"> The FL DIMMER button is pushed. 	<ul style="list-style-type: none"> Press FL DIMMER on the remote control repeatedly to return to the default.

If the unit does not operate normally due to external effects such as static electricity

Disconnect the power plug from the outlet and insert again to return to normal operating conditions.

Preset Code List

Device	Manufacturer	Manufacturer Code	Device	Manufacturer	Manufacturer Code
DVD	TOSHIBA	001	VCR	DE GRAAF	406
	SONY	002		DECCA	414,419
	PANASONIC	003		DUAL	417
	JVC	004		DUMONT	410,414,419
	SAMSUNG	005		ELCATECH	425
	SHARP	006		FIDELITY	419
	AKAI	007		FINLANDIA	410,414
	RCA	009		FINLUX	406,410,414,419
	PIONEER	000, 003		FIRSTLINE	405,409,411,424,425
LD	SONY	101,103		FISHER	410
	DENON	106		FRONTECH	423
	HITACHI	105		FUNAI	419
	PHILIPS	104		GBC	414
	RADIOLA	104		GENERAL	423
	TELEFUNKEN	100		GOLDSTAR	411
	PIONEER	100		GOODMANS	411,418,419,423,425
SAT	PIONEER	200		GRAETZ	410,417
VCR	PHILIPS	414,428		GRANADA	410,414
	PANASONIC	403,408		GRANDIENTE	430
	THOMSON	417,420,428		GRANDIN	411,419,425
	SONY	416,417		HCM	425,426
	JVC	407,417,428		HINARI	412,413,425,426
	GRUNDIG	408,414,419,425,426,427		HYPSON	425
	AKAI	401,417		IMPERIAL	419
	HITACHI	406,417,419		INTERFUNK	414
	TOSHIBA	405,409,414,417,428		ITT	401,410,417,428
	MITSUBISHI	407,409,414		ITV	411,418
	SHARP	402		KAISUI	425
	ORION	412,413,424		KENDO	401,424
	SANYO	410		KORPEL	425
	FERGUSON	417,420,421		LEYCO	425
	BLAUPUNKT	403,408,417,427		LOEWE	411,414
	NOKIA	401,410,417		LUXOR	401,409,410
	SELECO	417	M-ELECTRONIC	419	
	AIWA	413,419	MANESTH	405,425	
	AKIBA	425	MARANTZ	414	
	ALBA	413,415,418,423,424	MATSUI	412,413,424	
	AMBASSADOR	423	MEMOREX	410,411,419	
	AMSTRAD	419	MEMPHIS	425	
	ANITECH	425	METZ	403,427	
	ASA	411,414	MINERVA	427	
	BAIRD	410,417,419,421	MULTITECH	419,425	
	BASIC LINE	418,423,425	MURPHY	419	
	BRANDT	420,422	NBC	407,417	
	BRANDT ELECTRONIQUE	417	NECKERMANN	414	
	BUSH	413,415,418,424,425	NESCO	425	
	CATRON	423	NORDMENDE	417,428	
	CGB	419	OCEANIC	417,419	
	CIMLINE	425	OSAKI	411,419,425	
	CLATRONIC	423	OTTO VERSAND	414	
	CONDOR	423	PALLADIUM	411,417,425	
	CROWN	418,423,425	PATHE MARCONI	417	
	DAEWOO	418,423	PENTAX	406	
	DANSAI	425	PERDIO	419	
				PHONOLA	414

Device	Manufacturer	Manufacturer Code	Device	Manufacturer	Manufacturer Code
VCR	PORTLAND	423	CD	AKAI	308
	PROLINE	419,426		ARCAM	312
	PYE	414		ASUKA	313
	QUELLE	414		AUDIO TON	312
	RADIOLA	414		BUSH	305
	REX	417,428		CALIFORNIA	304
	ROADSTAR	411,418,425		AUDIO LAB	
	SABA	417,420,428		CYRUS	312
	SAISHO	412,424		DENON	309
	SALORA	401,409		DUAL	313,319
	SANSUI	407,417		FISHER	317
	SBR	414		GOLDSTAR	302
	SCHAUB LORENZ	417,419		GRUNDIG	312
	SCHNEIDER	414,419,425		HITACHI	307
	SEI	414		INTERSOUND	313
	SENTRA	423		JVC	303
	SHINTOM	425		KENWOOD	310,311
	SIEMENS	410,411,427		KODAK	322
	SINGER	405		LINN	312
	SINUDYNE	414		LUXMAN	318
	SOLAVOX	423		M ELECTRONIC	323
	SUNSTAR	419		MARANTZ	304,312
	SUNTRONIC	419		MATSUI	312
	TASHIKO	419		MCS	304
	TATUNG	414,417,419		MEMOREX	300
	TEC	423		MERIDIAN	312
	TELEAVIA	417		MITSUBISHI	308
	TELEFUNKEN	417,420,422,428		NAD	316
	TENOSAL	425		NAIM	312
	TENSAI	419		ONKYO	320
	THORN	410,417		PANASONIC	304
UNIVERSUM	401,411,414,419,427	PHILIPS	312,322		
YAMISHI	425	QUAD	312		
YOKAN	425	QUASER	304		
YOKO	423	ROADSTAR	323		
PIONEER	400,404,407,414	ROTEL	312		
TAPE	AKAI	823	TV	SABA	319
	ARCAM	810		SANYO	317
	DENON	810,821		SHARP	321
	FISHER	813		SONY	301,316
	GRUNDIG	815		TECHNICS	304,306
	JVC	802		TELEFUNKEN	319
	KENWOOD	804,807,816		THOMSON	319
	LUXMAN	805		UNIVERSUM	312
	MARNATZ	815		YAMAHA	314,315
	MEMOREX	819		PIONEER	300,325
	MITSUBISHI	823		PHILIPS	601,607,610,636
	NAKAMICHI	806		SONY	604
	ONKYO	808,812		GRUNDIG	601,632
	PHILIPS	815		PANASONIC	601,608,620,622
	SANSUI	818		TOSHIBA	605,632
	SHERWOOD	809		TELEFUNKEN	612,614,631
	SONY	801,817		SHARP	602
	TANDBERG	814		SAMSUNG	607,615,623,625
	TECHNICS	803		HITACHI	601,606,610,612,620,621,633,637
	TOSHIBA	820,822		SABA	601,612,620,630
	YAMAHA	811,816		BRANDT	612
PIONEER	800,819	SANYO	611,624,627		

Additional Information

Device	Manufacturer	Manufacturer Code	Device	Manufacturer	Manufacturer Code
TV	THOMSON	612,630,631	TV	FIRSTLINE	617,623
	FERGUSON	607,612,630		FISHER	603,611,615,624
	NOKIA	603,620,631		FORMENTI	603,607,620
	mitsubishi	601,609		FRONTECH	601,620,625
	SCHNEIDER	607,619,626		FRONTECH/ PROTECH	603
	GOLDSTAR	607,629		FUJITSU	627
	BLAUPUNKT	601		FUNAI	617,625
	NORDMENDE	603,612,630,631		GBC	603,620
	RADIOLA	607		GEC	607,610,627
	JVC	613		GELOSO	603,623
	DAEWOO	607,623,636		GENEXXA	601,619
	ORION	603,607,616,617		GOODMANS	607,616,626,627,636
	SIEMENS	601		GORENJE	615
	ACURA	623		GPM	619
	ADMIRAL	601		GRAETZ	601,620
	AKAI	603,611,620		GRANADA	607,611,620,621,627
	AKURA	619		GRANDIENTE	639
	ALBA	607,616,619,623		GRANDIN	618
	AMSTRAD	620,623,626		HANSEATIC	607,620
	ANITECH	623		HCM	618,623
	ASA	624		HINARI	607,619,623
	ASUKA	619		HISAWA	618
	AUDIOGONIC	607,612		HUANYU	636
	BASIC LINE	619,623		HYPSON	607,618,625
	BAUR	601,607,620		ICE	625,626
	BEKO	615		IMPERIAL	615,620
	BEON	607		INDIANA	607
	BLUE SKY	619		INGELEN	601
	BLUE STAR	618		INTERFUNK	601,603,607,620
	BPL	618		INTERVISION	625,628
	BTC	619		ISUKAI	619
	BUSH	607,619,620,623,626,636		ITC	620
	CASCADE	623		ITT	601,603,620
	CATHAY	607		JEC	605
	CENTURION	607		KAISUI	618,619,623
	CGB	620		KAPSCH	601
	CIMLINE	623		KENDO	620
	CLARIVOX	607		KENNEDY	603,620
	CLATRONIC	615		KORPEL	607
	CONDOR	615		KOYODA	623
	CONTEC	623		LEYCO	607,617,625,627
	CROSLEY	603		LIESENK&TTER	607
	CROWN	615,623		LUXOR	603,620,621
CRYSTAL	620	M ELECTRONIC	601,623,624,633,635,636		
CYBERTRON	619	M-ELECTRONIC	607,612,630		
DAINICHI	619	MAGNADYNE	603,628		
DANSAI	607	MAGNAFON	628		
DAYTON	623	MANESTH	616,625		
DECCA	607,627	MARANTZ	607		
DIXI	607,623	MARK	607		
DUMONT	632	MATSUI	607,616,617,620,623,626,627		
ELIN	607	MCMICHAEL	610		
ELITE	619	MEDIATOR	607		
ELTA	623	MEMOREX	623		
EMERSON	620	METZ	601		
ERRES	607	MINERVA	601,632		
FINLANDIA	611,621,635	MULTITECH	623,628		
FINLUX	603,607,624,627,632,633,635	NECKERMANN	601,607		

Device	Manufacturer	Manufacturer Code	Device	Manufacturer	Manufacturer Code	
TV	NEI	607,620	TV	SONOLOR	601,611	
	NIKKAI	605,607,619,625,627		SONTEC	607	
	NOBLIKO	628		SOUNDWAVE	607	
	OCEANIC	601,603,620		STANDARD	619,623	
	OSAKI	619,625,627		STERN	601	
	OSO	619		SUSUMU	619	
	OSUME	627		SYSLINE	607	
	OTTO VERSAND	601,603,607,620		TANDY	601,619,627	
	PALLADIUM	615		TASHIKO	610	
	PANAMA	625		TATUNG	607,627	
	PATHO CINEMA	620		TEC	620	
	PAUSA	623		TELEAVIA	612	
	PHILCO	603,620		TELETECH	623	
	PHOENIX	603		TENSAI	617,619	
	PHONOLA	607		THORN	601,607,620,624,627	
	PROFEX	620,623		TOMASHI	618	
	PROTECH	607,620,623,625,628		TOWADA	620	
	QUELLE	601,603,607,620,624,632		ULTRAVOX	603,620,628	
	R-LINE	607		UNIVERSUM	601,607,615,620,624,625,633,635	
	RBM	632		VESTEL	607	
	REDIFFUSION	603,620		VOXSON	601	
	REX	601,625		WALTHAM	621	
	ROADSTAR	619,623,625		WATSON	607	
	SAISHO	616,623,625		WATT RADIO	603,620,628	
	SALORA	601,603,620,621		WHITE	607	
	SAMBERS	628		WESTINGHOUSE		
	SBR	607,610		YOKO	607,620,625	
	SCHAUB	620		PIONEER	600,601,603,607,612,620,630	
	LORENZ					
	SEG	620,625		MD	SONY	901
	SEI	603,617,628			KENWOOD	903
	SELECO	601,620			SHARP	902
	SIAREM	603,628			TEAC	904
SINUDYNE	603,616,617,628		ONKYO	905		
SKANTIC	621		DENON	906		
SOLAVOX	601		PIONEER	900,902		
SONOKO	607,623	TUNER	PIONEER	500		

Specifications

Continuous Power Output

(DIN, 1 kHz, T.H.D. 1%, 8 Ω)

STEREO	Front	100 W + 100 W
SURROUND	Front	60 W + 60 W
	Center	60 W
	Rear	60 W

Input (Sensitivity/Impedance)

VCR, DVD/LD, TV/SAT, VIDEO, CD, TUNER, AUX	MD/TAPE,	200 mV/47 kΩ
--	----------------	--------------

Frequency Response

VCR, DVD/LD, TV/SAT, VIDEO, CD, TUNER, AUX	MD/TAPE,	5 Hz to 100,000 Hz $\begin{matrix} +0 \\ -3 \end{matrix}$ dB
--	----------------	--

Output (Level/Impedance)

VCR REC, MD/TAPE REC	200 mV/2.2 kΩ
----------------------	-------	---------------

Tone Control

BASS	± 6 dB (100 Hz)
TREBLE	± 6 dB (10 kHz)
LOUDNESS	+9 dB/+7 dB (100 Hz/10 kHz)

Signal-to-Noise Ratio [DIN (Rated power output/50 mW)]*

VCR, DVD/LD, TV/SAT, VIDEO, CD, TUNER, AUX	MD/TAPE,	82 dB/62 dB
--	----------------	-------------

VIDEO Section

Input (Sensitivity/Impedance)

VCR, DVD/LD, TV/SAT, VIDEO	1 Vp-p/75 Ω
----------------------------	-------	-------------

Output (Level/Impedance)

VCR, MONITOR	1 Vp-p/75 Ω
--------------	-------	-------------

Frequency Response

VCR, MONITOR	5 Hz to 7 MHz $\begin{matrix} +0 \\ -3 \end{matrix}$ dB
--------------	-------	---

Signal-to-Noise Ratio

.....	55 dB
-------	-------	-------

Cross Talk

.....	55 dB
-------	-------	-------

* *Direct: ON*

** *Measured by Audio Spectrum Analyzer.*

Miscellaneous

Power Requirement	AC 220-230 V, 50/60 Hz
Power Consumption	220 W
Power Consumption in Standby mode	1 W
Dimensions	420 (W) × 158 (H) × 401 (D) mm
Weight (without package)	9.8 kg

Furnished Parts

Dry Cell Batteries (SIZE "AA" (IEC LR6))	2
Remote Control Unit	1
Operating Instructions	1

NOTE:

Specifications and the design are subject to possible modifications without notice, due to improvements.

Published by Pioneer Electronic Corporation.
Copyright © 1999 Pioneer Electronic Corporation.
All rights reserved.

PIONEER ELECTRONIC CORPORATION

4-1, Meguro 1-Chome, Meguro-ku, Tokyo 153-8654, Japan

PIONEER ELECTRONICS [USA] INC. P.O. BOX 1540, Long Beach, California 90801-1540

PIONEER ELECTRONICS OF CANADA, INC. 300 Allstate Parkway, Markham, Ontario L3R OP2, Canada

PIONEER ELECTRONIC [EUROPE] N.V. Haven 1087, Keetberglaan 1, 9120 Melsele, Belgium TEL: 03/570.05.11

PIONEER ELECTRONICS AUSTRALIA PTY. LTD. 178-184 Boundary Road, Braeside, Victoria 3195, Australia, TEL: 03-9586-6300

PIONEER ELECTRONICS DE MEXICO S.A. DE C.V. San Lorenzo Num 1009 3er piso Desp. 302 Col. Del Valle, Mexico D.F. C.P. 03100 TEL: 5-688-52-90