

**PARABODY**

*Serious Steel*

965101

**FLAT & INCLINE BENCH  
ASSEMBLY INSTRUCTIONS**

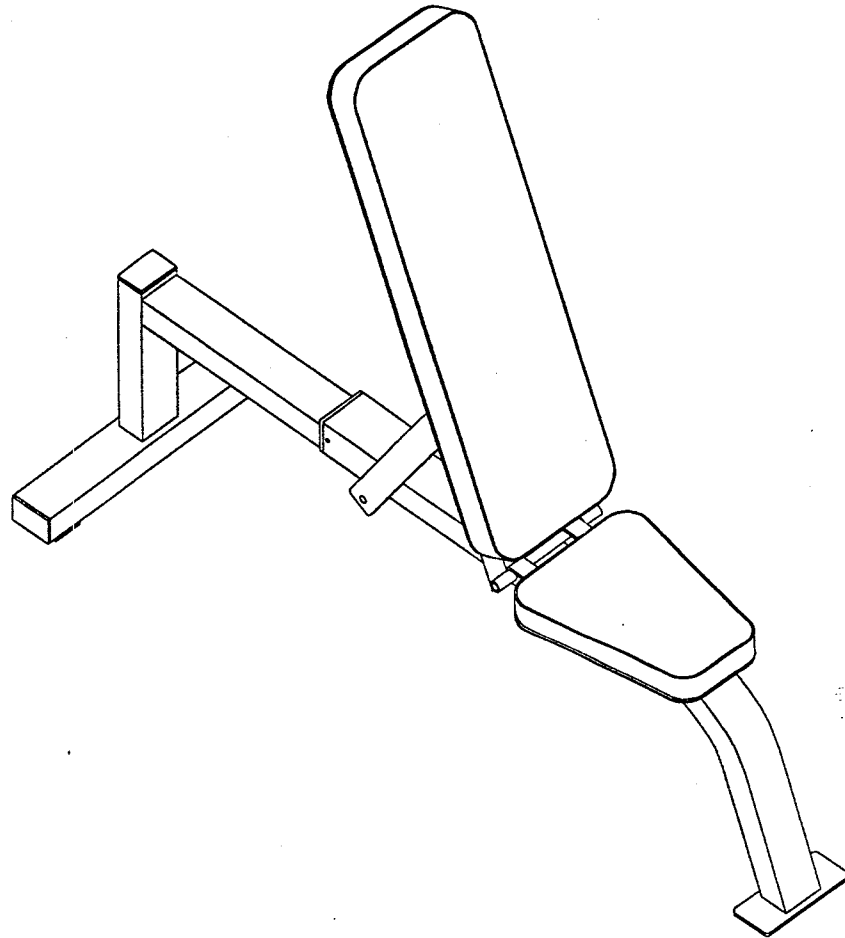

ParaBody, Incorporated  
14150 Sunfish Lake Boulevard  
Ramsey, MN 55303  
1-800-328-9714

# 965101 FLAT & INCLINE BENCH ASSEMBLY PARTS LIST

SORT AND COUNT ALL PARTS BEFORE BEGINNING ASSEMBLY

## HARDWARE:

ITEM	NAME/DESCRIPTION	QTY
1.	1/2 X 9-1/2 IN BOLT .....	1
2.	1/2 X 6-1/2 IN BOLT .....	1
3.	1/2 X 3 IN BOLT .....	2
4.	1/2 X 1-1/4 IN BOLT .....	2
5.	3/8 X 1 IN BOLT .....	6
6.	1/2 IN WASHER .....	6
7.	3/8 IN WASHER .....	6
8.	1/2 IN LOCK NUT .....	3
9.	1/2 IN LOW HEIGHT LOCK NUT .....	3
10.	HINGE TAB .....	2
11.	6-1/8 X 3-7/8 IN U-PIN .....	1
12.	1/2 ID X 5/8 IN SPACER .....	1
13.	SPRING PIN ASSEMBLY .....	1
14.	1/2 IN ID CAPNUT .....	1
15.	3 X 2 IN INSERT GUIDE .....	2
16.	3 X 2 IN END CAP .....	3
17.	7/16 ID X 4 IN VINYL CAP .....	1

## WELDMENTS/PARTS:

ITEM	NAME/DESCRIPTION	QTY
1.	REAR UPRIGHT WELDMENT ..... (6651703) .....	1
2.	BENCH FRAME WELDMENT ..... (6652103) .....	1
3.	ADJ SLEEVE WELDMENT ..... (6652803) .....	1
4.	BACK PAD ANGLE WELDMENT LEFT ..... (6624202) .....	1
5.	BACK PAD ANGLE WELDMENT RIGHT ..... (6624302) .....	1
6.	1/2 X 2 X 15-1/2 IN PLATE ..... (6651602) .....	2
7.	SEAT PAD ..... <del>66353XX</del> (66535XX) .....	1
8.	BACK PAD ..... (66529XX) .....	1

NOTE: BOLT LENGTH IS MEASURED FROM THE UNDERSIDE OF THE HEAD OF THE BOLT.

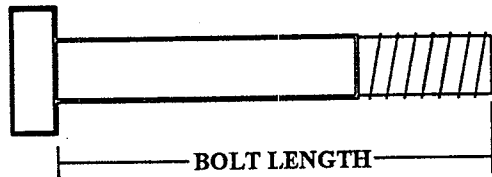

BOLT LENGTH RULER:

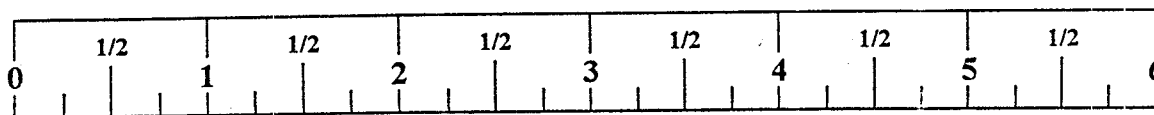

## 965101 FLAT & INCLINE BENCH ASSEMBLY INSTRUCTIONS

### THANK YOU

FOR PURCHASING THE *965101 FLAT & INCLINE BENCH*. PLEASE SAVE THESE ASSEMBLY INSTRUCTIONS FOR YOUR PERSONAL REFERENCE, AND ADDITIONAL SERVICE INFORMATION.

### \*\*\*IMPORTANT\*\*\*

- THE *965101 FLAT & INCLINE BENCH* MUST BE ASSEMBLED ON A FLAT, LEVEL SURFACE TO ASSURE ITS PROPER FUNCTION.
- IF YOU EXPERIENCE ANY PROBLEM WITH THE ASSEMBLY OF THIS PRODUCT, PLEASE CONTACT YOUR DEALER OR YOUR PARABODY CUSTOMER SERVICE REPRESENTATIVE AT: 1-800-328-9714
- **TOOLS REQUIRED:** RATCHET, 3/4 SOCKET and WRENCH, 9/16 SOCKET and WRENCH, and RUBBER MALLET or HAMMER.

1. Slide one (1) 7/16 ID X 4 IN VINYL CAP onto the 6-1/8 X 3-7/8 IN U-PIN and proceed to assemble it to the **BENCH FRAME WELDMENT** as shown on drawing.
2. Insert two (2) 3 X 2 INSERT GUIDES into each end of the **ADJ SLEEVE WELDMENT** as shown on drawing. (NOTE: **MAKE SURE THE INSERT GUIDES SNAP INTO THE HOLES OF THE WELDMENT**). **SECURELY** assemble the **SPRING PIN ASSEMBLY** to the **ADJ SLEEVE WELDMENT** as shown in (DETAIL A).
3. Pull back the **SPRING PIN** on the **ADJ SLEEVE WELDMENT** and slide it over the end of the **BENCH FRAME WELDMENT** as shown on drawing. Slide **WELDMENT** up to the first adjustment hole underneath.
4. Insert three (3) 3 X 2 IN END CAPS into the ends of the **REAR UPRIGHT WELDMENT** as shown on drawing.
5. **SECURELY** assemble the **REAR UPRIGHT WELDMENT** to the **BENCH FRAME WELDMENT** as shown on drawing.
6. Assemble the **LEFT** and **RIGHT BACK PAD ANGLE WELDMENTS**, along with two (2) **HINGE TABS** to the **BENCH FRAME WELDMENT** as shown on drawing. (NOTE: **TIGHTEN CONNECTION ENOUGH TO REMOVE THE PLAY YET ALLOWING THE PARTS TO ROTATE FREELY**).
7. Assemble two (2) 1/2 X 2 X 15-1/2 IN **PLATES** to the inside of the **LEFT** and **RIGHT BACK PAD ANGLE WELDMENTS** as shown on drawing. (NOTE: **TIGHTEN CONNECTION ENOUGH TO REMOVE THE PLAY YET ALLOWING THE PARTS TO ROTATE FREELY**).
8. Rotate the **LEFT** and **RIGHT BACK PAD ANGLE WELDMENTS** up and assemble the 1/2 X 2 X 15-1/2 IN **PLATES** to the **ADJ SLEEVE WELDMENT** as shown on drawing. (NOTE: **DO NOT OVER TIGHTEN THIS CONNECTION**).

## 965101 FLAT & INCLINE BENCH ASSEMBLY INSTRUCTIONS

---

9. **SECURELY** assemble the **BACK PAD** to the **LEFT** and **RIGHT BACK PAD ANGLE WELDMENTS** as shown on drawing.
10. **SECURELY** assemble the **SEAT PAD** to the **HINGE TABS** on the **BENCH FRAME WELDMENT** as shown on drawing.

DASH NO	DESCRIPTION
01	AS SHOWN

REVISIONS				
REV	DESCRIPTION	CHG NO	APP'D	DATE
C	WAS 4-3/8	3001	DLm	11/96

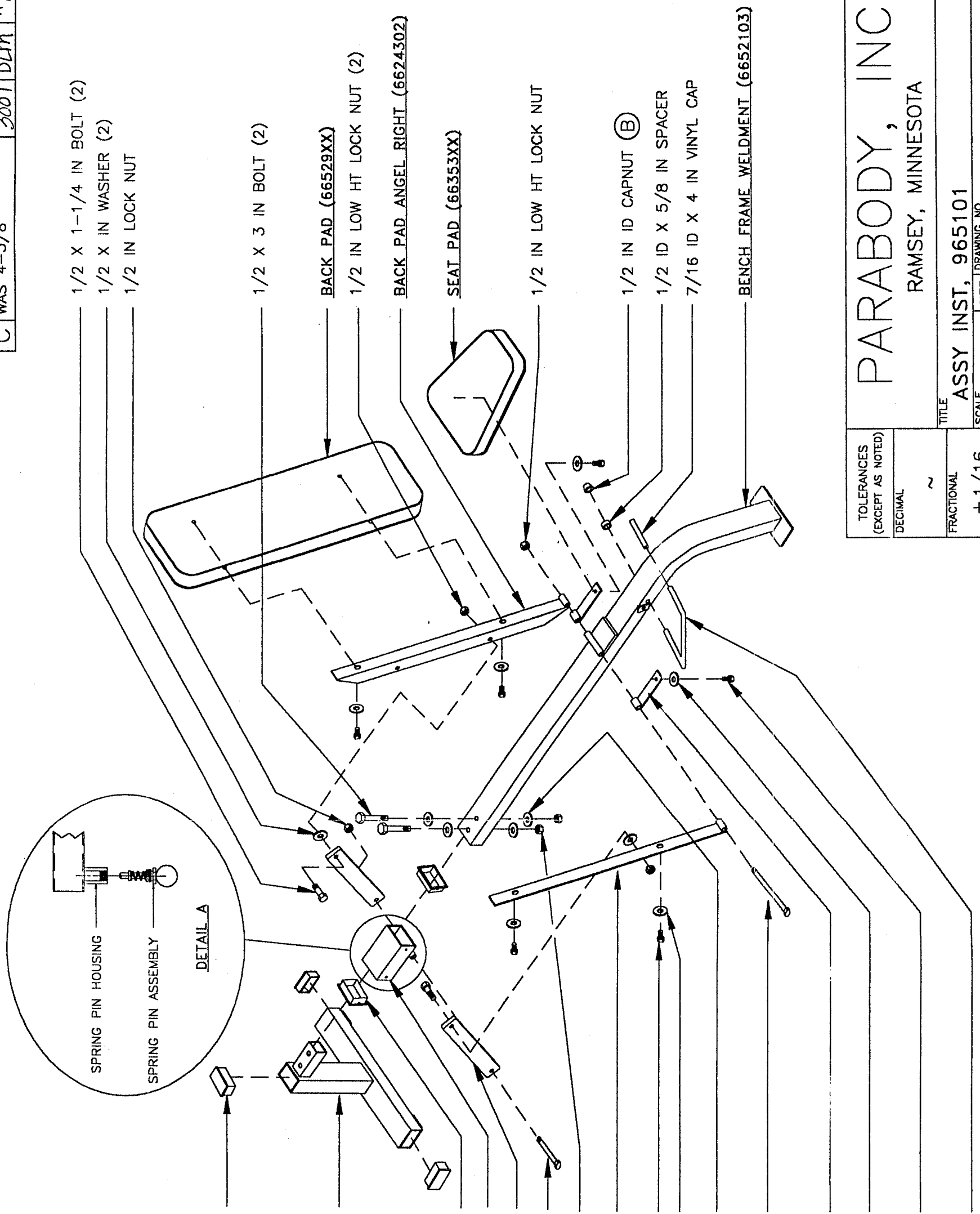

1/2 X 1-1/4 IN BOLT (2)  
 1/2 X IN WASHER (2)  
 1/2 IN LOCK NUT

1/2 X 3 IN BOLT (2)

BACK PAD (66529XX)  
 1/2 IN LOW HT LOCK NUT (2)

BACK PAD ANGLE RIGHT (6624302)

SEAT PAD (66353XX)

1/2 IN LOW HT LOCK NUT

1/2 IN ID CAPNUT (B)

1/2 ID X 5/8 IN SPACER

7/16 ID X 4 IN VINYL CAP

BENCH FRAME WELDMENT (6652103)

3 X 2 END CAP (3)

REAR UPRIGHT WELDMENT (6651703)

3 X 2 IN INSERT GUIDE (2)

ADJ SLEEVE WELDMENT (6652803)

1/2 X 2 X 15-1/2 IN PLATE (6651602)

1/2 X 6-1/2 IN BOLT

1/2 IN LOCK NUT (2)

BACK PAD ANGLE WELDMENT LEFT (6624202)

3/8 X 1 IN BOLT (4)

3/8 IN WASHER (4)

1/2 IN WASHER (4)

1/2 X 9-1/2 IN BOLT

HINGE TAB (2)

3/8 IN WASHER (2)

3/8 X 1 IN BOLT (2)

© 6-1/8 X 3-7/8 U PIN

TOLERANCES (EXCEPT AS NOTED)	DECIMAL	~
FRACTIONAL	± 1/16	
ANGULAR	± 1°	

TITLE		ASSY INST, 965101	
SCALE	1=12	DRAWING NO.	66535
SHEET	1 OF 1	DR	SAL
CHK'D	9/96	APP'D	MGN
PARABODY, INC.		RAMSEY, MINNESOTA	

**965101 FLAT & INCLINE BENCH ASSEMBLY PARTS LIST**

**SORT AND COUNT ALL PARTS BEFORE BEGINNING ASSEMBLY**

**HARDWARE:**

ITEM	NAME/DESCRIPTION	QTY
1.	1/2 X 9-1/2 IN BOLT .....	1
2.	1/2 X 6-1/2 IN BOLT .....	1
3.	1/2 X 3 IN BOLT .....	2
4.	1/2 X 1-1/4 IN BOLT .....	2
5.	3/8 X 1 IN BOLT .....	6
6.	1/2 IN WASHER .....	6
7.	3/8 IN WASHER .....	6
8.	1/2 IN LOCK NUT .....	3
9.	1/2 IN LOW HEIGHT LOCK NUT .....	3
10.	HINGE TAB .....	2
11.	6-1/8 X 3-7/8 IN U-PIN .....	1
12.	1/2 ID X 5/8 IN SPACER .....	1
13.	SPRING PIN ASSEMBLY .....	1
14.	1/2 IN ID CAPNUT .....	1
15.	3 X 2 IN INSERT GUIDE .....	2
16.	3 X 2 IN END CAP .....	3
17.	7/16 ID X 4 IN VINYL CAP .....	1

**WELDMENTS/PARTS:**

ITEM	NAME/DESCRIPTION	QTY
1.	REAR UPRIGHT WELDMENT ..... (6651703) .....	1
2.	BENCH FRAME WELDMENT ..... (6652103) .....	1
3.	ADJ SLEEVE WELDMENT ..... (6652803) .....	1
4.	BACK PAD ANGLE WELDMENT LEFT ..... (6624202) .....	1
5.	BACK PAD ANGLE WELDMENT RIGHT ..... (6624302) .....	1
6.	1/2 X 2 X 15-1/2 IN PLATE ..... (6651602) .....	2
7.	SEAT PAD ..... (66535XX) .....	1
8.	BACK PAD ..... (66529XX) .....	1

**NOTE: BOLT LENGTH IS MEASURED FROM THE UNDERSIDE OF THE HEAD OF THE BOLT.**

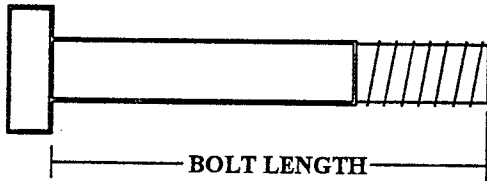

**BOLT LENGTH RULER:**

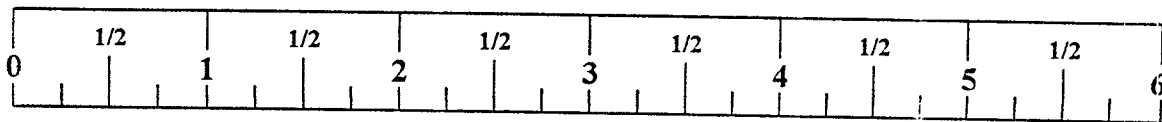

## 965101 FLAT & INCLINE BENCH ASSEMBLY INSTRUCTIONS

### THANK YOU

FOR PURCHASING THE *965101 FLAT & INCLINE BENCH*. PLEASE SAVE THESE ASSEMBLY INSTRUCTIONS FOR YOUR PERSONAL REFERENCE, AND ADDITIONAL SERVICE INFORMATION.

### \*\*\*IMPORTANT\*\*\*

- THE *965101 FLAT & INCLINE BENCH* MUST BE ASSEMBLED ON A FLAT, LEVEL SURFACE TO ASSURE ITS PROPER FUNCTION.
- IF YOU EXPERIENCE ANY PROBLEM WITH THE ASSEMBLY OF THIS PRODUCT, PLEASE CONTACT YOUR DEALER OR YOUR PARABODY CUSTOMER SERVICE REPRESENTATIVE AT: 1-800-328-9714.
- **TOOLS REQUIRED:** PATCHET, 3/4 SOCKET and WRENCH, 9/16 SOCKET and WRENCH, and RUBBER Mallet or HAMMER.

1. Slide one (1) 7/16 ID X 4 IN VINYL CAP onto the 6-1/8 X 3-7/8 IN U-PIN and proceed to assemble it to the **BENCH FRAME WELDMENT** as shown on drawing.
2. Insert two (2) 3 X 2 INSERT GUIDES into each end of the **ADJ SLEEVE WELDMENT** as shown on drawing. (NOTE: **MAKE SURE THE INSERT GUIDES SNAP INTO THE HOLES OF THE WELDMENT**). **SECURELY** assemble the **SPRING PIN ASSEMBLY** to the **ADJ SLEEVE WELDMENT** as shown in (DETAIL A).
3. Pull back the **SPRING PIN** on the **ADJ SLEEVE WELDMENT** and slide it over the end of the **BENCH FRAME WELDMENT** as shown on drawing. Slide **WELDMENT** up to the first adjustment hole underneath.
4. Insert three (3) 3 X 2 IN END CAPS into the ends of the **REAR UPRIGHT WELDMENT** as shown on drawing.
5. **SECURELY** assemble the **REAR UPRIGHT WELDMENT** to the **BENCH FRAME WELDMENT** as shown on drawing.
6. Assemble the **LEFT** and **RIGHT BACK PAD ANGLE WELDMENTS**, along with two (2) **HINGE TABS** to the **BENCH FRAME WELDMENT** as shown on drawing. (NOTE: **TIGHTEN CONNECTION ENOUGH TO REMOVE THE PLAY YET ALLOWING THE PARTS TO ROTATE FREELY**).
7. Assemble two (2) 1/2 X 2 X 15-1/2 IN **PLATES** to the inside of the **LEFT** and **RIGHT BACK PAD ANGLE WELDMENTS** as shown on drawing. (NOTE: **TIGHTEN CONNECTION ENOUGH TO REMOVE THE PLAY YET ALLOWING THE PARTS TO ROTATE FREELY**).
8. Rotate the **LEFT** and **RIGHT BACK PAD ANGLE WELDMENTS** up and assemble the 1/2 X 2 X 15-1/2 IN **PLATES** to the **ADJ SLEEVE WELDMENT** as shown on drawing. (NOTE: **DO NOT OVER TIGHTEN THIS CONNECTION**).

## **965101 FLAT & INCLINE BENCH ASSEMBLY INSTRUCTIONS**

---

9. **SECURELY** assemble the **BACK PAD** to the **LEFT** and **RIGHT BACK PAD ANGLE WELDMENTS** as shown on drawing.
10. **SECURELY** assemble the **SEAT PAD** to the **HINGE TABS** on the **BENCH FRAME WELDMENT** as shown on drawing.



DASH NO  
01 AS SHOWN

REVISIONS			
REV	DESCRIPTION	CHG NO	APP'D
C	WAS 4-3/8	3001	DLM
			DATE
			11/96

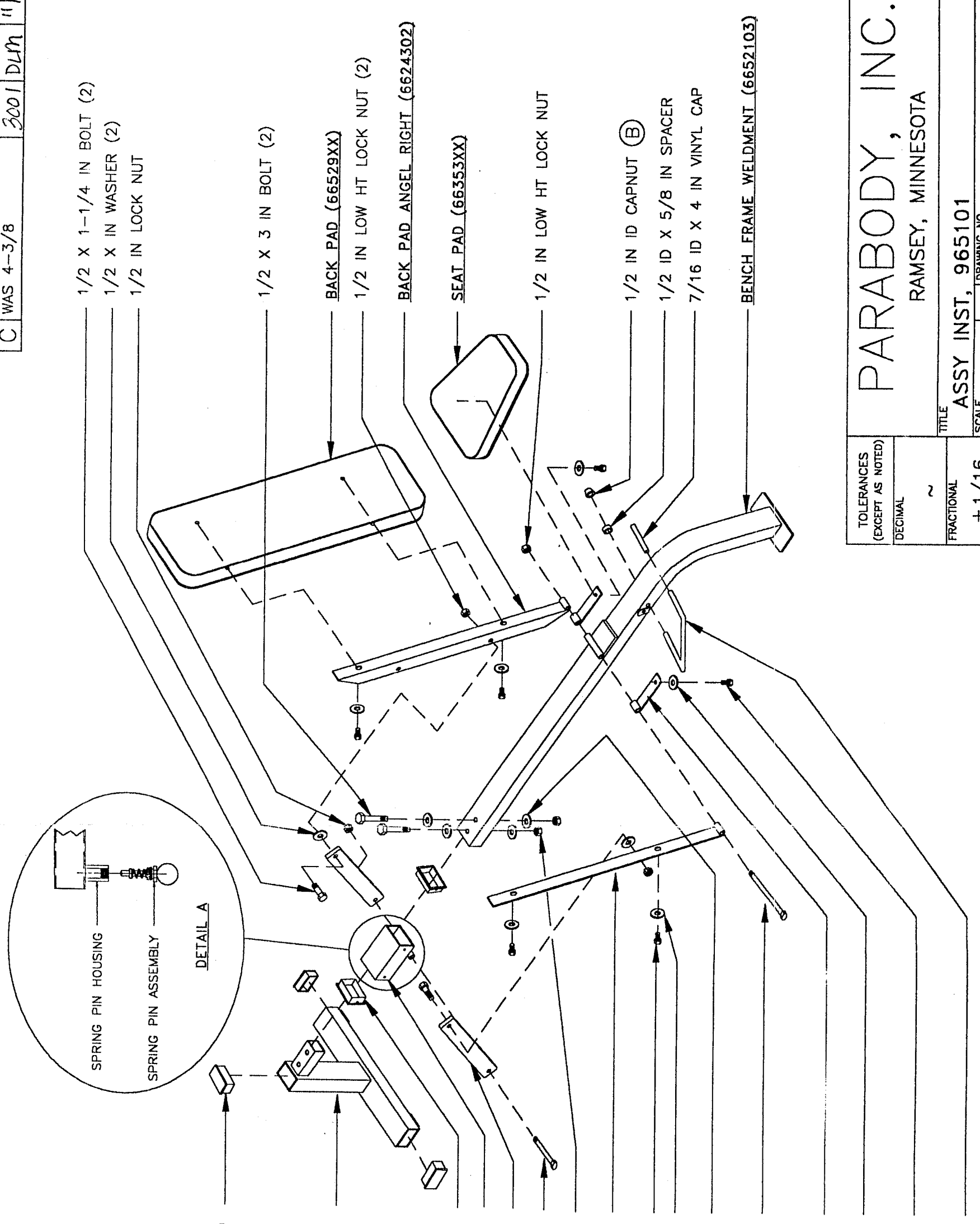

1/2 X 1-1/4 IN BOLT (2)  
1/2 X IN WASHER (2)  
1/2 IN LOCK NUT

1/2 X 3 IN BOLT (2)

BACK PAD (66529XX)  
1/2 IN LOW HT LOCK NUT (2)

BACK PAD ANGLE RIGHT (6624302)

SEAT PAD (66353XX)

1/2 IN LOW HT LOCK NUT

1/2 IN ID CAPNUT (B)

1/2 ID X 5/8 IN SPACER

7/16 ID X 4 IN VINYL CAP

BENCH FRAME WELDMENT (6652103)

3 X 2 END CAP (3)

REAR UPRIGHT WELDMENT (6651703)

3 X 2 IN INSERT GUIDE (2)

ADJ SLEEVE WELDMENT (6652803)

1/2 X 2 X 15-1/2 IN PLATE (6651602)

1/2 X 6-1/2 IN BOLT

1/2 IN LOCK NUT (2)

BACK PAD ANGLE WELDMENT LEFT (6624202)

3/8 X 1 IN BOLT (4)

3/8 IN WASHER (4)

1/2 IN WASHER (4)

1/2 X 9-1/2 IN BOLT

HINGE TAB (2)

3/8 IN WASHER (2)

3/8 X 1 IN BOLT (2)

© 6-1/8 X 3-7/8 U PIN

TOLERANCES (EXCEPT AS NOTED)	
DECIMAL	~
FRACTIONAL	± 1/16
ANGULAR	± 1°

PARABODY, INC. RAMSEY, MINNESOTA	
TITLE ASSY INST, 965101	
SCALE 1=12	SIZE DRAWING NO.
SHEET 1 OF 1	B
DR	SAL
CHK'D	9/96
APP'D	MGN
	9/96
66535	