

ROBERTS

Sound for Generations

SRCD970

Stereo CD Radio
Cassette Recorder

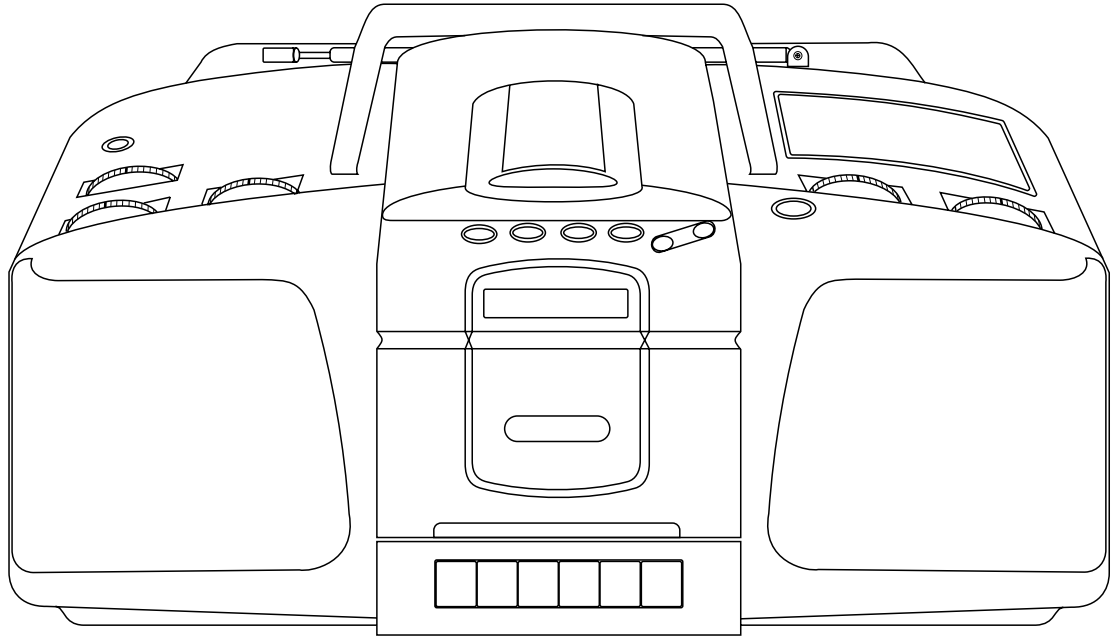

Please read this manual before use

Controls

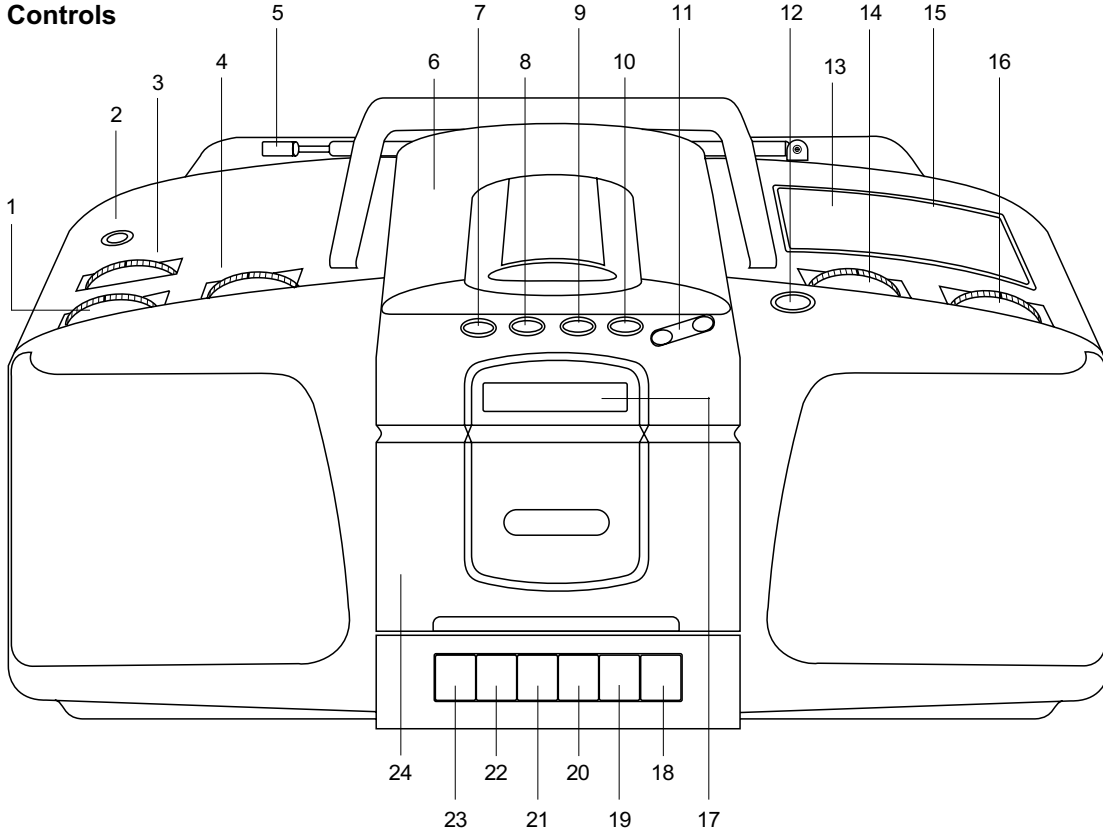

1. Tone control
2. Headphone socket
3. Tape/Radio/CD Function switch
4. Volume control
5. Telescopic aerial
6. CD lid
7. CD repeat button
8. CD stop button
9. CD play/pause button
10. CD mix button
11. CD track F Skip and B Skip buttons
12. CD compartment open button
13. FM stereo indicator
14. Waveband switch
15. Tuning scale
16. Tuning control
17. Liquid crystal display
18. Pause button
19. Stop/eject button
20. Fast forward button
21. Rewind button
22. Play button
23. Record button
24. Cassette door

General

Do not allow this unit to be exposed to water or steam. Do not leave the unit where excessive heat could cause damage. It is recommended that the FM band be used wherever possible as better results in terms of quality and freedom from interference will usually be obtained than on the MW band.

Mains supply

The SRCD970 will operate from a supply of AC 230 volts, 50Hz \sim only.

For your convenience this product is supplied with a plug which is fitted with a fuse of the appropriate rating. If the plug supplied is not suitable for your socket outlet, it should be removed by unscrewing the plug top, the terminal screws, and removing the cable.

The correct style of plug to suit your household together with a correctly rated fuse should be fitted.

IF IN DOUBT - CONSULT A QUALIFIED ELECTRICIAN

IMPORTANT. DO NOT make any connection to the larger terminal which is marked with the letter E or by the safety earth symbol \perp or coloured Green or Green-and-yellow.

The wires in the mains lead are coloured in accordance with the following codes :-

BLUE - NEUTRAL

BROWN - LIVE

As these colours may not correspond with the coloured markings identifying the terminals in your plug, proceed as follows:

The wire coloured BLUE must be connected to the terminal marked N or coloured BLACK.

The wire coloured BROWN must be connected to the terminal marked L or coloured RED.

Fuse

This apparatus must be protected by a 3A fuse (BS1362) in a 13A plug (BS1363). If another type of plug is used a 5A fuse should be fitted in the plug, adaptor or distribution board.

IF IN DOUBT - CONSULT A QUALIFIED ELECTRICIAN.

Batteries

Remove the battery cover on the rear of the unit by pushing the catches in the direction of the arrows. Insert eight IEC size LR20 batteries (D size) into the compartment. Take care to ensure all batteries are inserted with the correct polarity as shown inside the battery compartment. Replace the battery cover.

Reduced power, distortion, and a 'stuttering' sound are all signs that the batteries may need replacing.

We would recommend for economy, that the SRCD970 is used on the mains whenever possible with battery operation for occasional or stand-by use only.

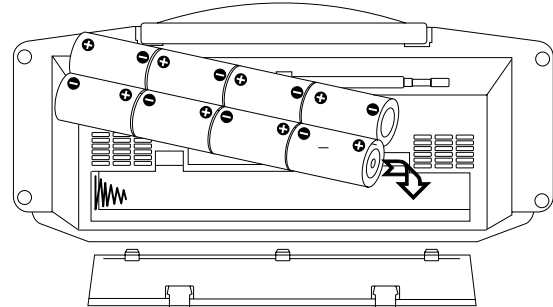

Automatic Mains/Battery switching

To change from battery to mains operation, simply plug the mains lead into the mains input socket on the rear of the unit. The batteries will be automatically disconnected. It does not matter which way round the plug is inserted but make sure it is fully pushed home. The other end should be plugged into a domestic supply socket.

Aerials

The telescopic aerial (5) located on the rear of the SRCD970 is for FM reception. The telescopic aerial should be fully extended and angled for optimum reception

There is a built in ferrite aerial for MW stations. Rotate the SRCD970 to the position giving best reception.

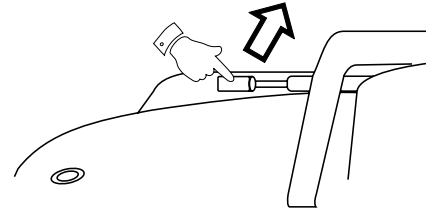

Radio operation (FM)

Slide the Tape/Radio/CD switch (3) to the "Radio" position. Slide the waveband switch (14) to the "FM Stereo" position". Adjust the volume control (4) until a hissing sound is heard. Rotate the tuning control (16) until the desired station is received. If the station being received is in 'Stereo' the stereo indicator (13) will illuminate. Adjust the volume control (4) and tone control (1) to the required settings.

If the FM signal becomes weak or is accompanied by a high level of background hiss, you may select 'MONO' mode by setting the waveband switch (14) to the "FM" position. To switch off the radio, slide the Tape/Radio/CD switch (3) to the "Off/Tape" position.

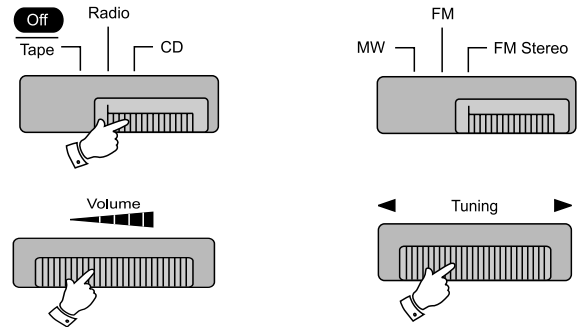

Radio operation (MW)

Slide the Tape/Radio/CD switch (3) to the "Radio" position". Slide the waveband switch (13) to the "MW" position. Adjust the volume control (4) until a hissing sound is heard. Rotate the tuning control (16) until the desired station is received. Adjust the volume control (4) and tone control (1) to the required settings. Rotate the SRCD970 to the position giving best reception. To switch off the radio, slide the Tape/Radio/CD switch (3) to the "Off/Tape" position.

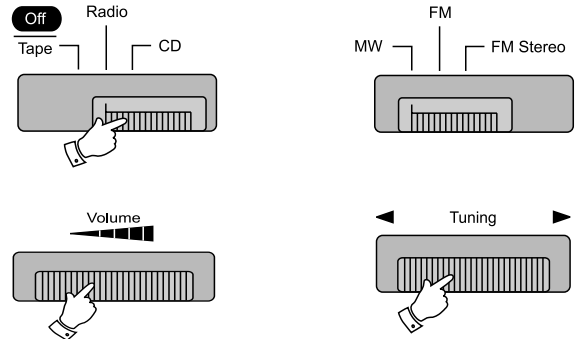

CD operation

Playing a disc

Press the open button (12) to open the CD compartment. Carefully place a disc onto the spindle in the CD compartment, ensuring that the label is facing upwards. Close the lid ensuring it latches shut. Slide the Tape/Radio/CD switch (3) to the "CD" position. The Liquid crystal display (17) will light up if the unit is connected to the mains supply. Press the CD play/pause button (9) to play the disc. Adjust the volume control (4) and tone control (1) to the required settings. To switch off, slide the Tape/Radio/CD switch (3) to the "Off/Tape" position.

Pausing during CD play

Whilst the CD is playing, press the CD play/pause button (9) to pause play. The disc will continue rotating, but play will stop and the pause symbol will appear on the Liquid crystal display (17). To resume play, press the CD play/pause button (9) again. The pause symbol will disappear from the Liquid crystal display.

Stopping CD play

To stop CD play, press the stop button (8). The disc will stop rotating.

Track change function

Whilst the CD is playing, press either the F Skip or B Skip buttons (11) to change to the desired track. You can also change tracks when the player is in stop mode. Change to the desired track using the F Skip or B Skip buttons (11) and press the play/pause button (15) to commence play of the selected track.

Repeat function

To repeat only one track, press the repeat button (7) until the Liquid crystal display shows REPEAT 1.

To repeat all tracks on a disc, press the repeat button (7) until the Liquid crystal display shows REPEAT.

To cancel the repeat function, press the repeat button (7) until the word REPEAT 1 or REPEAT is removed from the Liquid crystal display.

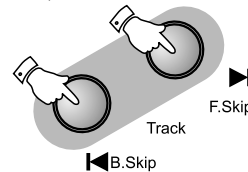
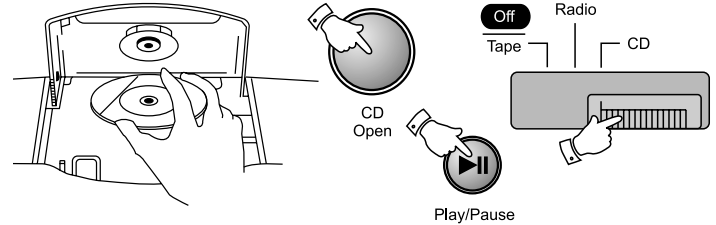

Mixed play

When mixed play is selected the SRCD970 will play all the tracks on the disc in random order. Press the mix button (10) until the word 'Mix' appears in the display. Press the play/pause button (9) to start the disc playing. The SRCD970 will now play all tracks on the disc in random order.



Mix



Play/Pause



Listening to cassette tapes

Slide the Tape/Radio/CD switch (3) to the "Tape" position. Press the stop/eject button (19) to open the cassette door (24). Insert a pre-recorded cassette with the tape surface nearest to the cassette keys and the side with the desired recording facing towards you. Close the cassette compartment. Depress the play button (22) and adjust the volume control (4) to suit your personal taste. Use the fast forward (20) or rewind buttons (21) to locate a specific part of the tape. If you wish to temporarily stop the playback depress the pause button (18). When you are ready to resume playback press the pause button a second time. When the end of tape is reached the SRCD970 will automatically switch off.

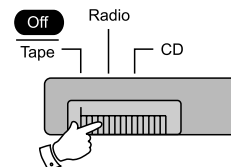

Recording from the Radio

Slide the Tape/Radio/CD switch (3) to the "Radio" position. Tune in to the desired station. Adjust the volume control (4) to suit your requirements. Insert a blank cassette with the tape surface nearest to the cassette keys. Depress the record button (23) to commence recording. The recording level is set automatically and is not affected by the setting of the volume control. When recording from the MW band a whistle may occur. To remove the whistle slide the beat cut switch (25) on the rear of the SRCD970 to the position giving best reception.

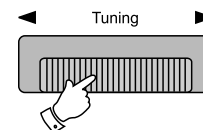
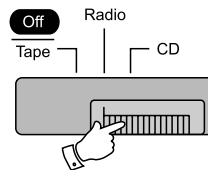
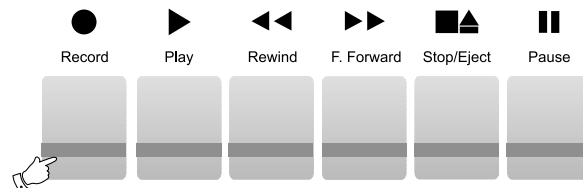

Recording from CD

Press the open button (12) to open the CD compartment. Carefully place a disc onto the spindle in the CD compartment, ensuring that the label is facing upwards. Close the lid ensuring it latches shut. Slide the Tape/Radio/CD switch (3) to the "CD" position. Insert a blank cassette with the tape surface nearest to the cassette keys. Depress the pause (18) and record (23) buttons. Select the required track using the track buttons (11). Press the pause button (18) followed by the CD play/pause button (9) to commence recording.

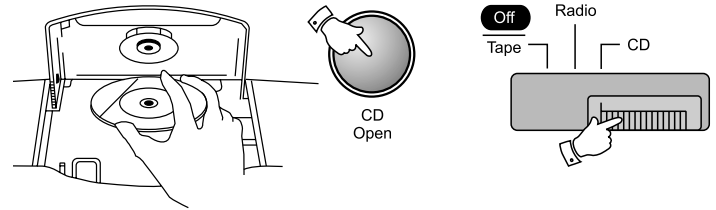

Caution

If the Record button will not depress, do not force it. It is probably because the cassette tabs have been broken to prevent accidental erasure of an existing recording (see preventing accidental erasure).

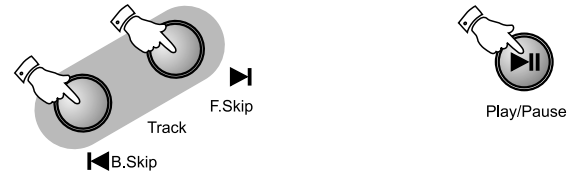
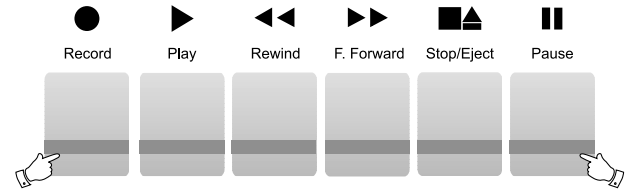

Headphones

A 3.5mm socket (2) on the top of the SRCD970 is provided for use with stereo headphones. Inserting a plug into this socket automatically mutes the internal loudspeakers.

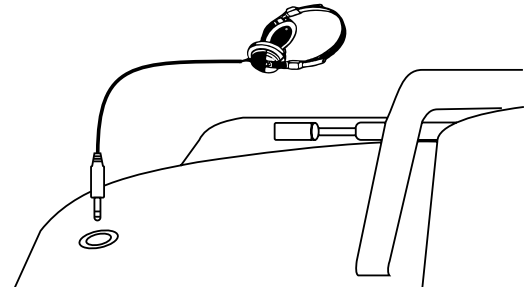

*If you need any further advice, please
call our Technical Helpline on
0181 758 0338 (Mon-Fri)*

Preventing accidental erasure

To safeguard your recordings against accidental erasure, break off the appropriate tab on the cassette as shown. There is one tab for each side of the cassette. This will prevent the Record button from being pressed. To restore the cassette to normal, seal the tab openings with a small piece of self-adhesive tape.

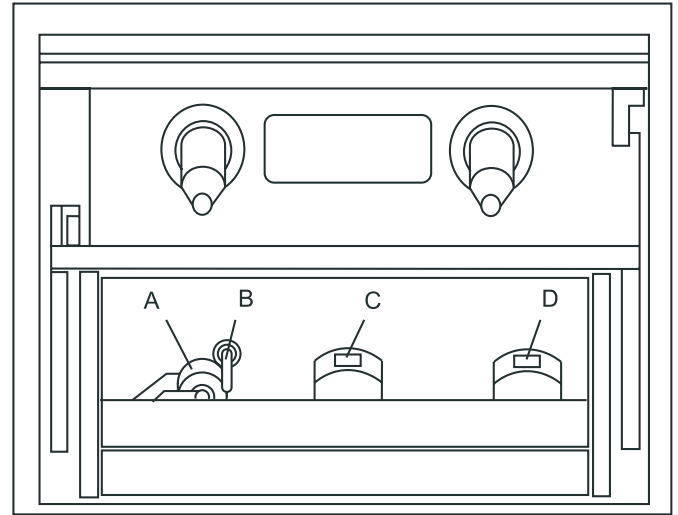
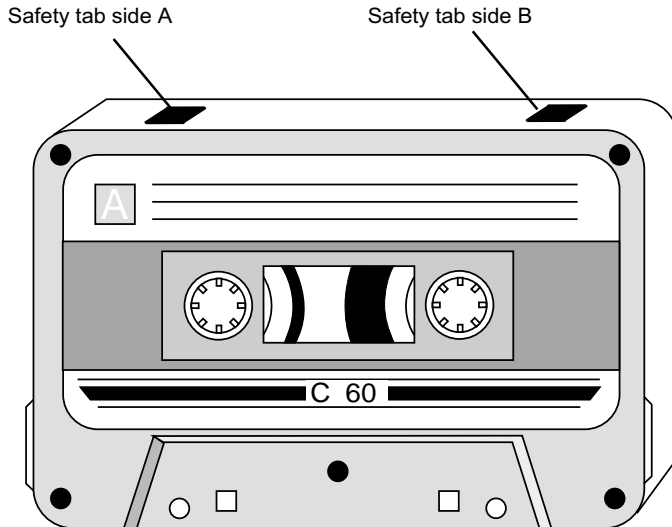

Cleaning the Heads

The binder and oxide from magnetic tapes can accumulate on the pinch roller (A) the capstan shaft (B) and also the heads (C and D). This will impair the sound quality.

To clean these parts proceed as follows:-

1. Turn off the power to the unit.
2. Press the Stop/Eject button (19).
3. Press the Play button (22) and the heads will be clearly seen.
4. Clean the surfaces (A, B, C, D) with a lint free rag or cotton swab soaked in alcohol. Press the stop/eject button as soon as cleaning is over.

Product Care

Do not expose the SRCD970 to extremes of temperature. The product should be kept in a warm environment free from dust and damp. For external cleaning use only a soft, clean cloth. Use a damp cloth to clean the plastic cabinet. A mild soap will help to remove grease or oil. Never use strong detergents or spray cleaners, abrasive powders, thinners or solvents on the machine, as these may cause damage the finish.

CD Player Maintenance

The player mechanism is fitted with self-lubricating bearings, and must not be oiled or greased.

Cleaning compact discs

While CDs do not 'scratch' the way vinyl records do, they are not indestructible. Although the music tracks on the disc are covered with a protective layer, it is still advisable to treat the disc carefully. As long as you always pick up discs by the edge, and put them back in their holders immediately after use, cleaning will not normally be necessary. However, should fingerprints, dust or dirt appear, you can wipe them off with a soft, lint-free cloth. Wipe the disc in a straight line from centre to edge. If the disc is heavily soiled use a commercially available CD cleaner. Detergent or abrasive cleaning agents must never be used. Never write on the disc label – this can cause irreparable damage to the disc.

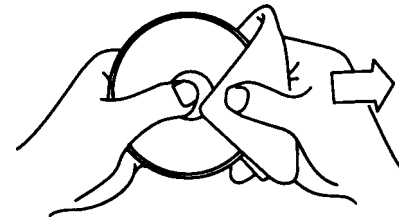

Specifications

Power Requirements

Mains	AC 230 volts, 50Hz \sim only
Batteries	8 x LR20 (D size) (battery life approx. 25 hours)

General

Output Power	2 x 2W RMS
Loudspeakers	2 x 100mm dia 4ohms
Headphone socket	3.5mm stereo

Disc player

Laser wavelength	780nm
Laser power	5mW max
Frequency response	20Hz-20kHz +2db -2dB

Radio

Frequency Coverage

FM	87.5 -108MHz
MW	530 - 1605kHz

Aerial System	FM	Telescopic aerial
	MW	Built-in Ferrite aerial

**CLASS 1
LASER PRODUCT**



DANGER: INVISIBLE LASER
RADIATION WHEN OPEN
AND INTERLOCK FAILED
OR DEFEATED. AVOID
DIRECT EXPOSURE TO BEAM.

Imported by:-

ROBERTS RADIO LIMITED

PO BOX 130

MEXBOROUGH

SOUTH YORKSHIRE

S64 8YT

The Company reserves the right to amend the specification without notice.

Notes:

*If you need any further advice, please
call our Technical Helpline on
0181 758 0338 (Mon-Fri)*

Guarantee

This instrument is guaranteed for twelve months from the date of delivery to the original owner against failure due to faulty workmanship or component breakdown, subject to the procedure stated below. Should any component or part fail during this guarantee period it will be repaired or replaced free of charge.

The guarantee does not cover:

1. Damage resulting from incorrect use.
2. Consequential damage.
3. Receivers with removed or defaced serial numbers.

N.B. Damaged or broken telescopic aerials will not be replaced under guarantee.

Procedure:

Any claim under this guarantee should be made through the dealer from whom the instrument was purchased. It is likely that your Roberts dealer will be able to attend to any defect quickly and efficiently but should it be necessary the dealer will return the instrument to the company's service department for attention. In the event that it is not possible to return the instrument to the Roberts dealer from whom it was purchased, please contact Roberts Radio Technical Services department at the address shown below before taking further action.

These statements do not affect the statutory rights of a consumer.

ROBERTS RADIO TECHNICAL SERVICES DEPARTMENT

97-99 Worton Road

Isleworth Middlesex

TW7 6EG

Technical Helpline :- 0181 758 0338

Issue 1

