

MODEL W1830 HANGING 3-SPEED AIR FILTER



OWNER'S MANUAL

(FOR MODELS MANUFACTURED SINCE 1/12)

Phone: (360) 734-3482 • Online Technical Support: tech-support@shopfox.biz



COPYRIGHT © MARCH, 2012 BY WOODSTOCK INTERNATIONAL, INC. REVISED MAY, 2012 (TR)

WARNING: NO PORTION OF THIS MANUAL MAY BE REPRODUCED IN ANY SHAPE OR FORM WITHOUT

THE WRITTEN APPROVAL OF WOODSTOCK INTERNATIONAL, INC.

#14736TS Printed in China



WARNING!

This manual provides critical safety instructions on the proper setup, operation, maintenance, and service of this machine/tool. Save this document, refer to it often, and use it to instruct other operators.

Failure to read, understand and follow the instructions in this manual may result in fire or serious personal injury—including amputation, electrocution, or death.

The owner of this machine/tool is solely responsible for its safe use. This responsibility includes but is not limited to proper installation in a safe environment, personnel training and usage authorization, proper inspection and maintenance, manual availability and comprehension, application of safety devices, cutting/sanding/grinding tool integrity, and the usage of personal protective equipment.

The manufacturer will not be held liable for injury or property damage from negligence, improper training, machine modifications or misuse.



WARNING!

Some dust created by power sanding, sawing, grinding, drilling, and other construction activities contains chemicals known to the State of California to cause cancer, birth defects or other reproductive harm. Some examples of these chemicals are:

- Lead from lead-based paints.
- Crystalline silica from bricks, cement and other masonry products.
- Arsenic and chromium from chemically-treated lumber.

Your risk from these exposures varies, depending on how often you do this type of work. To reduce your exposure to these chemicals: Work in a well ventilated area, and work with approved safety equipment, such as those dust masks that are specially designed to filter out microscopic particles.

Contents

INTRODUCTION	2	ACCESSORIES	17
Woodstock Technical Support	2	Air Filter Accessories	17
Machine Specifications	3	MAINTENANCE	18
SAFETY	5	Cleaning Filters.....	18
Standard Machinery Safety Instructions	5	SERVICE	19
Additional Safety for Air Filters.....	7	General	19
ELECTRICAL	8	Replacing Fuse.....	19
Circuit Requirements	8	Remote Control Battery Replacement	19
Grounding Requirements.....	9	Electrical Safety Instructions.....	20
Extension Cords	9	Electrical Wiring Diagram.....	21
SETUP	10	Troubleshooting.....	22
Unpacking	10	PARTS	23
Inventory	10	Cabinet & Remote Control.....	23
Power Connection.....	11	Control Panel	24
Test Run.....	12	Motor & Impeller	25
Site Planning.....	13	Label Placement	26
Mounting to Ceiling	14	WARRANTY	29
OPERATIONS	16		
General	16		
Machine Storage.....	16		
Filtering Performance	16		





INTRODUCTION

Woodstock Technical Support

This machine has been specially designed to provide many years of trouble-free service. Close attention to detail, ruggedly built parts and a rigid quality control program assure safe and reliable operation.

Woodstock International, Inc. is committed to customer satisfaction. Our intent with this manual is to include the basic information for safety, setup, operation, maintenance, and service of this product.

We stand behind our machines! In the event that questions arise about your machine, please contact Woodstock International Technical Support at (360) 734-3482 or send e-mail to: tech-support@shopfox.biz. Our knowledgeable staff will help you troubleshoot problems and process warranty claims.

If you need the latest edition of this manual, you can download it from <http://www.shopfox.biz>.

If you have comments about this manual, please contact us at:

Woodstock International, Inc.
Attn: Technical Documentation Manager
P.O. Box 2309
Bellingham, WA 98227
Email: manuals@woodstockint.com



MACHINE SPECIFICATIONS



© Woodstock International, Inc. • Phone: (800) 840-8420 • Web: www.shopfox.biz

MODEL W1830 SHOPFOX HANGING AIR FILTER

Motors

Main

Horsepower.....	1/8 HP
Voltage.....	120V
Phase.....	Single-Phase
Amps.....	1A
Speed.....	1200, 1400, 1750 RPM
Cycle.....	60 Hz
Number of Speeds.....	3

Main Specifications

Operation

Airflow Capacity.....	260, 362, 409 CFM
-----------------------	-------------------

Impeller Information

Impeller Type.....	Squirrel Cage
Impeller Size.....	5-1/2 - 5-1/5 in.

Construction

Frame.....	Steel
Impeller.....	Steel
Paint.....	Powder-Coated
Blower Housing.....	Steel

Product Dimensions

Weight.....	31 lbs.
Width (side-to-side) x Depth (front-to-back) x Height.....	20 in. x 17 in. x 10 in.
Footprint (Length x Width).....	20 in. x 17 in.

Shipping Dimensions

Type.....	Cardboard
Content.....	Machine
Weight.....	34 lbs.
Length x Width x Height.....	24 in. x 20 in. x 13 in.

Other

Warranty	1 Year
Sound Rating	62, 67, 69dB

Controls and Features

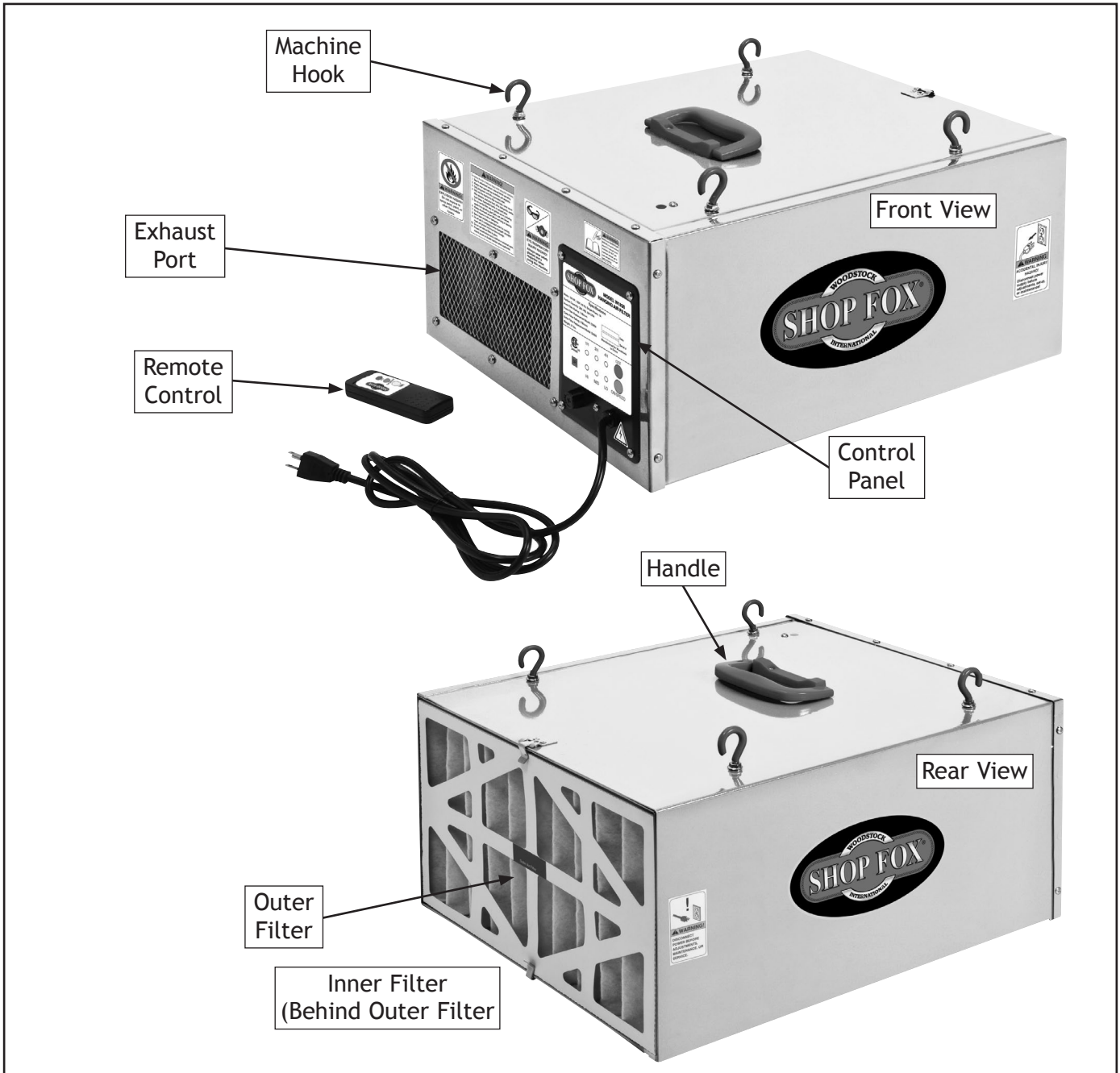

	<p>⚠ WARNING READ and understand this entire manual before using this machine. Serious personal injury may occur if safety and operational information is not understood and followed. DO NOT risk your safety by not reading!</p>
--	--

SAFETY

For Your Own Safety, Read Manual Before Operating Machine

The purpose of safety symbols is to attract your attention to possible hazardous conditions. This manual uses a series of symbols and signal words intended to convey the level of importance of the safety messages. The progression of symbols is described below. Remember that safety messages by themselves do not eliminate danger and are not a substitute for proper accident prevention measures—this responsibility is ultimately up to the operator!



Indicates an imminently hazardous situation which, if not avoided, **WILL** result in death or serious injury.



Indicates a potentially hazardous situation which, if not avoided, **COULD** result in death or serious injury.



Indicates a potentially hazardous situation which, if not avoided, **MAY** result in minor or moderate injury.

NOTICE

This symbol is used to alert the user to useful information about proper operation of the equipment, and/or a situation that may cause damage to the machinery.

Standard Machinery Safety Instructions

OWNER'S MANUAL. Read and understand this owner's manual **BEFORE** using machine. Untrained users can be seriously hurt.

EYE PROTECTION. Always wear ANSI-approved safety glasses or a face shield when operating or observing machinery to reduce the risk of eye injury or blindness from flying particles. Everyday eyeglasses are not approved safety glasses.

HAZARDOUS DUST. Dust created while using machinery may cause cancer, birth defects, or long-term respiratory damage. Be aware of dust hazards associated with workpiece materials, and always wear a NIOSH-approved respirator to reduce your risk.

WEARING PROPER APPAREL. Do not wear clothing, apparel, or jewelry that can become entangled in moving parts. Always tie back or cover long hair. Wear non-slip footwear to avoid accidental slips which could cause a loss of workpiece control.

HEARING PROTECTION. Always wear hearing protection when operating or observing loud machinery. Extended exposure to this noise without hearing protection can cause permanent hearing loss.

MENTAL ALERTNESS. Be mentally alert when running machinery. Never operate under the influence of drugs or alcohol, when tired, or when distracted.

DISCONNECTING POWER SUPPLY. Always disconnect machine from power supply before servicing, adjusting, or changing cutting tools (bits, blades, cutters, etc.). Make sure switch is in **OFF** position before reconnecting to avoid an unexpected or unintentional start.

DANGEROUS ENVIRONMENTS. Do not use machinery in wet or rainy locations, cluttered areas, around flammables, or in poorly-lit areas. Keep work area clean, dry, and well-lit to minimize risk of injury.

APPROVED OPERATION. Untrained operators can be seriously hurt by machinery. Only allow trained or properly supervised people to use machine. When machine is not being used, disconnect power, remove switch keys, or lock-out machine to prevent unauthorized use—especially around children. Make workshop kid proof!

ONLY USE AS INTENDED. Only use machine for its intended purpose. Never modify or alter machine for a purpose not intended by the manufacturer or serious injury may result!

USE RECOMMENDED ACCESSORIES. Consult this owner's manual or the manufacturer for recommended accessories. Using improper accessories will increase the risk of serious injury.

CHILDREN & BYSTANDERS. Keep children and bystanders a safe distance away from work area. Stop using machine if children or bystanders become a distraction.

REMOVE ADJUSTING TOOLS. Never leave adjustment tools, chuck keys, wrenches, etc. in or on machine—especially near moving parts. Verify removal before starting!

SECURING WORKPIECE. When required, use clamps or vises to secure workpiece. A secured workpiece protects hands and frees both of them to operate the machine.

FEED DIRECTION. Unless otherwise noted, feed work against the rotation of blades or cutters. Feeding in the same direction of rotation may pull your hand into the cut.

GUARDS & COVERS. Guards and covers can protect you from accidental contact with moving parts or flying debris. Make sure they are properly installed, undamaged, and working correctly before using machine.

NEVER STAND ON MACHINE. Serious injury or accidental contact with cutting tool may occur if machine is tipped. Machine may be damaged.

STABLE MACHINE. Unexpected movement during operations greatly increases the risk of injury and loss of control. Verify machines are stable/secure and mobile bases (if used) are locked before starting.

FORCING MACHINERY. Do not force machine. It will do the job safer and better at the rate for which it was designed.

AWKWARD POSITIONS. Keep proper footing and balance at all times when operating machine. Do not overreach! Avoid awkward hand positions that make workpiece control difficult or increase the risk of accidental injury.

UNATTENDED OPERATION. Never leave machine running while unattended. Turn machine off and ensure all moving parts completely stop before walking away.

MAINTAIN WITH CARE. Follow all maintenance instructions and lubrication schedules to keep machine in good working condition. An improperly maintained machine may increase the risk of serious injury.

CHECK DAMAGED PARTS. Regularly inspect machine for damaged parts, loose bolts, mis-adjusted or mis-aligned parts, binding, or any other conditions that may affect safe operation. Always repair or replace damaged parts, wires, cords, or plugs before operating machine.

MAINTAIN POWER CORDS. When disconnecting cord-connected machines from power, grab and pull the plug—NOT the cord. Pulling the cord may damage the wires inside. Do not handle the cord/plug with wet hands. Avoid cord damage by keeping it away from heated surfaces, high traffic areas, harsh chemicals, and wet or damp locations.

EXPERIENCING DIFFICULTIES. If at any time you are experiencing difficulties performing the intended operation, stop using the machine! Contact our Technical Support for help at (360) 734-3482.

Additional Safety for Air Filters

INTENDED USE. This air filter is designed to capture dust from ambient air in a woodworking shop for a short time after cutting or sanding operations. **DO NOT** use this air filter to collect particles of silica, metal, lead paint, asbestos, or hazardous bacterium. **DO NOT** allow this filter to collect liquids, combustible fumes, burning or smoking material, or toxic fumes.

HAZARDOUS DUST. Dust exposure may cause cancer, birth defects, or long-term respiratory damage. Be aware of the dust hazards associated with each workpiece material, and always wear a NIOSH-approved respirator to reduce your risk.

LEAD PAINT DUST AND ASBESTOS FIBERS. **DO NOT** try to collect lead paint or asbestos fibers with this machine. Due to the high hazard to human health, these materials must be collected with special equipment.

DUST ALLERGIES. Dust from certain woods may cause an allergic reaction in people and animals. Make sure you know what type of wood dust you will be exposed to in case there is a possibility of an allergic reaction.

WEAR RESPIRATOR. Fine dust that is too small to be caught in the filter will be blown into the ambient air during operation. Wearing a NIOSH approved respirator during this time will reduce your risk of permanent respiratory damage.

EMPTYING DUST. When removing dust from the filters, turn **OFF** the switch, disconnect power, and wear a respirator and safety glasses. Empty dust away from ignition sources and into an approved container.

DISCONNECTING POWER SUPPLY. Turn the switch **OFF**, disconnect the air filter from the power supply, and allow the impeller to come to a complete stop before leaving the machine unattended or doing any service, cleaning, maintenance, or adjustments.

REGULAR CLEANING. For best performance, regularly check/clean the filters to avoid the buildup of fine dust. Make sure to regularly clean the surrounding area where the machine is operated—excessive dust buildup on overhead lights, heaters, electrical panels, or other heat sources will increase the risk of fire.

SUSPENDED DUST PARTICLES AND IGNITION SOURCES. **DO NOT** operate the air filter in areas where explosion risks are high. Areas of high risk include, but are not limited to, areas near pilot lights, open flames, or other ignition sources.

FIRE SUPPRESSION. Only operate the air filter in locations that contain a fire suppression system or have a fire extinguisher nearby.

IMPELLER HAZARDS. **DO NOT** place your hands or tools inside the air filter housing during operation for any reason. The powerful suction could easily cause accidental contact with the impeller which could cause serious personal injury or damage to the machine.

OPERATING LOCATION. **DO NOT** operate the air filter in rainy or wet locations—exposure to water may create a shock hazard or decrease the life of the machine.

CAUTION

USE this and other machinery with caution and respect. Always consider safety first, as it applies to your individual working conditions. No list of safety guidelines can be complete—every shop environment is different. Failure to follow guidelines could result in serious personal injury, damage to equipment or poor work results.

ELECTRICAL

Circuit Requirements

This machine must be connected to the correct size and type of power supply circuit, or fire or electrical damage may occur. Read through this section to determine if an adequate power supply circuit is available. If a correct circuit is not available, a qualified electrician **MUST** install one before you can connect the machine to power.

A power supply circuit includes all electrical equipment between the breaker box or fuse panel in the building and the machine. The power supply circuit used for this machine must be sized to safely handle the full-load current drawn from the machine for an extended period of time. (If this machine is connected to a circuit protected by fuses, use a time delay fuse marked D.)

Full-Load Current Rating

The full-load current rating is the amperage a machine draws at 100% of the rated output power. On machines with multiple motors, this is the amperage drawn by the largest motor or sum of all motors and electrical devices that might operate at one time during normal operations.

Full-Load Current Rating at 120V 1 Amp

Circuit Requirements for 120V

This machine is prewired to operate on a 120V power supply circuit that has a verified ground and meets the following requirements:

- Circuit Type 120V, 60 Hz, Single-Phase
- Circuit Size 15 Amps
- Plug/Receptacle NEMA 5-15

⚠ WARNING

The machine must be properly set up before it is safe to operate. **DO NOT** connect this machine to the power source until instructed to do later in this manual.

⚠ WARNING



Incorrectly wiring or grounding this machine can cause electrocution, fire, or machine damage. To reduce this risk, only an electrician or qualified service personnel should do any required electrical work on this machine.

NOTICE

The circuit requirements listed in this manual apply to a dedicated circuit—where only one machine will be running at a time. If this machine will be connected to a shared circuit where multiple machines will be running at the same time, consult a qualified electrician to ensure that the circuit is properly sized for safe operation.

ELECTRICAL

Grounding Requirements

This machine **MUST** be grounded. In the event of certain types of malfunctions or breakdowns, grounding provides a path of least resistance for electric current to travel—in order to reduce the risk of electric shock.

Improper connection of the equipment-grounding wire will increase the risk of electric shock. The wire with green insulation (with/without yellow stripes) is the equipment-grounding wire. If repair or replacement of the power cord or plug is necessary, do not connect the equipment-grounding wire to a live (current carrying) terminal.

Check with a qualified electrician or service personnel if you do not understand these grounding requirements, or if you are in doubt about whether the tool is properly grounded. If you ever notice that a cord or plug is damaged or worn, disconnect it from power, and immediately replace it with a new one.

For 120V Connection

This machine is equipped with a power cord that has an equipment-grounding wire and NEMA 5-15 grounding plug. The plug must only be inserted into a matching receptacle (see **Figure**) that is properly installed and grounded in accordance with local codes and ordinances.

Extension Cords

We do not recommend using an extension cord with this machine. Extension cords cause voltage drop, which may damage electrical components and shorten motor life. Voltage drop increases with longer extension cords and the gauge smaller gauge sizes (higher gauge numbers indicate smaller sizes).

Any extension cord used with this machine must contain a ground wire, match the required plug and receptacle, and meet the following requirements:

- Minimum Gauge Size at 120V 14 AWG
- Maximum Length (Shorter is Better) 50 ft.

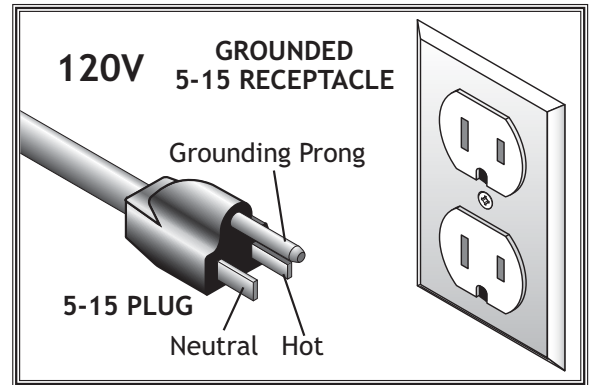

Figure 1. NEMA 5-15 plug & receptacle.

⚠ CAUTION

DO NOT modify the provided plug or use an adapter if the plug will not fit the receptacle. Instead, have an electrician install the proper receptacle on a power supply circuit that meets the requirements for this machine.

ELECTRICAL

SETUP

Unpacking

This machine has been carefully packaged for safe transportation. If you notice the machine has been damaged during shipping, please contact your authorized Shop Fox dealer immediately.

Inventory

The following is a description of the main components shipped with the Model W1830. Lay the components out to inventory them.

Note: *If you can't find an item on this list, check the mounting location on the machine or examine the packaging materials carefully. Occasionally we pre-install certain components for safer shipping.*

Shipping Inventory: (Figure 2)	Qty
A. Air Filter Unit	1
B. Hanging Chains.....	4
C. Ceiling Hooks.....	4
D. Machine Hooks	4
E. Remote Control w/Batteries.....	1

Installed & Not Shown	Qty
• Outer Filter.....	1
• Inner Filter	1

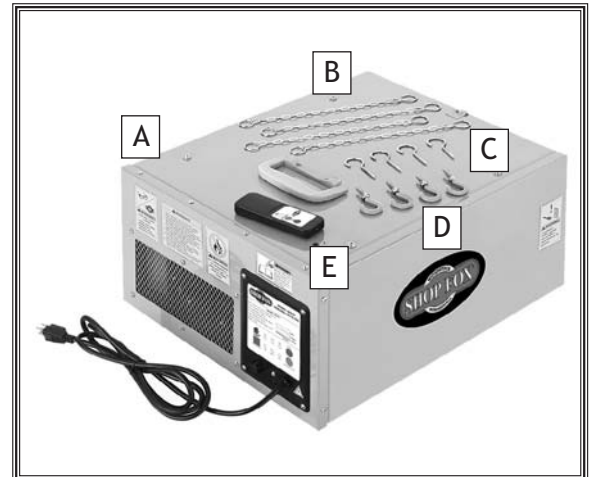
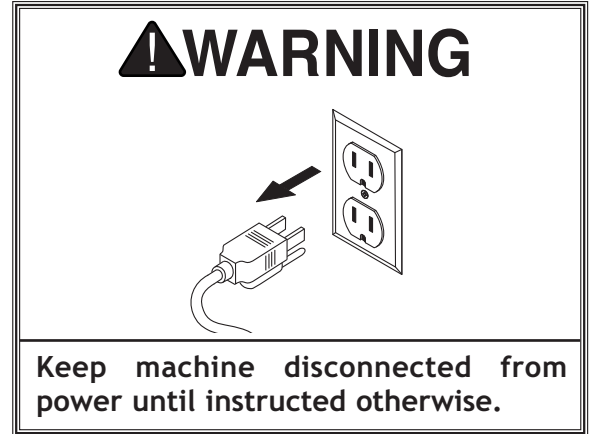

Figure 2. Shipping inventory.

SETUP

Power Connection

To avoid unexpected startups or property damage, use the following steps whenever connecting or disconnecting the machine.

Connecting Power

Insert the power cord plug into a matching power supply receptacle. The machine is now connected to the power source.

Disconnecting Power

Grasp the molded plug and pull it completely out of the receptacle. Do not pull by the cord as this may damage the wires inside.

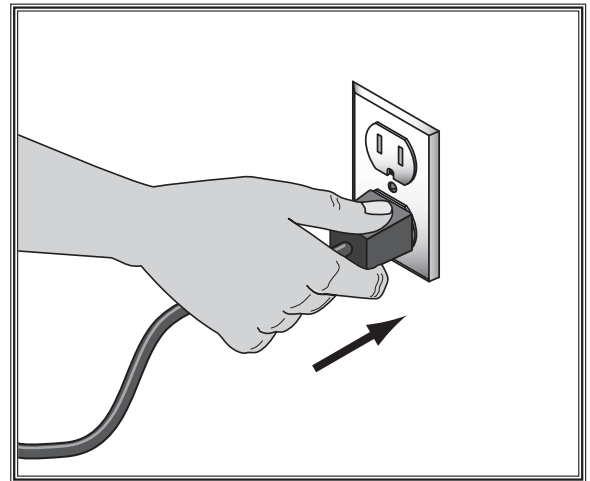

Figure 3. Connecting power.

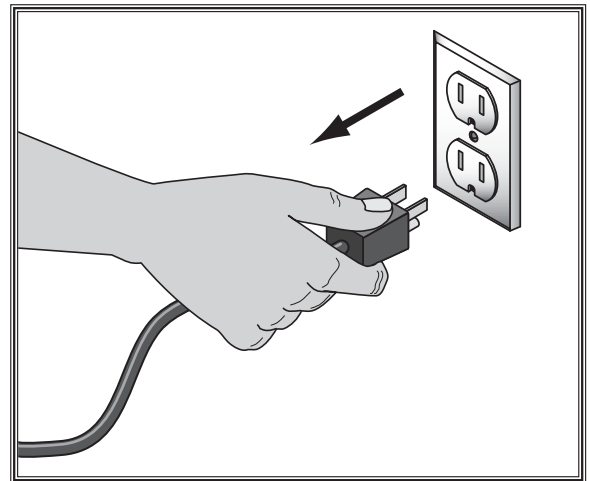

Figure 4. Disconnecting power.

SETUP

Test Run

Once you have unpacked the machine, perform a test run before mounting to the ceiling to make sure it runs properly.

If, during the test run, you cannot easily locate the source of an unusual noise or vibration, stop using the machine immediately, then review the **Troubleshooting** on **Page 20**.

If you still cannot remedy a problem, contact our Tech Support at (360) 734-3482 for assistance.

To test run the machine, do these steps:

1. Make sure you have read the safety instructions at the beginning of the manual.
2. Place the air filter on a workbench or similar stable surface that can support the load.
3. Connect the air filter to power.
4. Press the ON SPEED button on the control panel of the air filter (see **Figure 5**) to turn the unit **ON**. The machine should begin to operate.

– Strange or unusual noises should be investigated and corrected before operating the machine further. Always disconnect the machine from power when investigating or correcting potential problems.

Note: Do not be alarmed if you notice a small amount of vibration during the Test Run. It is normal for all air filters to produce a small amount of vibration during operation. This vibration is much more noticeable when operating on a hard surface, such as a workbench, compared to when operating in a suspended position, as designed.

5. Push the ON SPEED button repeatedly to cycle through the three air flow speed options. The lights on the control panel should display the selected speed.
6. Press the OFF button to turn the machine **OFF**.
7. Point the remote control directly at the control panel, and press the remote control ON SPEED button to turn the machine **ON**.



Figure 5. Air filter control panel.

8. Push the remote control ON SPEED button (see **Figure 6**) repeatedly to cycle through the air flow options. The lights on the control panel should display the selected speed.
9. Push the remote control TIME button repeatedly to cycle through the three time options. The lights on the control panel should display the amount of time the air filter will run before automatically turning **OFF**.
10. Press the remote control OFF button to turn the air filter **OFF**.



Figure 6. Remote control.

SETUP

Site Planning

Site planning is an important step to maximize the effectiveness of the hanging air filter. Air circulation must be thought out and all obstructions to the air path considered.

Think of air circulation in terms of the circular motion of the air before and after the air filter. The air exiting the filter is exhausted at a higher velocity than that entering it. Consequently, exhaust being vented inside a building can have an effect on the pattern of air circulation.

Air circulation patterns will vary depending upon which air flow speed is used and according to your specific shop setup. **Figure 7** shows an example of good air circulation.

Figure 8 shows an example of poor air circulation, where the air filter is placed too close to obstructions. In this situation, the velocity of the air is lost and circulation is diminished.

Below is a list of things to keep in mind when selecting a spot for the air filter:

- Study your shop layout and try to determine the best location for the hanging air filter. Air flow that is obstructed will cause a short cycle effect, producing unsatisfactory results. There must be a clearance of at least 3 ft. from any obstructions in front and back of the unit.
- Try to place the air filter in front of high dust producers like sanders or near areas where sanding will take place.
- Do not place the hanging air filter where garage doors may pass closely or where it may impede transport or movement of any other object.
- Try to place the unit where it is easy to access for turning it on, cleaning and maintenance.

It is very important that the hanging air filter be supported properly. Please follow these guidelines when planning where to mount the unit:

- Where the mounting brackets attach is the top of the unit. The hanging air filter can only be secured by the machine hooks on its top.

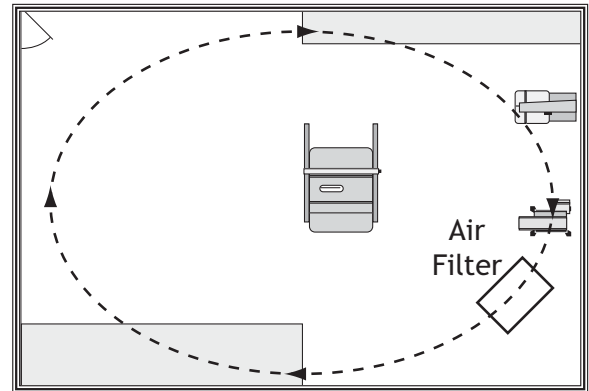

Figure 7. The air filter placement promotes GOOD circular air motion.

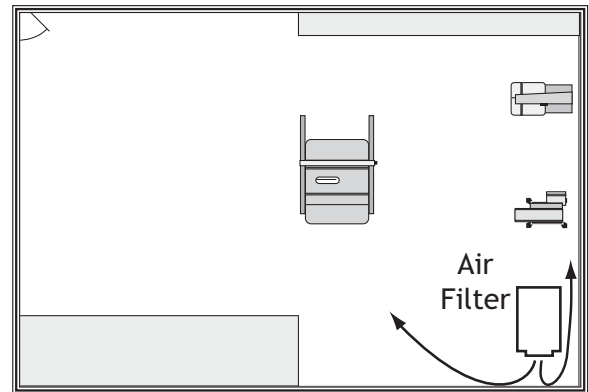

Figure 8. The air filter placement is too close to the walls and leaves much of the room unfiltered.

- Make sure that an electrical outlet with a properly grounded receptacle is available at the location you choose.
- The hanging air filter must be supported by wood joists that are capable of supporting at least 100 lbs each. DO NOT attach the hanging air filter to only sheet rock, press board or paneling. These materials cannot support the filter, and it may fall.
- Avoid hitting your head on the hanging air filter. Make sure there is enough clearance between the unit and the ground, especially important in a basement. If possible, position the air filter in an area that has little foot traffic but still offers easy access to the switch and filters.

SETUP

Mounting to Ceiling

The Model W1830 performs best when hung from the ceiling.

The advantage of having the air filter mounted to the ceiling is that the air circulation pattern is not blocked by equipment and obstacles closer to the floor.

When choosing a location to mount the air filter to the ceiling, keep in mind the clearance necessary underneath the machine for foot traffic or other operations. The mounting chains can be used at full length, which will bring the bottom of the air filter to approximately 25½" from the ceiling, or the chains can be doubled-up, which will bring the unit approximately 19½" below the ceiling.

Important: *The ceiling hooks must only be screwed into solid wood. Otherwise, they may pull out under load and cause the air filter to fall.*

To mount the air filter to the ceiling, do these steps:

1. Replace the four Phillips head screws shown in **Figure 9** with the four provided machine hooks (see **Figure 10**).
2. Tighten each hex nut on the hooks against the air filter body to secure them in place.

⚠ WARNING

ONLY mount the air filter unit to joists or table that can hold at least 100 lbs. **DO NOT** mount the unit only to sheet rock, pressboard, paneling, or honeycomb wall panels with expansion-type fasteners. The fasteners can tear out and the air filter can fall. Ignoring this caution can result in injury or property damage.

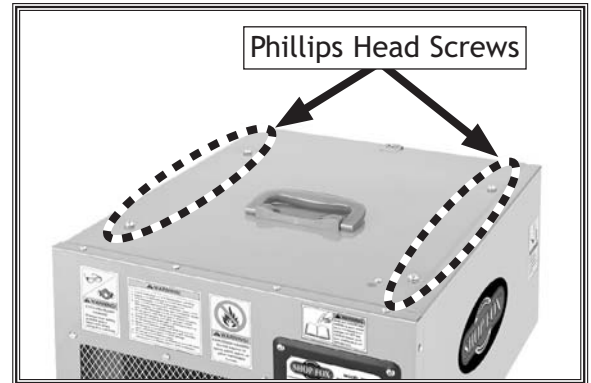

Figure 9. Remove these Phillips head screws.

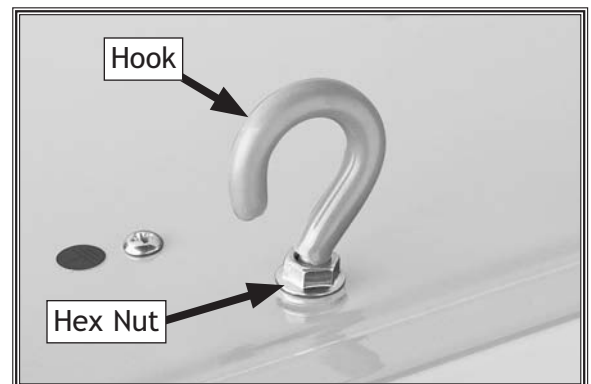

Figure 10. Machine hook installed.

Note: Some positions for the ceiling hooks may be slightly uneven from each another. To make up for this, minor adjustments can be made to the length of the hanging assembly by adjusting the amount that the machine hook is threaded into the air filter housing (see **Figure 11**). After adjusting the hook height, tighten the hex nut to secure the hook.

3. Drill a $\frac{3}{32}$ " pilot hole into the center of the joists at the mounting locations, then fully thread the ceiling hooks into the joists (see **Figure 12**).

Important: If the joists are covered with sheet rock or paneling, use a stud finder or other device to locate the center of the joists.

4. Attach the provided chains to the ceiling hooks.
5. With the help of another person to hold the air filter up, attach the other end of the chains to the machine hooks.

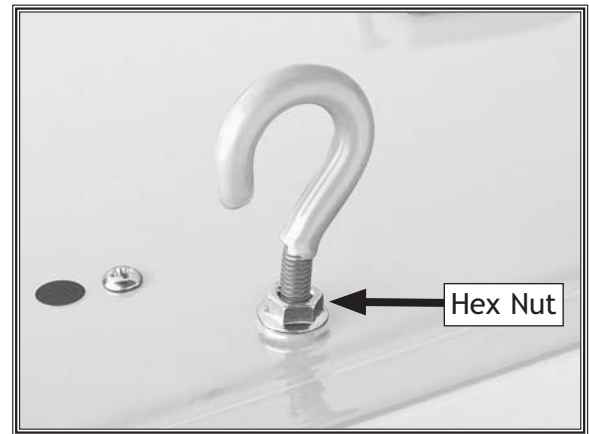

Figure 11. Machine hook partially threaded to adjust the hanging length.

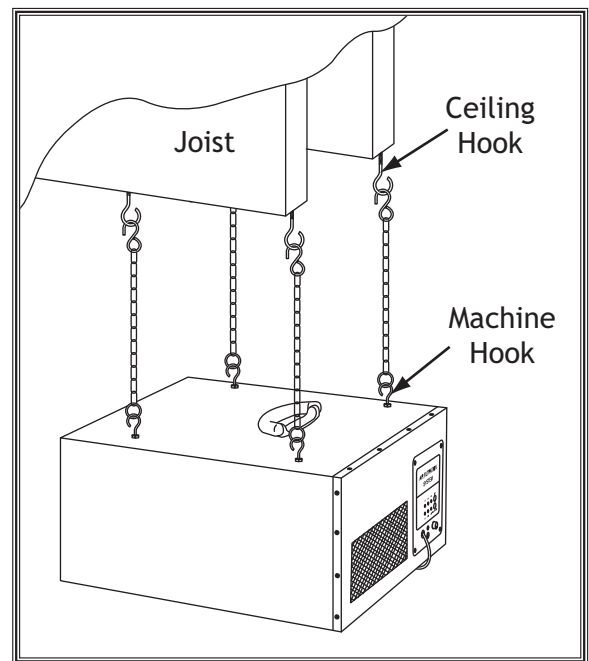

Figure 12. Air filter mounted to the joists.

⚠️ WARNING

THIS AIR FILTER IS TO BE USED FOR WOOD DUST ONLY. Do not use it to filter toxic fumes, paint spray, or dissipate smoke or fumes, which could damage the filters.

SETUP

OPERATIONS

General

Turning ON & OFF

When the air filter is connected to power, press the ON SPEED button on the air filter control panel or the remote control to turn the unit **ON**.

Note: *The remote control communicates with the air filter using infrared (IR) and must be pointed directly at the air filter control panel to work properly.*

Changing Air Flow Speeds

The air filter can be set to operate in three air flow speeds—260 (LO), 362 (MED), and 409 CFM (HI). CFM is the acronym for Cubic Feet per Minute of air flow that is generated through the air filter.

To cycle through the available speeds, press the ON SPEED button on the control panel or remote control repeatedly. This will illuminate the corresponding lights on the control panel.

Setting Timer

The air filter can be set for a timed performance of 1, 2, or 4 hours. At the end of this time, the air filter will automatically turn **OFF**.

To cycle through the available time settings, press the TIME button on the remote control repeatedly. This will illuminate the corresponding lights on the control panel.

Machine Storage

When the air filter is not in use, unplug the power cord from the power source. Secure the power cord away from potential hazards, such as high traffic areas, sharp objects, heat sources, harsh chemicals or fumes, damp areas, etc.

Filtering Performance

When used in conjunction with an efficient dust collection system, the Model W1830 removes most fine wood particles up to 1 micron from the air. This air filter is capable of recirculating the air in a room measuring 20' x 20' x 8' approximately 7.7 times an hour. We recommend that the volume of air in your room be recirculated 6-9 times an hour for the best filtering effect.

Therefore, rooms with a larger volume may require two or more air filters to achieve proper filtering.

To calculate the recirculating rate for your shop space, do these steps:

1. Calculate the volume of air in your shop by multiplying the length x width x height of the room (see the example below). Then, divide the volume by the speed (CFM) you have chosen to operate the air filter. This will give you how many minutes it takes to recirculate the air in the room.

Example: *The room measures 20' x 20' x 8' and you are operating the air filter at 409 CFM (HI).*

$$\frac{20' \times 20' \times 8'}{409 \text{ CFM}} = \frac{3200 \text{ ft}^3}{409 \text{ CFM}} = 7.8 \text{ Minutes}$$

2. Calculate how many times per hour the room volume is recirculated through the air filter by dividing 60 minutes by the circulating time from **Step 1**. This will give you how many times an hour the air in the room is recirculated through the air filter.

$$\frac{60 \text{ Min.}}{7.8 \text{ Min.}} = 7.7 \text{ Times per Hour}$$

ACCESSORIES

Air Filter Accessories

The following Air Filter accessories may be available through your local Woodstock International Inc. Dealer. If you do not have a dealer in your area, these products are also available through online dealers. Please call or e-mail Woodstock International Inc. Customer Service to get a current listing of dealers at: 1-800-840-8420 or at sales@woodstockint.com.

D3834—Inner Filter for Model W1830

D3835—Outer Filter for Model W1830

We recommend that you keep a set of filters on hand to ensure uninterrupted service of your air filter.

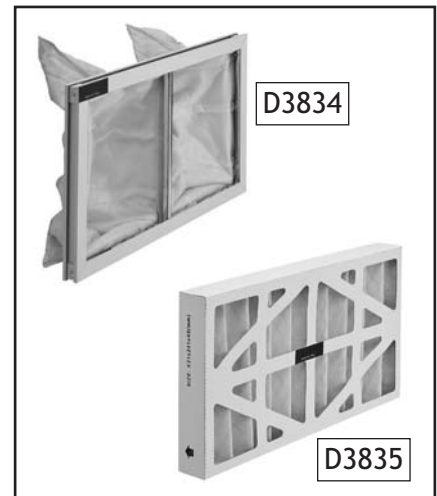

The **Shop Fox Model W1746** is one machine that will sit in the shop and gather dust—fine dust that is! With its three speed fan, automatic shut-off and 0.3 micron filter, this fine dust air filter circulates shop air and captures the fine dust that otherwise stays suspended. Even with an efficient dust collector, if other machines are making dust, you need this fine air filter.



MAINTENANCE

Cleaning Filters

The amount of air filter operation has a direct bearing on when you must clean or replace the filters.

To maintain efficient operation, check the filters approximately every 40 hours of use in light or moderately dusty environments. In very dusty environments, check the filters every eight hours of use. Always wear a respirator when checking the filters.

To change and service the filters, do these steps:

1. DISCONNECT MACHINE FROM POWER!
2. Un-latch the filter retaining clips from the top and bottom of the unit, as shown in **Figure 13**, and remove the outer filter. Place the filter in a trash bag and shake it gently to remove the bulk of the dust.

If you choose to use compressed air to further clean the filter, do so outdoors and in an appropriate environment where people are not in the immediate vicinity.

3. Remove the inner filter, place it inside a trash bag and gently shake the dust from the inside of the filter.

Optional: Wash the inner filter with water to remove the remaining dust, then let it air dry completely.

4. Re-install the inner filter, then re-install the outer filter with the wire mesh facing to the inside.
5. Re-latch the retaining clips to secure the filters.

Note: During regular use the filters can be cleaned several times before replacement becomes necessary. To determine whether the filters need to be replaced, hold them up to the sunlight and visually inspect them. If you cannot see through the filters due to caked dust and grim, replace them before putting air filter back into operation.

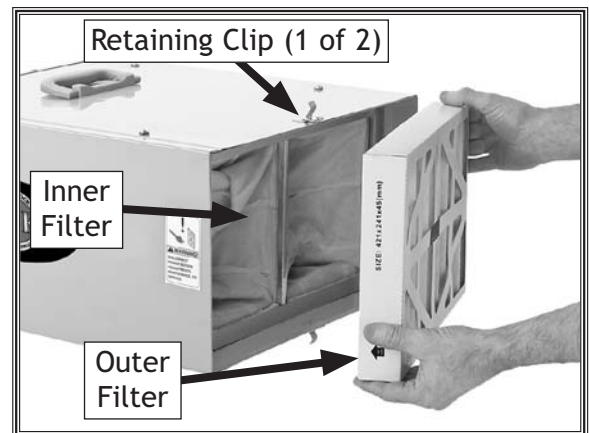
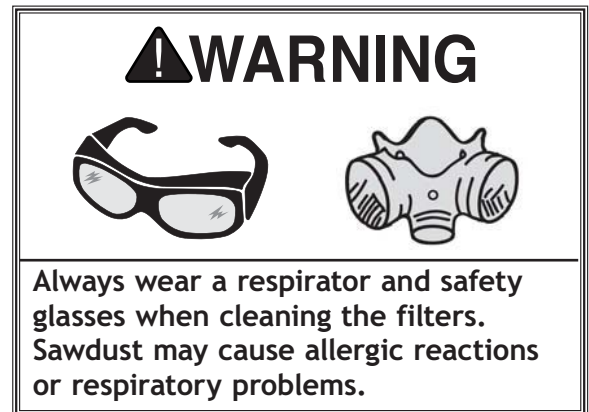

Figure 13. Filters exposed for cleaning.

SERVICE

General

This section covers the most common service adjustments or procedures that may need to be made during the life of your machine.

If you require additional machine service not included in this section, please contact Woodstock International Technical Support at (360) 734-3482 or send e-mail to: tech-support@shopfox.biz.

Replacing Fuse

The fuse on the control panel will blow in the case of a thermal overload.

Replace the fuse only with a fast-acting, 2 amp, 250V fuse (Part Number X1830055).

Tool Needed Qty
Phillips Screwdriver #2.....1

To replace the machine fuse, do these steps:

1. DISCONNECT MACHINE FROM POWER!
2. Unthread the fuse holder cap from the control panel (see Figure 14) and remove it. The fuse will come out with it.
3. Replace the fuse and fully thread the cap in to secure it.

Remote Control Battery Replacement

The remote control uses two AA batteries. To replace them, slide the battery compartment cover down and off the remote (see Figure 15). Insert the batteries in the proper direction and replace the cover.

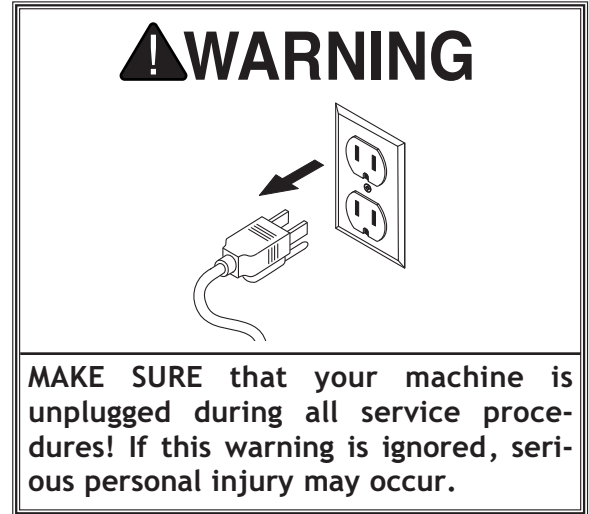

Figure 14. Fuse holder cap on the control panel.

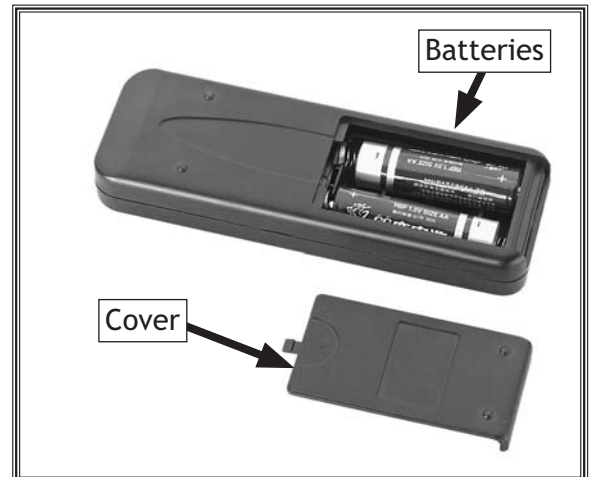
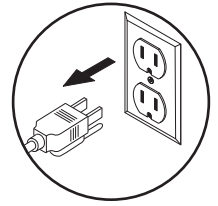

Figure 15. Remote control battery compartment cover removed.

SERVICE

Troubleshooting



This section covers the most common problems and corrections with this type of machine. **WARNING! DO NOT** make any adjustments until power is disconnected and moving parts have come to a complete stop!

PROBLEM	POSSIBLE CAUSE	CORRECTIVE ACTION
Machine does not start or a breaker trips.	<ol style="list-style-type: none"> 1. Power supply switched <i>OFF</i> or is at fault. 2. Remote control not working or batteries are dead. 3. Infrared transmission is blocked or remote too far away. 4. Wall circuit breaker tripped. 5. Control panel fuse blown. 6. Wiring is open/has high resistance. 7. Infrared receiver at fault. 8. Control panel ON SPEED button at fault. 9. Motor at fault. 	<ol style="list-style-type: none"> 1. Ensure power supply is ON/has correct voltage. 2. Replace batteries; point remote control directly at control panel. 3. Make sure the infrared receiver on the control panel is not blocked; try using the remote closer to the filter. 4. Ensure circuit size is correct/replace weak breaker. 5. Check filters/resolve reason for blown fuse; replace fuse (see Page 19). 6. Check/fix broken, disconnected, or corroded wires. 7. Inspect/replace if faulty. 8. Replace faulty ON SPEED button. 9. Test/repair/replace.
Machine stalls or is under-powered.	<ol style="list-style-type: none"> 1. Motor overheated. 2. Run capacitor at fault. 3. Motor at fault. 	<ol style="list-style-type: none"> 1. Clean filters to reduce load on motor. 2. Test/repair/replace. 3. Test/repair/replace.
Machine has vibration or noisy operation.	<ol style="list-style-type: none"> 1. Motor or component loose. 2. Motor fan rubbing on fan cover. 3. Motor bearings at fault. 	<ol style="list-style-type: none"> 1. Inspect/replace damaged bolts/nuts, and re-tighten with thread locking fluid. 2. Fix/replace fan cover; replace loose/damaged fan. 3. Test by rotating shaft; rotational grinding/loose shaft requires bearing replacement.
Loud, repetitious noise, or excessive vibration coming from air filter.	<ol style="list-style-type: none"> 1. Air filter is not mounted properly and wobbles. 2. Impeller fan is damaged, loose, or severely unbalanced. 3. The motor mounting is loose. 4. Motor fan housing is dented, causing the motor fan blade to hit the housing while spinning. 	<ol style="list-style-type: none"> 1. Stabilize the air filter. 2. Unplug air filter, and inspect the impeller for dents, bends, loose fins. Replace impeller if any damage is found. 3. Make sure all fasteners on the air filter are tight. 4. Replace motor fan housing.
Air filter does not adequately collect dust; poor performance.	<ol style="list-style-type: none"> 1. The filters are dirty. 	<ol style="list-style-type: none"> 1. Clean the filters.

Electrical Safety Instructions

These pages are current at the time of printing. However, in the spirit of improvement, we may make changes to the electrical systems of future machines. Study this diagram carefully. If you notice differences between your machine and these wiring diagrams, call Woodstock International Technical Support at (360) 734-3482.

WARNING

1. **SHOCK HAZARD.** Working on wiring that is connected to a power source is extremely dangerous. Touching electrified parts will result in personal injury including but not limited to severe burns, electrocution, or death. Disconnect the power from the machine before servicing electrical components!
2. **QUALIFIED ELECTRICIAN.** Due to the inherent hazards of electricity, only a qualified electrician should perform wiring tasks on this machine. If you are not a qualified electrician, get help from one before attempting any kind of wiring job.
3. **WIRE CONNECTIONS.** All connections must be tight to prevent wires from loosening during machine operation. Double-check all wires disconnected or connected during any wiring task to ensure tight connections.
4. **WIRE/COMPONENT DAMAGE.** Damaged wires or components increase the risk of serious personal injury, fire, or machine damage. If you notice that any wires or components are damaged while performing a wiring task, replace those wires or components before completing the task.
5. **MOTOR WIRING.** The motor wiring shown in these diagrams is current at the time of printing, but it may not match your machine. Always use the wiring diagram inside the motor junction box.
6. **MODIFICATIONS.** Using aftermarket parts or modifying the wiring beyond what is shown in the diagram may lead to unpredictable results, including serious injury or fire.
7. **CAPACITORS/INVERTERS.** Some capacitors and power inverters store an electrical charge for up to five minutes after being disconnected from the power source. To avoid being shocked, wait at least this long before working on these components.
8. **ELECTRICAL REQUIREMENTS.** You **MUST** follow the electrical requirements at the beginning of this manual when connecting your machine to a power source.
9. **EXPERIENCING DIFFICULTIES.** If you are experiencing difficulties understanding the information included in this section, contact our Technical Support at (360) 734-3482.

NOTICE

The photos and diagrams included in this section are best viewed in color. You can view these pages in color at www.shopfox.biz.

WIRING DIAGRAM COLOR KEY

BLACK	BLUE	YELLOW	LIGHT BLUE
WHITE	BROWN	YELLOW GREEN	BLUE WHITE
GREEN	GRAY	PURPLE	TURQUOISE
RED	ORANGE	PINK	

SERVICE

Electrical Wiring Diagram

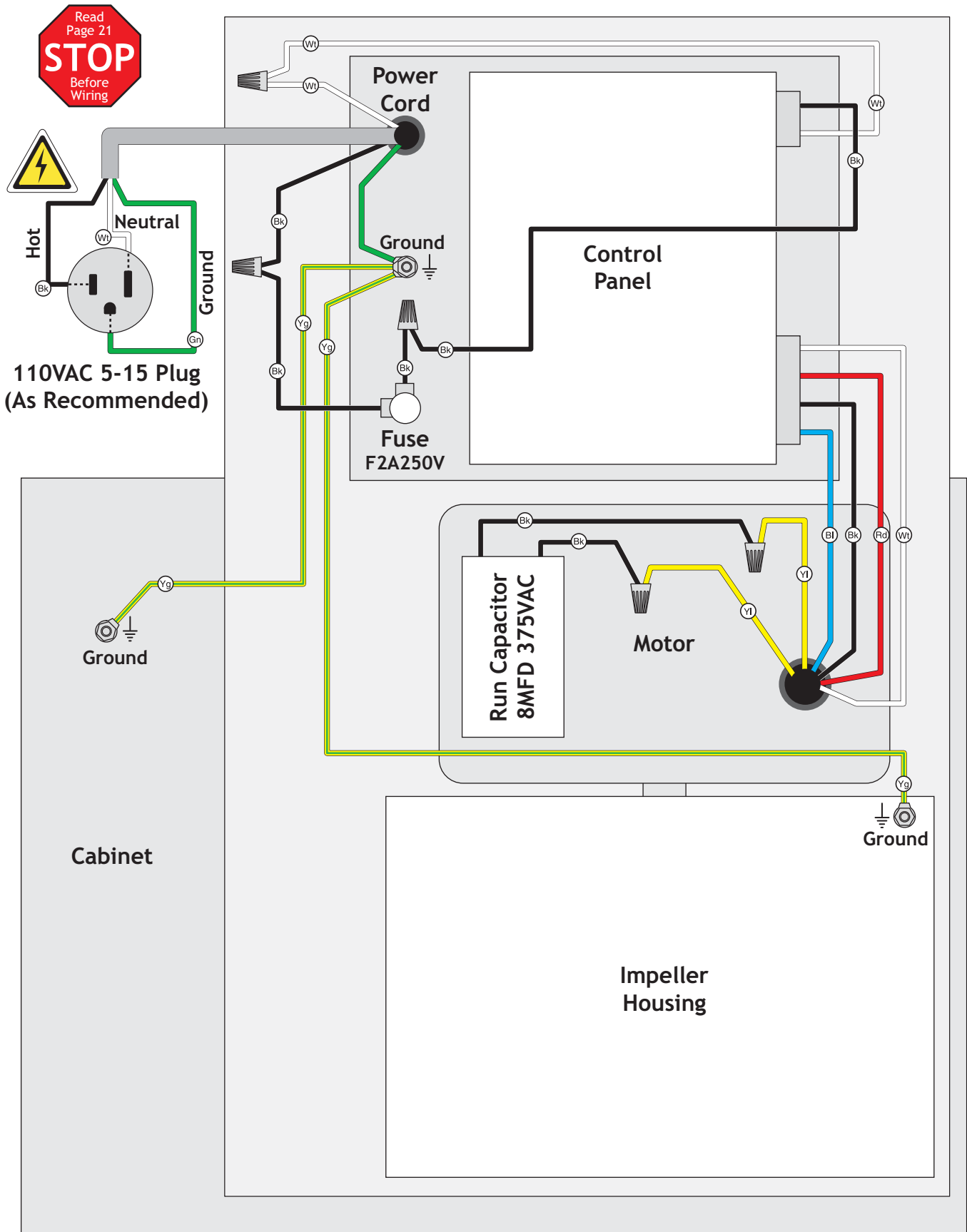

SERVICE

PARTS

Cabinet & Remote Control

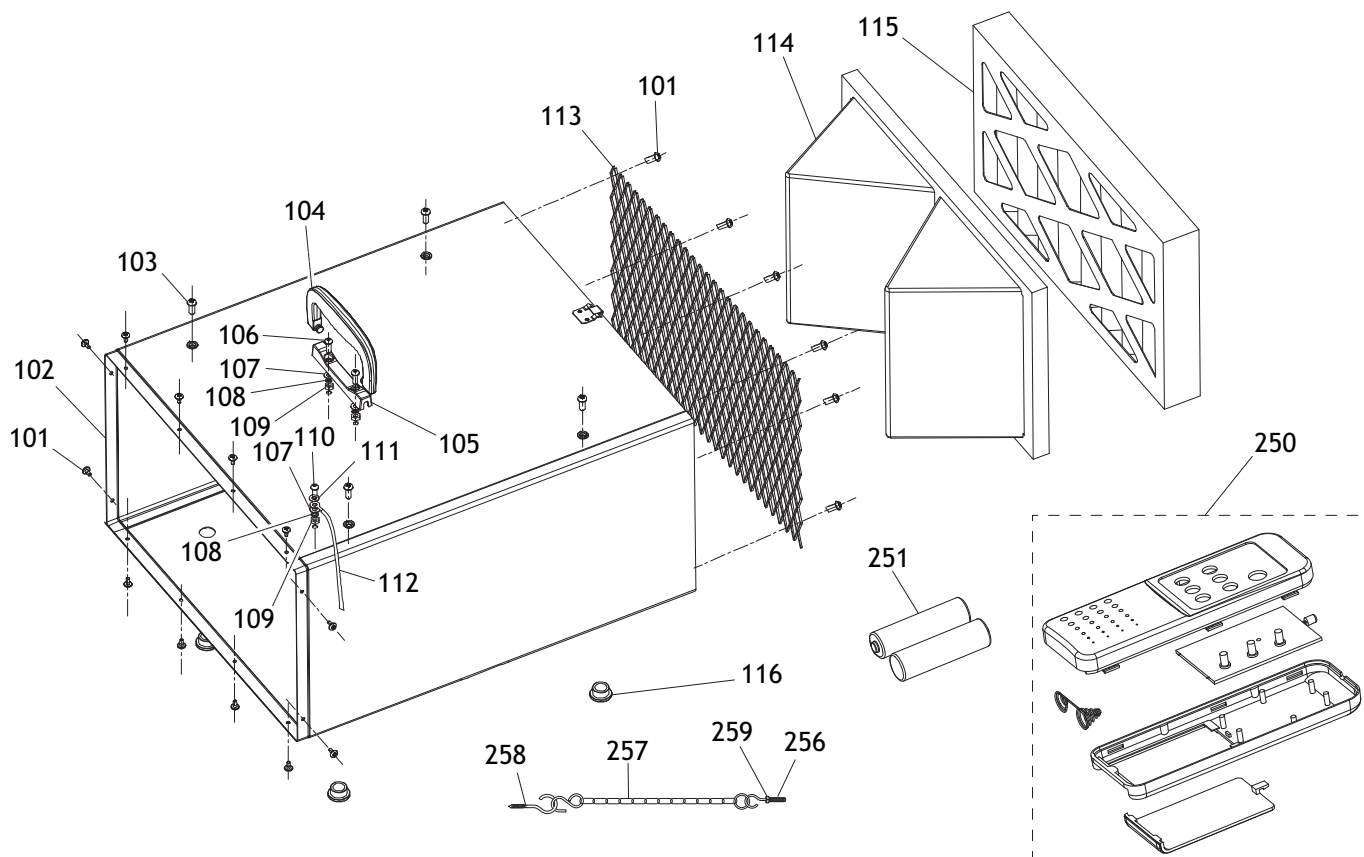

REF	PART #	DESCRIPTION
101	XPHTEK15M	TAP SCREW M4 X 10
102	X1830102	CABINET
103	XPS14M	PHLP HD SCR M6-1 X 12
104	X1830104	CABINET HANDLE
105	X1830105	HANDLE BRACKET
106	XPS40M	PHLP HD SCR M5-.8 X 16
107	XPW02M	FLAT WASHER 5MM
108	XPLW01M	LOCK WASHER 5MM
109	XPN06M	HEX NUT M5-.8
110	XPS08M	PHLP HD SCR M5-.8 X 12
111	XPTLW02M	EXT TOOTH WASHER 5MM

REF	PART #	DESCRIPTION
112	X1830112	GROUND WIRE 18AWG 335MM
113	X1830113	WIRE MESH 251 X 528MM
114	D3834	INNER FILTER 421 X 241 X 160MM
115	D3835	OUTER FILTER 421 X 241 X 45MM
116	X1830116	RUBBER FOOT
250	X1830250	REMOTE CONTROL UNIT
251	XPBATTAA	BATTERY AA
256	X1830256	THREADED HOOK M6-1 X 35
257	X1830257	HANGING CHAIN 11-1/2"
258	X1830258	HOOK SCREW M6 X 25
259	XPFN02M	FLANGE NUT M6-1

Control Panel

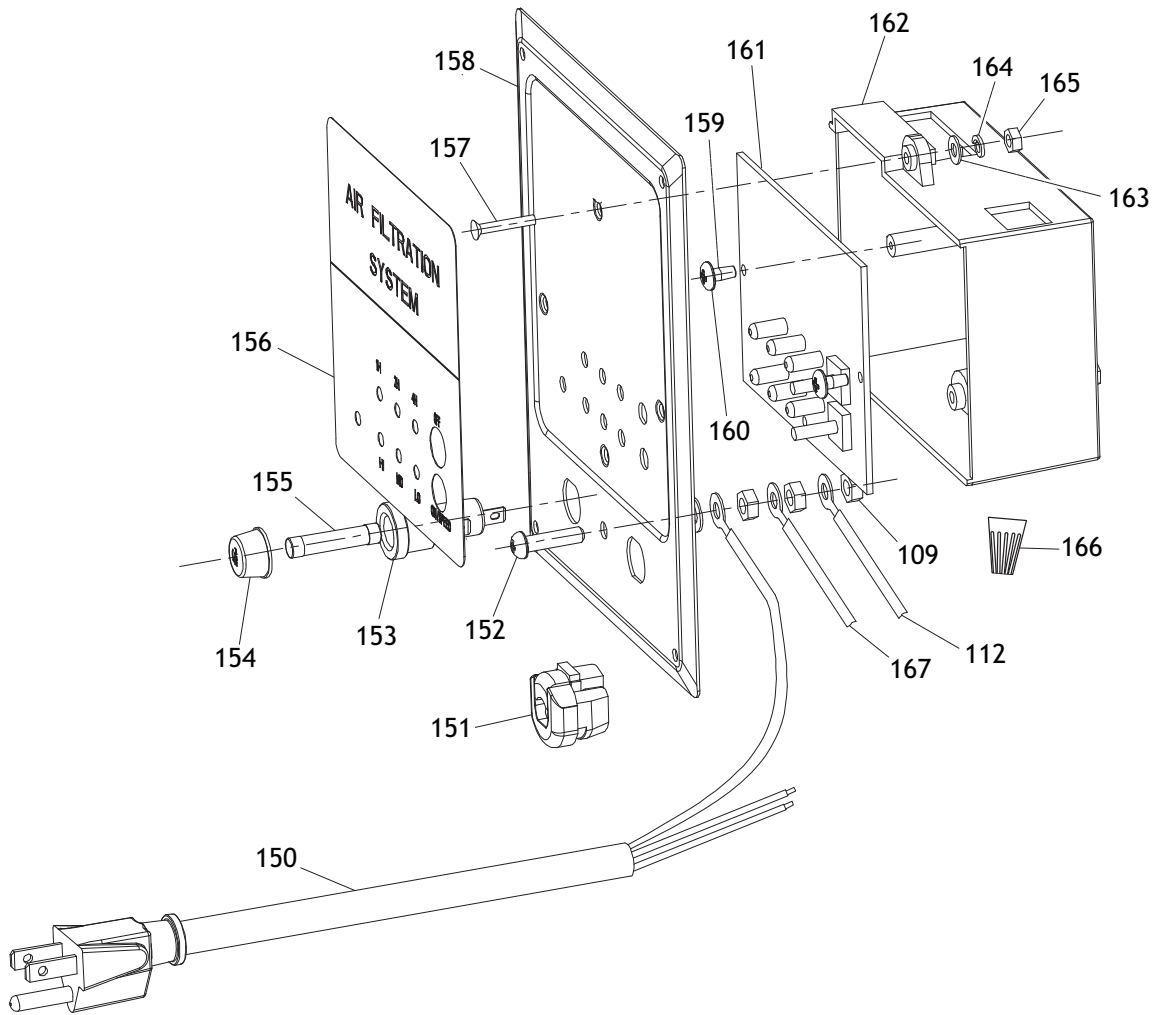

REF	PART #	DESCRIPTION
109	XPN06M	HEX NUT M5-.8
112	X1830112	GROUND WIRE 18AWG 335MM
150	X1830150	POWER CORD 18G 3W 72" 5-15
151	X1830151	STRAIN RELIEF 6P-4
152	XPS06M	PHLP HD SCR M5-.8 X 20
153	X1830153	FUSE HOLDER CFH052S CR3-13
154	X1830154	FUSE HOLDER CAP
155	X1830155	FUSE F2A250V
156	X1830156	CONTROL PANEL LABEL
157	XPFH85M	FLAT HD SCR M3-.5 X 30

REF	PART #	DESCRIPTION
158	X1830158	CONTROL PANEL PLATE
159	X1830159	INSULATED FLAT WASHER 3MM
160	XPHTK31M	TAP SCREW M4 X 14
161	X1830161	PRINTED CIRCUIT BOARD
162	X1830162	CONTROL PANEL BOX
163	XPW07M	FLAT WASHER 3MM
164	XPLW09M	LOCK WASHER 3MM
165	XPN07M	HEX NUT M3-.5
166	X1830166	WIRE NUT 18G
167	X1830167	WIRE 18G 6-3/4"

Motor & Impeller

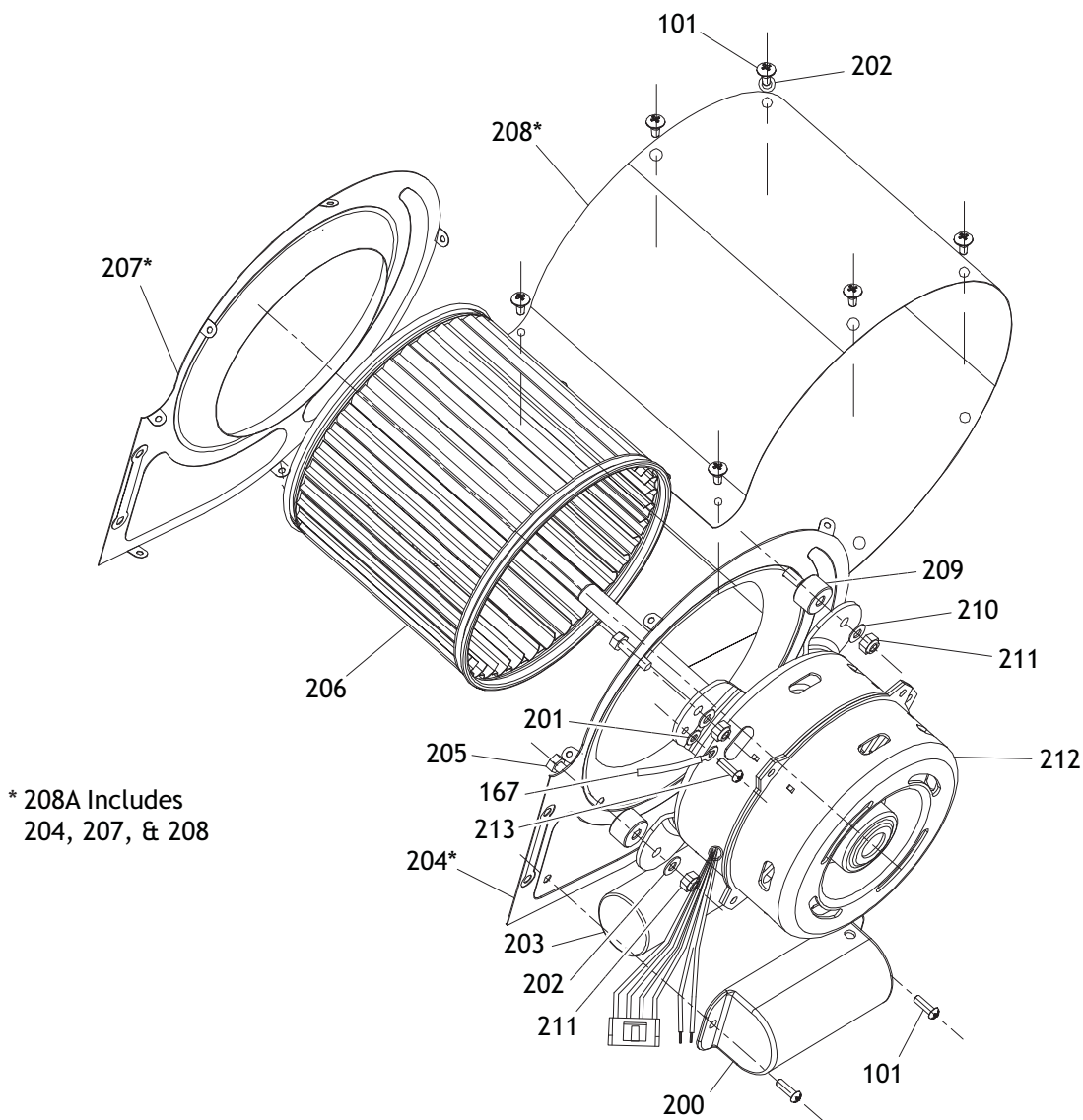

REF	PART #	DESCRIPTION
101	XPHTEK15M	TAP SCREW M4 X 10
167	X1830167	WIRE 18G 6-3/4"
200	X1830200	CAPACITOR COVER
201	XPTLW01M	EXT TOOTH WASHER 4MM
202	XPW02M	FLAT WASHER 5MM
203	X1830203	R CAPACITOR 8M 375V 1-1/4 X 2-1/2
204	X1830204	FRONT IMPELLER HOUSING COVER
205	XPB94M	HEX BOLT M5-.8 X 25
206	X1830206	SQUIRREL CAGE IMPELLER

REF	PART #	DESCRIPTION
207	X1830207	REAR IMPELLER HOUSING COVER
208A	X1830208A	IMPELLER HOUSING ASSEMBLY
208	X1830208	IMPELLER HOUSING
209	X1830209	RUBBER SPACER
210	XPWF05M	FENDER WASHER 5MM
211	XPLN02M	LOCK NUT M5-.8
212	X1830212	MOTOR 1/8HP 120V 60HZ
213	XPS02M	PHLP HD SCR M4-.7 X 12

Label Placement

⚠️ WARNING

Safety labels warn about machine hazards and how to prevent serious personal injury. The owner of this machine **MUST** maintain the original location and readability of all labels on this machine. If any label is removed or becomes unreadable, **REPLACE** that label before allowing machine to be operated again. Contact us at (360) 734-3482 or www.shopfoxtools.com to order new labels.

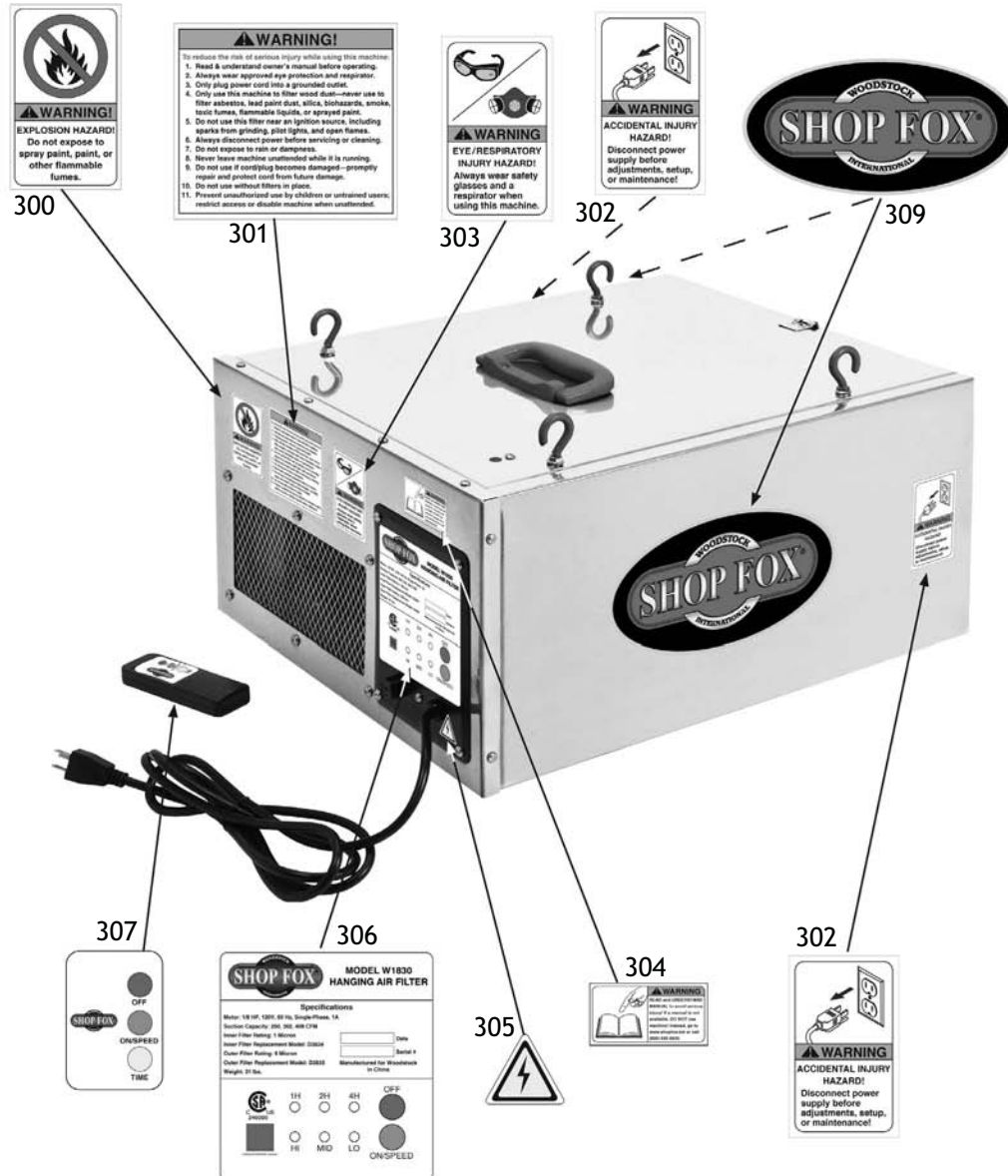

REF	PART #	DESCRIPTION
300	X1830300	EXPLOSION HAZARD LABEL
301	X1830301	GENERAL WARNINGS LABEL
302	XLABEL-24	DISCONNECT LABEL
303	XLABEL-06	EYE/LUNG HAZARD LABEL
304	XLABEL-08A	READ MANUAL LABEL

REF	PART #	DESCRIPTION
305	XLABEL-04	ELECTRICITY LABEL
306	X1830306	CONTROL PANEL LABEL
307	X1830307	REMOTE CONTROL LABEL
309	X1830309	SHOP FOX LABEL



Warranty Registration

Name _____
 Street _____
 City _____ State _____ Zip _____
 Phone # _____ Email _____ Invoice # _____
 Model # _____ Serial # _____ Dealer Name _____ Purchase Date _____

The following information is given on a voluntary basis. It will be used for marketing purposes to help us develop better products and services. Of course, all information is strictly confidential.

- How did you learn about us?

<input type="checkbox"/> Advertisement	<input type="checkbox"/> Friend	<input type="checkbox"/> Local Store
<input type="checkbox"/> Mail Order Catalog	<input type="checkbox"/> Website	<input type="checkbox"/> Other:
- How long have you been a woodworker/metalworker?

<input type="checkbox"/> 0-2 Years	<input type="checkbox"/> 2-8 Years	<input type="checkbox"/> 8-20 Years	<input type="checkbox"/> 20+ Years
------------------------------------	------------------------------------	-------------------------------------	------------------------------------
- How many of your machines or tools are Shop Fox?

<input type="checkbox"/> 0-2	<input type="checkbox"/> 3-5	<input type="checkbox"/> 6-9	<input type="checkbox"/> 10+
------------------------------	------------------------------	------------------------------	------------------------------
- Do you think your machine represents a good value? Yes No
- Would you recommend Shop Fox products to a friend? Yes No
- What is your age group?

<input type="checkbox"/> 20-29	<input type="checkbox"/> 30-39	<input type="checkbox"/> 40-49
<input type="checkbox"/> 50-59	<input type="checkbox"/> 60-69	<input type="checkbox"/> 70+
- What is your annual household income?

<input type="checkbox"/> \$20,000-\$29,000	<input type="checkbox"/> \$30,000-\$39,000	<input type="checkbox"/> \$40,000-\$49,000
<input type="checkbox"/> \$50,000-\$59,000	<input type="checkbox"/> \$60,000-\$69,000	<input type="checkbox"/> \$70,000+
- Which of the following magazines do you subscribe to?

<input type="checkbox"/> Cabinet Maker	<input type="checkbox"/> Popular Mechanics	<input type="checkbox"/> Today's Homeowner
<input type="checkbox"/> Family Handyman	<input type="checkbox"/> Popular Science	<input type="checkbox"/> Wood
<input type="checkbox"/> Hand Loader	<input type="checkbox"/> Popular Woodworking	<input type="checkbox"/> Wooden Boat
<input type="checkbox"/> Handy	<input type="checkbox"/> Practical Homeowner	<input type="checkbox"/> Woodshop News
<input type="checkbox"/> Home Shop Machinist	<input type="checkbox"/> Precision Shooter	<input type="checkbox"/> Woodsmith
<input type="checkbox"/> Journal of Light Cont.	<input type="checkbox"/> Projects in Metal	<input type="checkbox"/> Woodwork
<input type="checkbox"/> Live Steam	<input type="checkbox"/> RC Modeler	<input type="checkbox"/> Woodworker West
<input type="checkbox"/> Model Airplane News	<input type="checkbox"/> Rifle	<input type="checkbox"/> Woodworker's Journal
<input type="checkbox"/> Modeltec	<input type="checkbox"/> Shop Notes	<input type="checkbox"/> Other:
<input type="checkbox"/> Old House Journal	<input type="checkbox"/> Shotgun News	

9. Comments: _____

CUT ALONG DOTTED LINE

FOLD ALONG DOTTED LINE

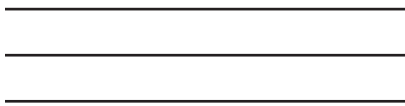

Place
Stamp
Here



WOODSTOCK INTERNATIONAL INC.
P.O. BOX 2309
BELLINGHAM, WA 98227-2309



FOLD ALONG DOTTED LINE

TAPE ALONG EDGES--PLEASE DO NOT STAPLE

WARRANTY

Woodstock International, Inc. warrants all Shop Fox machinery to be free of defects from workmanship and materials for a period of two years from the date of original purchase by the original owner. This warranty does not apply to defects due directly or indirectly to misuse, abuse, negligence or accidents, lack of maintenance, or reimbursement of third party expenses incurred.

Woodstock International, Inc. will repair or replace, at its expense and at its option, the Shop Fox machine or machine part, which in normal use has proven to be defective, provided that the original owner returns the product prepaid to a Shop Fox factory service center with proof of their purchase of the product within two years, and provides Woodstock International, Inc. reasonable opportunity to verify the alleged defect through inspection. If it is determined there is no defect, or that the defect resulted from causes not within the scope of Woodstock International Inc.'s warranty, then the original owner must bear the cost of storing and returning the product.

This is Woodstock International, Inc.'s sole written warranty and any and all warranties that may be implied by law, including any merchantability or fitness, for any particular purpose, are hereby limited to the duration of this written warranty. We do not warrant that Shop Fox machinery complies with the provisions of any law or acts. In no event shall Woodstock International, Inc.'s liability under this warranty exceed the purchase price paid for the product, and any legal actions brought against Woodstock International, Inc. shall be tried in the State of Washington, County of Whatcom. We shall in no event be liable for death, injuries to persons or property or for incidental, contingent, special or consequential damages arising from the use of our products.

Every effort has been made to ensure that all Shop Fox machinery meets high quality and durability standards. We reserve the right to change specifications at any time because of our commitment to continuously improve the quality of our products.



High Quality Machines and Tools

Woodstock International, Inc. carries thousands of products designed to meet the needs of today's woodworkers and metalworkers. Ask your dealer about these fine products:

BROSENA
PRECISION STOP BLOCK

JOINTER PAL[®]

Rotacator[®]

THE REBEL[®]

DURASTICK[®]

Gutmann[®]

BOARD BUDDIES[®]



Junglee[®]

PLANER PAL[®]

PARROT VISE[®]

SLICKPLANE[®]

PRO-STIK[®]
ABRASIVE BELT & DISC CLEANER

ACCU-SHARP[®]

Aluma-Classic[®]



STEELEX[®]
FINE TOOLS

STEELEX[®]
PLUS



WHOLESALE ONLY

WOODSTOCK INTERNATIONAL, INC.

Phone: (360) 734-3482 • Fax: (360) 671-3053 • Toll Free Fax: (800) 647-8801

P.O.Box 2309 • Bellingham, WA 98227

SHOPFOX.BIZ