

KENWOOD

KRC-X858
KRC-708

CASSETTE RECEIVER

INSTRUCTION MANUAL

AMPLI-TUNER-LECTEUR DE CASSETTE

MODE D'EMPLOI

RADIO CASSETTE

MANUAL DE INSTRUCCIONES

KENWOOD CORPORATION

Take the time to read through this instruction manual.

Familiarity with installation and operation procedures will help you obtain the best performance from your new cassette-receiver.

For your records

Record the serial number, found on the back of the unit, in the spaces designated on the warranty card, and in the space provided below. Refer to the model and serial numbers whenever you call upon your KENWOOD dealer for information or service on the product.

Model KRC-X858/708 Serial number _____

Contents

Before use

Safety precautions	3
--------------------------	---

General features

Power	5
Switching Modes	6
Volume	6
Attenuator	6
Loudness	6
Audio Control Setting	7
Mobile Preset	9
Switching Display	10
Non-Fading Output	10
Forced Closing	10
Removing the Faceplate	12
Faceplate Angle Adjustment	13

Tuner features

Tuning	14
Station Preset Memory	14
Auto Memory Entry	14
Station Name Preset (SNPS)	15
Station Name Preset Play (SNPP)	16
Switching Display for Tuner	16

RDS features (KRC-X858 only)

RDS (Radio Data System)	17
Alarm	17
Radio Text Scroll	17
Program Type (PTY) Function	18
Registration of a station as a PTY	19

Cassette player features

Playing Cassette Tapes	20
Fast Forwarding and Rewinding Cassette Tapes	20
Using Dolby B Noise Reduction	20
Switching Tape Types	20
Using Direct Program Search System (DPSS)	20
Blank Skip	21
Music Repeat	21
Tape counter display	22

External disc control features

Playing Disc mode	23
Switching Display for Discs	24
Fast Forwarding and Reversing Disc Play	24
Track Search	24
Disc Search	24
Direct Track Search	25
Direct Disc Search	25
Presetting Disc Names (DNPS)	26
Track / Disc Repeat	27

Track Scan	27
Disc Scan	27
Disc Name Preset Play (DNPP)	26
Random Play	28
Magazine Random Play	28
Text / Title Scroll	29

Menu setting

Menu System	30
Touch Sensor Tone	30
Manual Time Adjusting	30
Calendar Adjusting	30
Calendar Mode	31
Memo Mode	32
Automatic Time Adjusting	32
Manual Open Button Setting	33
Traffic Information Function	33
Clean Reception Circuit (CRSC)	33
Text Scroll	33
Security Code	34
Selectable Illumination	35
Contrast Adjustment	35
Dimmer	35
Switching Graphic Display	35
Black Mask	35
Time setting for removing the faceplate	35
Switching preout	35
Dual Zone System	36
KEX/ec4/dB (Sound Coordinate system)	36
External Amp Control	36

Basic operations of remote37

Installation

Accessories	40
Installation Procedure	40
Connecting Wires to Terminals	41
Installation (non-Japanese cars)	42
Locking the faceplate to the unit	42
Removing the Unit	43
Installation (Japanese-cars)	44

Troubleshooting guide45

Specifications48

Safety precautions

▲WARNING

To prevent injury or fire, take the following precautions:

- Insert the unit all the way in until it is fully locked in place. Otherwise it may fall out of place when jolted.
- When extending the ignition, battery, or ground wires, make sure to use automotive-grade wires or other wires with a 0.75mm² (AWG18) or more to prevent wire deterioration and damage to the wire coating.
- To prevent a short circuit, never put or leave any metallic objects (such as coins or metal tools) inside the unit.
- If the unit starts to emit smoke or strange smells, turn off the power immediately and consult your Kenwood dealer.
- Make sure not to get your fingers caught between the faceplate and the unit.
- Be careful not to drop the unit or subject it to strong shock.
The unit may break or crack because it contains glass parts.
- Do not touch the liquid crystal fluid if the LCD is damaged or broken due to shock. The liquid crystal fluid may be dangerous to your health or even fatal.
If the liquid crystal fluid from the LCD contacts your body or clothing, wash it off with soap immediately.

▲CAUTION

To prevent damage to the machine, take the following precautions:

- Make sure to ground the unit to a negative 12V DC power supply.
- Do not open the top or bottom covers of the unit.
- Do not install the unit in a spot exposed to direct sunlight or excessive heat or humidity. Also avoid places with too much dust or the possibility of water splashing.
- Do not subject the faceplate to excessive shock, as it is a piece of precision equipment.
- When replacing a fuse, only use a new one with the prescribed rating. Using a fuse with the wrong rating may cause your unit to malfunction.
- To prevent a short circuit when replacing a fuse, first disconnect the wiring harness.
- Do not place any object between the faceplate and the unit.
- Do not use your own screws. Use only the screws provided. If you use the wrong screws, you could damage the unit.
- Do not apply excessive force to the moving faceplate. Doing so will cause damage or malfunction.
- Do not apply excessive force to the open faceplate or place objects on it. Doing so will cause damage or breakdown.

IMPORTANT INFORMATION

You cannot connect the unit directly to the following CD automatic changers. If you want to use older changers with the unit, follow the directions below according to the type of changer you own:

• KDC-C200 / KDC-C300 / KDC-C400

Use the extension cable and the control box attached to the CD changer, and the optional CA-DS100 converter cord.

• KDC-C301 / KDC-C600 / KDC-C800 / KDC-C601 / KDC-C401

Use the extension cable attached to the CD changer, and the optional CA-DS100 converter cord.

• KDC-C100 / KDC-C302 / C205 / C705 / non-Kenwood CD changers

Cannot be used with this model.

▲CAUTION

You can damage both your unit and the CD changer if you connect them incorrectly.

FCC WARNING

This equipment may generate or use radio frequency energy. Changes or modifications to this equipment may cause harmful interference unless the modifications are expressly approved in the instruction manual. The user could lose the authority to operate this equipment if an unauthorized change or modification is made.

Safety precautions

NOTE

- If you experience problems during installation, consult your Kenwood dealer.
- If the unit fails to operate properly, press the RESET button. When the faceplate controls are not visible, press the left part at the upper side of the faceplate (as illustrated on p.11) for as many times as you have preset to make the faceplate controls appear. The unit returns to factory settings when the RESET button is pressed. If the unit still fails to operate properly after the RESET button has been pressed, contact your local KENWOOD dealer for assistance.
- Press the reset button if the disc auto changer is first controlled and operates incorrectly. The original operating condition will return.

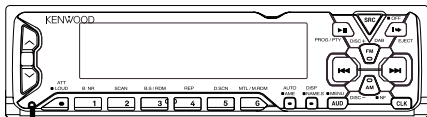

Reset button

- We recommend the use of the Security Code function (see p.34) to prevent theft.
- Characters in the LCD may become difficult to read in temperatures below 41 °F (5 °C).

- The illustrations of the display and the panel appearing in this manual are examples used to explain more clearly how the controls are used. Therefore, what appears on the display in the illustrations may differ from what appears on the display on the actual equipment, and some of the illustrations on the display may represent something impossible in actual operation.
- The functions that can be used and the information that can be displayed will differ depending on the external disc players being connected.

Cleaning the Faceplate Terminals

If the terminals on the unit or faceplate get dirty, wipe them with a dry, soft cloth.

Cleaning the Unit

If the front panel gets dirty, turn off the power and wipe the panel with a dry silicon cloth or soft cloth.

CAUTION

Do not wipe the panel with a hard cloth or a cloth dampened by volatile solvents such as paint thinner and alcohol. They can scratch the surface of the panel and/or cause the indicator letters to peel off.

*Dolby noise reduction manufactured under license from Dolby Laboratories Licensing Corporation.
"DOLBY" and the double-D symbol are trademarks of Dolby Laboratories Licensing Corporation.*

Cleaning the Tape Head

After you have listened to many cassettes over a long period of time, magnetic powder from the tapes and dust accumulates on the tape head, causing noise and a deterioration in sound quality. Clean the tape head using a cleaning tape or cleaning kit designed for use in car audio systems.

Handling Cassette Tapes

- Do not play a cassette whose tape has gone slack. In such a case, wind it tight using a pencil or the like in one of the spools. Playing slack cassette tapes can result in the tape tangling around the capstan and/or pinch rollers, causing trouble.
- Do not play a deformed cassette or one whose label is starting to come off, as it can cause the unit to malfunction.
- Do not leave tapes in hot places, such as on dashboards and other spots exposed to direct sunlight, or near heater outlets. They can deform the cassette.
- Avoid using extremely long cassette tapes, such as 100-minute-long tapes. Such tapes are very thin, and can tangle easily around the pinch rollers or other parts inside the unit, causing unit failure.
- Remove a cassette tape from the unit when not listening to it for a while. If you leave a tape in the unit too long, it may stick to the tape head and cause unit malfunction.

General features

Switching Modes

Switching Modes:

Each time you press the SRC (source) button, the mode switches as follows:

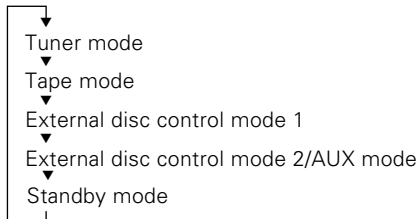

Selecting standby mode:

Press the SRC button repeatedly and switch to "ALL OFF". When "ALL OFF" is displayed, the standby mode is activated. The standby mode turns all functions off while leaving the power to the unit on. Use this mode when you want to have the display illuminated but don't want to listen to anything.

NOTE

- The mode switches to the next mode from any mode which cannot be used.
- The external disc control mode will differ depending on the unit that is connected.
- The AUX mode is available only when the changer / AUX switching adapter (KCA-S210A or CA-C1AX) or CD changer (KDC-CPS85, KDC-CX85, KDC-CPS82 or KDC-CX82) is connected to this unit.

During the AUX mode, "AUX" / AUX-name will show in the display. When the CA-C1AX is being used, the AUX Mode will replace the External Disc Control Mode.

NOTE Presetting AUX-name

In the AUX mode, press the NAME.S button for at least two seconds. "NAME SET" is display and AUX-name mode is entered. Input the characters, referring to the section on "Presetting Disc Names (DNPS)" (page26).

Volume

Increasing Volume:

Press the \wedge button to turn up the volume.

Decreasing Volume:

Press the \vee button to turn down the volume.

Attenuator

This function allows you to turn down the volume quickly.

Turning Attenuator On/Off:

Press the ATT button to switch the attenuator on and off.

When the attenuator is on, the ATT indicator blinks.

When the attenuator is off, the volume returns to the original level.

NOTE

Turning the volume up, or turning it all the way down deactivates the attenuator function.

Loudness

This function amplifies low and high tones when the volume is turned down.

The LOUD indicator lights up when the loudness function is on.

Turning Loudness On/Off:

Press the LOUD button for at least one second to switch the loudness on and off.

NOTE

The loudness function does not affect non-fading pre-out.

Audio Control Setting

Adjust various parameters of sound quality.

1 Press the AUD button to enter the control mode.

2 **Selecting mode**

Press either the FM or AM button.

Each time the button is pressed, the adjustment mode will change.

Please refer to the following for the contents of the adjustment modes.

NOTE Source tone memory

Each source (tape, CD, FM, AM and disc changer) has its own memory in which to store the bass, treble and N-F level settings. The settings made for a particular source are recalled automatically whenever you use that source (for example, FM mode uses the tone settings made for FM, AM for AM, etc.).

3 **Adjust each mode**

Press the \lll/\ggg button.

Please refer to the following for the adjusting values.

4 Press the AUD button to end the control mode.

"Kex"/"ec4"/"dB" : Recalling the kenwood preset sound setting

Press the preset buttons (#1-6).

Settings: #1;Flat, #2;Rock, #3;Pops/Top40, #4;Jazz, #5;Easy, #6;Scan of #1-5

NOTE

- This mode is available only when the Sound coordinate system is on. (page36)
- You can call the following settings with this function; bass center frequency, bass level, bass quality factor, bass extension, treble center frequency, and treble level setting. Their setting values are different depending on the setting of the mobile preset plan mode.

Function of the KRC-X858

"Bass F" : Adjust the center frequency of the bass.

Setting values: 60 / 70 / 80 / 100 (Only when the bass quality factor is set to 1.00, 1.25 or 1.50) / 150 (Only when the bass quality factor is set to 2.00) Hz

NOTE

This mode is available only when the Sound coordinate system is on. (page36)

"Bass" : Adjust the bass level.

Setting values: - 8 - + 8

Function of the KRC-X858

"Bass Q" : Adjust the Bass quality factor.

Setting values: 1.00 / 1.25 / 1.50 / 2.00

NOTE

This mode is available only when the Sound coordinate system is on. (page36)

Function of the KRC-X858

"Bass EXT" : Switch the Bass Extend mode on/off.

Setting values: ON / OFF

(When the bass extend mode is set to on, low frequency response is extended by 20%.)

NOTE

This mode is available only when the Sound coordinate system is on. (page36)

General features

Function of the KRC-X858

"Tre F" : Adjust the center frequency of the treble.

Setting values: 10.0 / 12.5 / 15.0 / 17.5 kHz

NOTE

This mode is available only when the Sound coordinate system is on. (page36).

"Treble" : Adjust the treble level.

Setting values: - 8 – + 8

"Balance" : Adjust the balance level.

Setting values: Left 15 – Right 15

"Fader" : Adjust the fader level.

Setting values: Front 15 – Rear 15

Function of the KRC-X858

"NF Level" : Adjust the Non-fading output level.

Setting values: - 15 – + 15

NOTE

- This mode is available only when the non-fading output function is set to on.(page10).
- Not available during the Dual zone system is on.

Function of the KRC-X858

"HPF F" : Adjust the frequency of the High-pass filter for front output.

Setting values: Through / 40Hz / 60Hz / 80Hz / 100Hz / 120Hz / 150Hz / 180Hz / 220Hz

NOTE

You can separately set the high-pass filter for front and rear output,including preouts.The high-pass filter works except during non-fading preout when switching to non-fading.The factory default settings for front output and rear output are "Through" .

Function of the KRC-X858

"HPF R" : Adjust the frequency of the High-pass filter for rear output.

Setting values: Through / 40Hz / 60Hz / 80Hz / 100Hz / 120Hz / 150Hz / 180Hz / 220Hz

NOTE

You can separately set the high-pass filter for front and rear output,including preouts. The high-pass filter works except during non-fading preout when switching to non-fading. The factory default settings for front output and rear output are "Through" .

Function of the KRC-X858

"LPF NF" : Adjust the frequency of the Low-pass filter for Non-Fading output.

Setting values: 50 Hz / 80 Hz / 120 Hz / Through

NOTE

- This mode is available only when the non-fading output function is set to on.(page10).
- Not available during the Dual zone system is on.

Function of the KRC-X858

"NF Phase" : Adjust the phase for Non-Fading output.

Setting values: Normal (0°) / Reverse (180°)

NOTE

- This mode is available only when the non-fading output function is set to on.(page10).
- Not available during the Dual zone system is on.

"V OFFSET" : Set the sound level of the each source selected by adjusting the level difference between the basic sound level and the required level.

Setting values: - 8 - 0

Function of the KRC-X858

Storing your sound settings:

Press a preset button (#1-6) for at least two seconds.

NOTE

- This setting can be made only when the Sound coordinate system is on.(page36).
- The settings you can preset are, bass center frequency, bass level, bass quality factor, bass extension, treble center frequency, and treble level.

Function of the KRC-X858

Recalling your sound settings:

Press a preset button (#1-6) except during the bass center frequency, bass level, bass quality factor, bass extension, treble center frequency, and treble level adjust mode.

NOTE

This mode is available only when Sound coordinate system is on.(page36).

Function of the KRC-708

Mobile Preset

This function allows you to adjust the setting that is recalled with the sound coordinate system, according to types of speakers.

- 1** Press the SRC button repeatedly to select the standby mode. "ALL OFF" is displayed when the standby mode is selected.
- 2** Press the AUD button to enter the mobile preset plan mode.
- 3** Press either the ◀◀ or ▶▶ button to select the type of speaker. The setting switches as follows.
OFF / For the OEM speaker / For 6/6x9 in. speaker / For 5/4 in. speaker
- 4** Press the AUD button to end the mobile preset plan mode.

NOTE

- This mode is available only when the Sound coordinate system is on. (page36)
- When you change the setting of type of speaker, the bass and treble tone settings are returned to original levels.

General features

Switching Display

You can change the display in each mode.

Changing the Display:

Each time you press the CLK button, the display switches as follows:

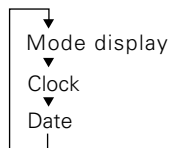

NOTE

The  indicator lights while the clock is displayed.

Function of the KRC-X858

Non-Fading Output

You can turn the non-fading output on and off while the preout is switched to the non-fading output.

Turning non-fading output On/Off :

Press the NF button for at least one second to set the function ON or OFF.

"NF ON" is displayed when the non-fading output is set ON.

Forced Closing

This function prevents tampering with the unit your car is being serviced etc.

Hiding the unit with the ignition turned on (forced closing):

Press the SRC button for at least one second.

The faceplate will slide open. When the period of time which you have set in the "Time setting for removing the faceplate" in the menu has passed, the faceplate automatically reverses to hide the control panel. However, you can remove the faceplate during that period. For details, refer to the "Removing the faceplate" (page12).

NOTE

- When the closing faceplate is hit by an object, the unit will turn off without the faceplate closing all the way. Remove the object and press the SRC button to turn the unit back on, then turn it off again to have it close properly.
- While the control panel is moving, pressing the buttons will not have any effect. Do not try to press the buttons on the control panel as the faceplate is moving, as excessive force may damage the unit.
- During the forced closing of the unit (i.e., having the unit left closed while ignition is turned on), the faceplate will not open no matter how often the ignition is turned on or off, unless "Manual Open button" at the rear of the faceplate is pressed in order to open it. You can prevent tampering of the unit when letting someone else drive your car by keeping it closed this way.

To cancel the forced closing of unit and open control panel:

Press the left part at the upper side of the faceplate for as many times as you have preset in the "Manual Open Button Setting" (OPEN SW #) in the menu. The faceplate will open and show the control panel.

NOTE

When you set the Manual Open Button setting to 2 or 3, press the upper left part of the faceplate without pausing. If you do not press that part without pausing, the command cannot be verified correctly.

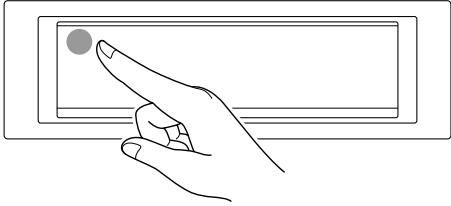

General features

Removing the Faceplate

The faceplate can be detached from the unit, helping to deter theft.

Removing the faceplate:

- 1 Choose the way from among the following and open the faceplate.
Turn the ignition off, press the SRC button for at least one second, or press the left part at the upper side of the faceplate (as illustrated on p.11) for as many times as you have preset in the "Manual Open Button Setting" (OPEN SW #) in the menu when the control panel has been hidden.
- 2 Set the faceplate's angle adjustment switch to "0" to set the faceplate angle to the vertical.
For details, refer to "Faceplate Angle Adjustment" (page 13).

NOTE

If the faceplate's angle adjustment switch is not set to "0" when mounting the faceplate on the faceplate bracket, it may be difficult to mount the faceplate or the faceplate may not be securely attached and could fall off.

Set the angle adjustment switch to "0" before removing the faceplate.

- 3 Slide the faceplate lock switch to the left during the period which you have set in the "Time setting for removing the faceplate" in the menu.

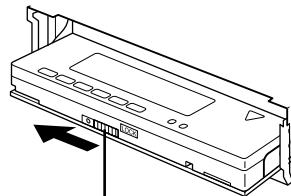

Faceplate lock switch

- 4 Holding the center part of the faceplate, pull it out.
The faceplate bracket will automatically close.

CAUTION

- When removing the faceplate, pull it out only when it is fully open. The detachment of the faceplate while it is moving might result in damage to the unit.
- Do not apply excessive force to the faceplate bracket without attaching the faceplate. Doing so will cause the faceplate bracket to be deformed.
- Do not touch the connector on the faceplate bracket after removing the faceplate. Touching the connector may cause damage to the unit.
- Do not touch two metal parts on both sides of the faceplate bracket. Touching those parts may injure you.

NOTE

- Sliding the faceplate lock switch cause the unit's power to turn off. If you want to operate the unit again, remove the faceplate from the faceplate bracket completely and then reattach it.
- The faceplate is a precision piece of equipment and can be damaged by shocks or jolts. For that reason, keep the faceplate in its special storage case while detached.
- Do not expose the faceplate or its storage case to direct sunlight or excessive heat or humidity. Also avoid places with too much dust or the possibility of water splashing.

Reattaching the Faceplate:

- 1 Hold the faceplate so that the control panel faces the front toward you and set the left side of the faceplate in the faceplate bracket.

CAUTION

Do not set the right side of the faceplate in the faceplate bracket first, when reattaching the faceplate. Doing so may cause the connector on the faceplate bracket to malfunction.

- 2 Press the right side of the faceplate until it locks.

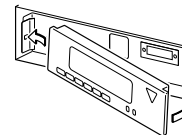

NOTE

If the faceplate bracket's angle was not set to the vertical when

the faceplate was mounted, check that the faceplate is securely attached to the faceplate bracket by holding its right side and pulling it gently towards you.

Faceplate Angle Adjustment

You can adjust the faceplate angle for easy viewing.

Adjusting faceplate angle:

Press the **EJECT** button to make the faceplate slide open, and then adjust the faceplate angle using the angle adjustment switch.

Adjustment may be made from 0 to 2.

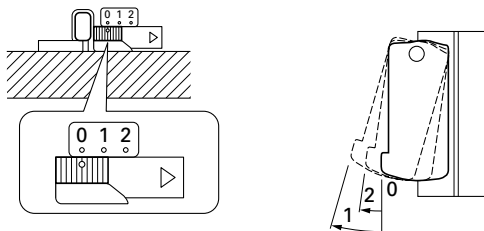

NOTE

- Firmly slide the switch until it clicks.
- Do not apply excessive force to the faceplate under settings 1 or 2.
- Set the angle adjustment switch to "0" before removing the faceplate.

Tuner features

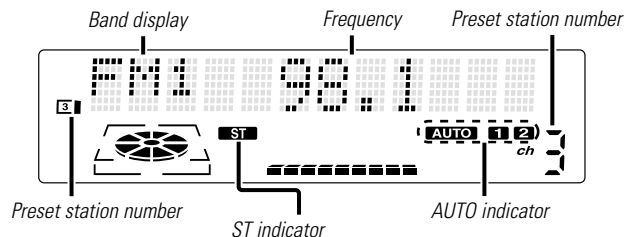
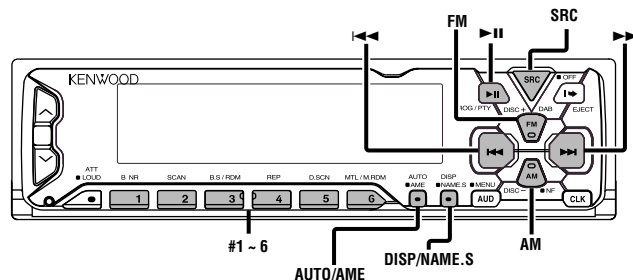

Tuner features

Tuning

You can choose from three tuning modes: auto seek, preset station seek, and manual. The "AUTO 1" indicator lights up when auto seek tuning is selected, and the "AUTO 2" indicator lights when preset station seek tuning is selected.

Selecting Tuning Mode:

Press the AUTO button.

Each time you press the AUTO button, the mode switches as follows.

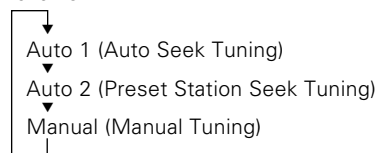

Tuning:

- 1 Press the SRC (source) button repeatedly to select the tuner mode. "TUNER" is displayed when the tuner mode has been selected.
- 2 Press either the FM or AM button to select the band. Each time you press the FM button, the band switches between the FM1, FM2 and FM3 (which are used for groups of preset stations). Press the AM button to select the AM band.
- 3
 - Auto Seek Tuning
Press the ►► button to seek higher frequencies.
Press the ◀◀ button to seek lower frequencies.
 - Preset station seek tuning
Press the ►► button to move to the next preset station (i.e., the one with the next highest number), and the ◀◀ button to move to the last preset station (i.e., the one with the next lowest number).
 - Manual Tuning
Press the ►► button to increase the frequency by one step.
Press the ◀◀ button to decrease the frequency by one step.

NOTE

The ST indicator lights up when stereo broadcasts are being

received.

Station Preset Memory

Store the frequency of a station. You can then recall that station with a single touch of a button.

- 1 Select the band/ station that you want to have stored.
- 2 Press the button (#1-6) that you want to use for the station, for at least two seconds.
The button number blinks once in the display to indicate that the data has been stored.

Recalling a Preset Station:

Press the preset station button (#1-6) for the desired station. The number of the recalled station is displayed.

NOTE

You can store six stations in each of the FM1, FM2, FM3, and AM bands.

Auto Memory Entry

You can automatically store all the receivable frequencies in the band currently being listened to, and then recall them with the touch of a button later. This function is especially useful when you are travelling and do not know what stations are available. Up to six frequencies can be stored this way.

- 1 Select the band for auto memory entry.
- 2 Press the AME button for at least two seconds to start auto memory entry.
The numbers of the preset station buttons are shown in order. When all the stations in a certain band are stored in the preset memory, the auto memory entry stops. The tuner then plays the last station received.

Recalling a Preset Station:

Press the preset station button (#1-6) for the desired station.
The number of the recalled station is displayed.

NOTE

- When the local seek function is turned while auto memory entry takes place, stations with poor reception are not stored.
- When the Traffic Information function is on, only the local traffic information station frequency will be stored.

Station Name Preset (SNPS)

You can assign names to radio stations with the Station Preset Memory. Up to 32 FM stations and 16 AM stations can be assigned names.

- 1 Adjust the frequency to the station whose name you want to enter.

NOTE

The station name preset function cannot be used when a program service name or radio text is displayed.

- 2 Press the NAME.S button for at least two seconds.
"NAME SET" is displayed once the station name preset mode is entered.
The cursor will blink in the position where letters are entered.
- 3 Press either the ◀◀ or ▶▶ button to move the cursor to the desired position.
The ◀◀ button moves the cursor to the left, and the ▶▶ button to the right.
- 4 Each time the ▶|| button is pressed, the characters to be entered change as listed below.
Press the FM or AM button to display the desired character.
Characters that can be displayed are as follows.

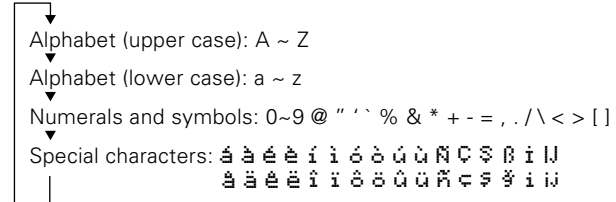

- 5 Continue steps 3 and 4 until all the characters are chosen for the name.

NOTE

You can enter up to 8 characters for each name.

6 Assigning Names

Press the NAME.S button.

The name of the station is stored in memory, and the Station Name Preset mode ends.

Also, if you make no input for 10 seconds, the name will be stored up to the point that you have entered, and the mode ends.

NOTE

- You can assign names to up to 32 FM stations and 16 AM stations.
- All the station names will be erased if you press the RESET button.
- If you want to change the name of a station, first display the name of the station (following steps 1 and 2 above), then change the letter(s) that you want by following steps 3 and 4.

Tuner features

Station Name Preset Play (SNPP)

(Function of Remote)

You can search for the station for any station if its name has been preset using Station Name Preset.

- 1 Press the DNPP button on the remote.
"SNPP" will be displayed once the station name preset play mode is entered.
The names of the stations stored in the band currently listened to are displayed in the following order for five seconds each:

→ FM1 ↔ FM2 ↔ FM3 ↔ AM ←

Each time you press the ►► button, the station display switches in the forward direction.

Each time you press the ◀◀ button, the station display switches in the reverse direction.

Stations whose names have not been stored will be displayed as frequencies.

NOTE Changing the Displayed Band

Pressing the FM button switches between the FM1, FM2, FM3 and AM displays, in that order.

Pressing the AM button switches between the displays in the reverse direction.

- 2 **Once the name is displayed for the station you want to listen to**

Press the OK button.

Reception starts of the displayed station, and the station name preset play mode ends.

Canceling mode during input:

Press the DNPP button.

The station name preset play mode is canceled.

Switching Display for Tuner

You can change the display used when listening to the radio.

Changing the Display:

Each time you press the DISP button, the display changes as follows:

Station frequency

SNPS name (only when being preset) /
Program Service name (during RDS station reception)
(KRC-X858 only)

Radio text (only during RDS station reception)
(KRC-X858 only)

NOTE (KRC-X858 only)

- When receiving an RDS station to which a name has been preset with Station Name Preset, switching to the program service name/SNPS name display will result in the program service name being displayed with priority.
- If the RDS station currently tuned to is transmitting no text while the Radio Text Display mode is turned on, "NO TEXT" will appear in the display. While awaiting reception, "WAITING" will be displayed.

▲WARNING

To prevent accidents, drivers should not look at the display while on the road.

RDS features

Function of the KRC-X858

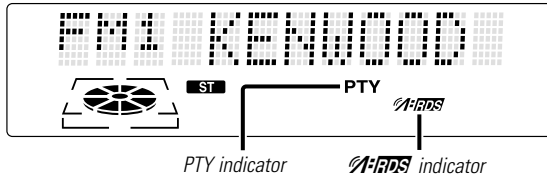
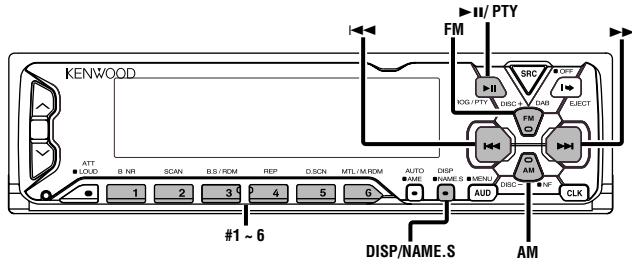

RDS (Radio Data System)

RDS is a service used by radio stations to transmit data outside normal radio broadcast signals.

When an RDS station is received, you can immediately find out what kind of data is being transmitted by looking at the program service name, which appears in the display after the frequency.

The **RDS** indicator turns on when an RDS station is being received.

Alarm

When an emergency transmission (announcing disasters, etc.) is made, the current function will be interrupted to allow the warning to be received under the following conditions: during tuner reception, or when the Traffic Information function is turned on.

Radio Text Scroll

This function permits the text to be scrolled and the entire text to be displayed. The scrolling method differs depending on the setting of scrolling in the menu.

To scroll automatically:

Press the DISP button to display the Radio Text. The display of the text will be scrolled repeatedly.

To scroll manually:

- 1 Press the DISP button to display the Radio Text.
- 2 Pressing the DISP button for at least one second results in one scrolling display of the text.

NOTE

Please see the menu settings (page33) about switching between manual scrolling and automatic scrolling.

RDS features

Function of the KRC-X858

Program Type (PTY) Function

Conduct auto seek tuning only on those stations with selected kinds of programs.

- 1 Press the ►|| (PTY) button.
"PTY" is displayed once the program type selection mode is entered.

NOTE

You cannot use this function while the traffic bulletin is received.

2 **Select the type of program to be received**

- Press either the FM or AM buttons repeatedly to select the type of program you want to listen to.

The selection includes:

	<i>Speech</i>	(<i>Speech</i>)
	<i>Music</i>	(<i>Music</i>)
1.	News	(NEWS)
2.	Information	(INFORM)
3.	Sports	(SPORTS)
4.	Talk	(TALK)
5.	Rock	(ROCK)
6.	Classic Rock	(CLS ROCK)
7.	Adult Hits	(ADLT HIT)
8.	Soft Rock	(SOFT RCK)
9.	Top 40	(TOP 40)
10.	Country	(COUNTRY)
11.	Oldies	(OLDIES)
12.	Soft	(SOFT)
13.	Nostalgia	(NOSTALGA)
14.	Jazz	(JAZZ)
15.	Classical	(CLASSICL)
16.	R&B	(R & B)
17.	Soft R&B	(SOFT R&B)
18.	Language	(LANGUAGE)
19.	Religious Music	(REL MUSC)
20.	Religious Talk	(REL TALK)
21.	Personality	(PERSNLTY)
22.	Public	(PUBLIC)

(*Speech*.....1~4, 18, 20~22, *Music*.....5~17, 19)

- You can select the type of program directly by pressing a preset button. The buttons are factory-set to the following

type of programs:

- | | | |
|-----------------|------------------|---------|
| 1. <i>Music</i> | 2. <i>Speech</i> | 3. News |
| 4. Sports | 5. Classical | 6. Jazz |

NOTE Changing the Preset Button Settings for Program Type
After selecting the type of program to be stored in a certain preset button, press that button for at least two seconds. The previously stored data for that button are erased and the new program type is stored.

3 **Seeking the Selected Program Type**

Press the ◀◀ or ▶▶ button to make a seek of frequencies with your selected type of program.

The display blinks and the seek starts.

"PTY" blinks in the display for about 30 seconds.

If you make no key input in 30 seconds, the PTY selection mode will turn off automatically.

NOTE

If no program can be found, "NO PTY" is displayed.

If you want to select another type of program, repeat steps 2 and 3 above.

Switching to Other Stations with the Same Type of Program:

When "PTY" is blinking in the display, perform auto seek tuning.

The tuner scans for another station with the same type of program.

Canceling Program Type Function During Its Operation:

Press the ►|| (PTY) button.

Confirming Program Type:

Press the DISP button.

The program type of the station currently tuned to will be displayed for five seconds. During that time, "E" will blink in the display.

NOTE

If you tune to frequencies for which no program type has been stored, "No Entry" will be displayed.

Cassette player features

Registration of a station as a PTY

You can register a station as a program type.

To register a non-RDS station as a program type:

- 1 Tune your radio to the non-RDS station that you want to register as the program type.
- 2 Press the PTY button to enter the program type selection mode.
- 3 Press the FM/AM button to select the program type you want to register. Follow the instructions in 2 to enter the program type selection mode.
- 4 Press the NAME.S button for at least two seconds. The station will be registered as a program type, allowing it to be the target of frequency seeks just as RDS stations are.
- 5 Press the PTY button to end the program type selection mode.

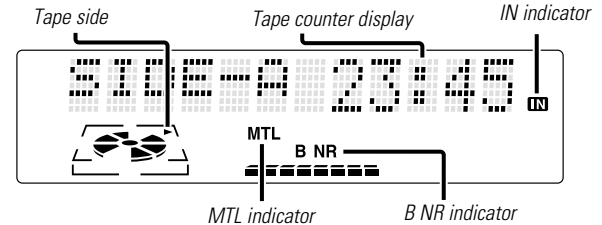
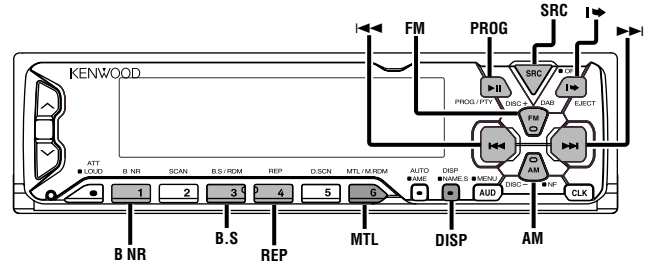

Cassette player features

Playing Cassette Tapes

Loading and Playing Cassettes:

Press the **EJECT** button to slide open the faceplate, showing the cassette (insertion) slot. Holding the cassette with the tape exposed to the right, insert in the slot. The faceplate will close, and the tape will start playing. The IN indicator lights up when a cassette has been loaded.

Playing Cassettes Already Loaded:

Press the SRC (source) button repeatedly to select the tape mode. "TAPE" is displayed when the tape mode has been selected. The tape will start playing.

Listening to the other side:

Press the PROG button. Tape play switches to the other side.

Eject:

Press the **EJECT** button to stop tape play. The faceplate will slide to eject the tape. Press the **EJECT** button to close the faceplate.

CAUTION

When the faceplate has been slid open, it might interfere with the shift lever or something else. If this happens, pay attention to safety and move the shift lever or take an appropriate action, then operate the unit.

NOTE

- The sound will be temporarily muted while the faceplate is moving.
- The only buttons that will work during the eject state are the **EJECT**, SRC, and ATT buttons, as well as the volume control button.
- Remove a cassette from the unit when not listening to it for a while. If you leave it in the unit too long, the tape may stick to the tape head and cause unit malfunction.

Fast Forwarding and Rewinding Cassette Tapes

Fast Forwarding Tapes:

Press the FM button.

Rewinding Tapes:

Press the AM button.

Canceling:

Press the PROG button. Normal tape play will begin.

Using Dolby B Noise Reduction

Listen to tapes recorded using Dolby B NR.

Turning Dolby B Noise Reduction On/Off:

Press the B NR button to switch Dolby B NR on and off. The B NR indicator lights up when it is turned on.

Switching Tape Types

Select type of tape being played.

Switching Tape Types:

Press the MTL (Metal) button to switch the metal tape indicator on and off and to select the tape type. Turn the MTL indicator off for normal tape (Type I) playback. Turn the MTL indicator on for the following tape types:
 CrO₂ (Type II) FeCr (Type III) Metal (Type IV)
 Selecting the wrong tape type may cause sound quality to suffer.

Using Direct Program Search System (DPSS)

Skip forward or backward to other tracks during playback.

Skipping to Beginning of Current Track or to Previous Tracks (Rewind DPSS):

Press the ◀◀ button.

Press once to rewind to the beginning of the current track, twice to rewind to the beginning of the previous track, and so forth.

You can skip up to nine tracks.

Playback is continued after the tape is rewound by the indicated number of tracks.

Skipping to Later Tracks (Fast Forward DPSS):

Press the ▶▶ button.

Press once to fast forward to the next track, twice to fast forward to the track after that, and so forth.

You can skip up to nine tracks.

Playback is continued after the tape is fast forwarded by the indicated number of tracks.

NOTE

- During the first five seconds of each track, the previous track is considered the "current" track. If you press the ◀◀ button during that period, the tape rewinds to the beginning of the previous track and not the one you are listening to.
- The DPSS function "knows" where a track begins by detecting the blank space preceding it (the space between tracks). However, when the blank space lasts for less than four seconds or contains noise, DPSS may not operate correctly. Furthermore, quiet intervals within a song are detected as "blank spaces" if they last for four seconds or more.

Canceling DPSS While It Is Operating:

Press the PROG button.

Blank Skip

Automatically fast forwards to the beginning of the next track when long blank spaces (10 seconds or more) are detected, continuing tape playback. This function is on, when unit is first powered on.

Turning Blank Skip Function On/Off:

Press the B.S button to switch the blank skip function on and off.
"B.Skip ON" is displayed when the blank skip function is turned on.

NOTE

- If the blank space contains much noise, the blank skip function may not work right.
- Sections recorded at low levels may trigger the blank skip function if they last for 10 seconds or more.

Music Repeat

Repeatedly plays the track currently being listened to.

Turning Music Repeat On/Off:

Press the REP button to switch music repeat on/off.
"Repeat ON" is displayed when music repeat is turned on.

Canceling Music Repeat:

Press either the REP or PROG button.

NOTE

Music repeat "knows" where a track begins by detecting the blank space preceding it (the space between tracks). However, when the blank space lasts for less than four seconds or contains noise, this function may not operate correctly. Furthermore, sections that are recorded at low levels may trigger the function if they last for four seconds or more.

Cassette player features

Tape counter display

Switching the Tape display :

Each time you press the DISP button, the display during tape play switches as follows:

- ↓
- Play side/Tape counter
- ↓
- Play side
- ↓
- Play side/Tape running

NOTE

The tape counter is not exact, but only represents an approximation of the elapsed time.

External disc control features

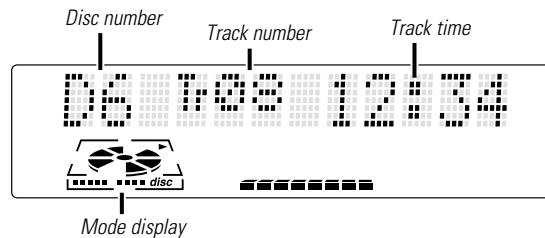
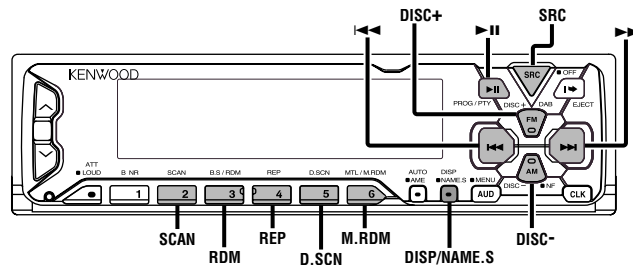

- When a unit equipped with an O-N switch is to be connected, please also see the instruction manual of this unit.

Set the O-N switch to "N". "N"-operation will be set.

"N"-operation:

- The disc title and track title of the CD text can be displayed.
- The disc name will be displayed when the name has been registered to any connected unit with the Presetting Disc Names function, or when the playing unit contains a disc to which the disc title has been recorded.

"O"-operation:

- CD text cannot be displayed.
- Regardless of the control unit, the characters that can be registered with the Presetting Disc Names function are "A~Z 0~9 /, +, -, *, =, <, >, [,]".
- The disc name will be displayed when the name has been registered to the playing unit with the Presetting Disc Names function.

NOTE

The CD text, Presetting Disc Names, and Disc Name Preset Play functions may not be operational depending on the unit.

- "CD" ...when a CD player is connected
- "DISC" ...when a disc changer is connected
- "DISC-1" , "DISC-2" ...when two disc changers are connected

Pausing and Restarting Disc Play:

Press the ►|| button to make the disc pause.
Press the same button again to start play again.

NOTE

- When one disc has finished playing its last track, the next disc in the changer starts playing. When the last disc in the changer has finished, the player returns to the first disc and starts playing it.
- Disc #10 is displayed as "0".

Playing Disc mode

This function permits the connection of optional players and the playing of discs.

Playing Discs:

Press the SRC button repeatedly to select the external disc control mode.

The disc will start playing.

NOTE

The external disc control mode will differ, depending on the unit that is connected.

Mode Display Examples

External disc control features

Switching Display for Discs

Switch the display that appears while discs are playing.

Switching Display for Discs:

Each time you press the DISP button, the display during disc play switches as follows.

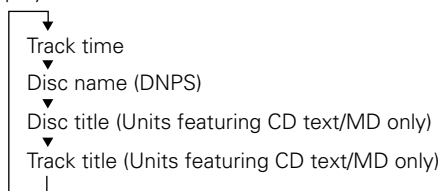

NOTE

- You can give names to discs through the presetting disc name function (see p. 26). Note that depending on the unit, display may not be possible.
- If you try to display the name of a disc that does not have one, "NO NAME" is displayed instead.
- When there is an attempt to display the title of a disc for which the disc title/track title has not been recorded, "NO TEXT" is displayed for CD and "NO TITLE/NO NAME" is displayed for MD.
- Depending on the type of characters of the CD Text, some characters may not be displayable.

Fast Forwarding and Reversing Disc Play

Fast Forwarding Disc Play:

Hold down on the ►► button.

Release your finger to play the disc at that point.

Reversing Disc Play:

Hold down on the ◀◀ button.

Release your finger to play the disc at the point.

NOTE

You cannot use reverse play between tracks depending on the model being connected. Instead, the reverse play function is canceled when it reaches the beginning of a track, at which point normal play will automatically resume.

Track Search

Search forward or backward through the tracks on the disc until you reach the one that you want to listen to.

Making a Reverse Track Search:

Press the ◀◀ button to display the desired track number.

Press once to search back to the beginning of the current track, twice to search back to the beginning of the previous track, and so forth.

Play starts at the beginning of the displayed track number.

NOTE

Pressing the ◀◀ button while listening to track 1 will only search back to the beginning of that track. The reverse search is not "recycled" to the last track on the disc.

Making a Forward Track Search:

Press the ►► button to display the desired track number.

Press once to fast forward to the next track, twice to fast forward to the track after that, and so forth.

Play starts at the beginning of the displayed track number.

NOTE

You cannot make a forward track search when listening to the last track on a disc.

Disc Search

(Function of disc changers)

Search forward or backward through the discs in a disc changer.

Making a Reverse Disc Search:

Press the DISC— button to display the desired disc number.

Each time the button is pressed, the displayed disc number decreases by one.

Play starts at the beginning of the displayed disc.

Making a Forward Disc Search:

Press the DISC+ button to display the desired disc number.

Each time the button is pressed, the displayed disc number increases by one.

Play starts at the beginning of the displayed disc.

NOTE

"LOAD" is displayed when discs are being exchanged on the disc changer.

Function of the KRC-X858

Direct Track Search

(Function of Remote)

Using the remote, directly input the track number that you want to listen to.

- 1 Using the number buttons on the remote, input the number of the track that you want to listen to.
The selected track number will blink in the display for 10 seconds.
If you make no further input in the 10-second period, the number entry mode will automatically be canceled.
- 2 Press either the ◀◀ or ▶▶ button while the track number is blinking.
The track starts playing.

Canceling Direct Track Search While It Is Operating:

Press the ▶|| button.

NOTE

You cannot use the direct track search function while doing track or disc scans or using random or magazine-random play.

Function of the KRC-X858

Direct Disc Search *(Function of disc changers with remote)*

Using the remote, directly input the disc number that you want to listen to.

- 1 Using the number buttons on the remote, input the number of the disc that you want to listen to.
The selected disc number will blink in the display for 10 seconds.
If you make no further input in the 10-second period, the number entry mode will automatically be canceled.

NOTE

- Input "0" to select disc 10.
 - If you input more than two numbers all at once, a search will be made only of the last number input.
- 2 Press either the DISC+ or DISC- button while the number inputted is blinking.
The disc starts playing.

Canceling Direct Disc Search While It Is Operating:

Press the ▶|| button.

External disc control features

Presetting Disc Names (DNPS)

Store the names of discs to be displayed when played.

- 1 Play the disc whose name you want to preset.

NOTE

- This function is not available for disc changers that do not feature the Disc Name Preset function.
 - This procedure is not to be used to store the disc and track titles for MDs that you record.
 - The disc name preset function cannot be used when a disc title name or track title is displayed.
- 2 Press the NAME.S button for at least two seconds. "NAME SET" is displayed and the disc name preset mode is entered. The cursor blinks in the position where character input can be made.
 - 3 Press either the ◀◀ or ▶▶ button to move the cursor to the desired position. The ◀◀ button moves the cursor to the left, and the ▶▶ button to the right. You can also move the cursor left or right by pressing the TRACK+ or TRACK- buttons, respectively, on the remote control.
 - 4 Each time the ▶|| button is pressed, the characters to be entered change as listed below. Press the DISC+ or DISC- button to display the desired character. Characters that can be displayed are as follows.

Alphabet (upper case): A ~ Z

Alphabet (lower case): a ~ z

Numerals and symbols: 0~9 @ " ' ` % & * + - = , . / \ < > []

Special characters: á à å ä é ê ë ì í î ï ò ó ô õ ö ù ü Ñ Ò Ó Ô Õ Ö Ù Ú Û Ü Ý Þ à á â ã

ä å æ ç è é ê ë ì í î ï ò ó ô õ ö ù ü

NOTE

The operation and characters that can be entered may change as listed below, depending on the unit that is connected. A press of the ▶|| button exits the disc name preset mode. Operations can be followed again from Step 2 at a time such as this, and the characters to be input are selected using the procedure described below. Press the DISC+ or DISC- button to display the desired character. Besides the alphabet (capital letters only) and numbers, you can choose the following characters: /, +, -, *, =, <, >, [and].

NOTE

Direct Alphabet Input (KRC-X858 only)

(Function of remote with number/letter entry buttons)

If the disc changers that were manufactured and sold after 1997 are connected (except for KDC-C560), you can directly input letters using the number/letter entry buttons on the remote. Example: Use the following table to enter the name "DANCE".

Character	Button to press	# Times pressed
"D"	#3	1
"A"	#2	1
"N"	#6	2
"C"	#2	3
"E"	#3	2

- 5 Continue steps 3 and 4 until all the characters are chosen for the name.
- 6 Press either the NAME.S button on the main unit or the OK button on the remote. The disc name is stored and the disc name preset mode is canceled. If you make no entry in a 10-second period, the name will be stored with the characters input so far.

NOTE

- The number of characters and discs whose names can be stored will differ depending on the disc changer that is

connected. Please see your disc changer manual for details.

- Discs are identified by their total length and number of tracks. If another disc happens to have the same specifications as one that you have already stored a name for, the name will be displayed for it, too.
- If you want to change the name of a disc, repeat steps 1 and 2 to display the name, and then repeat steps 3 and 4 to input the changes.
- Pressing the reset button does not erase the disc names stored in a disc changer.

Track / Disc Repeat

Repeat playing the track or the disc currently being listened to.

Turning Repeat Play On/Off:

Press the REP button to switch repeat track/disc play on and off as follows:

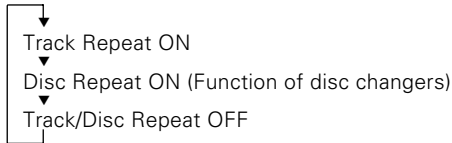

"T-Repeat/Repeat ON" is displayed and the track number blinks in the display when track repeat is on.

"D-Repeat ON" is displayed and the disc number blinks in the display when disc repeat is on.

NOTE

Repeat play is canceled when you eject the disc.

Track Scan

Successively play the beginning of each track on a disc until you find the track that you want to listen to.

Starting the Track Scan :

Press the SCAN button. "T-Scan/Scan ON" is displayed and the first 10 seconds of each track will be played, in order.

The track number currently being heard blinks in the display.

Starting to Listen to the Track Being Scanned:

Press the ►|| or SCAN button again to stop the scan and keep on listening to a track normally.

NOTE

- The track scan function is canceled when you eject the disc.
- The track scan function only scans each track on a disc once.

Disc Scan

(Function of disc changers)

Successively play the beginning of each disc on a changer until you find the one that you want to listen to.

Starting the disc scan:

Press the D.SCN button. "D-Scan ON" is displayed and the first 10 seconds of each disc will be played, in the order they are loaded on the changer.

The disc number currently being heard blinks in the display.

Starting to Listen to the Disc Being Scanned:

Press the ►|| or D.SCN button again to stop the scan and keep on listening to the disc normally.

NOTE

- The disc scan function is canceled when you eject the disc.
- The disc scan function only scans each disc on the changer once.
- "LOAD" is displayed when discs are being exchanged on the disc changer.

External disc control features

Disc Name Preset Play (DNPP)

(Function of Remote)

If you have preset the name of a disc that you want to listen to in the disc changer, you can look for it by name and start playing it.

- 1 Press the DNPP button on the remote.
"DNPP" will appear in the display, and the disc name preset play mode is entered.
The preset names/disc titles of the disc in the disc changer to which you are currently listening are successively displayed for five seconds each.
In any of the units that are connected, discs that have not been disc name preset will display "NO NAME".

NOTE

- This function can only be used in disc changers that were manufactured or sold as of 1997. Also note that some units cannot provide a display unless the disc name preset has been made by the unit that is playing.
- Discs in the disc changer that have never been played before will appear as "NO ACCES" when the disc names are displayed. When you cannot identify a disc because of the "NO ACCES" display after inserting a disc magazine, try playing it using the disc scan or a similar function to display the disc name. Also note that "NO DISC" will be displayed when a disc has not been loaded.

Rapid display (forward / reverse):

Press the DISC+ or DISC- button.
Pressing the DISC+ button will rapidly display the preset names/disc titles in order.
Pressing the DISC- button will rapidly display the preset names/disc titles in reverse order.

2 When the name appears for the disc you want to play

Press the OK button.
The disc whose name is displayed will be recalled, and the disc name preset play (DNPP) mode will end.

To cancel DNPP mode:

Press the DNPP button.
The disc name preset play (DNPP) mode will be canceled.

Random Play

Play all the tracks on the current disc in random order.

- 1 Press the RDM button to switch random play on and off.
"Random ON" is displayed when random play is turned on.
The track number will change over and over in the display as the next track is being selected.
When the track has been selected, play will begin.
The selected track number blinks in the display as it is being played.

NOTE

When all the tracks on a certain disc have been played using random play, the next disc on the changer will start playing using the same function.

- 2 To change the track being heard, press the ►► button.
Another track will be selected and played.

NOTE

Random play is canceled when you eject the disc.

Magazine Random Play (Function of disc changers)

Play the tracks on all the discs in the disc changer in random order.

- 1 Press the M.RDM button to switch magazine random play on and off.
"M-Random ON" is displayed when magazine random play is turned on.
The disc and track numbers will change over and over in the display as the next track is being selected.
When the disc/track has been selected, play will begin.
The selected disc/ track number blinks in the display as it is being played.

NOTE

This function is not available with the following models:
KDC-C200/C300/C400/C301/C401

Menu settings

- 2 To change the track being heard, press the ►► button.
Another disc/track will be selected and played.

NOTE

- Magazine random play is canceled when you eject the disc.
- The time needed for random selection depends on the number of discs loaded in the disc magazine.

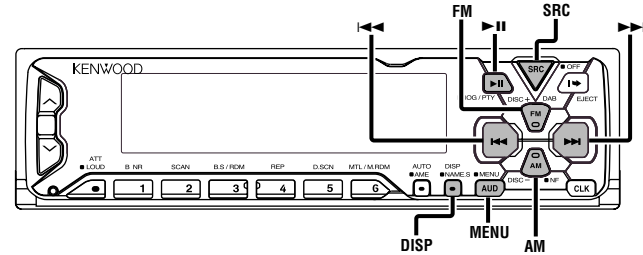

Text / Title Scroll

This function permits the text to be scrolled and the entire text to be displayed. The scrolling method differs depending on the setting of scrolling in the menu.

To scroll automatically:

Press the DISP button to display the disc title or the track title.
The display of the text will be scrolled repeatedly.

To scroll manually:

- 1 Press the DISP button to display the disc title or the track title.
- 2 Pressing the DISP button for at least one second results in one scrolling display of the titles.

NOTE

Please see the menu settings (page 33) about switching between manual scrolling and automatic scrolling.

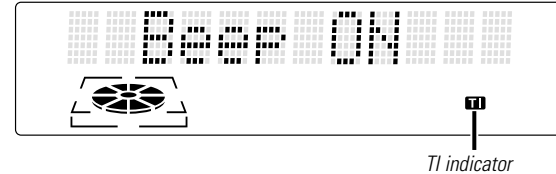

Menu settings

Menu System

You can set the defaults for additional functions in the menu mode.

Make a setting for each function, referring to the following operations.

1 Enter the menu mode

Press the MENU button for at least one second.

"MENU" is displayed when the menu mode is entered.

The function that you can adjust is indicated with the current settings displayed.

2 Selecting function to set

Press the FM button to search through the functions until you see the one you want to adjust in the display.

Press the AM button to search through the functions backward.

Example: If you want to switch the setting of the touch sensor tone function from on to off, first search through the functions until you see "Beep ON" in the display.

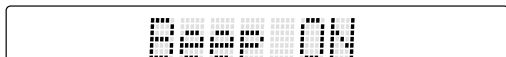

3 Changing setting for currently displayed function

Press either the ◀◀ or ▶▶ button.

The setting will change for each function.

Example: The setting of the touch sensor tone will switch from on to off, and "Beep OFF" is displayed.

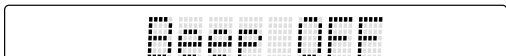

4 Ending the menu mode

Press the MENU button.

NOTE

- Make sure to end the menu mode when finished.
- If you fail to end the menu mode, several functions may not operate properly, including the Traffic Information function and the Alarm function. (KRC-X858 only).

Touch Sensor Tone

This function produces a beep sound that accompanies button operation. It can be switched on or off.

Display and setting:

"Beep ON" : Beep setting is on.

"Beep OFF" : Beep setting is off.

NOTE

The beep sound is not output from the preout jacks.

Manual Time Adjustment

Adjust the time manually.

NOTE

(KRC-X858 only)

This adjustment is available only when the automatic time adjustment is set to off. (page32)

Display and setting:

- 1 Select the display "CLK Adjust" during the selecting function in the menu system.
- 2 Press either the ◀◀ or ▶▶ button for at least two seconds to enter the Manual time adjustment mode.
The time display will blink.
- 3 • Adjusting the hours
Press the FM button to advance the hours, or press the AM button to make the hours go back.
• Adjusting the minutes
Press the ▶▶ button to advance the minutes, or press the ◀◀ button to make the minutes go back.
- 4 Press the MENU button to end the menu mode.

Calendar Adjustment

Adjust the date for the unit so that you can use the calendar function.

Display and setting:

- 1 Select the display "Date Adjust" during the selecting function in the menu system.
- 2 Press either the ◀◀ or ▶▶ button for at least two seconds to enter the Calendar adjustment mode.
The date display will blink.
- 3 **Selecting the item (day, month, or year) to adjust**
Press the ◀◀ or ▶▶ button.
The item blinking in the display can be adjusted.
- 4 **Adjusting the date**
Press the FM or AM button
The item of the date blinking in the display will change.
- 5 Press the MENU button to end the menu mode.

Calendar Mode

You can set the date formats of the calendar function.

Display and setting:

- 1 Select the display "Date Mode" during the selecting function in the menu system.
- 2 Press the ◀◀ and ▶▶ button to select the date format you want to show in the display.
The sample of the date format for today is displayed.

Menu settings

Memo Mode

You can input the text to be displayed and set the date when that text will appear in the display with the calendar function.

Display and setting:

- 1 Select the display "Memo Mode" during the selecting function in the menu mode.
- 2 Press either the ◀◀ or ▶▶ button for at least two seconds to enter the Memo mode.
The date display will blink.
- 3 **Selecting the set of the date and text to be displayed**
Press the FM and AM button.
If you want to input a new text, select the blank display.
- 4 **Entering the month or day setting mode**
Press the ◀◀ and ▶▶ button to enter the month or day setting mode.
The month display blinks when in month mode, the day display blinks when in day setting mode.
- 5 **Changing the month or day**
Press the FM and AM button.
- 6 **Entering the text input mode**
Press the ▶▶ button to enter the text input mode.
The cursor blinks in the position where character input can be made.
- 7 **Inputting / Changing the text**
 - Moving the cursor
Press the ◀◀ and ▶▶ button.
 - Changing the type of characters
Press the ▶|| button.
Each time the button is pressed, the type of characters switches as follows.

Alphabet (upper case): A ~ Z

Alphabet (lower case): a ~ z

Numerals and symbols: 0~9 @ " ' ` % & * + - = , . / \ < > []

Special characters: á à é ê ì í ó ù ù Ñ Ç \$ ß Ì Å ä è
ë ì í ó ù ù Ñ Ç \$ ß Ì Å ä è

- Selecting the character
Press the FM and AM button.

- 8 Press the MENU button to end the menu mode.

NOTE

- The text you selected automatically appears on the date you set when the unit's power is first turned on. (Calendar function)
The DISP button for at least one second scrolls the display once, regardless of the text scroll setting.
Pressing a button other than the DISP button will cause the text to disappear from the display.
- You can enter up to 32 characters for each text.
- The calendar function can be set up to 30 cases.
- To delete the date and text setting, set both the month and day of the date to "00" or set all of the text to blanks.

Function of the KRC-X858

Automatic Time Adjustment

With automatic time adjustment, you can set the clock time automatically according to time data sent from RDS stations (after receiving RDS signals for several minutes). You can also set the time manually if the automatic time adjustment function is turned off. The factory default is manual time adjustment.

Display and setting:

- "SYNC ON" : Automatic time adjustment
- "SYNC OFF" : Manual time adjustment

Adjusting Time Automatically:

Tune to a RDS station and receive the signal for several minutes.

The clock will adjust automatically to the local time.

NOTE

The clock will not adjust automatically if the RDS station tuned to is not transmitting time data. In such a case, try another RDS station.

Manual Open Button Setting

By pressing the button hidden behind the upper left part of the faceplate during forced closing, you can open the faceplate. Follow the directions below to preset the number of times that this button needs to be pressed in order to open the faceplate.

Display and setting:

"OPEN SW 1" – "OPEN SW 3"

NOTE

The initial setting value is "1" .

Function of the KRC-X858

Traffic Information Function

You can listen to traffic information. If you are listening to tapes or discs, they will continue playing until a traffic bulletin is broadcast.

Display and setting:

"TI ON" : The Traffic Information function is on.

When the function is on, the TI indicator is turned on.

When a traffic bulletin begins to be broadcast, "TRAFFIC" will be displayed.

If you are listening to a tape or disc when a traffic bulletin begins, they will automatically be turned off.

When the bulletin ends or poor reception is experienced, the tape or disc will begin playing again.

"TI OFF" : The Traffic Information function is off.

Switching to a Different Traffic Information Station:

Use the ◀◀ / ▶▶ buttons to make an auto seek of the TI stations in a certain band.

NOTE

- When you are listening to a tape or disc, you cannot change to another TI station.
- When you turn on the TI function, the motorized antenna will extend automatically.

Clean Reception System Circuit (CRSC)

Temporarily have reception switched from stereo to mono to reduce multi-path noise when listening to the FM station. The factory default for this function is ON.

Display and setting:

"CRSC ON" : The CRSC is on.

"CRSC OFF" : The CRSC is off.

NOTE

Strong electrical fields (such as from power lines) may cause unstable sound quality when CRSC is turned on. In such a situation, turn it off.

Text Scroll

This function permits the CD text, MD title, Radio text, and Calender function to be scrolled and the entire text to be displayed. Switching between manual scrolling and automatic scrolling is permitted. The factory default is automatic scrolling.

Display and setting:

"Scroll Auto" : Automatic scrolling

"Scroll Manu" : Manual scrolling

Menu settings

Security Code

When the battery is removed from the unit's power switch, you cannot turn on the unit again unless the preset security code is input. This function helps prevent theft.

NOTE

You must follow steps 1 to 9 to be able to use the Security Code function. Turning off the power during the procedure will deactivate the security code setting.

Once the security code function has been activated, "Security" disappears from the MENU system. Note that it will no longer be possible to cancel this function afterwards.

- 1 Press the SRC button repeatedly to select the standby mode. "ALL OFF" is displayed when the standby mode is selected.
- 2 Select the four digits to use in your security code.

NOTE

The four-digit security code is very important, as you will need it to turn the unit on again when the code security function is on. Choose the number carefully and do not forget it (write it down and keep it separately in a safe place).

- 3 Press the MENU button for at least one second. "MENU" is displayed and the menu mode is turned on.
- 4 Keep pressing the FM button until the "Security" appears in the display. Press the AM button to search in the other direction.
- 5 Press either the ◀◀ or ▶▶ button for at least two seconds. "ENTER" will appear in the display for one second, indicating the code setting mode has been entered. When "CODE" appears in the display, you can start inputting the code.
- 6 Press the preset button and enter the security code that you have selected in step 2.
Example: Use "3510" as the security code.

Step	Button to press	# Times pressed	Display
1	#1	4	"3"
2	#2	6	"5"
3	#3	2	"1"
4	#4	1	"0"

- 7 Press the DISP button for at least three seconds. The security code will be set. "RE-ENTER" will appear in the display for one second, asking you to enter the code once again for confirmation. When "CODE" appears in the display, you can start inputting the code.
- 8 Press the Preset button and input the security code again.
- 9 Press the DISP button again for at least three seconds. "APPROVED" will appear in the display, with the security code function turning on. From this point on, if the unit is disconnected from the battery, the security code must be entered the first time that the unit's power is turned on. "ENTER" and "CODE" will appear in the display, asking you to input the code.

NOTE

If you input an incorrect security code, the code setting mode will be canceled automatically. Follow the steps from 5 to 9 above again.

If you press the RESET button or remove the battery:

The first time you turn the unit on again, "CODE" will appear in the display, asking you to input the security code. Repeat steps 8 and 9 above, and input the security code. You can start operating the unit again when "APPROVED" appears in the display.
If you enter the incorrect code, the power will turn off. Enter the correct code to turn the unit on.

Selectable Illumination

You can switch the color of the button illumination between green and red.

Display and setting:

"Color Green" : The color of the illumination is green.

"Color Red" : The color of the illumination is red.

Contrast Adjustment

This adjustment permits easy viewing of the display.

Display and setting:

"Contrast 0" – "Contrast 10"

NOTE

The initial setting value is "5" .

Dimmer

You can dim the display.

NOTE

The dimmer function is not available for units if the dimmer wire is not connected.

Display and setting:

"Dimmer ON" : The dimmer setting is on.

"Dimmer OFF" : The dimmer setting is off.

Switching Graphic Display

You can turn the movement of graphic display on and off.
The initial setting is ON.

Display and setting:

"Graphic ON" : The graphic display works.

"Graphic OFF" : The graphic display does not work.

Black Mask

This function allows you to turn off the lower part of the display if there is too much information in the display.

Display and setting:

"BLK MASK ON" : The display will turn on by using only the upper part of the display and the IN indicator

"BLK MASK OFF" : The display will turn on by using the whole part of the display.

Time setting for removing the faceplate

You can set the interval during which the open control panel cannot reverse to be hidden. During the period you have set, the faceplate can be removed from the faceplate bracket.

Display and setting:

"OFF WAIT" : 0s / 3s / 5s / 10s / 15s / 20s / 25s (s=sec.)

NOTE

If you do not slide the faceplate lock switch during the period which you have set, the unit's power turns off after the control panel is automatically hidden.

Function of the KRC-X858

Switching preout

Switch the preout between the rear and non-fading. When you switch to non-fading, you can adjust the volume separately. The factory default is rear preout.

Display and setting:

"SWPRE Rear" : Rear preout

"SWPRE N-Fad" : Non-fading preout

NOTE

You cannot use the high-pass filter with non-fading preout.

Menu settings

Function of the KRC-X858

Dual Zone System

The following operation allows separate sound sources to control the output of the front and rear speakers. The Dual zone system can only be switched on or off when the source is set to the AUX mode.

Display and setting:

"Zone 2 ON" : The dual zone system function is on.

"Zone 2 OFF" : The dual zone system function is off.

NOTE

- You must purchase the optional KCA-S210A/CA-C1AX/KDC-CPS82/KDC-CX82/KDC-CPS85/KDC-CX85 device before you can use this function.
- You can choose to send the AUX input through the rear channel, and the unit's tuner or tape source through the front channel.
- The Bass, Treble and Loudness adjustments do not affect the rear channel.
- When the Dual zone system is turned on, the External disc control features cannot be used.
- When you set the Dual zone system to on while the non-fading preout is switched on, the sound of the non-fading preout does not be outputted.

KEX/ec4/dB (Sound Coordinate system)

When this system is set to on, the sound coordinate factors (Bass Frequency, Bass quality, Bass extension, and Treble frequency) appear during the audio control mode.

Display and setting:

"Kex/ec4/dB set ON" : The sound coordinate factors appear and can be adjusted.

"Kex/ec4/dB set OFF" : The sound coordinate factors are not appeared.

External Amp Control

Adjust the bass boost level of the external amplifier using the main unit.

Display and setting:

"AMP BASS FLT" : Bass boost level is flat.

"AMP BASS +6" : Bass boost level is low (+6dB).

"AMP BASS +12" : Bass boost level is high (+12dB).

NOTE

As of December 1999, the power amplifiers controllable by the main unit are as follows:

KAC-X501F/PS501F/X401M/PS401M/X301T/PS301T/X201T/PS201T

Basic Operations of remote

KRC-X858

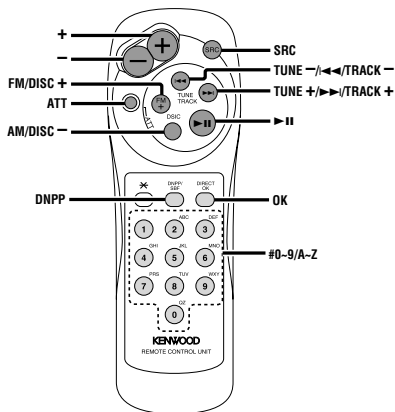

KRC-708

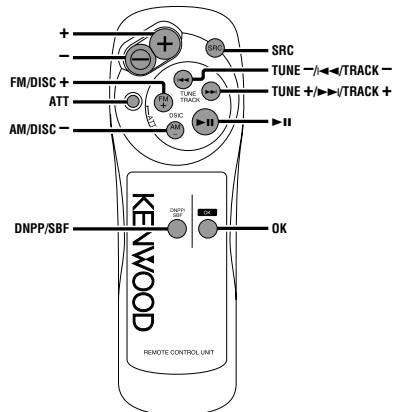

▲CAUTION

Do not set the remote on hot places such as above the dashboard.

Loading and Replacing the Batteries:

Use two "AAA"-size batteries.

Slide the cover while pressing downwards to remove it as illustrated.

Insert the batteries with the + and - poles aligned properly, following the illustration inside the case.

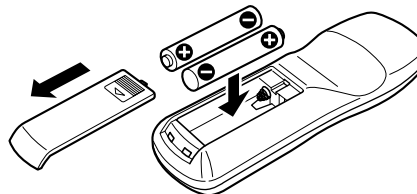

▲WARNING

Store unused batteries out of the reach of children. Contact a doctor immediately if the battery is accidentally swallowed.

NOTE

- The provided batteries are intended for use in operation checking, and their service life may be short.
- When the remote controllable distance becomes short, replace both of the batteries with new ones.

NOTE

A portion of the operations may not be possible, depending on the unit that is connected.

Basic Operations of remote

Basic operations

- **VOLUME buttons**
Press the **+** button to turn the volume up.
Press the **-** button to turn the volume down.
- **SRC button**
Each time you press the SRC button, the mode switches as follows:

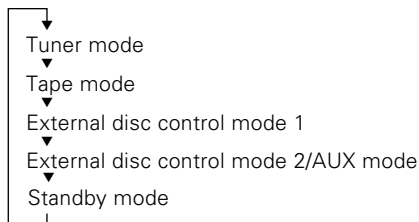

NOTE

- The mode switches to the next mode from any mode which cannot be used.
- The external disc control mode will differ depending on the unit that is connected.
- The AUX mode is available only when the changer / AUX switching adapter (KCA-S210A or CA-C1AX) or CD changer (KDC-CPS85, KDC-CX85, KDC-CPS82 or KDC-CX82) is connected to this unit.
During the AUX mode, "AUX" / AUX-name will show in the display.
When the CA-C1AX is being used, the AUX Mode will replace the External Disc Control Mode.
- **ATT button**
Turns down the volume quickly. To return the volume to its original level, press the button again. Turning the volume up, or turning it all the way down deactivates the attenuator function.

Tuner features

- **◀◀/▶▶ (TUNE) buttons**
Press the **◀◀** button to make decreasing seeks (using the preset tuning mode).
Press the **▶▶** button to make increasing seeks (using the preset tuning mode).
Use to move the cursor left or right during station name input.
- **AM/FM button**
Press the AM button to select the AM band.
Press the FM button to select and switch between FM1, FM2, and FM3 bands.
During station name input, selects digits and symbols.
- **OK button**
During station name input, stores the already input data in memory and ends the input mode.
During Station name preset play mode, selects station.
- **DNPP button**
Enters and cancels the Station Name Preset Play mode.
- **▶|| button**
Enters and cancels the Program Type Selection (PTY) mode.
Selects the type of characters at the time of entering the station name.
- **Number/ letter entry buttons (KRC-X858 only)**
Press buttons #1-6 to recall preset stations.
Use to enter letters (alphabetical) during station name preset.

Cassette player features

- **◀◀/▶▶ buttons**
Press the **◀◀** button to start play again at the beginning of the current track.
Press the **▶▶** button to start play at the beginning of the next track.
Press either the **◀◀** or **▶▶** button to skip backward or forward to other tracks after entering the number of tracks used in DPSS.





- **AM button**
Rewinds the tape.
- **FM button**
Fast forwards the tape.
- **▶|| button**
Plays the reverse side of the tape. When pressed during fast forward and rewind, this button stops the tape and starts playing it.
- **Number/ letter entry buttons (KRC-X858 only)**
Use to enter the number of tracks you want to skip used in DPSS.(#1-9)

External disc control features

- **◀◀/▶▶ buttons**
Press the ◀◀ button to search through the tracks backward.
Press the ▶▶ button to search through the tracks forward.
Use to move the cursor while entering disc name.
- **DISC buttons**
Press the DISC- button to search through the discs backward.
Press the DISC+ button to search through the discs forward.
Select numbers and symbols while entering disc name.
- **▶|| button**
When a disc is playing, this button pauses the play.
Press the same button again to start play again.
Selects the type of characters at the time of entering the disc name.
- **OK button**
During disc name input, stores the already input data in memory and ends the input mode.
Selects disc during the disc name preset play mode.
- **DNPP button**
Enters and cancels the Disc Name Preset Play mode.
- **Number/ letter entry buttons (KRC-X858 only)**
Used to specify the track (disc) number used in direct track (disc) searches.
Use to enter letters during disc name preset.

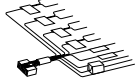
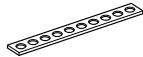
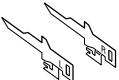
Accessories



External view

	Number of items
①	1
②	1
③	1
④	1
⑤	2
⑥	2

▲CAUTION

Do not use any accessories other than those provided with your unit. If you use other accessories, you may damage the unit.

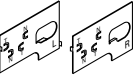
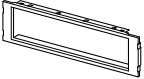
External view

	Number of items
⑦	1
⑧	1
⑨	1
⑩	1

Installation Procedure

1. To prevent a short circuit, remove the key from the ignition and disconnect the ⊖ battery.
2. Make the proper input and output wire connections for each unit.
3. Connect the speaker wires of the wiring harness.
4. Connect the wiring harness wires in the following order: ground, battery, ignition.
5. Connect the wiring harness connector to the unit.
6. Install the unit in your car.
7. Reconnect the ⊖ battery.

▲CAUTION

- If your car's ignition does not have an ACC position, connect the ignition wires to a power source that can be turned on and off with the ignition key. If you connect the ignition wire to a power source with a constant voltage supply, as with battery wires, the battery may die.
- If the console has a lid, make sure to install the unit so that the faceplate will not hit the lid when closing and opening.
- If the fuse blows, first make sure the wires aren't touching to cause a short circuit, then replace the old fuse with one with the same rating.
- Do not let unconnected wires or terminals touch metal on the car or anything else conducting electricity. To prevent a short circuit, do not remove the caps on the ends of the unconnected wires or the terminals.
- Connect the speaker wires correctly to the terminals to which they correspond. The unit may be damaged or fail to work if you share the ⊖ wires or ground them to any metal part in the car.
- After the unit is installed, check whether the brake lamps, blinkers, wipers, etc. on the car are working properly.
- Insulate unconnected wires with vinyl tape or other similar material.
- Some disc changers need conversion cords for connection. See the section on "Safety Precautions" for details.

Connecting Wires to Terminals

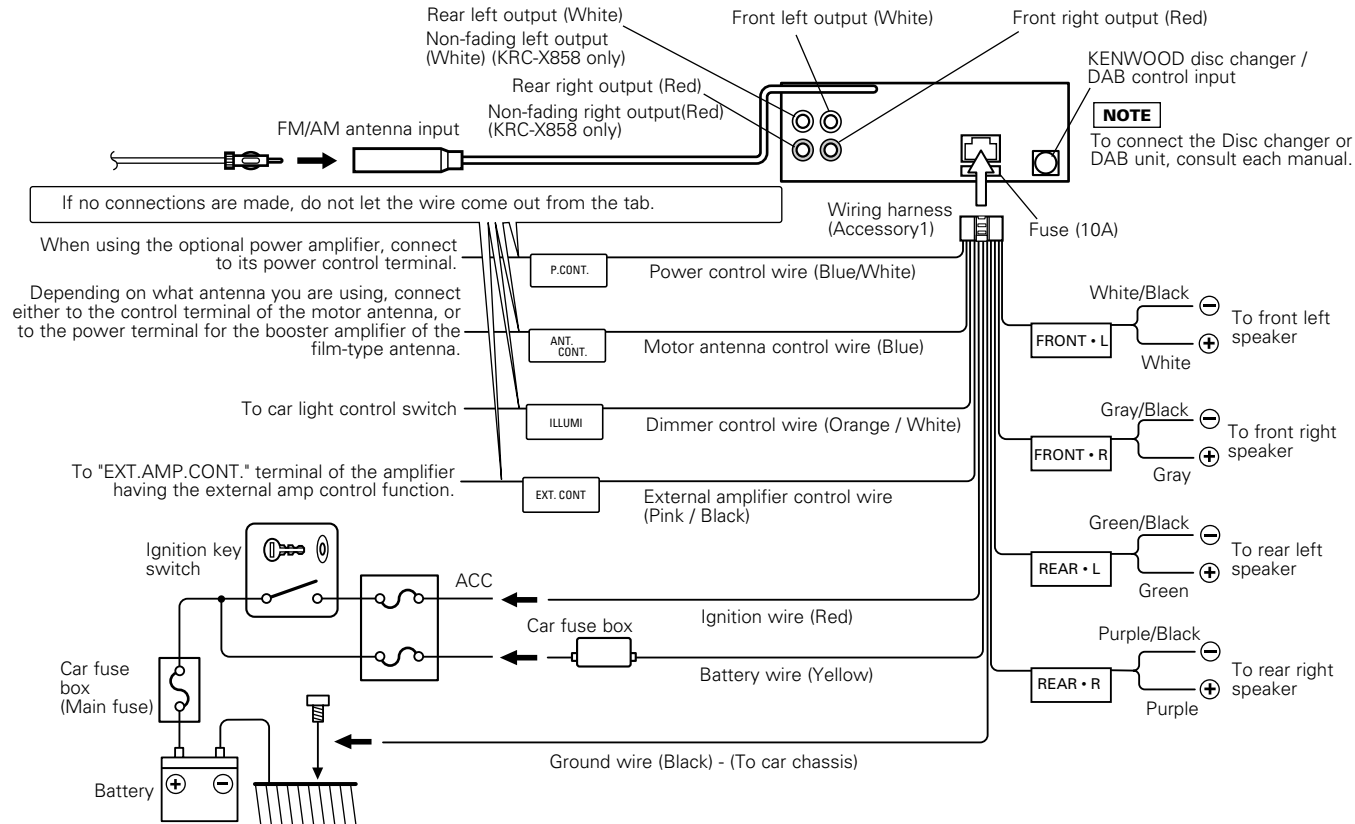

⚠ WARNING

If you connect the ignition wire (red) and the battery wire (yellow) to the car chassis (ground), you may cause a short circuit, that in turn may start a fire. Always connect those wires to the power source running through the fuse box.

⚠ CAUTION

When only two speakers are being connected to the system, connect the connectors either to both the front output terminals or to both the rear output terminals (do not mix front and rear). For example, if you connect the + connector of the left speaker to a front output terminal, do not connect the - connector to a rear output terminal.

Installation (non-Japanese cars)

■ Installation (non-Japanese cars)

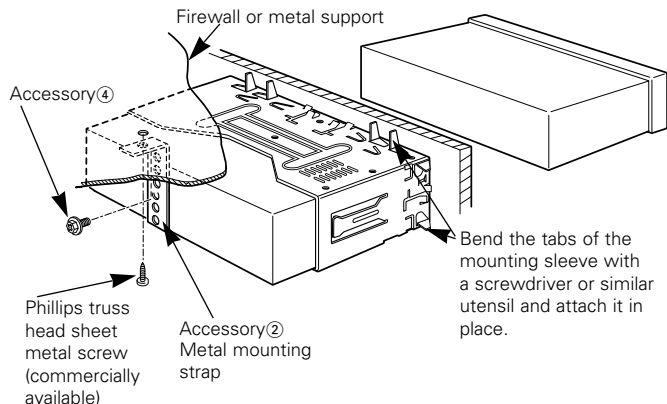

NOTE

Make sure that the unit is installed securely in place. If the unit is unstable, it may malfunction (for example, the sound may skip).

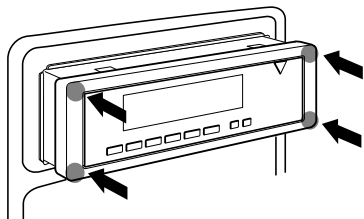

CAUTION

To attach this unit, make sure the front of the control panel faces you and fit it into the mounting sleeve by pressing the four corners of the hard rubber frame at the same time.

Do not apply strong pressure to other sections than the corners; otherwise troubles such as the impossibility of opening or closing the panel may result.

Locking the faceplate to the unit

■ Locking the faceplate to the unit

If you want to lock the faceplate to the unit so that it does not fall off, follow the directions below.

- 1 Refer to the function "Removing the faceplate" (page 12) and remove the faceplate.
- 2 Insert the provided screw into the hole at the center of the bottom side of the faceplate which you have removed from the unit.

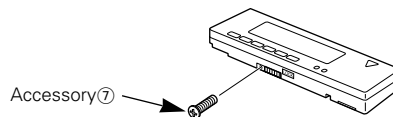

- 3 Refer to the section "Removing the faceplate (page 12)" and then reattaching the faceplate.

CAUTION

Never insert the taptite screws ($\phi 2 \times 6$ mm) in any other screw holes than the one specified. If you insert it in another hole, it will contract and may cause damage to the mechanical parts inside the unit.

Removing the Unit

■ Removing the hard rubber frame

Insert the removal tool into the indentations in the hard rubber frame, and pull it gently until the lock is released.

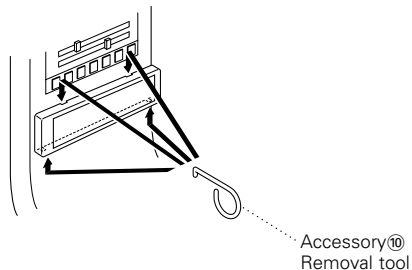

■ Removing the Unit

- 1 Make the faceplate control panel appear.
- 2 Refer to the section “Removing the hard rubber frame” and then remove the hard rubber frame.
- 3 Remove the hex head machine screw with washer (M4×8) on the back panel.
- 4 Insert the removal tool deeply, as illustrated, with the L on the left and the R on the right.

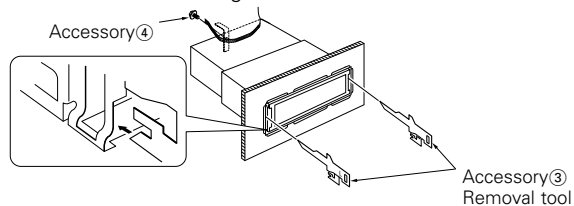

NOTE

If the unit is removed while the faceplate is closed, use the removal tool with the left and right reversed, as illustrated.

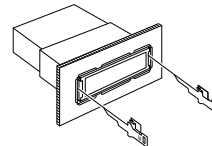

- 5 Push upward the both tools, as shown, and pull the unit toward you until it is halfway out. The unit may drop if you pull it out completely.

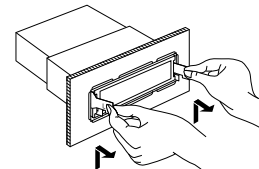

- 6 Pull the unit all the way out with your hands, being careful not to drop it.

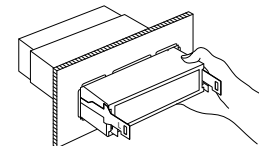

Installation (Japanese-cars)

■ Installing Radio Bracket in Japanese-made Cars (J-Cars)

On the factory-installed radio bracket, flatten all the tabs or holes that are not flush (except those used for screws), using a hammer or similar utensil.

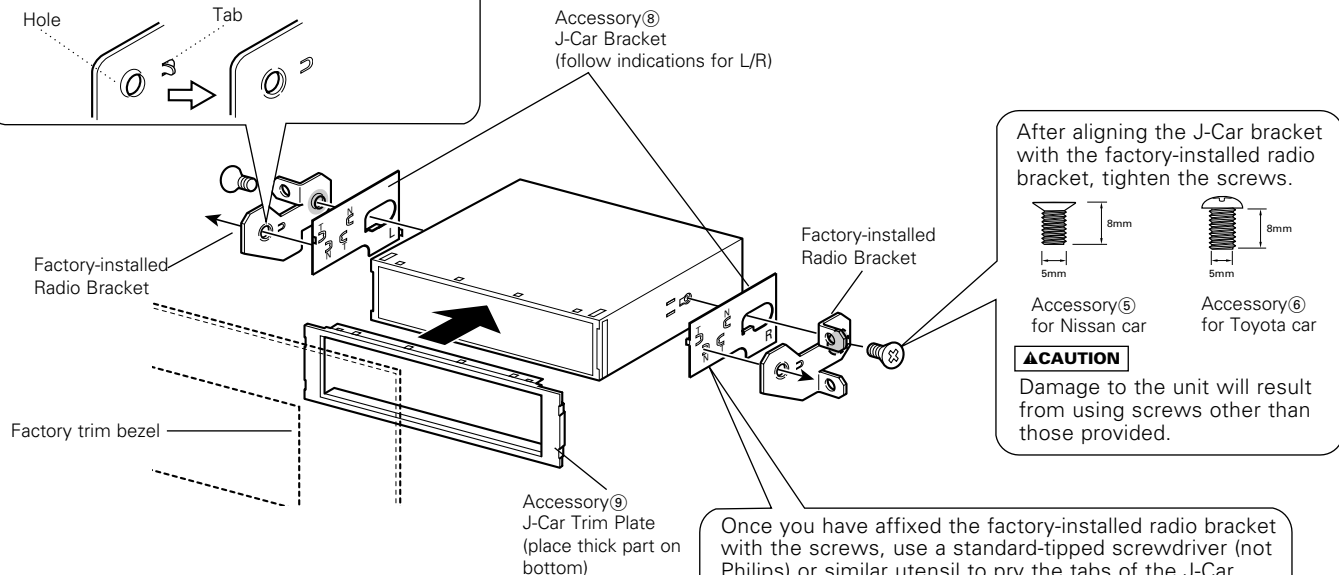
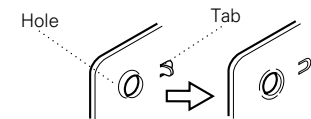

After aligning the J-Car bracket with the factory-installed radio bracket, tighten the screws.

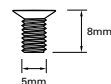

Accessory^⑤
for Nissan car

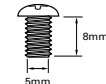

Accessory^⑥
for Toyota car

▲CAUTION

Damage to the unit will result from using screws other than those provided.

Once you have affixed the factory-installed radio bracket with the screws, use a standard-tipped screwdriver (not Philips) or similar utensil to pry the tabs of the J-Car bracket to make them fit into the holes in the factory-installed radio bracket (depending on the car make).

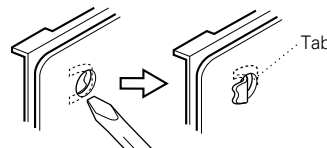

N ... Nissan car
T ... Toyota car

Troubleshooting Guide

What might seem to be a malfunction in your unit may just be the result of slight misoperation or miswiring. Before calling service, first check the following table for possible problems.

PROBLEM	POSSIBLE CAUSE	SOLUTION
The power does not turn on.	The fuse has blown.	After checking for short circuits in the wires, replace the fuse with one with the same rating.
No sound can be heard, or the volume is low.	Attenuator is turned on.	Turn off Attenuator.
	The fader or balance settings are set all the way to one side.	Reset the fader or balance settings.
	The input/output wires or wiring harness are connected incorrectly.	Reconnect the input/output wires or the wiring harness correctly. See the section on "Connecting Wires to Terminals".
	The cassette tape is bad.	Try playing another cassette tape. If works fine, the first tape was bad.
	The values of "V OFFSET" are low.	Increase the values of "V OFFSET". (see p. 9)
The tape does not go in. / No sound can be heard even though the tape display is made.	The car ignition was turned off during tape eject; or the tape was pulled out during loading, switching the mode to tape mode even though no tape is in.	Press the Eject button.
Nothing happens when the buttons are pressed.	The computer chip in the unit is not functioning normally.	Press the reset button on the unit (see p. 4).
The sound quality is poor or distorted.	The tape head is dirty.	Clean the tape head, referring to the section on "Cleaning the tape head" (see p. 4).
	One of the speaker wires is being pinched by a screw in the car.	Check the speaker wiring.
	The speakers are not wired correctly.	Reconnect the speaker wires so that each output terminal is connected to a different speaker.
Radio reception is poor.	The car antenna is not extended.	Pull the antenna out all the way.
	The antenna control wire is not connected.	Connect the wire correctly, referring to the section on "Connecting Wires to Terminals".
The memory is erased when the ignition is turned off.	The battery wire has not been connected to the proper terminal.	Connect the wire correctly, referring to the section on "Connecting Wires to Terminals".
	The ignition and battery wire are incorrectly connected.	Connect the wire correctly, referring to the section on "Connecting Wires to Terminals".

CD/External disc control mode

PROBLEM	POSSIBLE CAUSE	SOLUTION
The disc control mode cannot be selected.	No wire has been connected to the disc changer input terminal on the unit.	Connect the wire to the disc changer input terminal on the unit.
The specified disc does not play, but another one plays instead.	The specified CD is quite dirty.	Clean the CD.
	The CD is upside-down.	Load the CD with the labeled side up.
	The disc is loaded in a different slot from that specified.	Eject the disc magazine and check the number for the specified disc.
	The disc is severely scratched.	Try another disc instead.
The sound skips.	Something is touching the disc changer.	Remove whatever is touching it.
	The CD is scratched or dirty.	If skipping happens at the same place when the car is stopped, something with the CD is wrong. Clean the CD.
The display shows that the changer is being played, but no sound can be heard.	The computer chip in the unit is not functioning normally.	Press the reset button on the unit (see p. 4).
The specified track will not play.	Random play or magazine random play has been selected.	Turn off random play or magazine random play.
Track repeat, disc repeat, track scan, disc scan, random play, and magazine random play start by themselves.	The setting is not cancelled.	The settings for these functions remain on until the setting to off or the disc ejected, even if the power is turned off or the source changed.

If the following situations, consult your nearest service center:

- Even though the disc changer is connected, the Disc Changer Mode is not on, with "AUX" showing in the display during the Changer Mode.
- Even though no device (KCA-S210A, CA-C1AX, KDC-CPS85, KDC-CX85, KDC-CPS82 or KDC-CX82) is connected, the AUX Mode is entered when switching modes.

Troubleshooting Guide

The following messages are displayed when certain problems are occurring in your system. Take the recommended actions.

EJECT	No disc magazine has been loaded in the changer. The disc magazine is not completely loaded. ⇒ Load the disc magazine properly. No CD in the unit. ⇒ Insert the CD.
NO DISC	No disc has been loaded in the disc magazine. ⇒ Load a disc into the disc magazine.
E-04	No disc has been loaded in the disc magazine. ⇒ Load a disc into the disc magazine. The CD is quite dirty. The CD is upside-down. The CD is scratched a lot. ⇒ Clean the CD and load it correctly.
BLANK	Nothing has been recorded on the MD.
NO TRACK	No tracks are recorded on the MD, although it has a title.
NO PANEL	The faceplate of the slave unit being connected to this unit has been removed. ⇒ Replace it.
E-77	The unit is malfunctioning for some reason. ⇒ Press the reset button on the unit. If the "E- 77" code does not disappear, consult your nearest service center.
E-99	Something is wrong with the disc magazine. Or the unit is malfunctioning for some reason. ⇒ Check the disc magazine. And then press the reset button on the unit. If the "E- 99" code does not disappear, consult your nearest service center.
HOLD	The protective circuit in the unit activates when the temperature inside the automatic disc changer exceeds 60°C (140°F), stopping all operation. ⇒ Cool down the unit by opening the windows or turning on the air conditioner. As the temperature falls below 60°C (140°F), the disc will start playing again.
IN	If this indicator continues blinking, it is possible that the tape has become jammed or tangled. ⇒ Contact the Kenwood dealer if the cassette tape cannot be ejected.

Specifications

Specifications subject to change without notice.

FM tuner section

Frequency Range (200 kHz Space).....	87.9 - 107.9 MHz
Usable Sensitivity (S/N: 30dB).....	9.3 dBf (0.8 μ V/75 Ω)
Quieting Sensitivity (S/N: 50dB)	15.2 dBf (1.6 μ V/75 Ω)
Frequency Response (\pm 3.0dB).....	30 Hz-15 kHz
Signal to Noise ratio	70 dB (MONO)
Selectivity.....	\geq 80 dB (\pm 400 kHz)
Stereo Separation.....	40 dB (1 kHz)

AM tuner section

Frequency Range (10 kHz space).....	530 kHz - 1700 kHz
Usable Sensitivity (S/N: 20 dB).....	28 dB μ (25 μ V)

Cassette player section

Tape Speed	4.76 cm/sec.
Wow & Flutter	0.08 % (WRMS)
Frequency response (\pm 3 dB).....	30 Hz - 18 kHz (70 μ s)
Separation	43 dB (1 kHz)
Signal to Noise ratio	
Dolby NR OFF.....	57 dB
Dolby B NR ON.....	65 dB

Audio section

Preout Level(mV)/Load	
(KRC-X858; during CD changer mode).....	4500 mV/10 k Ω
(KRC-708)	1800 mV/10 k Ω
Preout Impedance	
(KRC-X858)	80 Ω
(KRC-708)	\leq 600 Ω
Maximum output power	45 W x 4
Full Bandwidth Power (at less than 1% THD)	22 W x 4
Tone action	
Bass	100 Hz \pm 10 dB
Treble	10 kHz \pm 10 dB

General

Operating voltage (11 - 16V allowable)	14.4 V
Current Consumption	10 A
Installation Size (W x H x D)	182 x 53 x 161 mm
	7-3/16 x 2-1/16 x 6-5/16 in.
Weight	3.7 lbs (1.7 kg)

KENWOOD

Content

U.S.A.	2
Australia	3
Canada	4
Military	6
Belgique et Grand-duché de Luxembourg	8
Danmark	9
Deutschland	9
Nederland	10
Portugal	10
U.K. & Ireland	11
Österreich	11
Ellás	12
España	12
France	13
Italia	13
Suomi	14
Andorra	14
Iceland	14
Malta	14
Norge	15
Schweiz	15
Svizzera	15
Suisse	15
Sverige	15

Dear Customer,

Thank you for purchasing the Product. As mentioned on this page of this booklet, our Warranty is only valid in the countries listed. If your country is not listed please contact your retailer for information on warranty procedure or write to:

KENWOOD Customer Information Center
3-17-9 Aobadaí
Meguro-ku Tokyo 153-0042 JAPAN
Kenwood Corporation
Customer Information Center

Page	
	2
	3
	4
	6
	8
	9
	9
	10
	10
	11
	11
	12
	12
	13
	13
	14
	14
	14
	14
	14
	14
	15
	15
	15
	15
	15
	15

KENWOOD

Warranty Card

Geräte-Typ und Seriennummer
Identification du produit
Produkt navn og serie nummer
Modelo y Número de serie
Malli ja sarjanumero
Μοντέλο και αριθμός σειράς
Modello e numero di matricola
Modell og serienummer
Modelo e numero de serie
Apparat typ & serienummer
Identificatie van het produkt
Módel heiti og raðnumber
Il-Modell u s-serial number
Model name & serial number

Stempel und Unterschrift des Händlers
Revendeur & cachet
Forhandler
Distribuidor y sello
Jälleenmyyjä & leima
Συμπράξια εταιρίας
Timbro del rivenditore
Forhandlerens navn og stempel
Agente e carimbo
Återförsäljare & stämpel
Dealer & stempel
Undirritun og stimpill sóluáðila
Timbru tal-bejjeigh
Dealer & stamp

Kaufdatum
Date d'achat
Købsdato
Fecha de compra
Ostopäivä
Ημερομηνία αγοράς
Data di acquisto
Kjøpt dato
Data de compra
Inköpsdatum
Aankoopdatum
Söludagur
Íd-data ta' meta nxtara
Purchase date

Name und Anschrift des Käufers
Nom & adresse du client
Købers navn og adresse
Nombre y dirección del cliente
Asiakkaan nimi & osoite
Όνομα και διεύθυνση αγοραστή
Nome e indirizzo del cliente
Kundens navn og adresse
Nome e morada do comprador
Kundens namn & adress
Naam & adres van de klant
Nafn og heimilisfang kaupanda
L-ísem u l-índirizz tax-xerrej
Name & address of customer

The tables of content are a back cover

This warranty will be honored only in the U.S.A.

KENWOOD LIMITED WARRANTY FOR CAR STEREO COMPONENTS

HOW LONG IS THE WARRANTY

Kenwood U.S.A. Corporation ("Kenwood") warrants this product for a period of one (1) year from the date of original purchase.

WHAT IS COVERED AND WHAT IS NOT COVERED

Except as specified below, this warranty covers all defects in material and workmanship in Kenwood car stereo components. The following are not covered by the warranty:

1. Any product which is not distributed in the U.S.A. by Kenwood or which is not purchased in the U.S.A. from an authorized Kenwood car stereo dealer or an automobile dealer, unless the product is purchased through the U.S.A. Military Exchange Service.
2. Any product on which the serial number has been defaced, modified or removed.
3. Damage, deterioration or malfunction resulting from:
 - a. Any shipment of the product (claims must be presented to the carrier).
 - b. Installation or removal of the product.
 - c. Accident, acts of nature, misuse, abuse, neglect, unauthorized product modification or failure to follow instructions supplied with the product.
 - d. Repair or attempted repair by anyone not authorized by Kenwood.
 - e. Any other cause which does not relate to a product defect.

WHO IS PROTECTED

This warranty is enforceable only by the original purchaser.

WHAT WE WILL PAY FOR

We will pay for all labor and material expenses for covered items. Payment of shipping charges is discussed in the next section of this warranty.

HOW TO OBTAIN WARRANTY SERVICE

If your KENWOOD product ever needs service:

1. Take or ship it to any KENWOOD Authorized Service Center in the U.S.A. along with a complete description of the problem. (if you are uncertain as to whether a Service Center is authorized, please call 1-800-KENWOOD for the nearest Service Center. 1-800-536-9663).
2. Although you must pay any shipping charges if it is necessary to ship the product for warranty service, we will pay the return shipping charges if the repairs are covered by the warranty within the United States.
3. Whenever your units are taken or sent for warranty service, you must include a copy of the original dated sales receipt as proof of warranty coverage.

LIMITATION OF IMPLIED WARRANTIES

ALL IMPLIED WARRANTIES, INCLUDING WARRANTIES OF MERCHANTABILITY AND FITNESS FOR A PARTICULAR PURPOSE, ARE LIMITED IN DURATION TO THE LENGTH OF THIS WARRANTY.

EXCLUSION OF DAMAGES

KENWOOD'S LIABILITY FOR ANY DEFECTIVE PRODUCT IS LIMITED TO THE REPAIR OR REPLACEMENT OF THE PRODUCT AT OUR OPTION. KENWOOD SHALL NOT BE LIABLE FOR:

1. INSTALLATION OR REMOVAL CHARGES, DAMAGE TO OTHER PROPERTY CAUSED BY ANY DEFECTS IN KENWOOD CAR STEREO COMPONENTS, DAMAGES BASED UPON INCONVENIENCE, LOSS OF USE OF THE PRODUCT; OR
2. ANY OTHER DAMAGES, WHETHER INCIDENTAL, CONSEQUENTIAL OR OTHERWISE.

SOME STATES DO NOT ALLOW LIMITATIONS ON HOW LONG AN IMPLIED WARRANTY LASTS AND/OR DO NOT ALLOW THE EXCLUSION OR LIMITATION OF INCIDENTAL OR CONSEQUENTIAL DAMAGES, SO THE ABOVE LIMITATIONS AND EXCLUSIONS MAY NOT APPLY TO YOU.

This warranty gives you specific legal rights, and you may also have other rights which vary from state to state.

If a problem develops during or after the Limited Warranty Period, or if you have any questions regarding the operation of the product, you should contact your KENWOOD Authorized Dealer or Authorized Service Center. If the problem or your question is not handled to your satisfaction, please contact our Customer Relations Department at the address listed below:

KENWOOD SERVICE CORPORATION
P.O. Box 22745, 2201 East Dominguez Street, Long Beach CA 90801-5745
Tel: (310) 639-5300

▲CAUTION

To attach this unit, fit it into the mounting sleeve by pressing the four corners of the hard rubber frame.
Do not apply strong pressure to other sections than the corners; otherwise troubles such as the impossibility of opening or closing the panel may result.

▲ATTENTION

Pour fixer cet appareil, engagez-le dans le manchon de montage en appuyant aux quatre coins du cadre en caoutchouc dur.
Veillez à ne pas appliquer une forte pression en dehors des coins; dans le cas contraire, il peut être impossible d'ouvrir ou de fermer le panneau.

▲ACHTUNG

Um dieses Gerät zu montieren, ist es in das Einbaugehäuse einzupassen, indem die vier Ecken des Hartgummiraumens nach unten gedrückt werden.
Darauf achten, daß außer an den vier Ecken auf keinen anderen Bereich Druck ausgeübt wird; wenn dies nicht beachtet wird, kann sich das Gehäuse verziehen und ein Öffnen bzw. Schließen der Frontklappe unmöglich werden.

▲LET OP

Voor het bevestigen van dit toestel moet u het in de bevestigingshuls steken door tegen de vier hoeken van het harde rubberframe te drukken.
Voer geen overmatige druk op andere delen dan de hoeken uit. U zult anders namelijk diverse problemen krijgen met bijvoorbeeld het openen en sluiten van het paneel.

▲ATTENZIONE

Per installare quest'unità, inserirla nella flangia di montaggio premendo sui quattro angoli della cornice di gomma dura. Non applicare una forte pressione alle altre sezioni della cornice, altrimenti si potrebbero avere problemi, come ad esempio la difficoltà di aprire e chiudere il pannello.

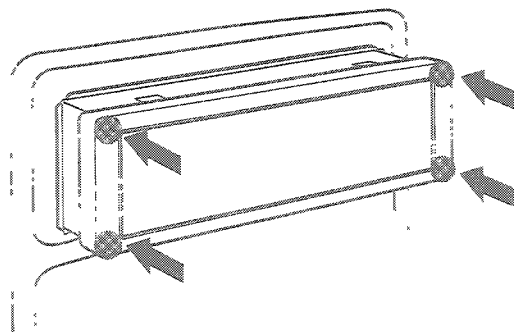

▲PRECAUTION

Para fijar esta unidad, encájela en el manguito de montaje presionando las cuatro esquinas del marco de goma dura.
No aplique mucha presión a otras secciones que no sean las esquinas, ya que podrían producirse problemas, como imposibilidad de apertura o cierre del panel.

▲CUIDADO

Para fixar este aparelho, encaixe-o na gaveta para montagem com o premer dos quatro cantos da armação de borracha dura.
Não aplique muita pressão a outras partes com exceção dos cantos pois, caso contrário, isto pode resultar em problemas como impedir a abertura ou fechamento do painel.

▲注意

通過按著硬橡膠框的四角，把它裝入安裝套盒。
注意按其表面的力量不能大於四角，
否則可能導致難以開啟或關閉控制板等麻煩。

▲CAUTION

If the panel automatically opens/closes every 30 minutes when power is turned on after the set installation, normal setting is not done

If it is used in such a state, the power is not turned off even when ACC is set to OFF and then no normal operation occurs, therefore, please contact your store

▲ATTENTION

Si le panneau ouvre/ferme automatiquement tous les 30 minutes alors que le contact est établi après l'installation des appareils, la fixation n'est pas correcte. En l'état, le contact reste établi même si ACC est éteint (OFF) et, par conséquent, le dispositif ne fonctionne pas normalement. En tel cas, contactez votre magasin, s v p.

▲PRECAUCIÓN

Si el panel se abre/cierra automáticamente cada 30 minutos cuando se conecta la alimentación después de la instalación del aparato, no puede realizarse la fijación normal

Si se usa en tal situación, la alimentación no se desconectará aun cuando el ACC se ponga en OFF, y ocurre un funcionamiento anormal. Por lo tanto, consulte al establecimiento donde adquirió el producto

▲注意

機械安裝、接通電源後，如操作面板每30分鐘自動開閉時，即表明未作正規的設定。

在這種情況下使用時，即使ACC置於OFF狀態，機械電源也不會關閉。這樣不能正常運轉，請向購買的店鋪問詢。

Please send other correspondence to
Kenwood USA Customer Service
PO Box 22745
Long Beach, CA 90801-5745



NO POSTAGE
NECESSARY
IF MAILED
IN THE
UNITED STATES

87Q01-01

BUSINESS REPLY MAIL

FIRST-CLASS MAIL PERMIT NO 8439 LONG BEACH, CA

POSTAGE TO BE PAID BY ADDRESSEE

KENWOOD

PO BOX 173272

DENVER CO 80217-9165

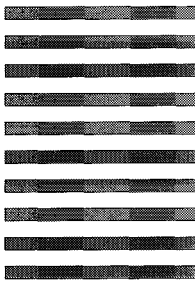

The Kenwood **SmartCard** • Register your product by mail, phone, or the web

Free CD sampler

Loaded with great new music
and mailed to you free when
you register on the web at
www.kenwoodusa.com.
(U.S. residents only.)

A chance to win \$50,000

You're entered to win when
you register by phone toll-free
at **1-888-592-7768** or when
you mail in this registration
card.

KENWOOD
e x c e l o n

CAR AUDIO

