

Clarion®

Owner's manual

XMA2

AM/FM CASSETTE PLAYER

■ Contents

1. PRECAUTIONS	2
2. FEATURES	2
3. CONTROLS	3
4. BUTTON TERMINOLOGY	3
5. CASSETTE PRECAUTIONS AND CARE	3
6. OPERATION	4
7. WIRED REMOTE CONTROL UNIT OPERATIONS	6
8. TROUBLESHOOTING	7
9. SPECIFICATIONS	7
Simple Guide	9

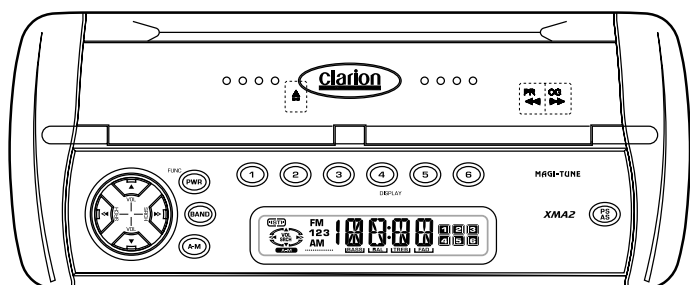

1. PRECAUTIONS

This equipment has been tested and found to comply with Part 15 of the FCC Rules. These limits are designed to provide reasonable protection against harmful interference in a residential installation. This equipment generates, uses, and can radiate radio frequency energy and, if not installed and used in accordance with the instructions, may cause harmful interference to radio communications. However, there is no guarantee that interference will not occur in a particular installation. If this equipment does cause harmful interference to radio or television reception, which can be determined by turning the equipment off and on, the user is encouraged to consult the dealer or an experienced radio/TV technician for help.

⚠ CAUTION

USE OF CONTROLS, ADJUSTMENTS, OR PERFORMANCE OF PROCEDURES OTHER THAN THOSE SPECIFIED HEREIN, MAY RESULT IN HAZARDOUS RADIATION EXPOSURE. THE CASSETTE PLAYER SHOULD NOT BE ADJUSTED OR REPAIRED BY ANYONE EXCEPT PROPERLY QUALIFIED SERVICE PERSONNEL.

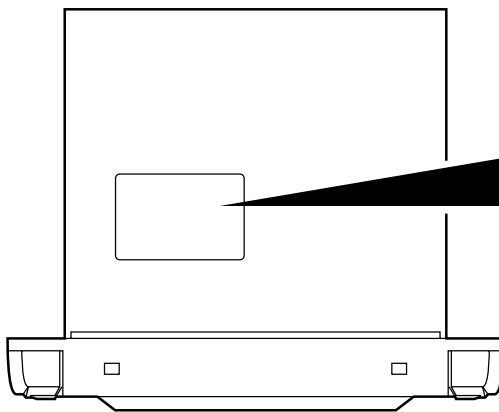

Bottom view of source unit

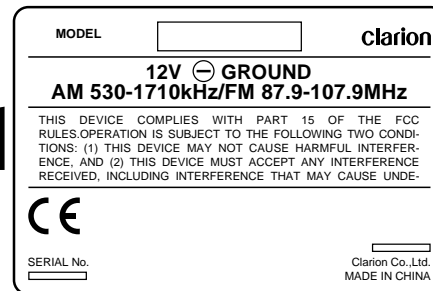

INFORMATION FOR USERS:

CHANGES OR MODIFICATIONS TO THIS PRODUCT WILL VOID THE WARRANTY AND WILL VIOLATE FCC APPROVAL.

2. FEATURES

Tuner

Electronic Quartz-Locked PLL Tuning
AM/FM Bands—1 AM, 3 FM
18 FM/6 AM Touchbutton Memory
Seek Up/Down Tuning
Preset Station Scan (PS)
Automatic Station Store (AS)
MAGI-TUNE® FM Reception System
Switchable Frequency Spacing

Tape

Auto Reverse
Locking FF/REW
Hard Permalloy Dual Gutter Head

Audio

Electronic Audio Controls (Volume/Bass/Treble/Balance/ Fader)
4-Way Balance Controls
140 W (35 W × 4) Maximum Power Output

General

Night Illumination
Digital Quartz Clock
Full Information LCD Display
Monitor Mode
Water Resistance Escutcheon
Wire Remote Control Capability

3.CONTROLS

Source Unit

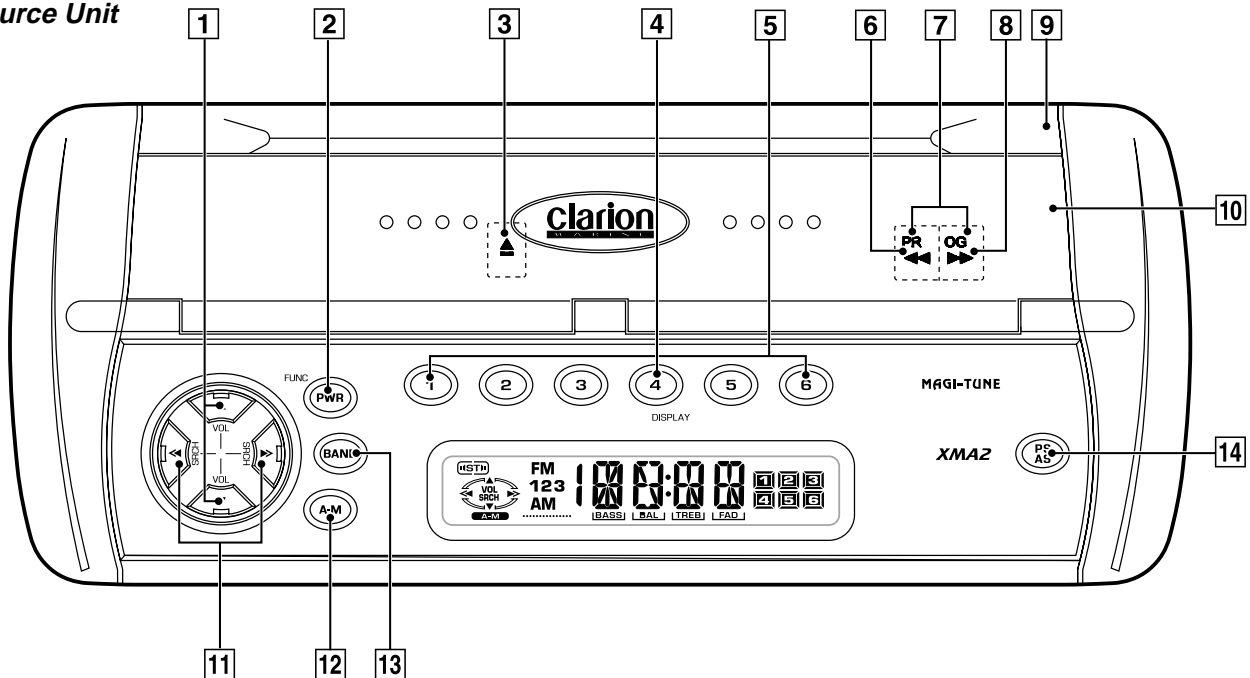

4.BUTTON TERMINOLOGY

- | | |
|-----------------------------------|--|
| 1 VOL (Volume) up and Down Button | 8 FF (▶▶) Button |
| 2 Power Button | 9 Hook |
| FUNC (Function) Button | 10 Door |
| 3 Eject (▲) Button | 11 SRCH (Search) Left and Right (◀◀ and ▶▶) Button |
| 4 Display Buttons | 12 A-M (Audio Mode) Button |
| 5 Preset Buttons (1 to 6) | 13 BAND Button |
| 6 Rew (◀◀) Button | 14 PS/AS (Preset Scan/Auto Store) Button |
| 7 PROG (Program) Button | |

5.CASSETTE PRECAUTIONS AND CARE





1. Tape slack can lead to operating difficulties. Remove tape slack before inserting a cassette, particularly when using C-90 or pre-recorded cassettes.
2. Use C-30 to C-90 cassettes. Avoid using C-120 or longer cassettes (The very thin tape may stretch or break).
3. Clean the head periodically with a good commercial head cleaner. Avoid touching the head with magnetic or hard objects.
4. Do not oil the cassette mechanism.
5. Always remove the cassette from the mechanism when not in use. Exposure to direct sunlight, extreme temperatures or high humidity may damage cassettes.

6. WIRED REMOTE CONTROL UNIT OPERATIONS

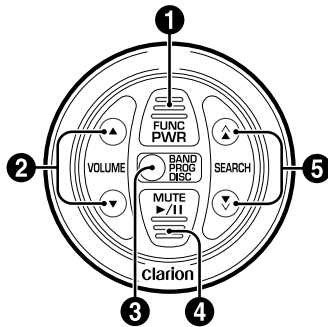
■ XMA2 following operations are enabled by remote control with the Wired Remote Control Unit M101RC (sold separately).

WIRED REMOTE CONTROL UNIT



- ❶ PWR (Power) Button
FUNC (Function) Button
- ❷ VOLUME Up (▲) / Down (▼) Buttons
- ❸ BAND Button []
- ❹ Play/Pause (▶/||) Button [],
MUTE Button []
- ❺ SEARCH Up (▲) / Down (▼) Buttons
[] : In Radio Mode
[] : In Tape Mode

PWR / FUNC Button ❶

Turning on and off the power

Press the PWR button ❶ to turn the power on and press and hold it for 1 second or longer to turn the power off.

Changing the operation mode

Each time the FUNC button ❶ is pressed, the mode switches in the following order:

Radio ↔ Tape

Note:

- In tape mode, if no cassette tape is loaded in XMA2, "CASS" flashes on the display and the radio mode is selected.

VOLUME Up (▲) / Down (▼) Buttons ❷

Adjusting the volume

Press the VOLUME Up button ❷ to increase the volume and press the VOLUME Down button ❷ to decrease the volume.

BAND Button ❸

Note:

- In tape mode, the BAND Button on the remote controller is inoperative.

Changing the band (in the Radio mode)

Each time the BAND button ❸ is pressed, the band switches in the following order:

FM1 → FM2 → FM3 → AM → FM1.....

Play/Pause (▶/||) / MUTE Button ❹

Pause (in Tape mode)

Press the Play/Pause button ❹. Playback pauses. To resume playback, press the Play/Pause button ❹ again.

Mute (in Radio mode)

Press the MUTE button ❹. The sound is muted immediately. To cancel, press the MUTE button ❹ again.

⚠ CAUTION

Be careful about adjusting the volume, as turning on the power while the volume is raised to its maximum may harm your hearing.

SEARCH Up (▲) / Down (▼) Buttons ❺

Note:

- In tape mode, the SEARCH UP (▲)/DOWN (▼) button on the remote controller is inoperative.

Changing preset stations (in the Radio mode)

Each time the SEARCH Up/Down buttons ❺ are pressed, the preset station switches in the following order:

1 → 2 → 3 → 4 → 5 → 6 → 1.....

or

6 → 5 → 4 → 3 → 2 → 1 → 6.....

7. OPERATION

Note:

- Be sure to read this chapter referring to the front diagrams of chapter 2. CONTROLS on page 3.

Basic Operations

▲ CAUTION

When this unit is turned on, starting and stopping the engine of a boat with its volume raised to the maximum level may harm your hearing.

Be careful about adjusting the volume.

IMPORTANT

Door must be totally closed to prevent water go into the set!

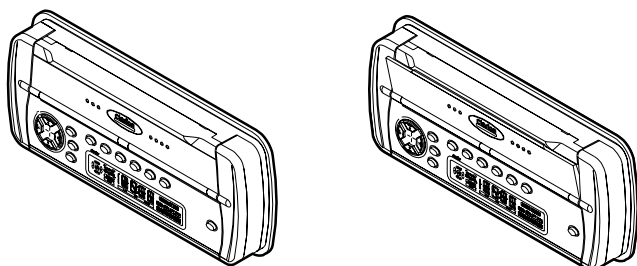

OK

NG

- 1) Press the POWER button [2].
 - * To turn the power off, press the POWER button for at least 1 second.
- 2) Press the FUNC button [2] to select another operation mode. The mode switches as follows each time the FUNC button is pressed:
Radio → Tape → Radio
 - * "CASS" appears when no tape is loaded in the unit.
- 3) Use the Up and Down buttons [1] to adjust the volume.
 - ▲: Increases the volume.
 - ▼: Decreases the volume.

Audio Mode Adjustments

- 1) Press the A-M button [12] to select the adjustment mode. The mode switches as follows each time the A-M button is pressed:
BASS/TREB → BAL/FAD → Previous mode
- 2) Use the Left and Right and the Up and Down buttons [11], [1] to adjust the bass and treble.
 - <Adjusting the bass>
 - : Bass gets stronger.
 - ◄◄: Bass gets weaker.
 - <Adjusting the treble>
 - ▲: Treble gets stronger.
 - ▼: Treble gets weaker.
- 3) Use the Left and Right and the Up and Down buttons [11], [1] to adjust the balance and fader.
 - <Adjusting the balance>
 - : Sound from right speakers gets stronger.
 - ◄◄: Sound from left speakers gets stronger.
 - <Adjusting the fader>
 - ▲: Sound from front speakers gets stronger.
 - ▼: Sound from rear speakers gets stronger.

Switching the Display

While pressing the BAND button [13], press the DISPLAY button [4] to enter the clock display mode.

Main display → Clock display → Main display

Setting the Clock

- 1) While pressing the BAND button [13], press the DISP button [4] to enter the clock display mode.
- 2) While pressing the BAND button [13], press and hold the DISP button [4] for 2 seconds or more. This enables the clock editing mode.
 - * The editable fields will be indicated when the display flashes.
- 3) To move between the hour and minute fields, use the left (hour) and right (minute) buttons [11].
- 4) To store the clock setting, press the BAND button [13].

Notes:

- If you select another operation mode before completing the above procedure, the clock setting operation will be canceled.
- Removing the vehicle's battery for a check or repair will cause the clock to reset to 1:00. Set the clock again if this happens.

Tape Operation

Loading Tapes

Open the door by push the hook.

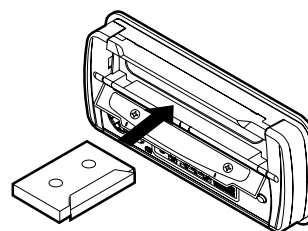

Insert the cassette tape into the Cassette insertion slot with the side on which the tape is exposed facing the right. Playback starts automatically.

- * When the end of the cassette tape is reached, the auto reverse mechanism is activated and the other side of the tape begins playing automatically.

Note:

- Fully insert the cassette tape into the cassette insertion slot.

Listening to a tape which is already loaded

Press the FUNC button [2] to select the tape mode. Playback begins automatically.

Ejecting Cassette Tapes

Open the door by push up the hook.

Press the Eject button [3]. The cassette tape is ejected.

- * The radio mode is selected automatically 4 seconds after ejecting the tape.

Fast-Forwarding and Rewinding

Use the FF button [8] and REW buttons [6].

►►: Press this to fast-forward the tape.

◄◄: Press this to rewind the tape.

- * It is possible to listen to the radio during fast-forward, rewind or search operations.

Switching to the Other Side of the Tape

Press the PROG button [7] both the FF button [8] and REW button [6] together at the same time. Playback is switched automatically to the other side of the cassette tape.

Radio Operation

FM Reception

For enhanced FM performance the **MAGI-TUNE**® tuner includes signal actuated stereo control and Multipath noise reduction circuits.

Listening to the Radio

- 1) Press the FUNC button [2] to select the radio mode. The radio turns on.
- 2) To tune to a desired preset station, first press the "BAND" button [13] and select FM1, FM2, FM3 or AM. The band changes as follows each time the "BAND" button is pressed:
FM1 → FM2 → FM3 → AM → FM1
- 3) Use the corresponding Preset buttons [5] to select the desired station.

Seek Tuning

- 1) Press the "BAND" button [13] and select the desired band.
- 2) The seek tuning mode is selected when "SRCH" is illuminated on the display.
- 3) Press the left or right buttons [11] to seek up or down the frequency band. Seek tuning automatically stops when a station is found.

Manual Tuning

- 1) Press the "BAND" button [13] to select the desired band.
- 2) Press and hold the "BAND" button for more than 2 seconds. "SRCH" turns off and the manual tuning mode is selected.
- 3) Use the Left and Right buttons [11] to manually tune up or down the desired frequency band.

Presetting Stations

A total of 24 stations can be preset, 6 each for the FM1, FM2, FM3 and AM bands.

Note:

- When a station is preset, the station previously stored in the memory at that position is cleared.

Presetting stations manually

- 1) Press the "BAND" button [13] to select the band at which to store the station.
- 2) Use the Left and Right buttons [11] to tune in the station to be preset.
- 3) Press and hold the corresponding Preset button [5] for at least 2 seconds to store the station into memory.

Auto store function (Automatic Station Store)

- 1) Press the "BAND" button [13] to select the band at which to store the stations.
- 2) Press and hold the AS button [14] for at least 2 seconds. Stations with good reception are automatically stored at preset to the six buttons [5] 1 to 6.

* If there are fewer than 6 stations with good reception, the stations previously stored at the remaining buttons are not cleared.

Preset Scanning (Preset Station Scan)

When the PS button [14] is pressed, the preset memory numbers flash and the stations are tuned in for 7 seconds each in the order in which they were stored. Press the PS button again to cancel the preset scanning mode.

Note:

- The auto store mode is set if the PS button is pressed for more than 2 seconds.

Area Change Function

Use this to listen to the radio outside of the United States.

Switchable frequency spacing

This boat stereo is initially set to tune in frequency intervals of 10 kHz for AM and 200 kHz for FM, the standard calibrations in the U.S. When using the unit outside the U.S., use the following procedure to switch the frequency steps and frequency range:

- 1) Turn the power on and set the tuner mode.
- 2) Keep the "BAND" button [13] pressed and while pressing the button, press the SRCH Left button [11].
- 3) Release the buttons.

This procedure changes the factory setting to 9 kHz steps for AM and 50 kHz steps for FM, the standard calibrations for countries other than the U.S.

To change the AM/FM setting back to the U.S. standard frequencies:

- 1) Set the tuner mode.
- 2) While pressing the "BAND" button [13], press the SRCH Right button [11].
- 3) Release the buttons.

Your boat stereo will once again be calibrated to receive standard U.S. transmissions.

The chart below lists the frequency specifications for the U.S. and other countries.

		Initial Setting (U.S. standard)	New Setting (outside U.S.)
AM	Frequency spacing	10 kHz	9 kHz
	Frequency range	530 to 1,710 kHz	531 to 1,629 kHz
FM	Frequency spacing	200 kHz	50 kHz
	Frequency range	87.9 to 107.9 MHz	87.5 to 108 MHz

8. TROUBLESHOOTING

Problem	Cause	Solution
Power does not turn on (or no sound is produced)	Fuse is blown.	Replace with a fuse of the same amperage as the old fuse.
	Connections are improper.	Read the attached "Installation/Wire Connection Guide" once again and wire properly.
Sound quality is poor.	Playback head is dirty.	Use a cleaning tape, etc. to clean the head.

9. SPECIFICATIONS

FM Tuner

Frequency Range : 87.9 MHz to 107.9 MHz
 Usable Sensitivity : 11 dBf
 50 dB Quieting Sensitivity : 17 dBf
 Alternate Channel Selectivity : 75 dB
 Stereo Separation (1 kHz) : 35 dB
 Frequency Response (± 3 dB) : 30 Hz to 15 kHz

AM Tuner

Frequency Range : 530 kHz to 1,710 kHz
 Usable Sensitivity : 25 μ V

Tape

Wow & Flutter (WRMS) : 0.1%
 Channel Separation (1 kHz) : 45 dB
 Signal to Noise Ratio : 120 μ s (normal): 52 dB
 Frequency Response (± 3 dB)
 120 μ s (normal) : 30 Hz to 16 kHz

Power Amplifier

Maximum Power Output : 140 W (35 W \times 4ch)
 Continuous Average Power Output :
 14 W \times 4, into 4 Ω , 20 Hz to 20 kHz, 1% THD

Pre-Amplifier

Bass Control Action (100 Hz) : ± 10 dB
 Treble Control Action (10 kHz) : ± 10 dB

General

Power Supply Voltage : 14.4 V DC (10.8 V to 15.6 V allowable)
 Current Consumption : Less than 10 A
 Speaker Impedance : 4 Ω (4 Ω to 8 Ω allowable)
 Weight : 2.91 lb. (1.8 kg)
 Dimensions :
 7" (178 mm) Width \times 2" (50 mm) Height \times 6" (152 mm) Depth
 Escutecheon Section:
 9" (232mm) width \times 4" (94mm) Height \times 1-1/2" (27mm) Thickness

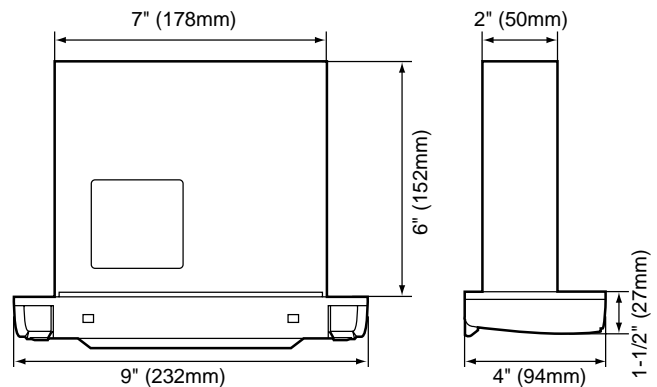

Note: Be sure to unfold this page and refer to the front diagram as you read each charters SOURCE UNIT

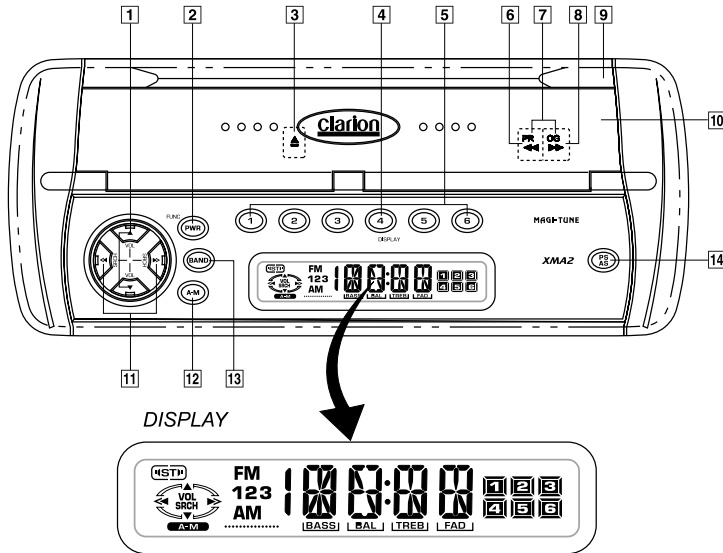

- 1 VOL (Volume) up and Down Button
- 2 Power Button
FUNC (Function) Button
- 3 Eject (▲) Button
- 4 Display Buttons
- 5 Preset Buttons (1 to 6)
- 6 Rew (◀) Button
- 7 PROG (Program) Button
- 8 FF (▶) Button
- 9 Hook
- 10 Door
- 11 SRCH (Search) Left and Right (◀ and ▶) Button
- 12 A-M (Audio Mode) Button
- 13 BAND Button
- 14 PS/AS (Preset Scan/Auto Store) Button

Note: After loading or ejecting Cassette, make sure the Door 10 is totally close!

Door open: Push up Hook 9 then Door 10 will open for loading or ejecting Cassette.

Button	Mode	Radio	Cassette
2	PWR FUNC	Turns power on and off. When pressed and held for 1 second: Turns power off. Switch between radio, Cassette.	
13	BAND	Switch reception band	
7	PROG		Switch to the other side of the tape.
1	VOLUME	Increases and decreases volume.	
11	SRCH	Seek up or down and stop at the station at which there is a broadcast will be selected.	
5	Display	When pressed Band with Display switch between operation mode and clock mode.	
12	A - M	Switches between Bass, Treble, Balance and Fader control.	
5	Preset	Recall the station stored before. When pressed and held for 2 seconds: Store the current station.	
14	PS/AS	Turns Preset Station on and off. When pressed and held for 2 seconds: Store the Station which the reception is the strongest automatically.	
6	REW		Press (◀) to rewind the tape.
8	FF		Press (▶) to fast-forward the tape.
3	Eject		Eject the Cassette tape.

IMPORTANT

DOOR MUST BE TOTALLY CLOSED TO PREVENT WATER GO INTO THE SET!

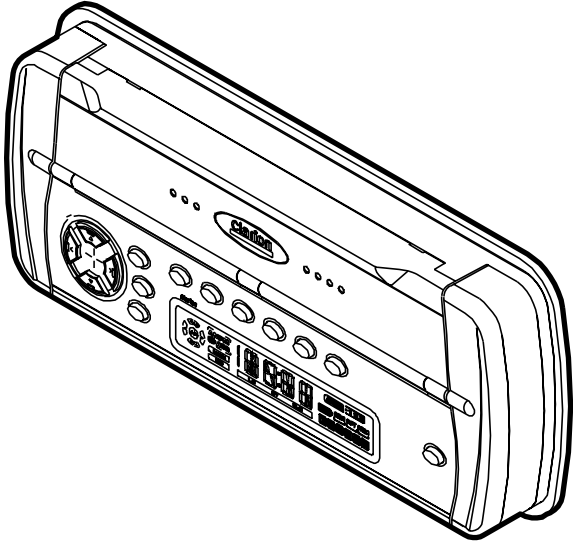

OK

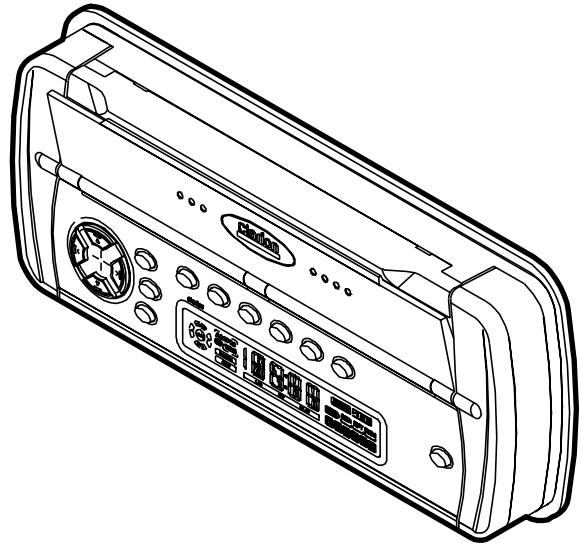

NG

**LOADING TAPES
OPEN THE DOOR BY PUSH THE HOOK.**

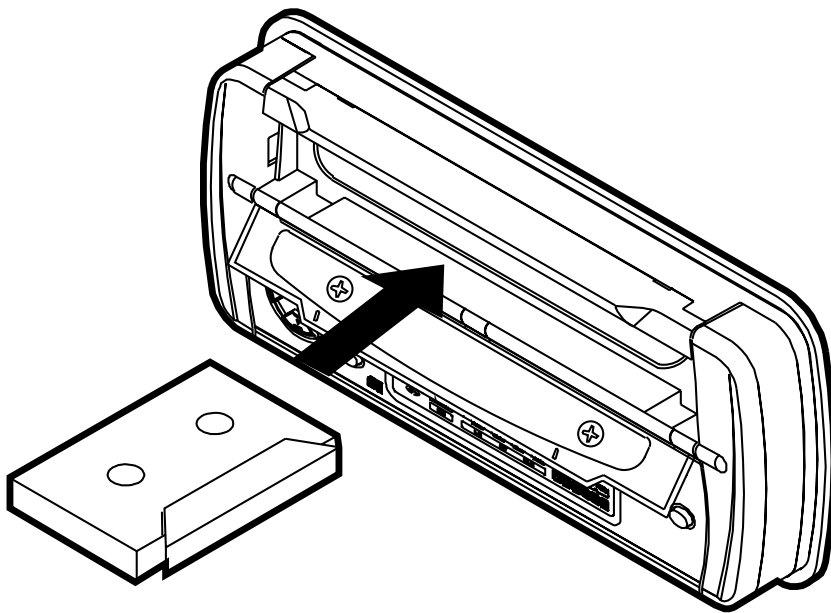

Clarion Co., Ltd.

All Rights Reserved. Copyright © 2000: Clarion Co., Ltd.
Printed in China

2000/3 (D•C)

PE-1691B
280-7482-00