

MODEL : SB 160

Stereo Cassette Player

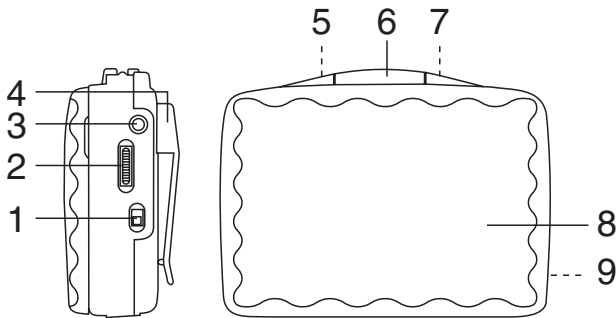

LOCATION OF CONTROLS



- | | |
|-----------------------------|--|
| 1. BBS(Bass Boost) Switch. | 6. PLAY Button. |
| 2. VOLUME Control. | 7. F.FWD (Fast Forward) Button. |
| 3. PHONES (Headphone) Jack. | 8. Cassette Door. |
| 4. Belt Clip. | 9. Battery Compartment (rear of unit). |

BATTERY INSTALLATION

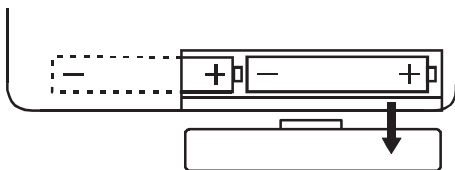

1. Open the battery compartment by sliding it down and insert two (2) "AA" size batteries (not included), following the polarity diagram.
2. Slide the battery compartment cover back into place.

BATTERY PRECAUTIONS

Follow these precautions when using batteries in this device:

1. Use only the size and type of batteries specified.
2. Be sure to follow the correct polarity when installing the batteries as indicated in the battery compartment. Reversed batteries may cause damage to the device.
3. Do not mix different types of batteries together. (e.g. Alkaline and Carbon-Zinc).
4. If the device is not be used for a long period of time, remove the batteries to prevent damage or injury from possible battery leakage.
5. Do not try to recharge batteries not intended to be recharged; they can overheat and rupture. (follow battery manufacturer's directions).

USING BASS BOOST SWITCH

To increase the Bass Response, slide the BBS(Bass Boost) switch to the "ON" position.

TO PLAY A PRERECORDED CASSETTE

- Insert a prerecorded tape with the open surface as shown.
- Close the Cassette Door and plug the headphone into the PHONES jack.
- Set the VOLUME control to minimum and press the PLAY button.
- Adjust the VOLUME and BBS(Bass Boost) switch as desired.
- To stop the tape before it reaches the end, press the STOP button.

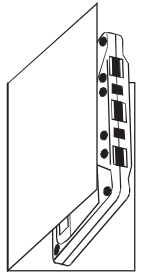

TO FAST FORWARD A TAPE

To rapidly advance the tape, press the F. FWD button. To rapidly advance the tape while in the Play mode, press the STOP button before pressing the F. FWD button.

TO REWIND A TAPE

To rewind an already played cassette tape, remove the tape from the compartment, flip it over to the other side, reinsert it in the compartment and press the F. FWD button. When you have forwarded it enough, press STOP, remove the cassette again and flip it over to the original side to repeat the played portion.

AUTOMATIC STOP

This cassette player has a built-in Automatic Stop System that stops the tape when it reaches the end in both the Play and F.Fwd modes.

CASSETTE TAPE USAGE

Longer length tapes of 60 (C-120) minutes of recording time on each side are not recommended. These tapes used thinner material and have a greater chance of malfunction, such as tape spillage from the cassette, internal binding and tape tearing. Use only high quality tapes. If there is any slack in the tape in the cassette, it should be removed before inserting the cassette. Place a pencil in one of the hubs and rotate toward the outside of the cassette until all slack is taken up.

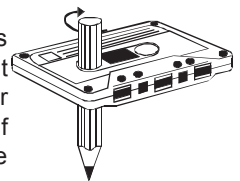

CARE AND MAINTENANCE

Clean the tape head, capstan and pinch roller using a cotton swab slightly moistened with alcohol. Avoid scratching the head surface. To clean the unit housing, use a soft cloth slightly dampened with water and wipe dry.

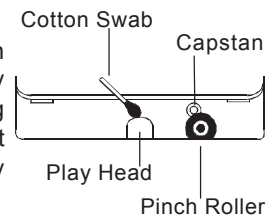

CAUTION: Never use chemicals such as benzene or paint thinner for cleaning, otherwise the case may be deformed or discolored.

TRAFFIC AND HEADSET SAFETY

- Do not use while operating a motorized vehicle. It may create a traffic hazard and is illegal in many areas.
- Even if your headset is an open air type designed to let you hear outside sounds, do not turn the volume up so high that you cannot hear what is around you.
- Use extreme caution or temporarily discontinue use in potentially hazardous situations.
- Do not play your headset at a high volume. Hearing experts advise against continuous extended play.
- If you experience a ringing in your ear, reduce volume or discontinue use.

EMERSON RADIO CORP. LIMITED WARRANTY

Emerson Radio Corp. warrants manufacturing defects in original material, including original parts and workmanship, under normal use and conditions, for a period of ninety (90) days from the date of original purchase in the U.S. With your dated proof of purchase, we will provide repair service at no charge for labor and parts at an authorized Depot Repair Facility, or replace the product in our discretion. For repair or replacement, pack your unit in a padded box, enclose your check or money order payable to Emerson Radio Corp. in the amount of \$5.00 (not required by California residents) to cover shipping and handling costs, and enclose a copy of your proof of purchase. Send your unit to:

Emerson Radio Corp.
1901 Diplomat Drive
Farmers Branch, TX 75234

This warranty does not cover damage from negligence, misuse, abuse, accident, failure to follow operating instructions, commercial use, rental, repairs by an unauthorized facility, or products purchased, used, serviced or damaged outside of the United States.

THIS WARRANTY GIVES YOU SPECIFIC LEGAL RIGHTS, AND YOU MAY ALSO HAVE OTHER RIGHTS WHICH VARY FROM STATE TO STATE.

Part no.: 21-2056
401-01

AU898H
Printed in China