

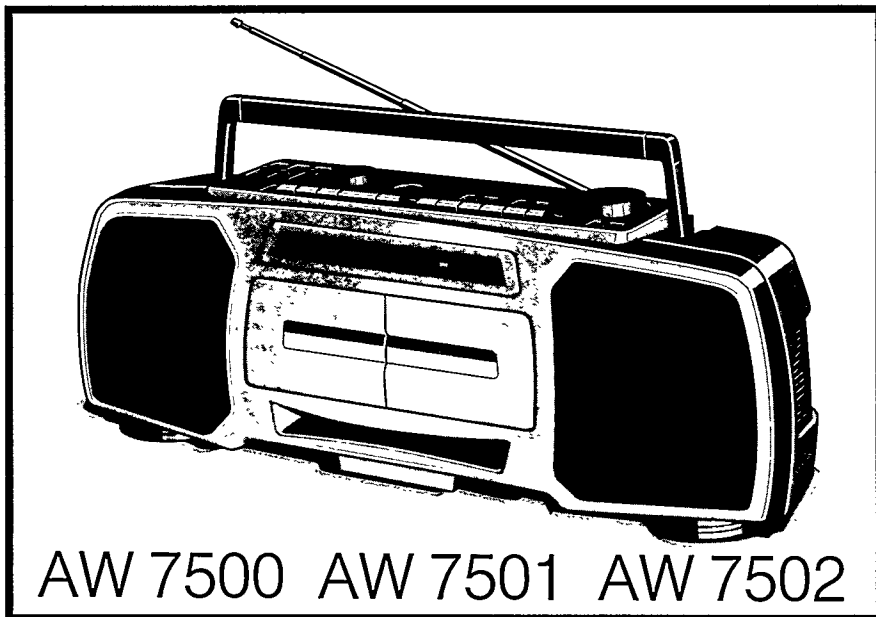

CONSUMER ELECTRONICS

# PHILIPS



|             |                                 |    |
|-------------|---------------------------------|----|
| <b>(GB)</b> | Stereo Radio Cassette Recorder  | 4  |
| <b>(F)</b>  | Radiocassette Stéréo            | 7  |
| <b>(D)</b>  | Stereo Radio-Cassetten-Recorder | 10 |
| <b>(NL)</b> | Stereo Radio-Cassetterecorder   | 13 |
| <b>(E)</b>  | Radiocasete Estéreo             | 16 |
| <b>(I)</b>  | Radioregistratore Stereo        | 19 |
| <b>(S)</b>  | Stereo Kassettradio             | 22 |
| <b>(SF)</b> | Stereoradionauhuri              | 24 |

**(GB) English** ..... page 4

Illustrations ..... page 3  
Guarantee and service ..... pages 28-29-30

**(F) Français** ..... page 7

Illustrations ..... page 3  
Garantie et service après-vente . . . pages 28-29-30

**(D) Deutsch** ..... Seite 10

Abbildungen ..... Seite 3  
Garantieleistung und Service . . . . . Seiten 28-29-30  
Amtsblatt ..... Seite 27

**(NL) Nederlands** ..... pagina 13

Afbeeldingen ..... pagina 3  
Garantie en service ..... pagina's 28-29-30

**(E) Español** ..... página 16

Ilustraciones ..... página 3  
Garantía ..... páginas 28-29-30

**(MEX) México** **NOM**

Es necesario que lea cuidadosamente su instructivo de manejo.

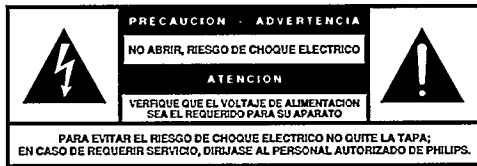

**NOM**

**(I) Italiano** ..... pagina 19

Illustrazioni ..... pagina 3  
Garanzia e servizio ..... pagine 28-29-30

**(S) Svenska** ..... sida 22

Figurer ..... sida 3  
Garanti och service ..... sidorna 28-29-30

**(SF) Suomi** ..... sivu 24

Kuvat ..... sivu 3  
Takuu ja huolto ..... sivut 28-29-30

**(DK) Danmark**

Typeskiltet findes på undersiden af apparaten.  
Dette produkt overholder kravene til radio-interferens af Europæisk Fællesmarked.

*Bemærk:* Netafbryderen MODE **(S)** er sekundært indkoblet og afbryder ikke strømmen fra nettet. Den indbyggede netdel er derfor tilsluttet til lysnettet så længe netstikket sidder i stikkontakten.

Garanti og service ..... sider 28-29-30

**(N) Norge**

Typeskilt finnes på apparatens underside.  
*Observer:* Nettbryteren MODE **(S)** er sekundært innkopleet. Den innebygde nettdelen er derfor ikke frakopleet nettet så lenge apparatet er tilsluttet nettkontakten.

Garanti og service ..... sider 28-29-30

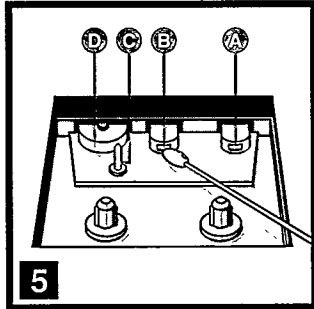
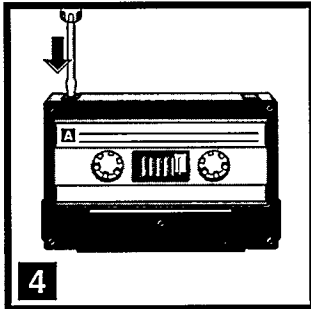
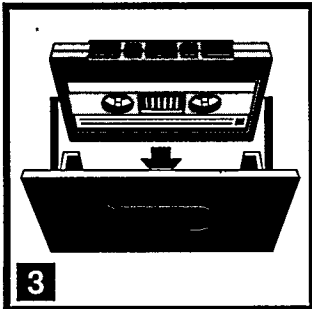
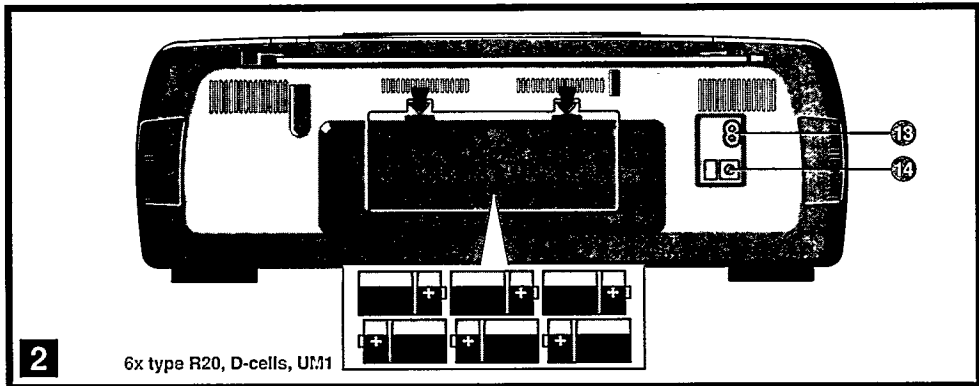
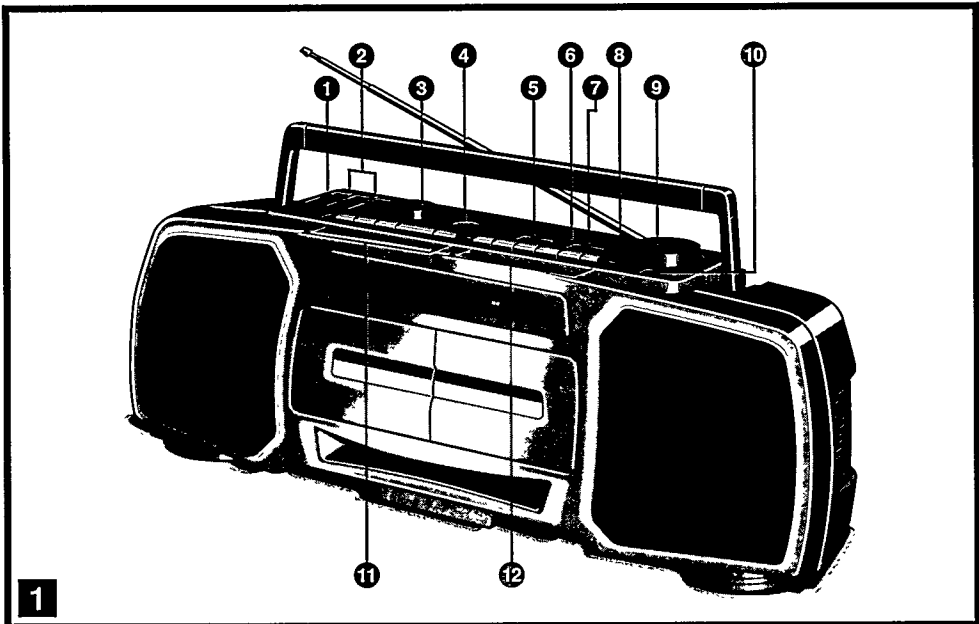

For the illustrations, keep page 3 open

## CONTROLS - figs. 1-2

- ① TBG bass control
- ② GRAPHIC EQUALIZER tone controls
  - 1 kHz (1 000 Hz) - mid-range
  - 10 kHz (10 000 Hz) - treble
- ③ VOLUME control with power on/off indicator
- ④ PHONES socket for stereo headphones
- ⑤ MODE selector - to select the sound source for reproduction or recording
- ⑥ built-in mono microphone MIC
- ⑦ DUBBING SPEED selector
- ⑧ FM STEREO indicator
- ⑨ TUNING knob
- ⑩ BAND selector
- ⑪ deck A keyboard, for playback only
  - PAUSE
  - F.FWD - fast forward wind
  - REWIND - fast rewind
  - PLAY
  - STOP/EJECT
- ⑫ deck B keyboard, recording and playback
  - PAUSE
  - F.FWD - fast forward wind
  - REWIND - fast rewind
  - PLAY
  - RECORD - record
  - STOP/EJECT
- ⑬ MAINS - socket for mains lead
- ⑭ VOLTAGE selector (*not on all versions*)  
*The type plate is located on the base of the set.*

## SUPPLY

### Battery supply

● Open the battery compartment (fig. 2) and insert as indicated six batteries, type R20, UM1 or D-cells.

#### **For the /07 and /17 versions only:**

*Instead of six batteries you can insert two 'Gates' rechargeable power sticks, size 3D. They require no separate recharger but are recharged automatically in this set whenever connected to a wall socket. Use only 'Gates' power sticks. Normal rechargeable D-cells cannot be recharged in this set.*

- Remove the batteries if exhausted or if they will not be used again for a long period.
- The battery supply is switched off if the mains lead socket MAINS ⑬ is occupied. To change over to battery supply, pull out the plug from the MAINS socket ⑬.

### Mains supply

● Check if the mains voltage as shown on the type plate corresponds to your local mains supply. If it does not, consult your dealer or service organisation.

*If the set is equipped with a VOLTAGE selector ⑭, set this selector to the local mains voltage.*

- Connect the mains lead to the MAINS socket ⑬ and the wall socket. The mains supply is now switched on.
- To disconnect the set from the mains completely, withdraw the mains plug from the wall socket.

#### **Important note for users in U.K.:**

*When fitting a mains plug to the mains lead proceed as follows: The wires in the mains lead are coloured in accordance with the following code: Blue = Neutral, Brown = Live. These colours may not correspond with the colour markings identifying the terminals in your plug, so proceed as follows:*

*Connect the Brown wire to the terminal marked L or coloured Red. Connect the Blue wire to the terminal marked N or coloured Black.*

*No connection is necessary to the earth terminal. Note: This apparatus must be protected by a 3 Amp Fuse if a 13 Amp plug is used or, if any other type of plug is used, by a 5 Amp Fuse either in the plug or adapter or at the distribution board. If in doubt consult a qualified electrician.*

## RADIO RECEPTION

- Set the MODE selector ⑤ to RADIO.
- Adjust the sound with the controls VOLUME ③, GRAPHIC EQUALIZER ② and TBG bass ①.

You may connect stereo headphones with 3.5 mm plug to socket PHONES ④. The loudspeakers are then muted.

- Select the wave band using BAND selector ⑩.
- Tune to a radio station using TUNING knob ⑨. (*SW and LW not on all versions*).

- For FM, pull out the telescopic aerial. To improve FM-reception, incline and turn the aerial. Reduce its length if the FM-signal is too strong (very close to a transmitter).
- For AM/MW and LW (Medium and Long Wave), the set is provided with a built-in aerial, so there is no need to use the telescopic aerial. The aerial can be directed by turning the whole set.
- For Short Wave (SW), the telescopic aerial must be pulled out and placed in the vertical position. To improve SW-reception, vary the length of the aerial.

● When the FM STEREO indicator ⑧ lights up, you are receiving a FM-stereo transmitter. A disturbing noise, due to a weak FM-stereo signal, can be suppressed by setting the BAND selector ⑩ to FM MONO. The FM STEREO indicator ⑧ will then go out and you will hear (*and record*) the FM programme in mono.

- To switch off the radio, set MODE selector ⑤ to MIC or TAPE.

## CASSETTE RECORDER

---

### Compact cassettes

For *recording*, use only NORMAL cassettes, IEC I. For *playback*, any cassette type can be inserted.

### Copyright

Recording is permissible insofar as copyright or other rights of third parties are not infringed.

*For U.K. only:* Recording and Playback of material may require consent. See Copyright Act 1956 and The Performer's Protection Acts 1958 to 1972.

### Fast winding and rewinding

Press fast forward wind F.FWD ◀◀ or REWIND ▶▶ button. To stop fast winding, press STOP button □.

### Safeguarding a cassette against erasure

Keep the cassette side to be safeguarded in front of you (fig. 4) and break out the left tab. Now, recording on this side is no longer possible.

You can render this safeguard ineffective by covering the aperture with a piece of adhesive tape.

## RECORDING (on deck B only)

---

### Preparation

– During recording, the deck A buttons should not be pressed.

- Press EJECT □ to open the cassette holder.
- Insert the cassette into deck B (fig. 3).

For recording, use a NORMAL cassette (IEC I) on which the tabs (fig. 4) are not broken out.

At the very beginning of the tape, no recording will take place during the first 7 seconds when the leader tape passes the recorder heads.

- When monitoring during recording, adjust the sound with the controls VOLUME ③, GRAPHIC EQUALIZER ② and TBG bass ①. These controls do not affect the recording.

### Recording from the radio

- Set MODE selector ⑤ to RADIO.
- In case of FM radio recordings, set the BAND selector ⑩ to FM MONO or STEREO.

### Mono recording from the microphone MIC ⑥

- Set MODE selector ⑤ to MIC.
- Set the VOLUME control ③ to zero (during microphone recordings, monitoring is not possible).

### Starting and stopping

- Start recording by pressing RECORD O; in doing so, PLAY ◀ is pressed too.
- For brief interruptions, press PAUSE ▯. To restart recording, press this button once more.

- To stop recording, press STOP □. On pressing again, the cassette holder will open.

- The set is switched off if MODE selector ⑤ is in position TAPE or MIC and the recorder buttons are released.

### DUBBING - Copying from deck A to B

– When copying, it is recommended to use fresh batteries or to connect the set to the mains.

– During dubbing, the deck A buttons F.FWD ◀◀ and REWIND ▶▶ should not be pressed.

- Set MODE selector ⑤ to TAPE.
- Set the DUBBING SPEED selector ⑦ to: NORMAL SPEED for normal speed copying; HIGH SPEED for high speed copying. Do not switch this selector during dubbing.
- Press both EJECT buttons □ and insert a recorded cassette into deck A and a cassette which is suited for recording into deck B (fig. 3).
- Press on deck B PAUSE ▯ and then RECORD O.
- To start dubbing, press PLAY ◀ on deck A.
- By pressing PAUSE ▯ of deck B, you can omit undesired passages while deck A continues, or you can insert another cassette in deck A and search for a particular passage on it. To restart copying, press PAUSE ▯ once more.
- Using PAUSE ▯ of deck A, deck B will record a blank part.
- To stop dubbing, press both STOP buttons □. The set is then switched off.

## CASSETTE PLAYBACK

---

### Playback on deck A or B

During playback, the tape in the other deck should not be fast forward wound or rewound, otherwise the actual cassette playback is affected.

- Set MODE selector ⑤ to TAPE.
- Press EJECT □ and insert a recorded cassette (fig. 3).
- Adjust the sound with the controls VOLUME ③, GRAPHIC EQUALIZER ② and TBG bass ①. You may connect stereo headphones with 3.5 mm plug to socket ④ PHONES ④. The loudspeakers are then muted.
- Press PLAY ◀ and playback will start.
- To stop playback, press STOP □. The set is then switched off.

### Continuous play

- Set MODE selector ⑤ to TAPE.
- Press both EJECT buttons □ and insert a recorded cassette into both decks (fig. 3).
- Press on deck A ◀ PLAY and playback will start.
- Then press on deck B PAUSE ▯ and PLAY ◀. As soon as deck A stops (at the end of the cassette or when its STOP button □ is pressed), deck B will start playing back.

- To stop playback, press STOP □. The set is then switched off.

## MAINTENANCE

---

### Cassette decks

To ensure a good recording and playback quality, clean the parts (A)(B)(C)(D) indicated in fig. 5 after every 50 hours of operation or, on average, once a month.

- Open the cassette holder by pressing EJECT □.
- Use a cotton bud slightly moistened with alcohol or a special head cleaning fluid.
- Press PLAY <I and clean the rubber pressure roller (D) (fig. 5).
- Then press PAUSE III and clean the capstan (C), recording/playback head (B) and erase head (A).
- After cleaning, press STOP □.

Cleaning of the heads (A) and (B) can also be done by playing the cleaning cassette SBC 114 through once as an ordinary cassette.

### Notes

- The recorder-mechanisms are fitted with self-lubricating bearings and therefore must not be oiled or greased.
- Do not expose the set, batteries and cassettes to rain, moisture, sand, or to excessive heat from e.g. heating equipment or in motor cars parked in the sun.
- Fingerprints, dust and dirt on the apparatus can be removed using a soft and clean, slightly damp leather cloth. Do not use any cleaning agents which contain abrasives or solvents such as benzine thinner, alcohol, refined petrol or ammonia, since they may affect and harm the cabinet.

This product complies with the radio interference requirements of the European Community.

#### GUARANTEE AND SERVICE FOR UNITED KINGDOM

Philips sell this product subject to the understanding that if any defect in manufacture or material shall appear in it within 12 months from the date of consumer sale, the dealer from whom the product was purchased will arrange for such defect to be rectified without charge, provided:

1. Reasonable evidence is supplied that the product was purchased within 12 months prior to the date of claim.

2. The defect is not due to use of the product for other than domestic purposes, or on an incorrect voltage, or contrary to the Company's operating instructions, or to accidental damage (whether in transit or otherwise), misuse, neglect or inexperienced repair.

Products sent for service should be adequately packed so no liability can be accepted for damage or loss in transit, and name and address must be enclosed.

#### Facts about free service

When service is required, apply to the dealer from whom the product was purchased. Should any difficulty be experienced in obtaining Service, e.g. in the event of the dealer having ceased to trade, you are advised to contact Philips Service.

**These statements do not affect the statutory rights of a consumer.**

If you have any questions which your dealer cannot answer, please write to **Philips Consumer Relations,**

☐ P.O. Box 298, 420 London Road, CROYDON CR9 3QR, or ☎ (01) 689-2166 Consumer Advice.

Please retain this card. Produce if service is required.

#### GUARANTEE AND SERVICE VALID FOR IRELAND

This apparatus is made of high quality material and great care has been taken in its manufacture.

Philips, therefore, give you a guarantee on parts against failures arising from faulty workmanship or material for 12 months after date of purchase. This guarantee is valid on the condition that this certificate is completed and signed immediately on delivery of the apparatus. In case of failure ask your dealer for further information.

If you have any questions which your dealer cannot answer, you may apply to **Philips Electrical (Ireland) Ltd., Service Department, Newstead, Clonskeagh, DUBLIN 14 - ☎ 69 33 55**

#### GUARANTEE AND SERVICE VALID FOR AUSTRALIA

The benefits given to the purchaser by this warranty are in addition to all other rights and remedies, which, under the Trade Practices Act or other Commonwealth or State law, the purchaser or owner has in respect of the product.

The Philips product carries the following warranties:

C-series HiFi-systems: 12 months. Compact Disc Players: 12 months. Home Audio Systems: 6 months. Clock radios, portable radios, cassette recorders, cassette players and radio recorders: 90 days. Any defect in materials or workmanship occurring within the specified period from the date of delivery, will be rectified free of charge by the retailer from whom this product was purchased.

**Note:** Please retain your purchase docket to assist prompt service.

#### Conditions of this warranty

1. All claims for warranty service must be made to the retailer from whom this product was purchased. All transport charges incurred in connection with warranty service or replacement will be paid by the purchaser.

2. These warranties do not cover batteries and extend only to defects in materials or workmanship occurring under normal use of the product where operated in accordance with our instructions.

**Philips Consumer Products Division, Technology Park, Flitree Drive, Australia Centre, HOMEBUSH 2140, New South Wales**

#### GUARANTEE AND SERVICE FOR NEW ZEALAND

Thank-you for purchasing this quality Philips product. The document you are now reading is your guarantee card.

#### Guarantee.

Philips New Zealand Ltd guarantees this product against defective components and faulty workmanship for a period of 12 months. Any defect in materials or workmanship occurring within 12 months from the date of purchase subject to the following conditions will be rectified free of charge by the retailer from whom this product was purchased.

#### Conditions.

1. The product must have been purchased in New Zealand, and this guarantee card completed at time of purchase (this is your proof of the date of purchase).

2. The guarantee applies only to faults caused by defective components, or faulty workmanship on the part of the manufacturer.

3. The guarantee does not cover failures caused by misuse, neglect, normal wear and tear, accidental breakage, use on the incorrect voltage, use contrary to operating instructions, or unauthorised modification to the product or repair by an unauthorised technician.

4. Reasonable evidence (in the form of a sales docket or completed guarantee card) must be supplied to indicate that the product was purchased no more than 12 months prior to the date of your claim.

5. In the event of a failure, Philips shall be under no liability for any injury, or any loss or damage caused to property or products other than the product under guarantee.

**This guarantee does not prejudice your rights under common law and statute, and is in addition to the normal responsibilities of the retailer and Philips.**

#### How to claim.

Should your Philips product fail within the guarantee period, please return it to the retailer from whom it was purchased. In most cases the retailer will be able to satisfactorily repair or replace the product.

However, should the retailer not be able to conclude the matter satisfactorily, or if you have other difficulties claiming under this guarantee, please contact: **The Guarantee Controller, Philips New Zealand Ltd, ☐ P.O. Box 1041, AUCKLAND - ☎ (09) 605-914**

#### GARANTIE FÜR DIE BUNDESREPUBLIK DEUTSCHLAND UND WEST-BERLIN

Philips-Geräte sind Markenartikel, die mit größter Präzision nach modernsten Fertigungsmethoden und mit einem Höchstmaß an Sorgfalt hergestellt werden. Das Gerät wird Ihnen gute Dienste leisten, vorausgesetzt daß Sie es sachgemäß bedienen und unterhalten. Trotz aller Sorgfalt ist das Auftreten von Fehlern nicht auszuschließen. Ihr Partner für die Behebung derartiger Fehler ist Ihr Fachhändler, bei dem das Gerät erworben wurde. Falls ein Reklamationsfall eintritt, wenden Sie sich bitte unter Vorlage des Einkaufsbeleges und des Gerätepasses an Ihren Fachhändler.

#### GARANTIE ET SERVICE APRÈS-VENTE EN FRANCE

Cet appareil a été fabriqué avec le souci de vous donner entière satisfaction. PHILIPS fournira gratuitement au vendeur les pièces détachées nécessaires à sa réparation pendant les périodes suivantes, chacune prenant effet à compter de la date de vente:

- 6 mois pour les magnétophones à cassettes portatifs, les récepteurs radio portatifs, les radiocassettes et les radio-réveils;
  - 12 mois pour les radiocassettes équipés de la fonction Compact Disc et les baladeurs Compact Disc,
  - 12 mois pour les appareils entrant dans la composition d'une chaîne électro-acoustique, y compris les chaînes compactes stationnaires équipés d'au moins deux sources sonores;
- sauf si la détérioration résulte d'une cause étrangère à l'appareil ou du non respect des prescriptions d'utilisation.

Vous bénéficiez en tout état de cause des dispositions des art. 1641 et suivants du Code Civil relatifs à la garantie légale

Pour tout conseil ou intervention, adressez-vous à votre vendeur. Pour tout renseignement complémentaire, vous pouvez vous adresser à la succursale Philips la plus proche.

Soucieux d'améliorer continuellement la qualité de nos produits, nous nous réservons le droit d'en modifier à tout moment les caractéristiques.

**PHILIPS Électronique Domestique - Société en nom collectif**

**RCS NANTERRE B 333 760 833**

**64, Rue Camot - ☐ B.P. 306 - 92 156 SURESNES Cédex**

**Informations Consommateurs: ☎ (16-1) 64 80 54 54**

#### GARANTIE EN BELGIQUE ET LUXEMBOURG

Pour les conditions de garantie en Belgique et Luxembourg veuillez vous référer à la carte de garantie que le revendeur doit vous remettre au moment de l'achat.

#### ● Pour la Belgique

Si après l'achat de l'un ou l'autre appareil Philips vous avez des problèmes concernant par exemple la garantie, le fonctionnement ou l'utilisation de ces appareils et que le distributeur qui vous a vendu ces appareils éprouve des difficultés pour les résoudre, prenez contact, soit par téléphone, soit par écrit avec notre service

**'Contact Clientèle', Place de Brouckère 2, 1000 - BRUXELLES**

**☎ 02/211 91 11**

#### GARANTIE EN SERVICE IN BELGIË EN LUXEMBURG

In België en Luxemburg gelden uitsluitend de garantiebepalingen zoals die in het via uw handelaar apart verstrekte garantiebewijs staan aangegeven.

#### ● Voor België

Indien u na de aankoop van een of ander Philips apparaat problemen heeft met bijv. de waarg. of de werking, of het gebruik ervan, en indien de verdeler die u deze apparaten verkocht heeft moeilijkheden ondervindt om deze problemen op te lossen, stelt u zich dan telefonisch of schriftelijk in verbinding met onze dienst

**'Klanten Kontakt', de Brouckereplein 2, 1000 - BRUSSEL**

**☎ 02/211 91 11**

## GARANTIE EN SERVICE IN NEDERLAND

### ● Wat wordt gegarandeerd?

Philips Nederland B.V. garandeert dat dit apparaat kosteloos wordt hersteld indien - bij normaal particulier gebruik volgens de gebruiksaanwijzing - binnen 12 maanden na aankoopdatum fabricage- en/of materiaalfouten optreden.

### ● Wie voert de garantie uit?

De zorg voor de uitvoering van de garantie berust bij de handelaar die u het apparaat verkocht heeft. De handelaar kan daarbij eventueel een beroep doen op een der Philips Service vestigingen.

### ● Uw aankoopbon + de Identificatiekaart

De identificatiekaart is uw garantiebewijs. U kunt alleen een beroep doen op de bovenschreven garantie tegen overlegging van de aankoopbon (factuur, kassabon of kwitantie), in combinatie met de identificatiekaart, waarop typenummer en serienummer zijn vermeld. Uit de aankoopbon dienen duidelijk de aankoopdatum en de naam van de handelaar te blijken. Mocht het noodzakelijk zijn deze documenten aan uw handelaar af te geven, dan kunt u hem daarvoor een ontvangstbewijs vragen. De garantie vervalt indien op de genoemde documenten iets is veranderd, doorgehaald, verwijderd of onleesbaar gemaakt. De garantie vervalt eveneens indien het typenummer en/of serienummer op het apparaat is veranderd, doorgehaald, verwijderd of onleesbaar gemaakt.

### ● Hoe te handelen bij een storing?

Om onnodige kosten te voorkomen, raden wij u aan bij storingen eerst nauwkeurig de gebruiksaanwijzing te lezen. Indien de gebruiksaanwijzing daarin geen uitkomst biedt, kunt u uw handelaar raadplegen en/of hem het apparaat ter reparatie aanbieden.

### ● ...en bij problemen?

Bij problemen omtrent de garantie-uitvoering kunt u zich in verbinding stellen met **Philips Nederland B.V., Afdeling Consumentenbelangen, Antwoordnummer 500 - 5600 VB EINDHOVEN** (postzegel niet nodig), of **042 040-78 11 78**.

## GARANTIE FÜR DIE SCHWEIZ

Philips-Geräte sind aus einwandfreiem Material und mit großer Sorgfalt hergestellt worden. Dieses Gerät wird Ihnen gute Dienste leisten, sofern es sachgemäß bedient und unterhalten wird.

Trotz aller Sorgfalt ist das Auftreten von Fehlern nicht ganz auszuschließen. Im Falle eines Defektes wenden Sie sich bitte unter Vorlage des Einkaufsbeleges und des Gerätepasses an das Fachgeschäft, in welchem Sie das Gerät erworben haben.

## GARANTIE POUR LA SUISSE

Les appareils Philips ont été fabriqués au moyen de matériaux de toute première qualité et avec beaucoup de soins. Cet appareil vous donnera encore plus de satisfaction si l'utilisation et l'entretien sont suivis selon le mode d'emploi.

Malgré tous les soins apportés, l'apparition de défauts n'est pas exclue. Dans ce cas, nous vous serions reconnaissants de bien vouloir vous adresser directement chez votre vendeur muni du passeport de l'appareil ainsi que de la facture s'y reportant.

## GARANZIA PER LA SVIZZERA

Gli apparecchi Philips sono prodotti con materiali di prima qualità e assemblati con la massima cura. Essi Vi offriranno un ottimo servizio, in cambio di un accurato uso e manutenzione.

Malgrado tutti i nostri sforzi, non è escluso che possano avvenire dei guasti. In caso di difetto Vi preghiamo di rivolgerVi al Vostro fornitore specializzato, portando con Voi il passaporto assieme ai documenti d'acquisto.

## GARANZIA E ASSISTENZA VALIDE PER L'ITALIA

Questo apparecchio è stato realizzato con materiali di prima qualità e costruito con la massima cura. La Philips comunque fornisce all'acquirente una Garanzia di buon funzionamento secondo le condizioni stabilite dall'ANIE.

Tale Garanzia decore dalla data di acquisto ed ha la durata di **6 mesi**. Per aver diritto alla Garanzia è necessario che questo certificato riporti i dati di Modello e Matricola dell'apparecchio, la data di acquisto ed il timbro del rivenditore; inoltre per tutti gli apparecchi per i quali è prevista la "ricevuta fiscale" (o altro documento di consegna) il documento stesso dovrà essere conservato con questo certificato a certificazione della data d'acquisto.

In caso di necessità il prodotto dovrà essere fatto pervenire al Centro di Assistenza più vicino il cui recapito è pubblicato sugli elenchi telefonici della zona di residenza alla voce Philips.

Per questo apparecchio Philips offre un Abbonamento all'Assistenza Tecnica. Per informazioni rivolgersi ai Centri di Assistenza o al servizio Consumatori Philips.

**Philips S.p.A., Viale le Fulvio Testi 327, 20162 MILANO**  
**☎ 1678-20026**

## GARANTIE IN ÖSTERREICH

In Österreich ist die Gewährleistung für Verträge zwischen Händler und Käufer gesetzlich geregelt. Zur Geltendmachung eines Gewährleistungsanspruches dient der Kaufbeleg.

Die Österreichische Philips Industrie GmbH unterstützt die Gewährleistungsverpflichtung Ihres Händlers für Neugeräte, die der Handel über die Österreichische Philips Industrie GmbH bzw. Horny Vertriebsgmbh bezogen hat, dadurch, daß für den Käufer innerhalb von 6 Monaten ab Verkaufsdatum Funktionsmängel (Fabrikations- oder Materialfehler) in einer unserer Service-Filialen kostenlos, d.h. ohne Verrechnung von Arbeitszeit und Material, behoben werden. Schäden, die durch äußere Einflüsse, unsachgemäße Behandlung oder unsachgemäßen Fremdeingriff entstanden sind, sowie Gehäusefehler oder Glasbruch, sind von dieser Zusage ausgeschlossen.

### Philips Zentrale Kundeninformation:

– 1101 WIEN, Triesterstraße 64,

☎ 0222-60101-DW 1620 oder DW 1563

– 6020 INNSBRÜCK, Klostergasse 4, ☎ 05222-74694

– 9020 KLAGENFURT, Villacher Straße 161,

☎ 0463-22397-DW 94

### Philips Service-Organisation:

– 1232 WIEN, Ketzergasse 120, ☎ 0222-8662-0

## PHILIPS IBÉRICA, S.A.E.

Garantía este aparato durante 6 meses, a partir de la fecha de adquisición, de la forma siguiente:

1. Cubriendo cualquier defecto de fabricación o vicio de origen, así como la totalidad de sus componentes, incluyendo la mano de obra necesaria para el reemplazo de las piezas defectuosas, por nuestros talleres autorizados.
2. Esta garantía no cubrirá la avería, si es consecuencia de incorrecta instalación del aparato, manifiesto mal trato o uso inadecuado del mismo. La calificación de las averías responderá únicamente a los servicios técnicos de los talleres autorizados Philips.
3. Las reparaciones que pudieran producirse durante el período de vigencia de la presente garantía se efectuarán, bien en el domicilio del usuario, bien en los talleres autorizados Philips, a libre elección y criterio de ésta última.
4. Transcurrido un mes desde la fecha de adquisición del aparato, todos los gastos de desplazamiento del personal técnico para proceder al examen y/o reparación del aparato correrán por cuenta del usuario de acuerdo con las tarifas establecidas para este concepto.
5. En todas las reparaciones se deberá acompañar al aparato factura de compra y la presente garantía debidamente cumplimentada, con la indicación exacta de la fecha de venta del aparato.
6. En todo caso, el titular de la garantía tiene los derechos mínimos reconocidos por la Ley.

Titular (Comprador) .....

Domicilio .....

## GARANTÍA PARA MÉXICO

Este aparato está fabricado con materiales de alta calidad y ha sido cuidadosamente verificado. Philips, por lo tanto, da a usted una garantía de 12 meses a partir de su fecha de compra.

La garantía ampara la reposición de las piezas defectuosas debidas a fallas en su montaje o en los materiales, incluyendo la mano de obra necesaria para su reemplazo en nuestras Sucursales o talleres autorizados.

En caso de fallas en su aparato le rogamos se sirva poner en contacto con su distribuidor.

Esta garantía no cubrirá las averías que resulten como consecuencia de una instalación incorrecta del aparato, manifiesto maltrato o uso inadecuado del mismo.

Philips se obliga a reparar y devolver a usted su aparato en un plazo no mayor de 30 días hábiles contados a partir de la fecha de haber ingresado su aparato a uno de nuestros talleres.

Para que esta garantía sea válida, es necesario que el certificado que figura en la parte posterior de este instructivo haya sido debidamente llenado en el momento de la compra del aparato.

En caso de extravío del certificado con la presentación de la factura o remisión de su aparato podrá hacer efectiva la garantía correspondiente.

Si usted tiene alguna duda o pregunta que no le pueda solucionar su distribuidor, por favor ponerse en contacto con:

**Oficinas Centrales de Servicio**  
**Av. Coyoacán No. 1051, Col. del Valle**  
**03100 MÉXICO, D.F. ☎ 5-75-20-22 o 5-75-01-00**

**IBM**

09-89



