

FLUID REGULATOR



READ THIS MANUAL CAREFULLY BEFORE INSTALLING,
OPERATING OR SERVICING THIS EQUIPMENT.

STANDARD CAPACITY STAINLESS STEEL DOWNSTREAM TYPE

MAXIMUM INLET PRESSURE 750 PSI (51.7 BAR)
1/4" INLET/OUTLET
THIS MANUAL COVERS THE FOLLOWING MODELS

5-125 PSI WORKING RANGE	0-50 PSI WORKING RANGE	10-250 PSI WORKING RANGE	0-30 PSI WORKING RANGE
27520-000	27520-100	27520-200	27520-400
27521-000	27521-100	27521-200	27521-400
27522-000	27522-100	27522-200	
		27521-300	

SERVICE KITS

Use only genuine ARO replacement parts to assure compatible pressure rating.

OPERATION

To adjust back pressure, turn Y23-72-B screw clockwise with Y106-105 allen wrench which is furnished with unit. To decrease pressure, turn Y23-72-B screw counterclockwise. (Does not apply to Model 27521-300.) To adjust pressure on Model 27521-300, regulate air pressure to back side of diaphragms using auxiliary port on 104135 cap.

SERVICE HINTS

- If outlet pressure rises or creeps, check (D) seat assembly and (F) ball for foreign material. If (D) seat assembly and (F) ball appear to be worn or eroded, they should be replaced. (See Figure 2)
- If material is leaking through bleed hole in 29919 housing and nut assembly, replace 29000 and 90860 diaphragms. (Does not apply to Model 27521-300.)

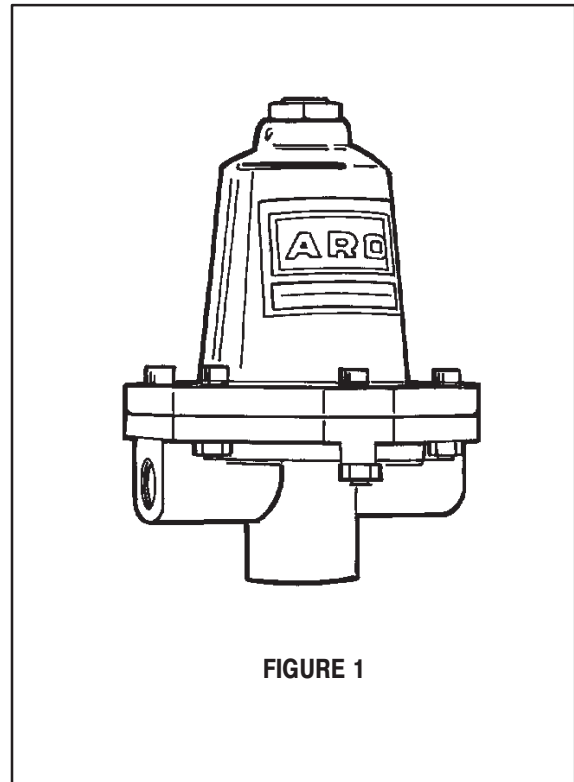

FIGURE 1

OPERATING AND SAFETY PRECAUTIONS

- Read and heed all Warnings, Cautions, and Safety Precautions before operating this pump.
- Use only genuine ARO replacement parts to assure compatible pressure rating and longest service life.
- **⚠️ WARNING MISAPPLICATION HAZARD** DO NOT USE A REGULATOR WHERE THE FLUID INLET PRESSURE IS TOO HIGH FOR THE DESIGNED OPERATING RANGE.
- **⚠️ WARNING HIGH PRESSURE DEVICE** IMPROPER USAGE OF THIS EQUIPMENT COULD RESULT IN SERIOUS INJURY. The possibility of injection into the flesh is a potential hazard. Wear approved safety glasses or face shield any other equipment as needed to prevent injury. Never allow any part of the human body to come in front of or in direct contact with the material outlet, the tip, or the material outlet of the dispensing device. An injection injury can be serious. If an injection accident should occur, it is very important that you contact a qualified physician for immediate treatment.
- **⚠️ WARNING COMPONENT RUPTURE** DO NOT OPERATE REGULATOR AT AN INLET PRESSURE GREATER THAN SPECIFIED. To avoid possible damage or personal injury DO NOT operate this unit at pressure higher than the stated operating range as appears on the model plate.
- **⚠️ WARNING HAZARDOUS AIR PRESSURE** CAN RESULT IN SERIOUS INJURY. DO NOT SERVICE OR CLEAN PUMP, HOSES OR DISPENSING VALVE WHILE THE SYSTEM IS PRESSURIZED. First disconnect air line, then relieve pressure from the system by opening dispensing valve or device and/or carefully and slowly loosening and removing outlet hose or piping from pump.
- **⚠️ WARNING DISASSEMBLY HAZARD** DO NOT DISASSEMBLE THIS REGULATOR WHEN IT IS UNDER PRESSURE. RELIEVE ALL MATERIAL PRESSURE IN THE PUMPING SYSTEM BEFORE ATTEMPTING SERVICE OR DISASSEMBLY PROCEDURES. Disconnect air lines and carefully bleed off of the system. Be certain the system is not maintaining pressure due to a material restriction in the hose line, dispensing device, or the spray or extrusion tip. Failure to relieve pressure both up stream and downstream may result in an injury upon disassembly.
- **⚠️ WARNING BONNET REMOVAL HAZARD** DO NOT ATTEMPT TO REMOVE THE BONNET RETAINING BOLTS WITHOUT FIRST RELIEVING THE TENSION ON THE MAIN SPRING. Failure to relieve tension could result in an accident upon disassembly.
- **⚠️ WARNING PREVENT FIRES** KEEP SOLVENTS AWAY FROM HEAT, SPARKS, OR OPEN FLAME. Keep containers closed when not in use. When pumping, flushing or recirculating volatile solvents be certain the area is adequately ventilated.
- **⚠️ CAUTION FLUSH SUPPLY LINE** Before installing fluid regulator blow the supply lines clear and flush to remove contaminants.

DISASSEMBLY

1. Unscrew the Y154-54-C and Y154-56-C screws from the Y22-10-C nuts.
2. Lift the 29919 housing and nut assembly from the 29446 base.
3. Remove the 29273 spring cap and (B) spring. (For Model 27521-300, unscrew the Y154-54-C and Y154-56-C screws from the 104135 cap. Also remove Y14-10-C lockwashers.)
4. The 29000 and 90860 diaphragms are now accessible. Unscrew (D) seat assembly from the 29446 base. This provides access to (D) seat assembly and 29449 seal and 29451 spring.

REASSEMBLY

1. Place 29451 spring in 29446. Set (F) ball on top of spring. Use new 29449 seal, place it on 29446 base.
2. Screw (D) seat assembly into 29446 base and tighten to 20 ft. lbs.
3. To assemble diaphragm place 29000 and 90860 diaphragms together. Place 90860 diaphragm next to the hex over the threaded end of the (E) pushrod.
4. Apply Loctite 242 to threads on (E) pushrod. Screw (E) pushrod into (C) back-up plate and tighten, making sure all holes in the diaphragms align. Align holes in diaphragms with holes in base.
5. Place 29919 housing and nut assembly on the 29000 diaphragm.
6. Insert Y154-54-C and Y154-54-C screws through the holes in the 29919 housing and nut assembly.
7. Place Y22-10-C nuts on screws and tighten. (For Model 27521-300, assemble 104135 cap to 29446 base using Y154-54-C and Y154-56-C screws. Also include Y14-10-C Lockwashers.

27520-XXX
27521-XXX
27522-XXX

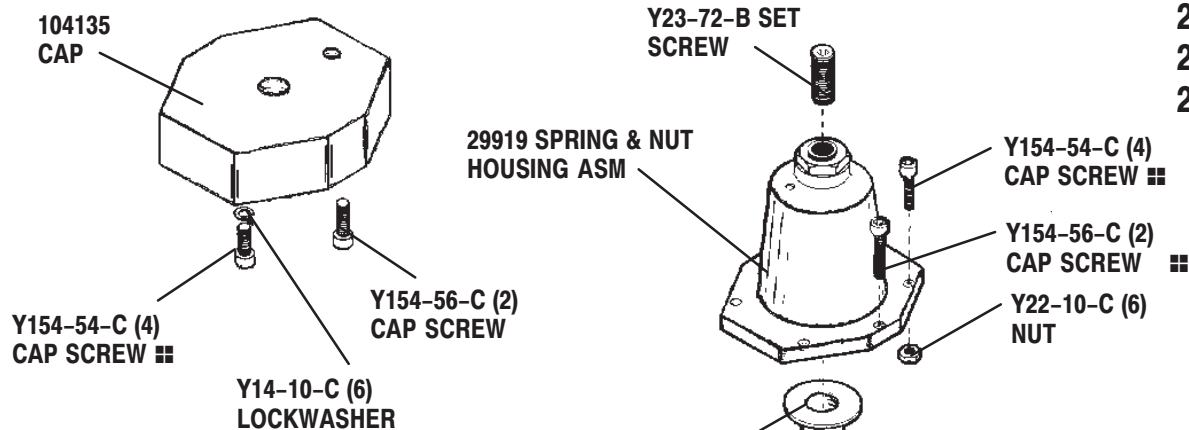

MODEL 27521-300 ONLY

29273 SPRING CAP

FIGURE 2

29000 DIAPHRAGM

90860 DIAPHRAGM

■ TORQUE TO 45 ±5 IN. LBS

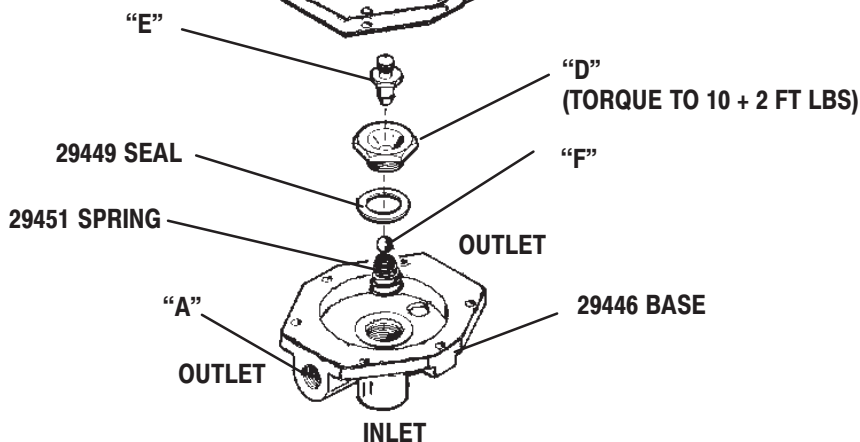

NOTE: INCLUDED BUT NOT SHOWN
Y106-105 ALLEN WRENCH

PARTS LIST

MODEL #	"A" PORT	"B" SPRING	"C" PLATE	"D" SEAT	"E" ROD	"F" BALL	BALL MATL.
27520-000	1/4 N.P.T.F.	29002 (5-125)	29001	29981	29983	29254	T'CARBIDE
27520-100	1/4 N.P.T.F.	29119 (0-50)	29001	29981	29983	29254	T'CARBIDE
27520-200	1/4 N.P.T.F.	29120 (10-250)	29155	29981	29983	29254	T'CARBIDE
27520-400	1/4 N.P.T.F.	93998 (0-10)	29001	29981	29983	29254	T'CARBIDE
27521-000	1/4 N.P.T.F.	29002 (5-125)	29001	29982	29447	Y16-108	S'STL
27521-100	1/4 N.P.T.F.	29119 (0-50)	29001	29982	29447	Y16-108	S'STL
27521-200	1/4 N.P.T.F.	29120 (10-250)	29155	29982	29447	Y16-108	S'STL
27521-300	1/4 N.P.T.F.	—————	29001	29982	29447	Y16-108	S'STL
27521-400	1/4 N.P.T.F.	93998 (0-10)	29001	29982	29447	Y16-108	S'STL
27522-000	1/4 N.P.T.F.	29002 (5-125)	29001	29982	29447	29253	RUBBER
27522-100	1/4 N.P.T.F.	29119 (0-50)	29001	29982	29447	29253	RUBBER
27522-200	1/4 N.P.T.F.	29120 (10-250)	29155	29982	29447	29253	RUBBER

