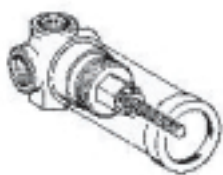
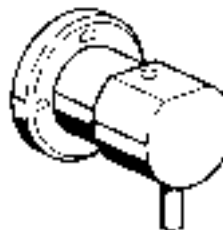
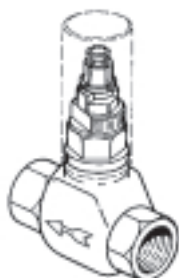

Faucets for the Bath and Shower rooms
Robinetterie pour le bain et pour la douche
Griferia para el baño y ducha
KWC DESIGNO
KWC LUX
KWC LUX-STYLE
**K.38.H4.70.931****K.27.L3.70****K.27H3.70****K.27.L3.70**
K.38.93.00.931.2210 1/2"
K.38.93.00.931.1710 3/4"
**K.27.L3.70****K.27.H3.70****K.27.L3.70**

E Operating data
 Ideal operating pressure : 3 bar (45 PSI)
 Max. operating pressure : 5 bar (70 PSI)
 Ideal water temperature : 60 °C (140°F)
 Max. water temperature : 90 °C (190°F)

F Caractéristiques de fonctionnement
 Pression de service idéale : 3 bar
 Pression de service max. : 5 bar
 Température idéale de l'eau : 60 °C
 Température max. de l'eau : 90 °C

Sp Características de funcionamiento
 Presión ideal de servicio : 3 bar
 Presión máxima de servicio : 5 bar
 Temperatura ideal del agua : 60 °C
 Temperatura máxima del agua : 90 °C

Before installation flush pipes thoroughly!

Rincer à fond la tuyauterie avant le montage!

Limpiar escrupulosamente las tuberías antes del montaje!
Schweiz, Suisse:
 KWC AG
 Hauptstrasse
 CH-5726 Unterkulm

USA:
 KWC Faucets Inc.
 1770 Corporate Drive # 580
 Norcross, GA 30093

 Tel. : 062 768 67 77
 Fax : 062 768 61 69

 Tel. : 678 334 2121
 Fax : 678 334 2128

K.38.93.00.931

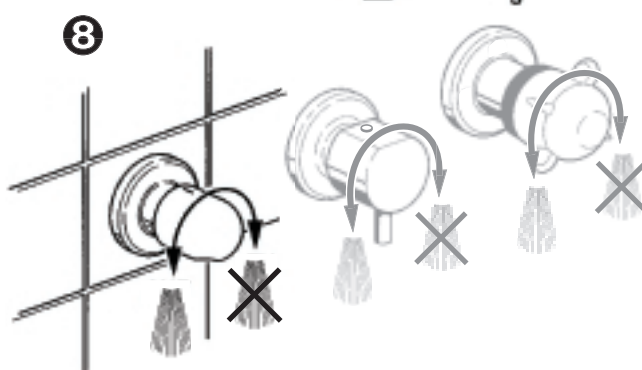
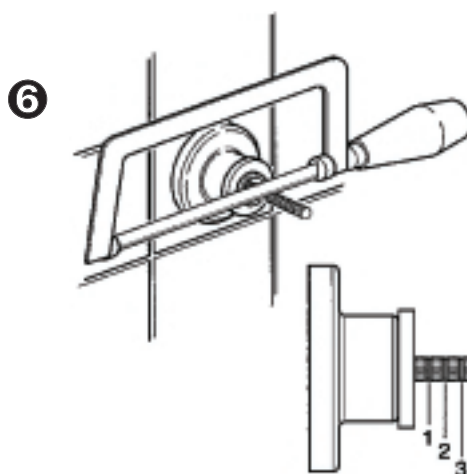
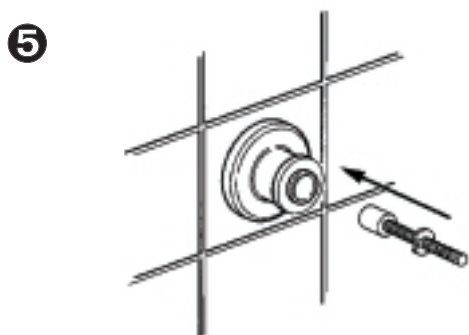
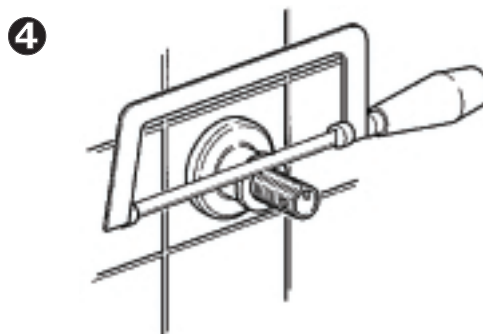
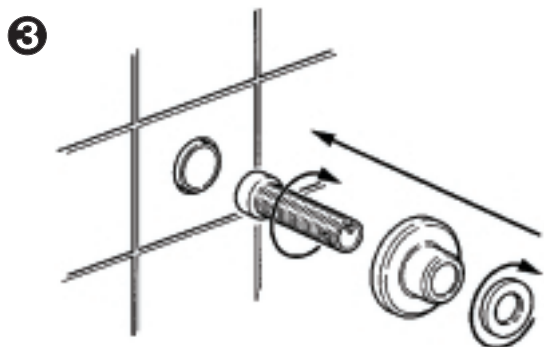
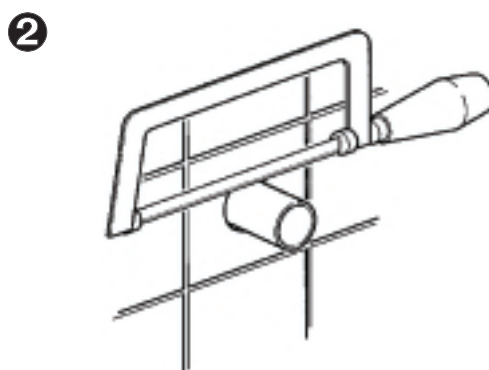
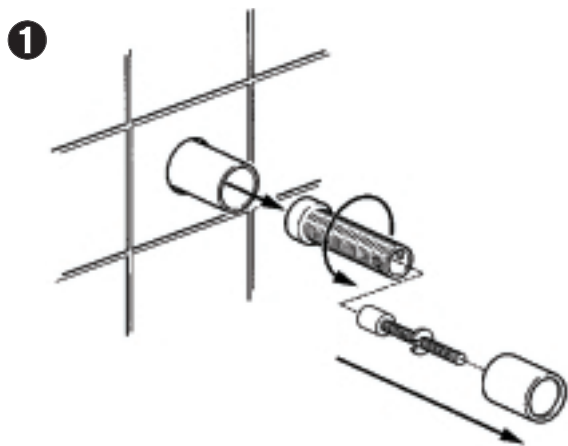

Conversion set
Kit de transformation
Kit de transformacion

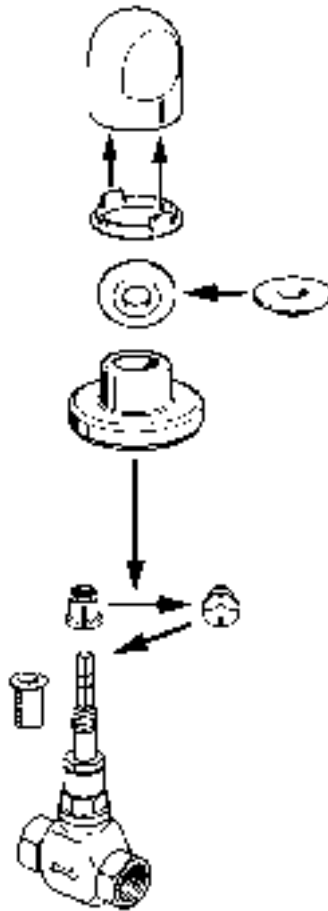

Installation dimensions
Dimensions d'encastrement
Dimensiones de instalación

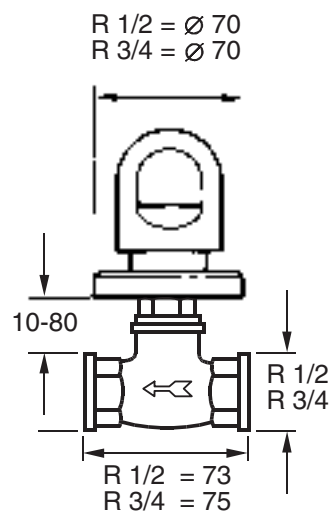

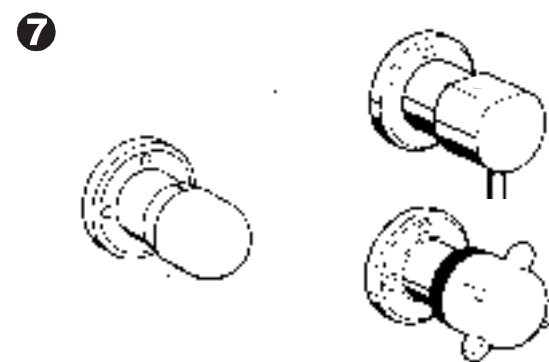
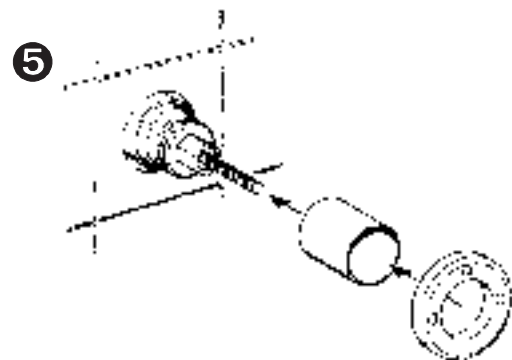
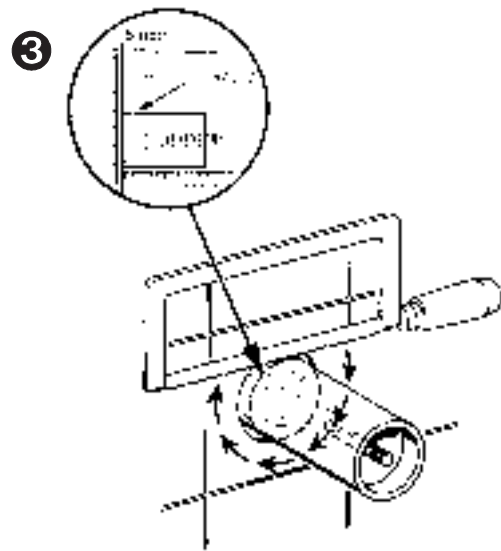
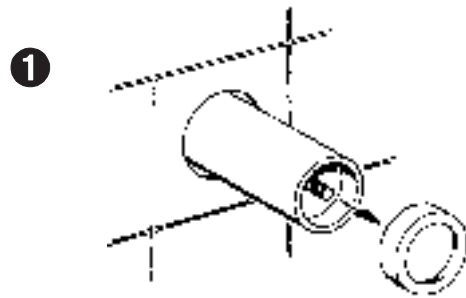
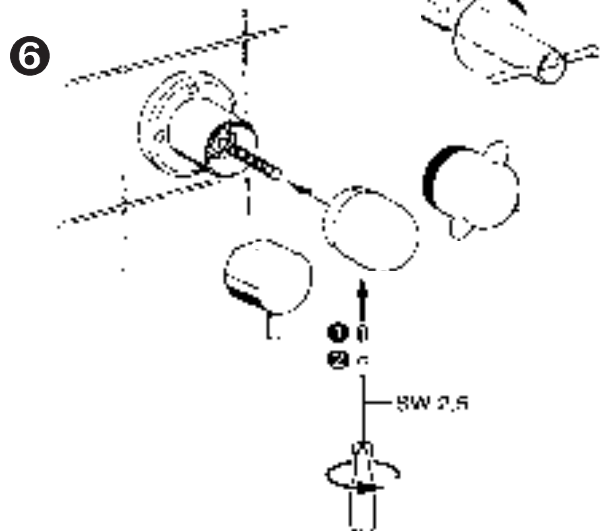
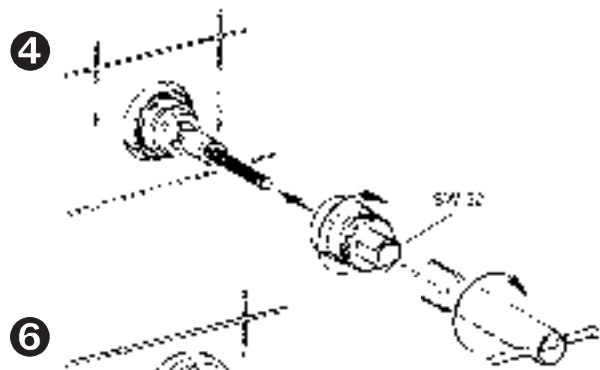
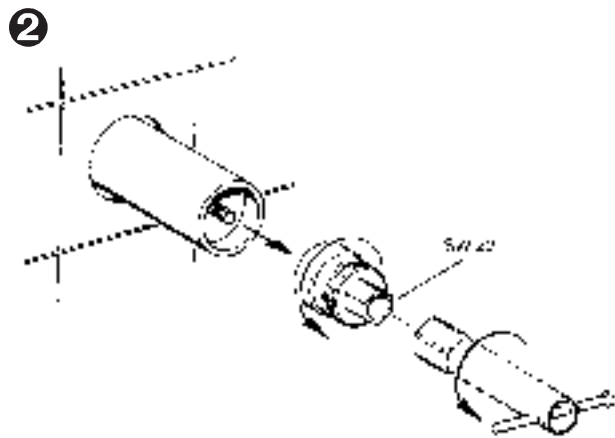

Conversion set
 Kit de transformation
 Kit de transformacion

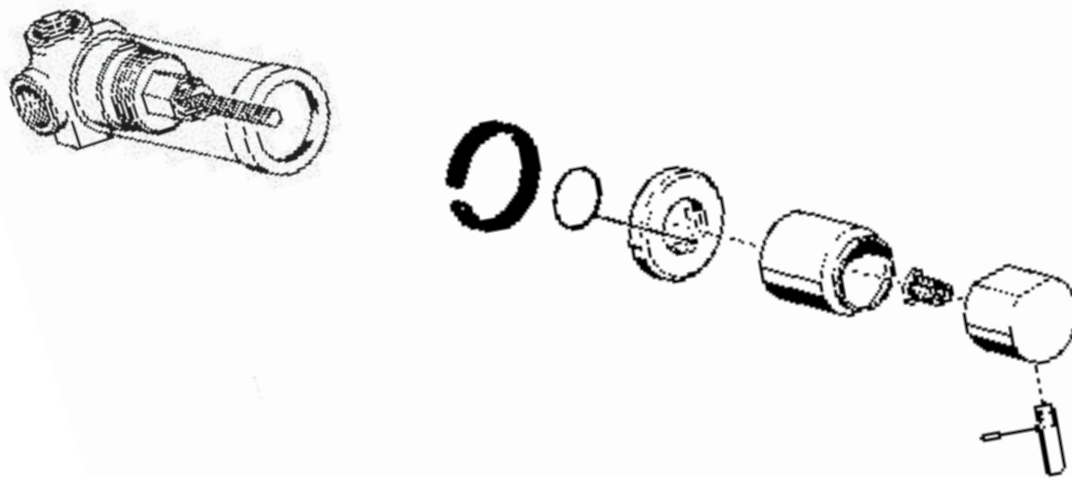

Installation dimensions
 Dimensions d'encastrement
 Dimensiones de instalación

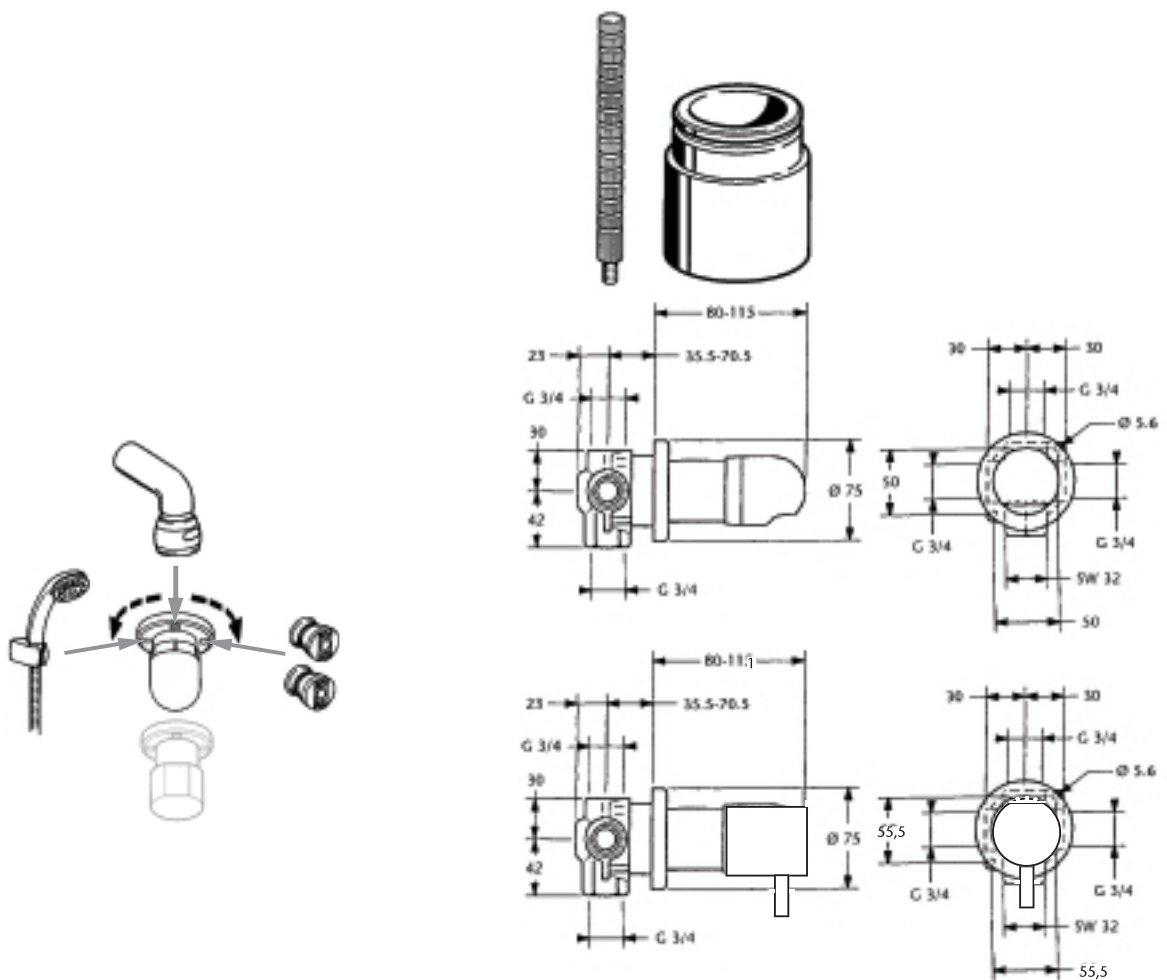

In General

- Faucet surface should be of room temperature before cleaning (elevated temperature increases destruction of the surface).
- Never use harsh or aggressive cleaning agents or detergents.

Maintenance

- Faucets should be dried with soft cloth daily.
- Never use corrosive cleaners or cleaning pads.

Cleaning

- Dirt or calcareous deposits on faucet's surface may be removed with soft detergent or with soapy water!
- Rinse will immediately with water (make sure no chemicals remains on surface)
- Dry with soft cloth

Instructions principales pour le nettoyage

- Durant le nettoyage, la surface du robinet doit être froide (la chaleur accélère l'usure de la surface)!
- Nous vous prions de faire attention aux indications mentionnées sur les nettoyages!
- Assurez vous que les produits ne contiennent pas d'acides ou des substances corrosive.

L'entretien

- Le robinet doit être nettoyé chaque jour avec un chiffon mou.
- Evitez absolument l'usage des brillants pour métaux, éponges abrasives ou produits similaires!

Le nettoyage

- Enlevez salissures et dépôts calcaires de la surface du robinet seulement avec des produits qui ne sont pas agressifs!
- Immédiatement après le nettoyage, rincer bien les résidus des détergents avec de l'eau froide!
- Sécher avec un chiffon mou.

Avisos básicos de limpieza:

- Cuando se procede a limpiar la grifería, su superficie debe estar fría (el calor acelera la destrucción de la superficie)!
- Respetar los avisos de limpieza del fabricante del detergente!

Cuidado:

- Secar la grifería frotando diariamente con un paño blando!
- Evite, imprescindiblemente, detergentes y esponjas de limpieza raspantes!

Limpieza:

- Quitar las manchas de suciedad o cal en la superficie de la grifería sólo con un detergente poco agresivo!
- Inmediatamente después de la limpieza eliminar, enjuagando con agua fría, todos los residuos del detergente!
- Secar frotando con un paño blando.



E Damages to the faucets as a results of incorrect handling are excluded from the manufacturers warranty!

F Ces dommages survenus en raison d'un traitement inadéquat, des signes d'usure/traitement inadéquat, naturels ou du grand utilisation, sont exclus de notre garantie!

SP Daños, debidos a un tratamiento inadecuado, son excluidos de la nuestra garantía!