

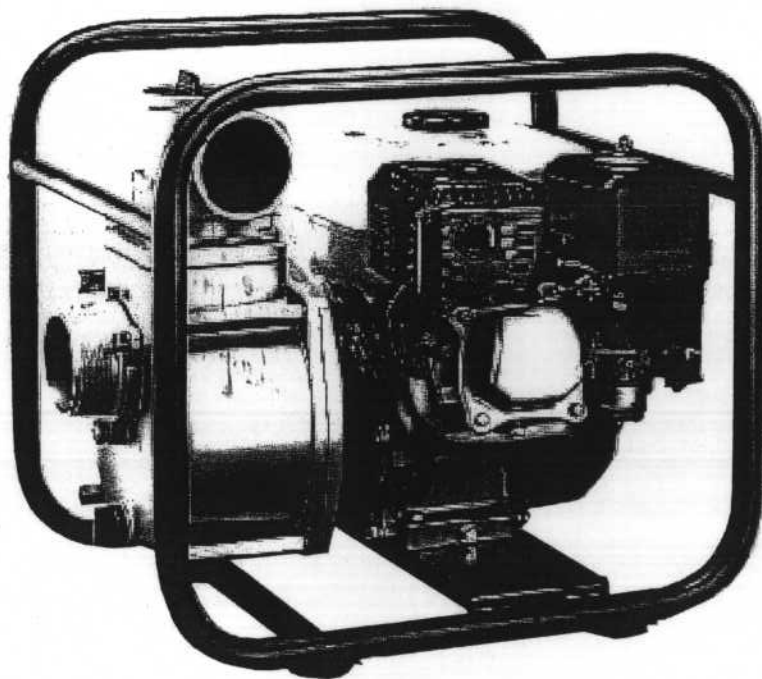

2" & 3" & 4"
SEMI-TRASH PUMPS
ITEM# S 109160, 109170, 109180

M109160A

OWNER'S MANUAL



*Any Questions, Comments or Problems
Call Customer Service 1-800-270-0810
Hours: Monday - Friday 7:00 AM to 5:30 PM
Saturday 7:30AM to 11:30AM*

THANK YOU

Thank you for purchasing a NorthStar Semi Trash Series water pump. Your machine is designed for long life, dependability, and the top performance you demand. Please take time now to read through this manual so you can better understand the machine's operation, maintenance and safety precautions. Everyone who operates this water pump must read and understand this manual. The time you take now will prolong your water pump's life and prepare you for its safe operation. Enjoy the exceptional performance of your Mustang Semi Trash Series water pump.

THIS PUMP CAN PASS UP TO 1/3" SOLIDS

ANSI SAFETY DEFINITIONS

DANGER indicates an imminently hazardous situation which, if not avoided, will result in death or serious injury. This signal word is to be limited to the most extreme situations.

WARNING indicates a potentially hazardous situation which, if not avoided, could result in death or serious injury.

CAUTION indicates a potentially hazardous situation, which if not avoided, may result in minor or moderate injury. It may also be used to alert against unsafe practices.

SAFETY PRECAUTIONS

1. Before starting the pumps, follow all of the instructions in this manual and any supplemental instructions supplied with the pump.
2. Any person operating this pump and its power unit should be fully aware of its safe operation before they start using it.
3. Never use these pumps for pumping flammable liquids such as diesel or gasoline.
4. Never operate an engine driven unit in an explosive atmosphere, near combustible materials, or where insufficient ventilation exist unless specific provisions have been made regarding the power unit so as to prevent possible injury and damage. Be certain the power unit is safe for the area in which it is to be operated.
5. Always be sure the unit is on a secure footing. Keep the immediate pump area free of all unauthorized personnel. If the pump is sitting beside a pit, be sure it is well anchored so that it does not fall in.
6. Never operate the unit with any guards removed.
7. Do not over tighten the drain or filler plugs. Excessive force may damage the threads or the pump body.
8. With engine driven pumps: A) Observe all safety precautions for the handling of fuel. B) Never refuel the engine while running. C) Never refuel a hot engine. D) Run engine only in well ventilated areas.
9. Before working on this pump make sure the power unit cannot inadvertently be started.
10. Be sure the power unit, pump, wiring and piping installations are suitable for the liquids being pumped and comply with all applicable codes and regulations.
11. Use at least 12" (300 MM.) of flexible hose to make plumbing connections to the pump body. Rigid piping may put stresses on the pump, causing damage. If rigid piping must be used, properly support it so as to eliminate stresses on the pump.
12. Do not run the pump dry. Always fill the pump body with water before starting. It is not necessary to drain the pump body after each use, unless there is danger of freezing, settling of solids, or crystallization.
13. Do not subject pump to extreme conditions of acidity or basicity. Consult factory for specific recommendations concerning chemicals and temperatures.
14. Only use original spare parts.

SET UP INSTRUCTIONS

1. A suction strainer should be attached to the suction hose or pipe. A suction strainer has holes or slots small enough to prevent large debris from working through and damaging the pump. Keep the strainer clean. If possible, suspend the strainer to keep it from working into sediment.
-Or-
A) Prepare a bed of large stones on which the strainer will rest.
B) Tie the strainer inside a basket or pail.
2. Fill the engine crankcase with oil as specified in the engine manual.
3. Fill the engine with fuel (see engine manual).
4. Fill the pump with water utilizing the priming port on the top of the pump. (The pump self primes only when it is first filled with priming water)

WARNING *this pump is designed to pump water only. Never use the pump to pump flammable liquids.*

5. All hoses and pipe connections must be airtight.
6. Place the pump in a location as near to the liquid surface as possible, this will ensure proper pump suction. NOTE: 26ft is the maximum height the pump can draw to.
7. All hoses must be kept as straight as possible, avoid sharp bends.

OPERATING INSTRUCTIONS

1. Starting Engine - See Engine Manual.
2. Priming-Using the port on the top of the pump, completely fill the pump chamber with water before starting the engine.

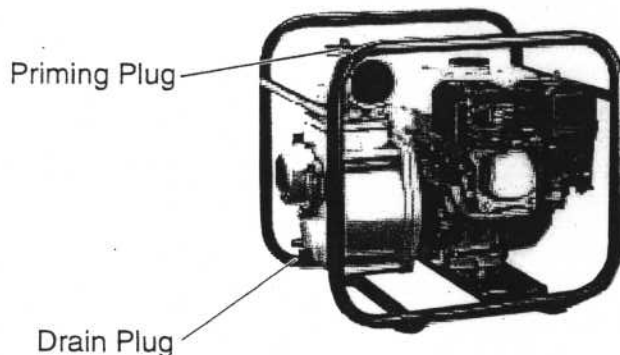

3. **Throttle Control** - When operating the pump when the pump is higher than the water surface, you may need to speed up the engine speed. When the pump is near the water surface, a slower engine speed can be used. This will save engine fuel and life.
4. **Check Valve** - If the discharge line runs vertical for more than 30ft. (9 meters), It is suggested to install a check valve near the discharge port of the pump. If this is done, it may be necessary to vent the top of the pump so that air can be expelled during automatic repriming. This air bleed may be accomplished by providing 1/4" (.5 cm) line from the top of the pump back to the liquid source. We will not assume any responsibility for damage to the pump if no check valve is used in the discharge line.
5. Never allow a vehicle to run over the flexible hose. This sudden shut off pressure can cause "hydraulic shock". If your flexible hose must be laid across a high traffic area, it is advised to protect it with planking.
6. Freezing water can be extremely dangerous to the pump, always drain the water from the pump if freezing temperatures are a factor.
7. Flushing out the pump at the end of each use is advised, some liquids being pumped may leave a solid or sticky residue. This may shorten the life of your pump.

TROUBLE SHOOTING

| PROBLEM | POSSIBLE CAUSES | CORRECTIVE ACTION |
|----------------------|---|---|
| Pump Doesn't Revolve | 1. Rusting inside engine. | Refer to instruction of engine manual. |
| | 2. Burned cylinders in engine | Refer to instruction of engine manual. |
| | 3. Rusting/Sticking of impeller. | Disassemble and clean. |
| Pump Fails To Prime | 1. Priming chamber not full enough. | Add more water to priming chamber. |
| | 2. Wrong Direction of rotation. | Change rotation direction. |
| | 3. Air leaks on suction line joints. | Check for loose screws or broken hoses. |
| | 4. Quick coupling gaskets worn. | Replace gaskets. |
| | 5. Loose or broken hose clamps. | Replace or tighten. |
| | 6. Priming chamber is over heated. | Pour cold water in chamber or let cool. |
| | 7. Engine speed is too slow. | Increase engine speed. |
| | 8. Worn or broken volute or impeller. | Replace when necessary. |
| | 9. Worn or broken mechanical seal. | Replace mechanical seal. |
| Low Capacity | 1. Clogged suction hose. | Clear obstruction. |
| | 2. Dirty strainer. | Clean strainer. |
| | 3. High friction losses due to hose kinks | Straighten suction and discharge hose. |
| | 4. Suction lift too high | Move pump closer to water surface. |
| | 5. Engine speed is too slow | Increase engine speed. |
| | 6. Worn or broken mechanical seal | Replace mechanical seal. |
| | 7. Drop of engine output | Repair engine. |
| | 8. Clogged Impeller. | Remove clog. |
| | 9. Worn Impeller | Replace Impeller |

PERFORMANCE SPECIFICATIONS

109160

| | |
|--------------------------|-----------------|
| SUCTION & DISCHARGE SIZE | 2" NPT |
| MAXIMUM SUCTION HEAD | 26 FT |
| MAXIMUM DISCHARGE HEAD | 98 FT |
| MAXIMUM PRESSURE | 43 PSI |
| MAXIMUM FLOW | 11376 GPH |
| PASSABLE SOLID SIZE | φ0.31" |
| MECHANICAL SEAL | SILICON CARBIDE |

PERFORMANCE CURVE

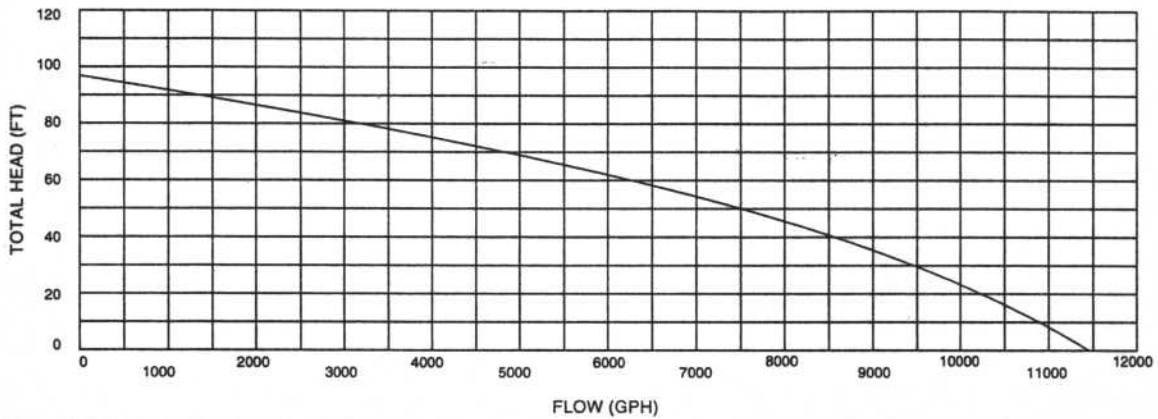

109170

| | |
|--------------------------|-----------------|
| SUCTION & DISCHARGE SIZE | 3" NPT |
| MAXIMUM SUCTION HEAD | 26 FT |
| MAXIMUM DISCHARGE HEAD | 85 FT |
| MAXIMUM PRESSURE | 37 PSI |
| MAXIMUM FLOW | 16200 GPH |
| PASSABLE SOLID SIZE | φ0.35" |
| MECHANICAL SEAL | SILICON CARBIDE |

PERFORMANCE CURVE

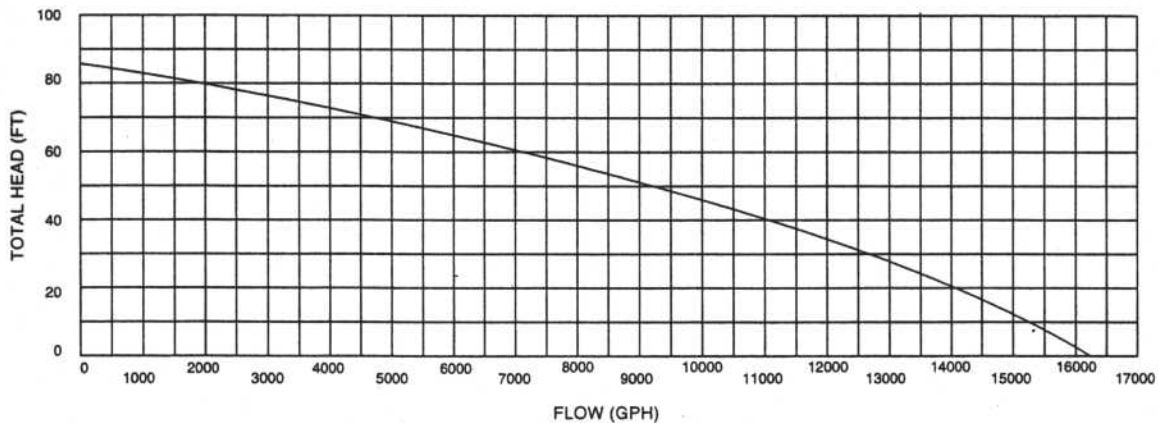

109160 / 109170 Parts Breakdown

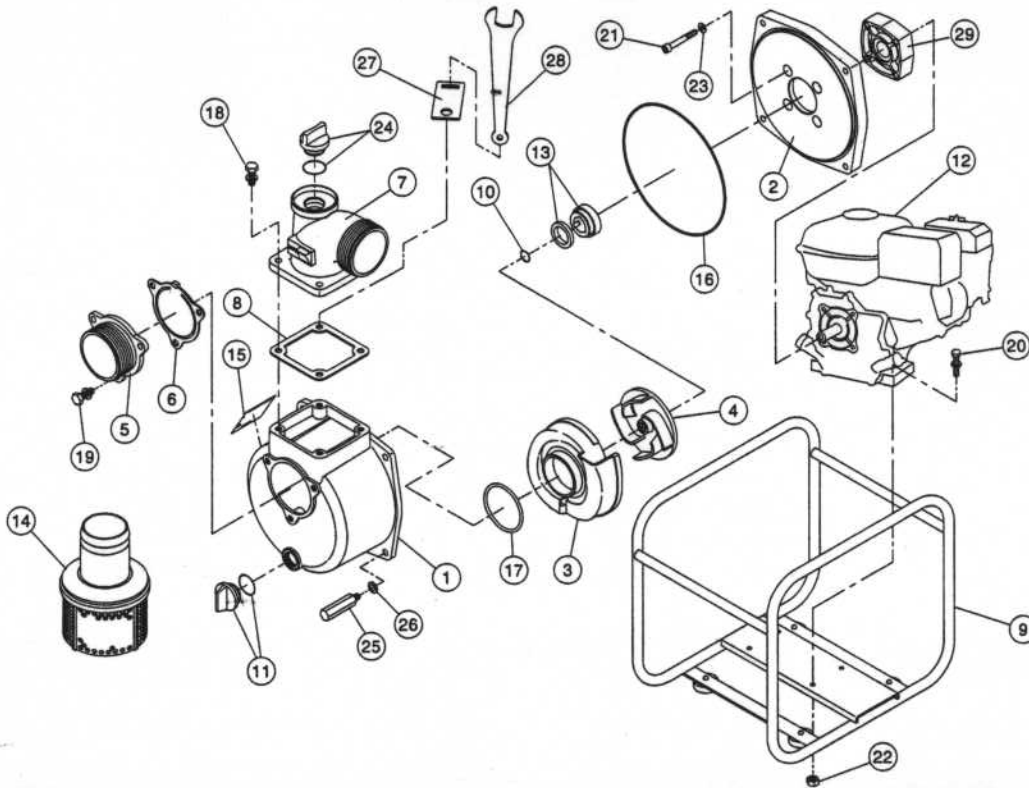

2" 109160

| ITEM | PARTS # | DESCRIPTION | QTY |
|------|-------------|-------------------|-----|
| 1 | KP0112578 | Pump casing | 1 |
| 2 | KP0114027 | Flange bracket | 1 |
| 3 | KP0115169 | Volute casing | 1 |
| 4 | KP0115168 | Impeller | 1 |
| 5 | KP0112822 | Suction flange | 1 |
| 6 | KP0112665 | Check valve | 1 |
| 7 | KP0115861 | Delivery flange | 1 |
| 8 | KP0110541 | Flange packing | 1 |
| 9 | KP0117548 | Base set | 1 |
| 10 | KP0110466 | Adjusting washer | 1 |
| 11 | KP0118078 | 20A Plug set | 1 |
| 12 | KP0114345 | Engine | 1 |
| 13 | KP0115159 | Mechanical seal | 3 |
| 14 | KP0118159 | Strainer | 1 |
| 15 | KP0116538 | Name plate | 1 |
| 16 | KP0115014 | O-ring 1517-42.5 | 1 |
| 17 | KP0112792 | O-ring P54 | 1 |
| 18 | KP743119047 | Bolt M8x25 | 4 |
| 19 | KP743119045 | Bolt M8x20 | 3 |
| 20 | KP743119051 | Bolt M8x35 | 4 |
| 21 | KP734532076 | Socket bolt M8x60 | 4 |
| 22 | KP827419008 | Nut M8 | 4 |
| 23 | KP854255008 | Seal washer | 4 |
| 24 | KP0118078 | 20A Plug set | 1 |
| 25 | KP0115115 | Long bolt M8 | 4 |
| 26 | KP843822008 | Washer ϕ 8 | 4 |
| 27 | KP0115230 | Wrench holder | 1 |
| 28 | KP0115185 | Spanner | 1 |

3" 109170

| ITEM | PARTS # | DESCRIPTION | QTY |
|------|-------------|-------------------|-----|
| 1 | KP0112795 | Pump casing | 1 |
| 2 | KP0115269 | Flange bracket | 1 |
| 3 | KP0115541 | Volute casing | 1 |
| 4 | KP0115539 | Impeller | 1 |
| 5 | KP0112876 | Suction flange | 1 |
| 6 | KP0112799 | Check valve | 1 |
| 7 | KP0113337 | Delivery flange | 1 |
| 8 | KP0110584 | Flange packing | 1 |
| 9 | KP0117434 | Base set | 1 |
| 10 | KP0110491 | Adjusting washer | 1 |
| 11 | KP0118078 | 20A Plug set | 1 |
| 12 | KP0114303 | Engine | 1 |
| 13 | KP0115159 | Mechanical seal | 3 |
| 14 | KP0118195 | Strainer | 1 |
| 15 | KP0120342 | Name plate | 1 |
| 16 | KP0115015 | O-ring 1517-46.5 | 1 |
| 17 | KP0113989 | O-ring P74 | 1 |
| 18 | KP743119063 | Bolt M10x30 | 4 |
| 19 | KP743119061 | Bolt M10x25 | 3 |
| 20 | KP743119053 | Bolt M8x40 | 4 |
| 21 | KP734532076 | Socket bolt M8x60 | 4 |
| 22 | KP827419008 | Nut M8 | 4 |
| 23 | KP854255008 | Seal washer | 4 |
| 24 | KP0118079 | 25A Plug set | 1 |
| 25 | KP0115542 | Long bolt M10 | 4 |
| 26 | KP843822010 | Washer ϕ 10 | 4 |
| 27 | KP0115588 | Wrench holder | 1 |
| 28 | KP0115589 | Spanner | 1 |
| 29 | KP0115540 | Spacer | 1 |