

Nokia Mediamaster
9828 T

Owner's Manual

NOKIA
CONNECTING PEOPLE

NOKIA

Declaration of Conformity

Manufacturer: Nokia Corporation through its unit
Nokia Home Communications

Address: Keilalahdentie 4,
FIN-02150 Espoo,
Finland

Declares that the product

Product: Mediamaster 9828 T

is in conformity with the following Directives and Standards

Directives: 73/23/EEC
93/68/EEC
89/336/EEC
92/31/EEC

Standards: EN 55013:1990 + A12 + A13 + A14
EN 55020: 1994 + A11 + A12 + A13 + A14
EN 60065: 1998

Linköping, 26th of September, 2001

Nokia Home Communications

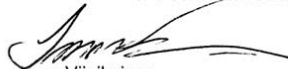

Ismo Viinikainen
Head of Product Creation

MEDIAMASTER 9828 T

Contents

General information	4	Application Download ("Open TV")	16
For your safety	4	Information. The "i" button	17
Remote control	5	Guide	17
Front and rear panel	6	List of Channels	18
About smartcard and CA module	7	Options. The green button	18
General	7	TV Release. The 0 button	19
Inserting the CA module and the smartcard	7	Video Recording	19
Connection	8	Teletext. The TEXT button	19
Preparing the Remote Control	8	EXIT TV	19
About the digital transmission	9	Main menu	20
Connecting to the TV aerial	9	General Information	20
Connecting the Mediamaster	10	TV and Radio Channels	20
Connecting the Mediamaster to the TV	10	Edit Channels	20
Connecting a TV and VCR	10	Guide	24
Connecting an Satellite Receiver and a VCR	11	System Configuration	24
Connecting a HiFi system	11	Channel Search	24
Switching on for the First Time with		TV Settings	25
SCART Connections	12	Time adjustment	25
Procedure when RF Connections are Used	12	Receiver Upgrade	26
First time installation	13	Reinstall	26
General Information	13	User Preferences	26
The Welcome Menu	13	Language Preferences	26
Language	13	Parental Control	27
RF modulator type	14	Appearance Preferences	27
Channel Search	14	System Information	28
Channel Search Progress	15	Conditional Access	28
Time adjustment	15	Glossary of terms	29
Finishing the first time installation	15	Problem solving	30
Viewing mode	16	Front panel display	31
General Information	16	Technical specifications	32
Programme Information	16		

Nokia and Nokia Connecting People are registered trademarks of Nokia Corporation. Other product and company names mentioned herein are trademarks or trade names of their owners.

Nokia operates a policy of continuous development. Therefore we reserve the right to make changes and improvements to any of the products described in this manual without any prior notice.

Copyright © 2001. Nokia Corporation.

All rights reserved.

GENERAL OPERATION OF THE MEDIAMASTER

Throughout this manual you will notice that the everyday operation of your Mediamaster is based on a series of user friendly on-screen displays and menus. These menus will help you get the most from your Mediamaster, guiding you through installation, channel selection, viewing and many other functions.

All functions can be carried out using the buttons on the remote control, and some of the functions can also be carried out using the buttons on the front panel.

If at any time when using the menus (except Installation and Reinstall) you want to return to the normal TV mode, press the **EXIT** button.











Should you experience any difficulties with the operation of your Mediamaster, please consult the relevant section of this manual, including the Problem Solving, or alternatively call your dealer or a customer service adviser.

FOR YOUR SAFETY

- For sufficient ventilation, there must be at least 10 cm free air space above, behind and on each side of the Mediamaster.
- Do not cover the Mediamaster's ventilation openings with items such as newspapers, tablecloths, curtains or similar.
- Do not place the Mediamaster on top of a unit that emits heat.
- Do not expose the Mediamaster to dripping or splashing liquids.
- Do not place any objects filled with liquids, such as vases, on the Mediamaster.
- Do not place naked flame sources, such as lighted candles, on the Mediamaster.
- Use a soft cloth and a mild solution of washing-up liquid to clean the casing.
- Do not connect or modify cables when the Mediamaster is plugged in.
- Do not remove the cover.
- Service should be carried out only at a Nokia Authorised Service Centre.
- Please note that the only way to isolate the Mediamaster completely from the mains supply is to unplug the mains lead!

REMOTE CONTROL

This section describes how to operate the Mediamaster using the buttons on the remote control. Some of the functions can also be carried out using the buttons on the front panel.

-  Switch the Mediamaster in and out of standby mode.
- EXIT TV** To return to the viewing mode from a menu without storing settings (in menu mode.)
-  Switch between TV or Radio mode (in viewing mode.)
-  Turn the sound off/on (mute.)
-  Adjust the volume. The Mediamaster's maximum level is controlled by the TV's present volume setting.
- 0-9** Change channel and to select individual menu options.
Note: If 0 is entered as the first digit, the TV Release functionality is activated (see below.)
- 0**  TV Release. Switch between digital TV, analogue TV and analogue satellite TV and VCR, when your systems are connected by SCART leads.
- i** Info. To display short and extended information (if transmitted) about current and next programmes.
- BACK** Go back one level in the menus.
- TEXT** Select teletext information.
Press to enter teletext (if available).
- MENU** To display or exit from the "Main Menu" screen.
- GUIDE** To obtain a list of present and following programmes for the available channels. This information is only shown if your Service Provider transmits programme information (EPG information.)
- P+ P-** Change channels up and down.
-  Change page in a menu/list/text if more than one page is available. To browse through teletext history.
-  Move up/down in the menus and to change channels.
-  Change settings in menus.
- OK** Confirm choices and selection of a highlighted item.
Display the TV channel list.
-  (Red) To download an "Open TV" application
- OPTION** (Green) Select options in viewing mode.
-  (Blue) Toggle between present and previous TV/Radio channels.
- FREEZE** (Yellow) Select the freeze function.
Press once to freeze the screen picture.
Press any other key to return to normal mode again.



FRONT AND REAR PANEL

Front Panel

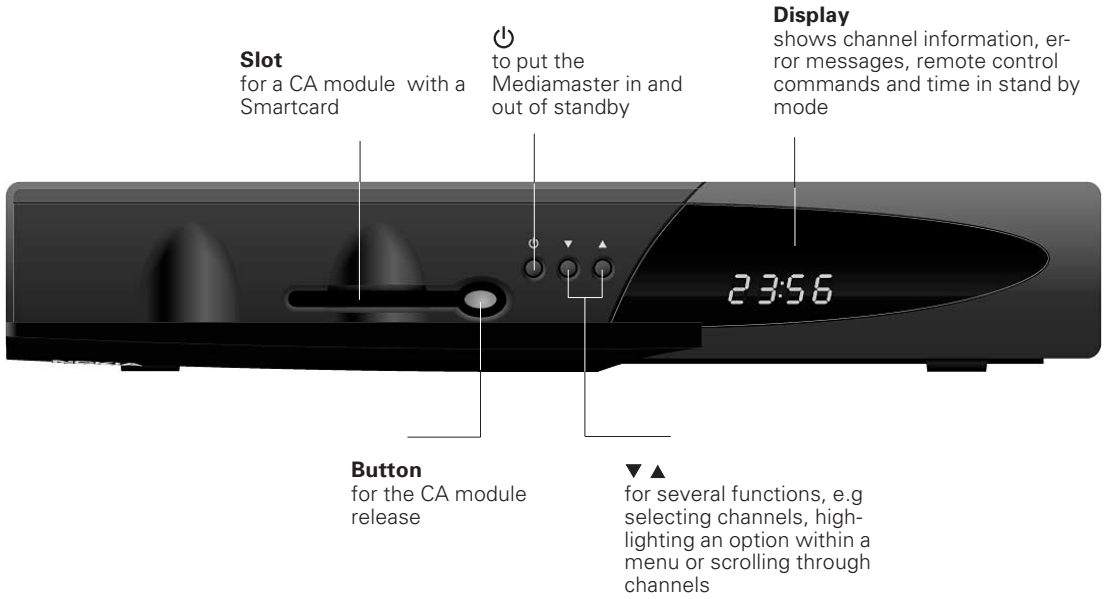

Rear Panel

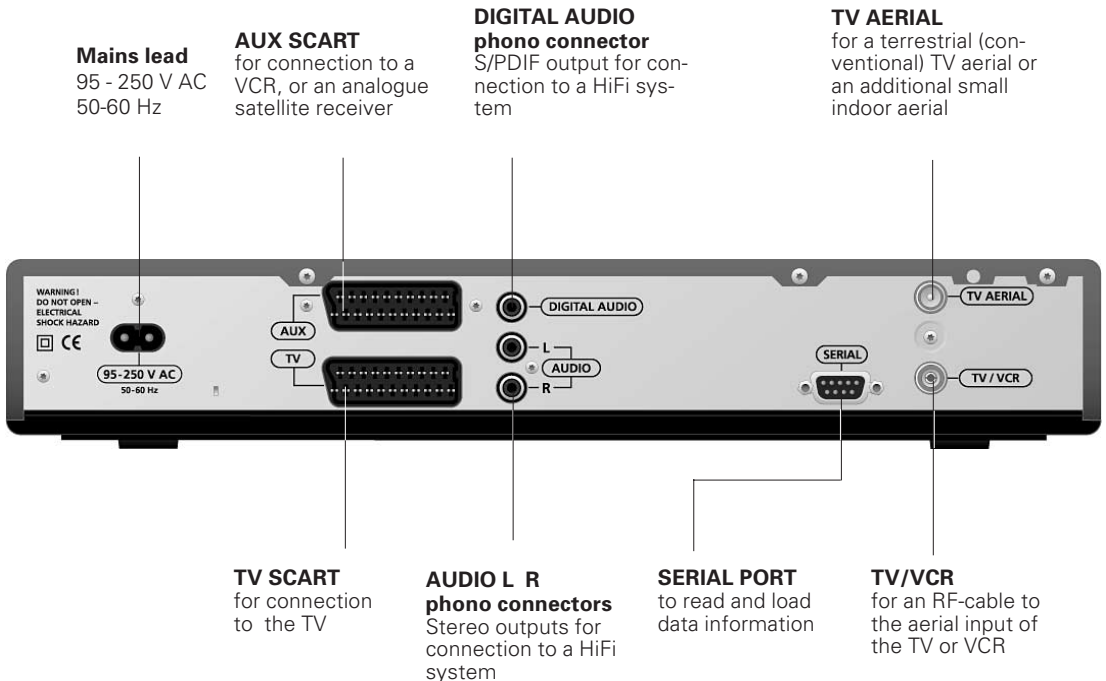

ABOUT THE SMARTCARD AND CA MODULE

General

To be able to receive terrestrial scrambled digital channels you will need a CA module and a Smartcard from a Service Provider.

There are a few different CA modules on the European market. Each one of the CA modules support a certain kind of encryption system. Examples of such a system are Viaccess, Conax, Irdeto, Nagravision and Mediaguard. Depending on in which country you use the Mediamaster, your local salesman will provide you with the right type of CA module.

Please note that a Smartcard may only be valid for a single Service Provider and due to this, a specific range of channels.

The Smartcard and the CA module may cause special menus not described in this manual. Follow the instructions from the Service Provider.

Note: The CA modules and Smartcards are only distributed by Service Providers and special distributors, not by Nokia.

After insertion, leave it in the slot permanently. Do not remove it again, unless you will be asked to do so. This is important, because if, for example, your Service Provider wants to download new information to the Smartcard, the card has to be in the slot.

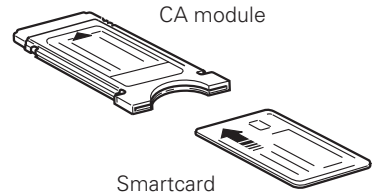

Inserting the CA module and the smartcard

Insert the CA module and the smartcard according to the instructions provided with the module.

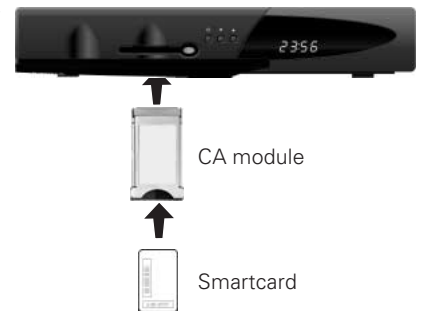

CONNECTION OF THE MEDIAMASTER

The box for your Mediamaster should contain the following items:

- the Mediamaster
- remote control with 2 AAA batteries
- SCART lead (fully featured 1,0 metre)
- aerial/RF lead (double screened 1,5 metres)
- Owner's Manual
- Software License agreement
- mains lead



About the SCART sockets

- The rear panel of the Mediamaster is equipped with 2 **SCART** sockets (see diagram). **When you connect other products to any of these sockets, always use fully featured SCART leads** (as supplied). There are "less well specified" SCART leads on the market and picture quality could be reduced if you use them.



SCART socket

Preparing the Remote Control

- Remove the cover on the battery compartment at the bottom of the remote control.
- Insert the 2 AAA (1,5 V) batteries, as shown in the diagram, taking care to observe the + and - markings indicated inside.
- Replace the cover.

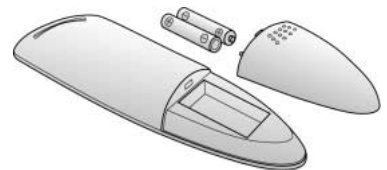

INSTALLATION OF THE MEDIAMASTER

About the digital transmission

Digital Radio and TV signals can be blocked by buildings, mountains and the terrain. Depending on if the receiver is located in a depression in the ground, behind a mountain or in a concrete building, the quality of reception may vary considerably.

A digital signal can be "boosted" if reflections of it (from e. g. a building) are added to the original signal.

Reflections can be used for reception by directing the aerial towards a mountain or a high building, providing that they do not block the transmitter.

As with most other transmissions, bad weather does affect the reception quality negatively.

Connecting to the TV aerial

You can connect the Mediamaster to the following type of aerials:

1. Standard outdoor aerial

Where possible, use an outdoor roof aerial intended for receiving UHF channels between 21 and 69.

Please note the following:

- In some block of flats, the roof-mounted aerial system includes a filter and channel selector. If so, the aerial will probably not work with the Mediamaster. Please consult the landlord.
- Many older roof-mounted aerials may only receive a limited number of channels. As a result, digital channels transmitted on higher frequencies are difficult or even impossible to receive. The problem can be solved by replacing the roof aerial.
- Some outdoor aerials are directed towards an analogue transmitter. The aerial must be directed towards a digital TV transmitter.
- It is not always advisable to position the aerial as high as possible. If problems arise, experiment with different aerial heights.

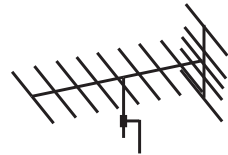

2. Indoor and window-mounted aerials

This type of aerial may be enough if the reception conditions are very good. If an indoor aerial is used, please note the following:

- Use an aerial for UHF channels 21 - 69, such as a directional aerial.
- Place the aerial by the window and directed towards the TV transmitter, if possible.
- An aerial with an amplifier is recommended as it may provide a stronger signal.
- The strength of the TV signal varies according to reflections from e. g. buildings. The signal penetrates thick stone or concrete walls poorly. However, a wooden building is not a big barrier to digital TV signals.

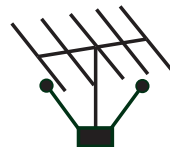

INSTALLATION OF THE MEDIAMASTER

Connecting the Mediamaster

There are many different types of TV/VCR and other equipment you can connect to the Mediamaster.

In this manual you will see some of the most common ways to connect your equipment.

If you use RF leads you will have to tune your TV and VCR to the Mediamaster output channel (see page 12).

If you have problems with your connections and need help, contact **your dealer or Service Provider**.

Connecting the Mediamaster to the TV

- Connect a SCART lead between the main SCART socket on the TV and the TV SCART socket on the Mediamaster.
- Connect an RF lead from the TV/VCR output on the Mediamaster to the RF input socket on the TV.
- Connect the TV aerial to the TV AERIAL input socket on the Mediamaster.

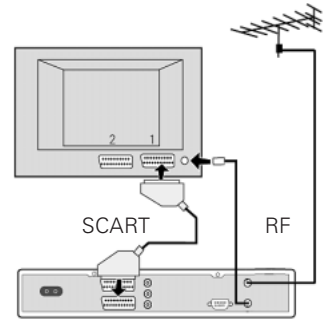

Connecting a TV and VCR

Refer to your VCR's manual for full instructions.

If your TV and VCR have two SCART-sockets

- Connect a SCART lead between the main SCART socket on the TV and the TV SCART socket on the Mediamaster.
- Connect a SCART lead between the VCR and the AUX SCART socket on the Mediamaster.
- Connect a SCART lead between the VCR and the second SCART socket on the TV.
- Connect an RF lead from the TV/VCR output on the Mediamaster to the RF input socket on the VCR.
- Connect an RF lead from the RF output on the VCR to the TV AERIAL input socket on the TV.
- Connect the TV aerial directly to the TV AERIAL input socket on the Mediamaster.

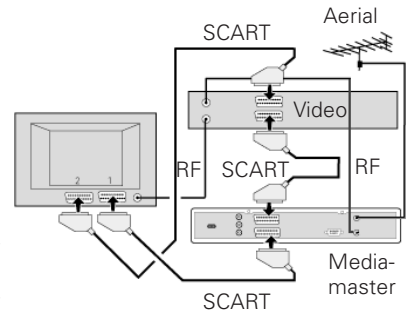

If your VCR only has one SCART-socket

- Follow connection details from above, but without the 3rd SCART lead. Your VCR will then need to be tuned to the Mediamaster.

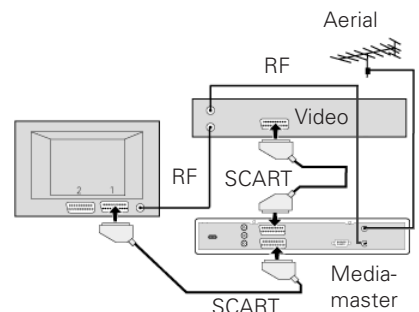

INSTALLATION OF THE MEDIAMASTER

Connecting an Satellite Receiver and a VCR

- Connect a SCART lead between the main SCART socket on the TV and the TV SCART socket on the Mediamaster.
- Connect a SCART lead between the TV SCART socket on the satellite receiver and the AUX SCART socket on the Mediamaster.
- Connect a SCART lead between the VCR and the 2:nd SCART socket on the TV (if available).
- Connect an RF lead from the RF output on the VCR to the TV aerial input on the TV.
- Connect an RF lead from the RF output on the satellite receiver to the RF input socket on the VCR.
- Connect an RF lead from the TV/VCR output on the Mediamaster to the RF input socket on the satellite receiver.
- Connect the TV aerial to the TV AERIAL input socket on the Mediamaster.
- Connect the coaxial cable between the LNB and the LNB socket **on the satellite (analogue or digital) receiver**.

Both the VCR and the analogue satellite receiver must be tuned to different UHF channels than the Mediamaster when using RF-connectors.

The analogue satellite receiver must be switched to OFF (standby) when you want to watch digital terrestrial channels from the Mediamaster.

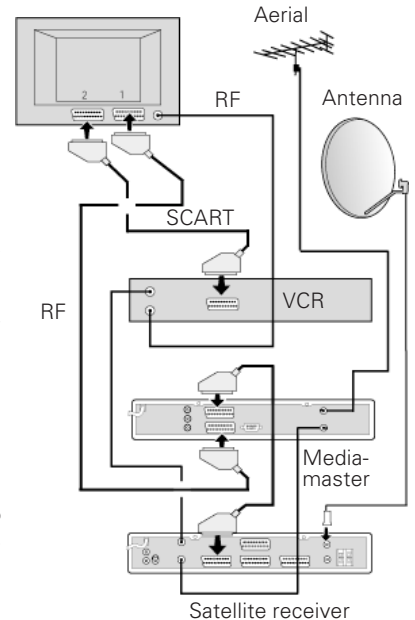

Connecting a HiFi system

- Connect an RCA/Cinch stereo cable from the AUDIO L R sockets on the Mediamaster to the LINE, AUX, SPARE or EXTRA input sockets on your HiFi system.
- If available you can connect an RCA/Cinch single cable from the DIGITAL AUDIO socket on the Mediamaster to your HiFi or Dolby Pro Logic system.

Note: To avoid interference you **must** use a screened audio cable.

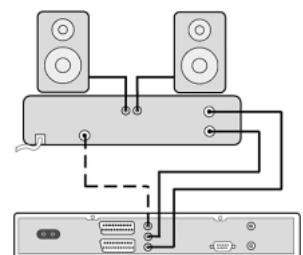

INSTALLATION OF THE MEDIAMASTER

Switching on for the First Time with SCART Connections

- Plug in your Mediamaster
- Now you will see the "Welcome" menu on the screen.
- Press **OK** on the Mediamaster remote control to start the Installation procedure.

You may now proceed to "First Time Installation."



Procedure when RF Connections are Used

This procedure is necessary only if your Mediamaster is connected to the TV with an RF lead and no SCART leads are used.

To tune your TV to the RF signal you might also need your TV manual in addition to this manual. The steps below explain what to do if you have been unable to use SCART leads in your connection.

- Plug in your Mediamaster.

Tuning your TV to the Mediamaster

- Select a channel number on the TV that is not currently used for other TV channels.
- Follow the instructions in your TV manual to tune the TV channel selector to UHF channel 43 (this is the Mediamaster's factory preset UHF channel). If you are already using this channel, select another non occupied UHF channel between 21 to 69 on the TV.
- If you need to change UHF channel you do as follows: First you change on the Mediamaster. Use the ▼ or ▲ buttons on the front panel of the Mediamaster, or on the remote. You will see the UHF channel number displayed on the front panel of the Mediamaster. Then, tune the TV channel selector to the same UHF channel.
- When you have correctly changed the UHF channel number you will see the "Welcome" menu on the TV screen. If there is interference from other channels you will have to change the chosen UHF channel.
- Follow the instructions in your TV manual to store this UHF channel as the channel used by your Mediamaster. You will have to select it when you want to watch terrestrial digital TV channels.
- Once the welcome message is visible, press the **OK** button on the Mediamasters remote control to start the installation procedure.

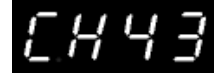

If for some reason you have to change the RF channel later, you can do this by using TV settings menu further on in this manual. If you have a VCR connected it must be tuned to a different UHF channel (between 21 to 69) than the Mediamaster.

You may now proceed to "First Time Installation."

FIRST TIME INSTALLATION

General Information

Once you have correctly connected the Mediamaster, you also have to perform a "First Time Installation."

During this procedure, helpful information is displayed at the bottom of the menus.

Please note!

The **OK** button always **confirms** a selection within these menus, and pressing it will take you to the next step in the installation process. However, and this is important, often more than one value has to be entered in a menu. First, perform all necessary settings on the different lines. Then, confirm them all simultaneously by pressing **OK**.

You can always go back to the previous menu by pressing the **BACK** button.

Use the **▲ ▼** buttons to move upwards and downwards from one line to another. Use **◀ ▶** to change settings.

You can also use the numeric buttons on the remote control to select a line in a menu and to enter numeric values.

The Welcome Menu

This picture indicates that you have started the installation procedure.

- Press **OK** on the remote control to start the Installation procedure.



Language

Select the desired menu language.

This will also be the main language for audio and subtitling.



FIRST TIME INSTALLATION

RF modulator type

If the Mediamaster is connected to the TV with a RF cable, you must select the right RF modulator alternative, which is dependent on the country where the Mediamaster is being used.

Select **Normal (PAL B/G)** for all countries except the UK.

Select **UK (PAL I)** when the box is used in the UK.

If you get picture but no sound, the RF modulator selection might be wrong.

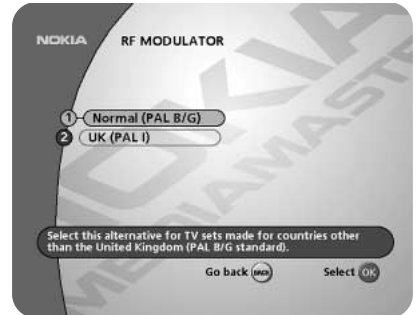

Channel Search

The Channel Search procedure can be performed in two different ways: **Automatic Search** or **Manual Search**.

Automatic Search *

- Start the Automatic search on by pressing **OK**.

Manual Search *

When you perform a Manual search you first need to enter some parameters for the channel search to work.

The information you need to enter in this menu is available from your Service Provider.

Frequency: Enter the frequency . If you enter the wrong figure(s), erase with the ◀ button.

Transmission Mode: Select 2k or 8k.

Guard Interval: Select one of the available alternatives.

Network Search: Select **Yes** if you want to search on all frequencies in a specific network.

- Press **OK** to start searching for channels. (See Channel Search Progress” on the next page.)

* Frequency Offset

Select **No** and only the standard, fixed, channel frequencies will be used at the search procedure. Under normal circumstances this will be quite sufficient. Select **Yes** when you want the search procedure to be more accurate. The fixed channel frequency will still be searched, but this time with two extra steps; ± 167 kHz from the fixed frequency. **NOTE!** You have to select Yes or No **before** you start the search procedure.

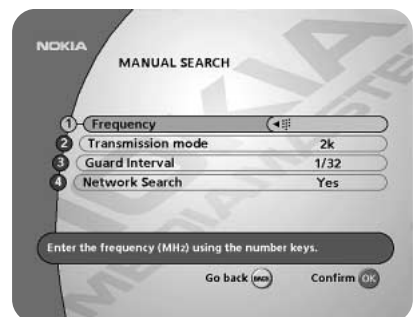
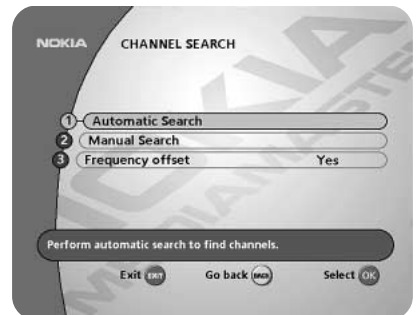

FIRST TIME INSTALLATION

Channel Search Progress

This menu will be shown as long as the Mediamaster is searching for channels to download

All channels found will be listed in two columns on the screen; TV channels in one column and Radio channels in the other.

Please note that the search procedure may take a few minutes.

When the search procedure has ended, the screen will show how many TV and Radio channels have been found.

Press **OK**.

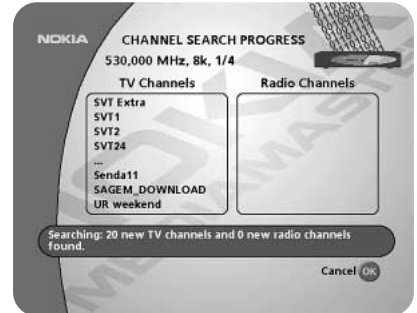

Time adjustment

The time is adjusted by using the ▼ ▲ buttons, ±1/2 an hour at a time.

You can also adjust the minutes by using the ◀ ▶ buttons.

Press **OK** to finish the first time installation, see below.

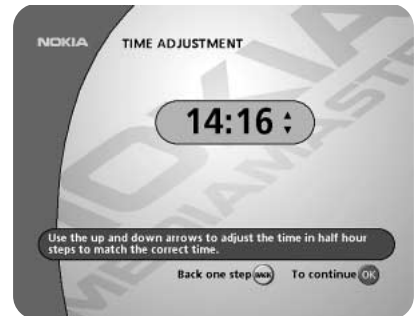

Finishing the first time installation

The channels found at the search procedure will now be saved. A message telling that the installation procedure is completed will be shown on the screen.

Press **OK** in order to start watching channels from the box.



VIEWING MODE

General Information

The following describes the basic functions of your Mediamaster while watching terrestrial digital TV .

Some of the functions described here are dependent on the Service Provider and can only be used if they are included in the transmitted programme information.

Please note, that during the Channel Search procedure, the Mediamaster may download a large number of channels. This may include channels from various Service Providers, also those to which you do not have access unless you have a Smartcard from one of those Service Providers.

If you select a programme to which you do not have access, you will get a message on the screen. This message may vary, depending on Service Provider and used Smartcard/CA Module.

While viewing, the current channel number will be shown on the front panel display.

In addition to the normal functions like switching the Mediamaster in/out of standby, changing the volume etc. there are some other useful functions which will be explained in this part of the manual.

You can always leave a menu at any time you want, without affecting any settings, by pressing the **EXIT** button.

Programme Information

Every time you change channels you will receive programme information for a few seconds.

The information may include:

Current time.

Channel list.

Channel number and name.

Name of the current and next programme.

The start and total time of the current programme.

A bar, indicating the elapsed time of the current programme.

Recommended lowest age limit for watching the programme.

The start and total time of the next programme.

Programme information will only be available if it is included in the transmission. Otherwise a "No information available" message will be shown.

You may change channel lists with the ◀▶ buttons.

Application Download ("Open TV" applications)

From some channels it is possible to download specific programme applications such as games and various information. Channels which provide these services will show a symbol in the upper left corner of the screen. By pressing the red button on the remote control you start the download of the application.

To close an application and return to watch TV, press the **P+** or **P-** button on the remote control.

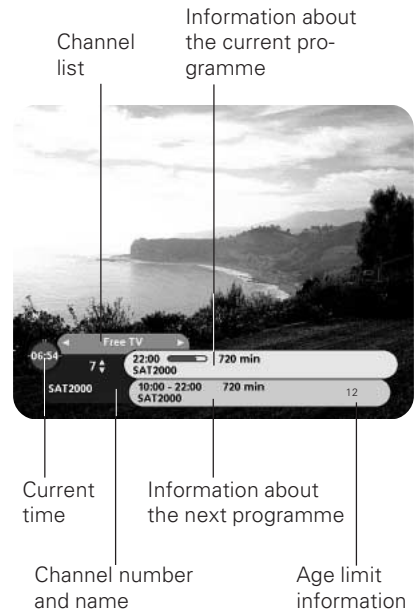

Press the red button on the remote control to start downloading an Open TV application

VIEWING MODE

Information. The “i” Button

The Mediamaster has the ability to display information about programmes currently being broadcast as well as those being broadcast next.

By pressing the “i” button while watching TV you will get a special Programme Information Banner. Select channel with ▼ ▲ or the numeric buttons.

The “i” symbol is coloured blue when displaying information about the current channel, and red when information for another channel is shown.



- Press “i” again to get more information about the current programme.
- If a lot of information is available you can use the double arrow button to see the rest of the text.
- Press “i” a third time to return to TV mode.

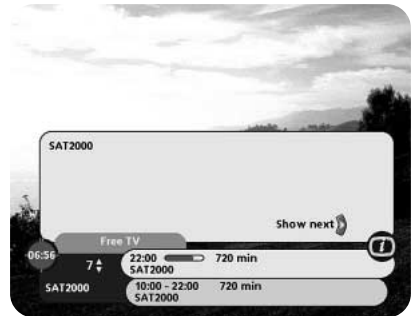

- In this view, you can select to get information about the current and next programme by using the ◀ ▶ buttons.
- You can leave the menus at any time and return to viewing TV by pressing **EXIT**.

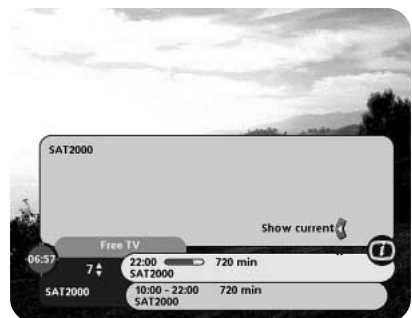

Guide

Press **MENU** Select **GUIDE**. Press **OK** and you get access to the **Nokia EPG** (Electronic Programme Guide) which will give the titles of the current and next programmes on different channels.

Use the ▼ ▲ buttons to move the cursor to another programme. Use the ◀ ▶ buttons to get information about next programmes. Use the double arrow buttons to move a page at a time up and down.

When a line is highlighted, you can get more information about this programme by pressing the “i” button.

In certain circumstances you may get an EPG from your Service provider instead. If so, please follow the instructions given in that menu.



VIEWING MODE

List of Channels

At the channel search procedure, 2 Channel lists named "TV channels" and "Radio channels" are created. A Radio list will only be created and highlighted when radio channels were available to download.

In the Channel lists scrambled channels are marked with a picture of a Smartcard (if this information is transmitted in the signal).

If you have performed a new SVT channel search the new channels found will be marked with a star in the "Channels" list.

Locked channels will be marked with a padlock.

While viewing TV or listening to a radio channel you get access to the respectively Channel list by pressing **OK**. The lists can also be selected in the main menu.

At the top of the menu you will see the name of the list. The current list is the one in which the channel you are watching right now is located.

- If the list contains a large number of channels, you can close networks to reduce the number of channels. You open/close a network by marking it and pressing . A closed network is indicated with .
- Change channel lists with .
- You can change channel by stepping with the buttons or enter the channel number with the numeric buttons on the remote control.
- To change one channel list page at a time, use the **double arrow** buttons.
- Press **OK** when a channel name is highlighted to start watching to it.
- You can also get more information about a marked (highlighted) channel by pressing the **"i"** button.

Name of the Channel list Indicates a closed network

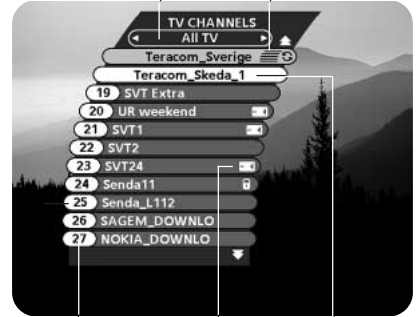

Channel number and name

Network name

Indicates a scrambled channel

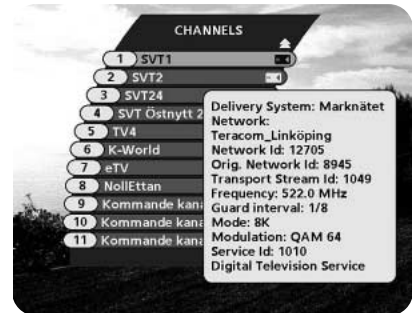

Options. The green button

By pressing the **OPTION** button, you open a menu in which it is possible to enter **temporary** settings. A menu will only appear if the programme contains any options to set or change. Settings made in this "options menu" are only valid for the programme you currently are watching. If you leave the programme and return to it again, the temporary settings will be gone.

Audio Language

Select among the different languages being broadcast.

Subtitle Language

Select among different subtitle languages. If you select **OFF**, you will not get any subtitling at all.



VIEWING MODE

Format

If you have a TV set with a 4:3 picture format, and the transmission is in 16:9, you can select Fullscreen or Letterbox to change display format.

Fullscreen will fill up the screen vertically, but cut off some information from the left and right sides of the picture.

Letterbox will give a complete picture, but leave black areas at the top and bottom.

TV Release (0)

With the **0** button you can toggle between:

digital terrestrial TV

analogue terrestrial TV

video (the video must be switched on)

(This is only valid if the units are connected via SCART cables, and not by a RF connection.)



Channel number

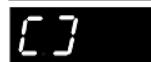

Analogue TV mode



Video mode. (The Video must be switched ON)

Video Recording

Please note, that during the recording of a programme, **everything** shown on the screen will be registered! For example, if you call up a menu from the Mediamaster on the screen, the menu will be recorded!

The TEXT Button (Teletext)

- Pressing the **TEXT** button will open a Teletext page (if Teletext is transmitted.) Select teletext pages with the numeric buttons on the remote control.
- You can also quickly step to the different page alternatives shown in any page by pressing ◀ ▶.
- Press **OK** on a selected number to go to that page.
- Press **EXIT, BACK** or **TEXT** to return to TV mode.
- The **0** button will show the index page (normally page 100.)
▲ ▼ will show the next or previous teletext page.
- You can use the **double arrow** buttons to browse through the pages you just have visited.

On most new TV sets you can use the TV's remote control to open and control the teletext functions while watching digital TV channels. (The function is called VBI insertion.) **NOTE:** Also see "Subtitles" settings on pages 26 and 27.



EXIT TV 🎵

This button has double functions.

While watching TV: The **TV/🎵** function is used to switch from TV to radio mode and vice versa.

When you have entered a menu, the **EXIT** function is used to leave the menu at any time without changing anything.

MAIN MENU

General Information

Many of the functions of the Mediamaster are available from the Main Menu.

- Press **MENU** to open it.



TV and Radio Channels

Please refer to “List of channels” on page 18.

Edit Channels

From these menus you can create and edit channel lists. You can, among other things, create favourite lists; add, delete, rename and arrange the order of the channels within the lists.

In the **All TV** list the channels are normally presented network by network. First the name of the network. Then the name of the regional network transmitter from which you are receiving the channels.

The **All TV** list can contain a lot of channels. By creating your own favourite lists you can make channel handling a bit more convenient.



MAIN MENU

Create list

Create your own favourite lists, containing the channels you watch most frequently. You can give each list a specific name, e.g. "Sport" or "Films."

How to give a specific name

This procedure is the same whether you enter a name for the first time or change an existing.

- Move to a new character position by using ►.
- To delete the last character use ◀.
- Enter the characters one by one (A...Z, 0...9) by using ▼ ▲. To speed up the procedure a bit you can use the double arrow buttons to jump 3 letters at the time.
- Figures can also be entered with the numeric buttons on the remote control.
- The next letter will be shown above the current, and the previous below it.
- Toggle between capital and lowercase letters with the **blue button**.

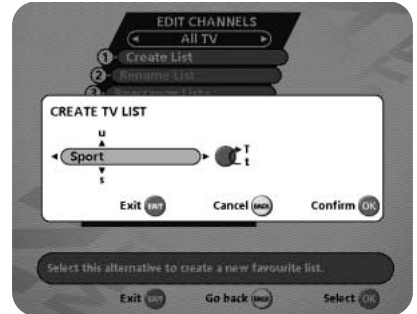

When you have given the list a name; press **OK** and you will enter the "Select Channels" menu (see next page) from where you add channels to the list.

Rename list

From here you can give an existing list a new name. Use the arrow buttons the same way as when you created the list.

Rearrange lists

If you have created several Favourite lists you can determine the sequence in which the lists will appear.

Delete list

If you want to delete a Favourite list completely, select the list and press **OK**.

MAIN MENU



Select Channels

From this menu you add and remove the channels in your Favourite Lists. You use the "All TV" list as base to select the channels from.

A channel is added or removed by pressing the **OK** button. The square to the right on a line will be empty for removed channels, and will contain an "x" for added channels.

- If you have a Favourite list that contains several networks, you can close the one(s) you are not going to work with. You open/close a network by first marking it and then pressing .

A closed network is indicated with  on the line.

- Move to desired channel(s) with  , double arrows or the numeric buttons, and add/remove them by pressing **OK**.
- When you are ready, confirm the selections and leave the menu by pressing **BACK** or **EXIT**.



Lock Channels

To get to this menu you first have to enter your access code. From here you can lock (and later unlock) channels in any of the lists in order to prevent e.g. your children from watching.

Select the channel you want to lock and press **OK**. Repeat the procedure for each channel you want to lock. When you lock a channel in any list, the channel will automatically be locked in all other lists.

A locked channel will be marked with a padlock symbol.



When watching TV, you will be asked to enter your access code before you can watch a locked channel.

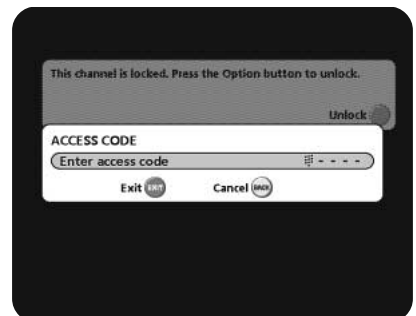

Rename Channels

Within any of your favourite lists you can rename the channels. Mark the channel you want to rename and press **OK**. The Rename dialogue box will then appear and let you modify the existing name.

To enter the new name, please follow the instructions under the headline **How to give a specific name** on page 21.

When you have changed a channel name, the new name will appear in all lists where the channel is included.



MAIN MENU

Rearrange Channels

From here you can arrange the sequence for the channels within your favourite lists.

- With ►, mark the channel you want to move to a new position within the list.
- Press ► again and the right side of the marked channel will change to ▼▲.
- Move the channel to the desired position with ▼▲ and press **OK**.

It is also possible to first mark several channels, and then move them all simultaneously.

- For each channel, press the ► button to add it to the set of marked channels.
- When a number of channels are marked this way and you want to move the whole set of channels, press ► again.
- The marked channels will now be put together into one group.
- The right side of the first and last marked channel will change to ▲▼ arrows respectively.
- Use the corresponding buttons to move the selected channels to a new position within the list.
- When the channels are in the position you want, press **OK**.

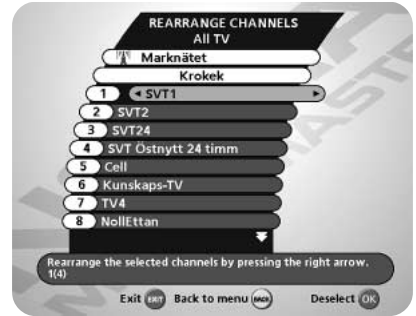

Delete Channels

From here, when the **All TV list** is selected in the “Edit Channels” menu, you can delete channels.

Please note. Channels deleted this way will be permanently deleted. The only way to get them back is to perform a new channel search.

To delete channels:

Mark the channel you want to delete and press **OK**. You will be asked if you really want to delete it. If so, confirm by pressing **OK** once more. If not, press **BACK**.

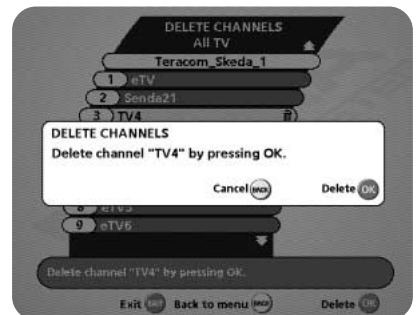

Remove Channels

From here, when a **favourite list** is selected in the “Edit Channels” menu, you can remove channels from those lists.

Mark the channel you want to remove and press **OK**. You will be asked if you really want to remove it. If so, confirm by pressing **OK** once more. If not, press **BACK**.

Channels removed from a list this way are **not** permanently deleted. They are still available from the **All TV** list.



MAIN MENU

Guide

Press **GUIDE** to get access to the receiver's EPG.
Refer to page 17.

System Configuration

You will be asked to enter your access code before you can open this menu. The code is preset to 1234 from the factory. (The code can be changed from the Parental Control menu. Refer to page 26.)

If you want to customize the system to suit you better, you can specify some settings from the submenus in the "System Configuration" menu.

Please note that many of these functions are the same as in the "First Time Installation."

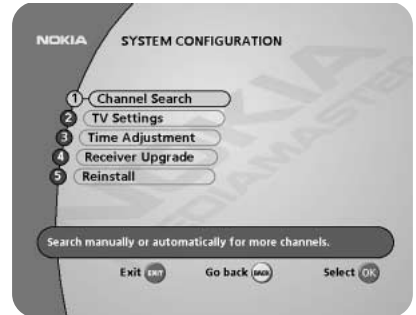

Channel Search

The Channel Search procedure can be performed in different ways. You can perform an Automatic or a Manual Search.
Refer to page 14.

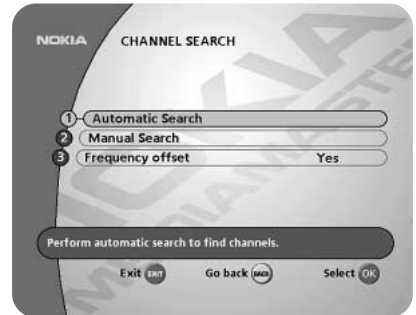

MAIN MENU

TV Settings

From here you can adjust settings concerning your TV.

TV screen format

Select your TV screen format.

The 4:3 format is the standard format for most TV screens. Select 16:9 for a wide screen TV.

TV signal

If the teletext function does not work when watching channels from an analogue satellite receiver connected to the Mediamaster, change this setting from RGB to PAL.

RF channel

Select this alternative if you have to change the RF channel. If you change the RF channel number in the Mediamaster, you must also change it to the same value on the TV. If you do not, the picture will become black.

Always test the receiver and any units connected to it before changing the RF channel. Never use an RF channel number that is close to a transmitting channel (\pm one channel number) or that is used by any of the connected units.

RF modulator type

If the Mediamaster is connected to the TV by an RF lead, you can select the RF modulator type. The RF Modulator affects a channel's audio. If you get picture but no sound, the RF modulator selection might be wrong.

Select **UK (PAL I)** if the Mediamaster is used in the UK.

Select **Normal** if it is used elsewhere.

Position of the RGB output

Adjust the horizontal position of the TV picture with the ◀ ▶ buttons. (The **TV signal**, see above, must be set to RGB for this function to work.)

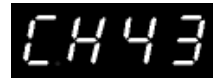
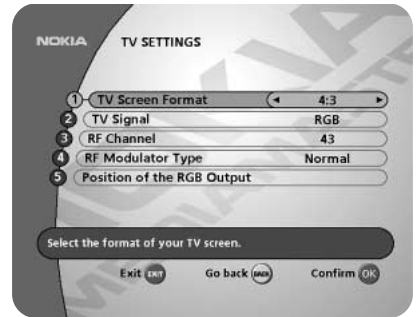

The RF channel number will be indicated on the front display of the Mediamaster.

Time adjustment

The time is adjusted by using the ▼ ▲ buttons, $\pm 1/2$ an hour at a time.

You can also adjust the minutes by using the ◀ ▶ buttons.

Press **OK** to finish the first time installation, see below.

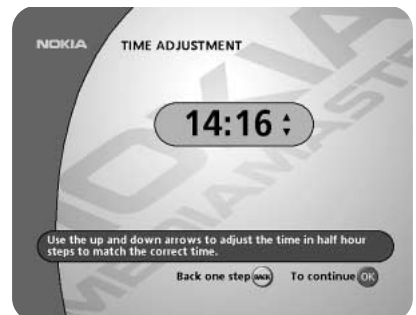

MAIN MENU

Receiver Upgrade

For future update, if any, of the box, it will be possible to download new versions of the system software.

Enter this menu to check for new software. If new software is available you will get information in the menu on how to proceed.

NEVER turn off the Mediamaster, never use the remote control or disconnect the aerial cable during the download procedure! This can damage the software and the receiver will have to be sent in for service!

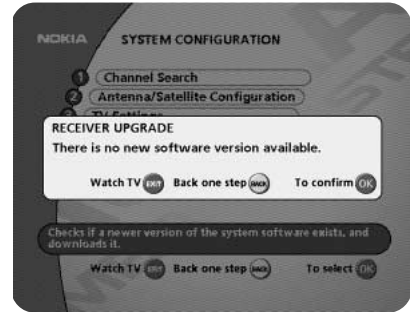

Reinstall

Use this option **only** if you have to start the complete installation procedure from scratch. If you continue from here, **all** your previous settings, parental code and favourite channels etc. will be erased!

If you do not want to change any settings you can leave this menu when the warning is displayed by pressing BACK.



User Preferences

From here you can change the menu language. You also have access to the Parental Control and the Appearance menus.

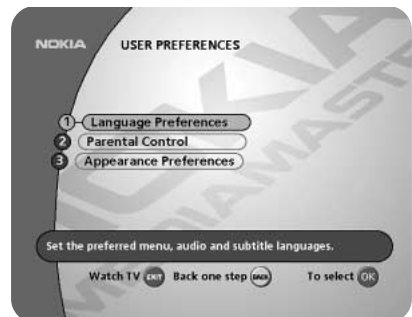

Language Preferences

Menu Language

Here you may select which language the menus will be shown in.

Main and Alternative audio language

If more than one audio language is transmitted, you may select the main and an alternative language.

Subtitles

If you select the **Visible** alternative for subtitling and more than one language is available, you may select a main language and an alternative. In case you want to control the Teletext function with your TV remote control, this parameter must be set to **In-visible**.



MAIN MENU

Parental Control

To open this menu you will be asked to enter your access code. **From the factory the access code is set to 1234.**

The following settings can be altered from this menu.

Receiver lock

If you select **On**, you will have to enter the access code every time you start the Mediamaster from standby.

Age Rating Control

If you want everybody to have access to all available types of programmes, select **Off**.

If you select **On**, you may block programmes unsuitable for children. Select an age limit between 4 and 18 years on the line that appears.

However, you should be aware that not all Service Providers have the necessary codes for these functions implemented in their transmissions.

Change access code

From here you can change the access code from the standard 1234. DO NOT FORGET IT! Without it you do not have access to any of the functions where the code is required!

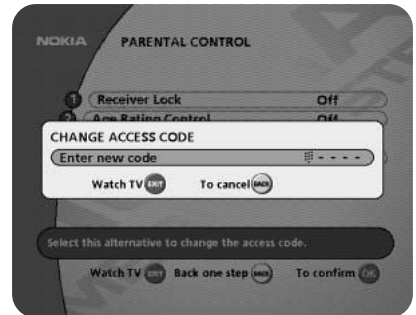
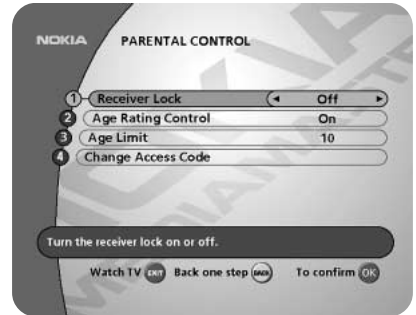

Appearance Preferences

Banner time-out

When you switch channels, an information banner will be shown for a few seconds. You can select for how long the banner will be shown.

Volume bar

Select whether or not you want the volume bar to appear on the screen when you change the volume.

Volume bar time-out

Select how long the banner will be visible on the screen.

Subtitles

Select whether or not subtitles will be visible on the screen. In case you want to control the Teletext function with your TV remote control, this parameter must be set to **Invisible**.

Picture format

If you have a TV set with the 4:3 picture format and the transmission is in 16:9, you can select **Fullscreen** or **Letterbox**.

Fullscreen will fill up the screen but cut off some information on the left and right sides.

Letterbox will give a complete picture, but leave black areas at the top and bottom.

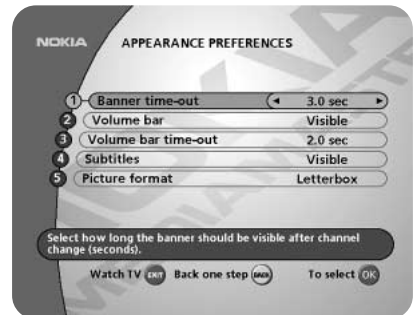

'fullscreen format'



'letterbox format'

MAIN MENU

System Information

If you have to contact your service provider or a service center, they might ask for information available from this menu. Therefore, it is important that you first check the information in the following menus.

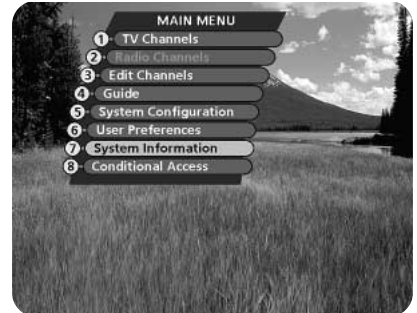

System Information

This gives general information about which hardware and software version your Mediamaster is running on.



Diagnostics

To find out the condition of certain parts of the Mediamaster, you can run a diagnostic test.

The signal input (strength) is measured in Signal-to-Noise ratio (S/N). During normal conditions a S/N level of 18 - 20 dB will be enough to give good picture and sound reception. However, to achieve good reception also during bad weather, atmospheric disturbances or other interferences in the transmission, the signal strength should be higher, something like 25 dB or more.

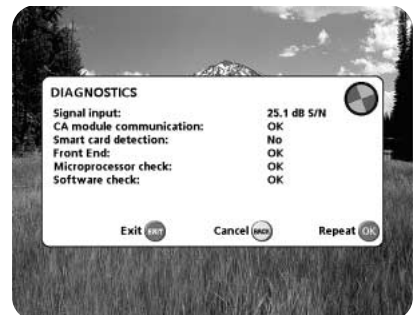

Conditional Access

A menu will only be activated if you have inserted a valid CA module with a Smartcard in the slot behind the front lid.

The picture to the right is only an example of how a CA menu might look like. The menus might differ with different modules. If more than one CA system is activated, select the one from which you want information.

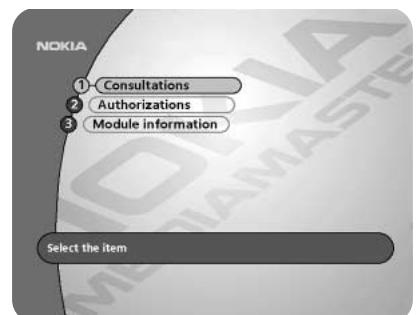

GLOSSARY OF TERMS

Access

Authorisation to use the coding system to purchase / order TV programmes.

Audio system

With digital reception, the sound is transmitted in packages and is selected either in a special audio mode or pre-selected by using the installation set-up. This makes it possible to select between several different languages in a film. The number of choices is dependent on what is available in the transmission.

CA

Conditional Access. A system to control subscriber access to services, programmes and events.

CA module

A device for the decoding of scrambled signals.

Common Interface

Describes a DVB standard hardware and software architecture for Conditional Access systems.

DVB

The Digital Video Broadcast group was created to establish a technical framework for the introduction of digital video broadcasting systems.

EPG

Electronic Programme Guide. A software that enables viewers to navigate easily among the large number of channels provided by digital technology, in order to select the service they desire.

MHz

The prefix mega means million, and Hertz means cycles per second.

MPEG

Moving Picture Experts Group. Body established by the International Standards Organisation to provide the basis for a picture coding and compression system.

Network

A number of digital channels transmitted from one source. Grouped under separate headings in the channel list.

OFDM

Orthogonal Frequency Division Multiplexing. Modulation method used in digital terrestrial networks in Europe.

PCMCIA

Personal Computer Memory Card International Association. The Common Interface slot follows this standard.

Parental control

A feature that allows parents to "lock" programmes that they consider unsuitable for children. A "locked" channel or programme can only be "unlocked" with the special parental access code.

Parental Access code

A four-digit code stored in the Mediamaster. Used to lock the Mediamaster.

PIN code

Personal Identification Number. A four-digit code stored in the Smartcard. For PPV (Pay Per View) or other services together with the subscription.

RF

Radio frequency (known as HF in some countries).

SERIAL RS 232

A serial communication standard data port.

SCART

A 21-pin connector used for connection of the Mediamaster, VCR and TV. Also named Euroconnector or Peritel connector.

Scrambled programme

Some TV programmes are transmitted in scrambled form. A Smartcard, and a CA module, will be needed to view such programmes.

Service provider

Is a company that collects a number of programmes/services and distributes them to customers.

S/PDIF

Sony/Philips digital interface format. Digital audio output.

SW

Software. Programme code.

VCR

Video Cassette Recorder.

PROBLEM SOLVING

Problem	Possible causes	What to do
The display on the front panel does not light up/is not lit.	Mains cable is not connected.	Check that the mains cable is plugged in to the power socket.
No sound or picture, but the front panel shows the time or -- : --.	The Mediamaster is in standby mode.	Press the standby button or any number button to bring the Mediamaster out of standby.
Bad picture/blocking error.	Signal too weak.	Check if the aerial works for analogue reception.
The front panel shows a channel number, but you can't see anything from digital TV.	The Mediamaster is not set in TV mode. The SCART connection has been made wrong or your TV has not selected the correct AV/EXT channel.	If your system is connected by SCART leads, press 0. If this does not work, set the TV to its appropriate AV input. If your system is connected only by RF leads, set your TV to that channel you have tuned for digital terrestrial TV. Check SCART connections, making sure leads are firmly pushed into the sockets. Try manually selecting the AV/EXT channel on your TV.
When the Mediamaster tries to find and store channels during the first installation, a message 'no channels found' is displayed or some channels are missing from the channel list.	The aerial is not properly connected to the Mediamaster. The aerial is not pointing in the right direction. The aerial is not suitable for digital channels. The indoor aerial is not enough. There are no digital transmissions.	Check the aerial connector and the aerial installation. Check if you can see the analogue channels. Check that the aerial is pointing in the right direction. Check that the digital transmissions are available in the area.
Pressing "0" does not switch between a digital channel and an analogue channel.	The system is not connected by SCART leads. The system is RF connected but the TV is not tuned to its channel for digital terrestrial TV.	The TV Release function (0) will only work for SCART connected systems.
There is interference on your digital terrestrial channels, an existing terrestrial channel or video channels.	The system is connected by RF leads and the output channel of the Mediamaster interferes with an existing terrestrial channel or video channel.	Change the Mediamaster output channel to a more suitable channel between 21-69. Or connect the system by SCART leads.
You can't find all the channels you think should be available.	The signal to your aerial may be weak. Your aerial may need adjusting or your local transmitter may not be working.	Try retuning your Mediamaster, following the relevant steps in this manual. If you are still missing channels, your aerial may need adjusting. Contact your dealer or Service Provider. They will check this for you.
There is no Welcome menu on the screen after you switched on the Mediamaster for the first time.	The system is connected by SCART leads and the TV is not in AV/EXT mode. The system is connected by RF leads and the TV is not set to the channel tuned for digital terrestrial TV.	If the system is connected by SCART leads, switch the TV to appropriate AV input. If the system is connected by RF leads, switch the TV to the channel for digital terrestrial TV. If you have not manually tuned in the TV you may do this first. Please look in the TV manual for instructions.

PROBLEM SOLVING

Problem	Possible causes	What to do
You made a video recording of a digital terrestrial channel and whole or parts of the programme was not recorded.	The Mediamaster was not left on the appropriate channel.	If you make a recording of digital terrestrial TV your Mediamaster has to be left on the channel you like to record.
	The system is connected by SCART leads and the VCR is not in AV/EXT mode.	If the system is connected by SCART leads, switch the VCR to appropriate AV input.
The remote control is not working.	The system is connected by RF leads and the VCR is not set to the channel tuned for digital terrestrial TV.	If the system is connected by RF leads, switch the VCR to the channel for digital terrestrial TV. If you have not manually tuned in the VCR you may do this first. Please look in the VCR manual for instructions.
	Battery exhausted. Remote control is incorrectly aimed.	Change the batteries (both). Aim the remote control at box. Check that nothing blocks the front panel.
The remote control is not working.	The Mediamaster is in standby mode.	Check if (.) is flashing on the front panel display when you press a button. If not replace the batteries (both).
	Battery exhausted. Remote control is incorrectly aimed.	Change the batteries (both). Aim the remote control at box. Check that nothing blocks the front panel.
You see the on-screen message. Viewing card faulty.	The Mediamaster can't recognise your smartcard.	Check that you are using the proper Smartcard. Check that the Smartcard has been correctly inserted. If the problem persists, you may have a problem with the card. Contact your dealer or Service Provider.
You have forgotten your secret PIN code.		Contact your Service Provider. They will help you set it up again.
CA Module is not working.	CA module is not installed. CA module is not correctly inserted.	Check that the CA module has been correctly inserted. Contact your dealer or Service Provider.

Please note! The first thing to do before sending the Media-master to service is to:









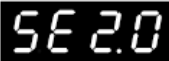

1: Perform "Diagnostic" procedure in System Information menu.

2: Try downloading new software into the Mediamaster. With this procedure, the new software may solve the problem in the quickest and most efficient way. See the relevant section "Receiver Upgrade" further on in this manual.

What to do if you can't solve the problem

Please contact your dealer or Service Provider.

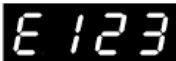
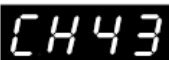
FRONT PANEL DISPLAY

	When power-up, boot version, product family and system software version is shown.		In TV mode.
	When starting from standby, product variant and system software version is shown.		In video mode.
	Remaining time in percent during the download procedure.		When downloading new software via the air.
	The Mediamaster is in standby mode, and current time is shown.		When downloading new software via the Serial RS232 socket.
	Channel number in TV mode.		Error messages. For service personnel
	RF channel in tuning mode.		Lights when no signal is being received. Flashes when pressing a button on the remote control.

TECHNICAL SPECIFICATIONS

Transmission Standards DVB, MPEG 2, OFDM

RF input Modulator output

In-/output connector	IEC female / IEC male
RF input frequency	470 to 862 MHz
RF input power level	-78 to -30 dBm
RF impedance	75 Ω
Frequency range	Loop through 47-862MHz
Frequency range	RF modulator 470-862 MHz
Output channel	UHF CH 21-69
Preset channel	43
Output signal	PAL B/G
Modulation	Supports 2k and 8k

TV SCART

Video output	1 V _{pp} (± 1 dB) / 75 Ω
Audio output	0,5 V _{rms} / R _L > 10 k Ω
RGB output	Internal RGB or from AUX SCART
RGB bandwidth	5,8 MHz ± 3 dB
Fast blanking output	Internal or from AUX SCART
Status output	0/6/12 V / R _L 10 k Ω

AUX SCART

Video output	1 V _{pp} (± 1 dB) / 75 Ω
Video input	1 V _{pp} / 75 Ω
Audio output	0,5 V _{rms} / R _L > 10 k Ω
Audio input	0,5 V _{rms} / R _L > 10 k Ω
Status input	0/6/12 V / R _L > 10 k Ω
Fast blanking input	0/2 V for RGB, bypass to TV SCART
RGB input	Yes

DIGITAL AUDIO (S/PDIF)

Connector	1 x RCA
-----------	---------

AUDIO R L

Connector	2 x RCA (R+L)
Output	0,5 V _{rms} \pm 0,5 dB / R _L 10 k Ω

SERIAL (RS 232) Serial data

Connector	9-pin D-sub male
Signals	RS232, max. 115,2 kbit/s
Pin 1 DCD	(Data carrier detect) not connected
2 RXD	(Receive data)
3 TXD	(Transmit data)
4 DTR	(Data terminal ready) Set to high
5 GND	(Signal ground)
6 DSR	(Data set ready) not connected
7 RTS	(Ready to send)
8 CTS	(Clear to send)
9 RI	(Ring indicator) not connected

Conditional Access system:

One slot for a Common Interface CA module (DVB and PCMCIA Standards).

Front panel

4x7 segment numeric LED display, Buttons: , , 

General data

The model code, variant and serial number, are located on a label on the underside of the housing.

Supply voltage	95-250 V AC, 50-60 Hz
Power consumption max	20 W
Power consumption in standby	3 W
Operating temperature	+5° C to +45° C
Storage temperature	- 40° C to +65° C
Humidity	25 to 75 % rel humidity
Operating distance for remote control	max 10 meters
Dimensions (w x d x h)	380 x 240 x 65 mm
Weight	1,8 kg approx

SCART sockets

TV	AUX
1 Audio out right ch.	Audio out right ch.
2 -	Audio in right ch.
3 Audio out left ch.	Audio out left ch.
4 Audio ground	Audio ground
5 RGB blue ground	RGB blue ground
6 -	Audio in left ch.
7 RGB blue signal out	RGB blue signal in
8 Switch voltage out	Switch voltage in
9 RGB green ground	RGB green ground
10 Connect to pin 10 in AUX scart	
11 RGB green signal out	RGB green signal in
12 -	-
13 RGB red ground	RGB red ground
14 Fast blank. ground	Fast blank. ground
15 RGB red signal out	RGB red signal in
16 Fast blanking out	Fast blanking in
17 Video out ground	Video out ground
18 -	Video in ground
19 Video out	Video out
20 -	Video in
21 Ground (casing)	Ground (casing)





Nokia is a registered trademark of Nokia Corporation

www.nokia.com



66 76989-10

© 0142