



## TECHNICAL GUIDE

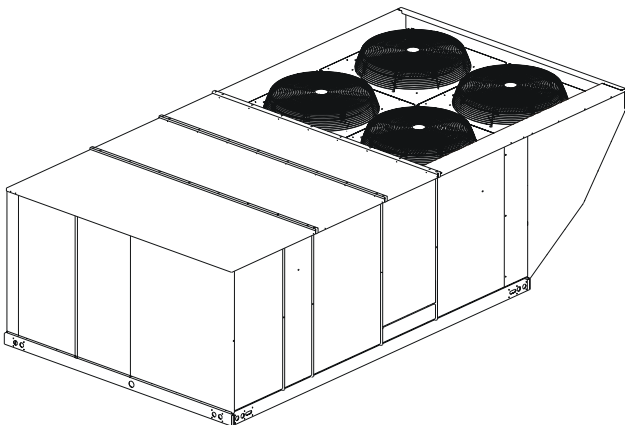
### SERIES 20

### SINGLE PACKAGE GAS/ELECTRIC UNITS AND SINGLE PACKAGE AIR CONDITIONERS

J15, 18, 20 & 25 DJ

15 & 25 NOMINAL TONS

12.00 EER (15 TONS), 11.70 EER (17.5 TONS),  
11.3 EER (20 TONS), 10.5 EER (25 TONS)



### DESCRIPTION

Johnson Controls Series 20 J\*\*DJ units are convertible single package high efficiency rooftops. All models have independent dual refrigerant circuits for efficient part load operation. Although the units are primarily designed for curb mounting on a roof, they can also be slab-mounted at ground level or set on steel beams above a finished roof.

All units include:

- Powder Paint finish that meets ASTM-B-117 750 hour salt spray standards
- Two-stage cooling provided by dual independent refrigeration circuits with expansion valves, filter-driers, high and low pressure/loss of charge switches and freezestats
- Scroll compressors
- Two-stage heating provided by dual independent heat exchangers with aluminized steel tubes, redundant gas valves, spark ignition with induced draft logic
- Permanently lubricated motors
- Bottom or side air discharge configuration capability (field convertible)
- Belt Drive Blower Motor with high static drive option
- Constant supply air volume (CV) with optional variable air volume (VAV)
- Manufactured under the quality standards of ISO9001
- Zero-25% fixed air damper with hood
- Copper tube/aluminum fin coils
- Hinged filter access and tool free latched doors
- Hinged tool free blower, blower motor, filters and electrical panel access
- Rigging holes in base rails for lifting
- Single point power connection
- Complete factory package - tested, charged and wired
- CSA agency approvals on all units

### WARRANTY

- One-year parts warranty
- A Five-year parts warranty on the compressors and electric heat elements
- Ten-year parts warranty on the gas-fired heat exchangers



## TABLE OF CONTENTS

DESCRIPTION . . . . .	1	<u>Tbl. #</u>	<u>Pg. #</u>
<b>PRODUCT NOMENCLATURE . . . . .</b>	<b>3</b>	8 ALTITUDE CORRECTION FACTORS . . . . .	14
<b>FEATURES . . . . .</b>	<b>4</b>	9 SUPPLY AIR BLOWER PERFORMANCE (15 TON) - COOLING ONLY 180 MBH - BOTTOM DUCT CONNECTIONS . . . . .	16
<b>FACTORY-INSTALLED OPTIONS . . . . .</b>	<b>5</b>	10 SUPPLY AIR BLOWER PERFORMANCE (17.5 TON) - COOLING ONLY 210 MBH - BOTTOM DUCT CONNECTIONS . . . . .	17
<b>FIELD-INSTALLED ACCESSORIES . . . . .</b>	<b>7</b>	11 SUPPLY AIR BLOWER PERFORMANCE (20 TON) - COOLING ONLY 240 MBH - BOTTOM DUCT CONNECTIONS . . . . .	18
<b>GUIDE SPECIFICATIONS . . . . .</b>	<b>37</b>	12 SUPPLY AIR BLOWER PERFORMANCE (15 TON) - GAS HEAT 180 MBH - BOTTOM DUCT CONNECTIONS . . . . .	19
		13 SUPPLY AIR BLOWER PERFORMANCE (17.5 TON) - GAS HEAT 210 MBH - BOTTOM DUCT CONNECTIONS . . . . .	20
		14 SUPPLY AIR BLOWER PERFORMANCE (20 TON) - GAS HEAT 240 MBH - BOTTOM DUCT CONNECTIONS . . . . .	21
		15 SUPPLY AIR BLOWER PERFORMANCE (25 TON) - GAS HEAT 300 MBH - BOTTOM DUCT CONNECTIONS . . . . .	22
		16 BLOWER MOTOR AND DRIVE DATA . . . . .	23
		17 STATIC RESISTANCES . . . . .	23
		18 POWER EXHAUST PERFORMANCE . . . . .	23
		19 J**DJ ELECTRICAL DATA WITHOUT POWERED CONVENIENCE OUTLET . . . . .	24
		20 J**DJ ELECTRICAL DATA WITH POWERED CONVENIENCE OUTLET . . . . .	26
		21 J**DJ VOLTAGE LIMITATIONS . . . . .	28
		22 PHYSICAL DATA . . . . .	28
		23 SUPPLY FAN VFD WEIGHTS, IN LBS. . . . .	29
		24 ELECTRIC HEAT CORRECTION FACTORS . . . . .	29
		25 UTILITIES ENTRY DATA . . . . .	30
		26 MINIMUM CLEARANCES . . . . .	32
		27 FOUR AND SIX POINT LOADS . . . . .	34

### LIST OF FIGURES

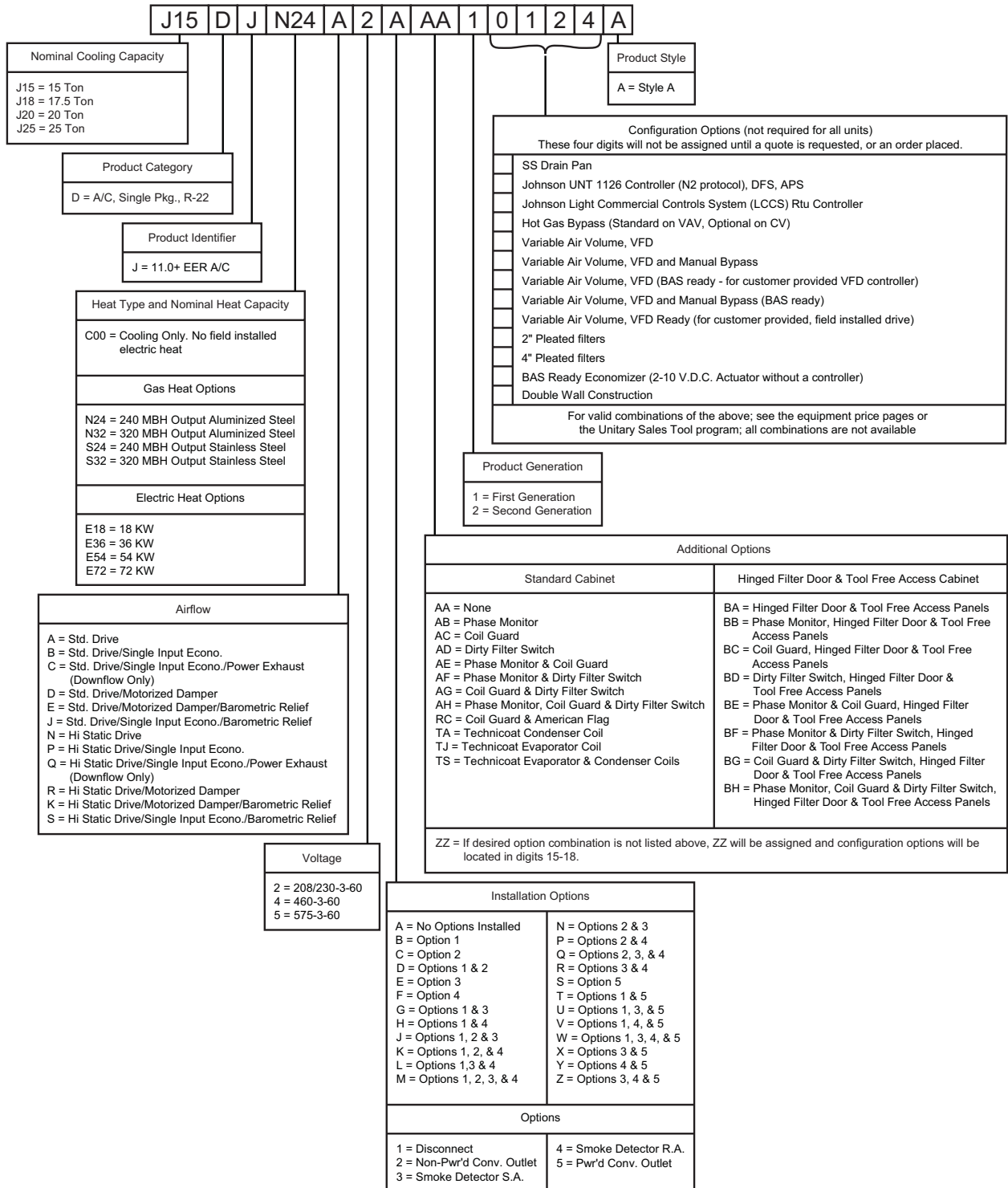
<u>Fig. #</u>	<u>Pg. #</u>
1 UNIT CUTAWAY . . . . .	5
2 ALTITUDE/TEMPERATURE CONVERSION FACTOR . . . . .	15
3 TYPICAL J**DJ FIELD WIRING DIAGRAM . . . . .	29
4 FRONT VIEW DIMENSIONS . . . . .	30
5 REAR VIEW DIMENSIONS . . . . .	31
6 UNIT DIMENSIONS J15, 18, 20 & 25 DJ (RAINHOOD). . . . .	32
7 UNIT CENTER OF GRAVITY . . . . .	33
8 TYPICAL UNIT APPLICATIONS . . . . .	33
9 FOUR AND SIX POINT LOADS . . . . .	34
10 UNIT ROOF CURB DIMENSIONS . . . . .	35
11 ROOF CURB DUCT OPENINGS DIMENSION . . . . .	35
12 CUT AWAY OF ROOF CURB . . . . .	35
13 TYPICAL UNIT WIRING DIAGRAM . . . . .	36

### LIST OF TABLES

<u>Tbl. #</u>	<u>Pg. #</u>
1 SOUND POWER RATING . . . . .	9
2 CAPACITY RATINGS - (ARI 360) . . . . .	9
3 GAS HEAT RATINGS . . . . .	9
4 COOLING CAPACITIES FOR J15DJ . . . . .	10
5 COOLING CAPACITIES FOR J18DJ . . . . .	11
6 COOLING CAPACITIES FOR J20DJ . . . . .	12
7 COOLING CAPACITIES FOR J25DJ . . . . .	13

# PRODUCT NOMENCLATURE

## 15-25 Ton Series 20 Model Number Nomenclature



## FEATURES

All Series 20 J\*\*DJ models are available with a wide variety of factory-mounted options such as stainless steel heat exchangers, phase monitor, dirty filter switch, and coil guard to make them suitable for almost every application.

All units are self-contained and assembled on full perimeter base rails with holes in the four corners for overhead rigging. Every unit is completely piped, wired, charged and tested at the factory to simplify the field installation and to provide years of dependable operation.

All models (including those with an economizer) are suitable for either bottom or horizontal duct connections. **Models with factory installed power exhaust are suitable for bottom duct connections only.** For bottom duct, you remove the sheet metal panels from the supply and return air openings through the base of the unit. For horizontal duct, you replace the supply and return air panels on the rear of the unit with a side duct flange accessory.

All models are available with these “factory mounted” outdoor air damper options:

- Single enthalpy economizer with or without power exhaust
- BAS-ready economizer with or without power exhaust
- Motorized outdoor air damper
- Barometric Relief Damper

A fixed outdoor air intake assembly will be shipped in the return air compartment of all units ordered without an economizer or motorized outdoor air damper option. The assembly includes a rain hood with a damper that can be set for 10, 15 or 25% outdoor air. With bottom duct connections, the intake damper assembly should be mounted over the opening in the return air panel. With horizontal ductwork, it should be mounted on the return air duct.

All supply air blowers are equipped with a belt drive that can be adjusted to meet the exact requirements of the job. A high static drive option is available for applications with a higher CFM and/or static pressure requirement. A variable air volume (VAV) option using a variable frequency drive is available for applications requiring a constant supply duct pressure. A differential pressure transducer is used to monitor supply duct static pressure and return a speed reference signal to the VFD to control the output of the indoor blower motor.

All compressors include scroll compressors and internal pressure relief. Every refrigerant circuit includes an expansion valve, a liquid line filter-drier, a discharge line high pressure switch and a suction line with a freeze-stat and low pressure/loss of charge switch to protect all system components. A hot gas bypass option, consisting of an adjustable compressor discharge bypass valve, is available for low cooling load applications.

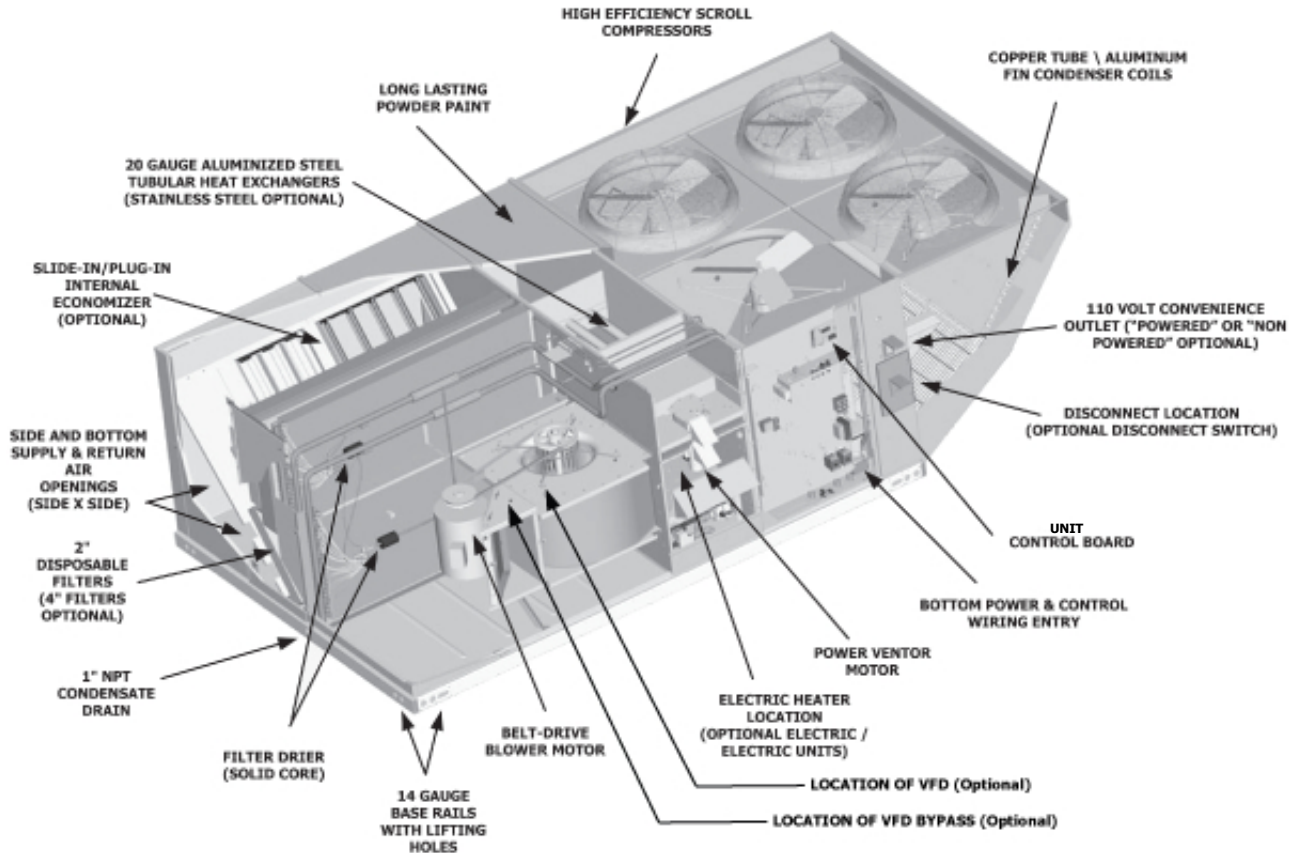
- **Advanced Controls** - Unit control boards have standardized a number of features previously available only as options or by utilizing additional controls.

- **Low Ambient** - An integrated low-ambient control allows all units to operate in the cooling mode down to 0°F outdoor ambient without additional assistance. Optionally, the control board can be programmed to lockout the compressors when the outdoor air temperature is low or when free cooling is available.
- **Anti-Short Cycle Protection** - To aid compressor life, an anti-short cycle delay is incorporated into the standard controls. Compressor reliability is further ensured by programmable minimum run times. For testing, the anti short cycle delay can be temporarily overridden with the push of a button.
- **Lead-Lag** - An integrated Lead-Lag option allows equal run time hours on all compressors, thereby extending the life of all compressors. This option is selectable on the unit control board.
- **Fan Delays** - Fan on and fan off delays are fully programmable. Furthermore, the heating and cooling fan delay times are independent of one another. All units are programmed with default values based upon their configuration of cooling and heat.
- **Safety Monitoring** - The control board monitors the high and low-pressure switches, the freeze-stats, the gas valve, if applicable, and the temperature limit switch on gas and electric heat units. The unit control board will alarm on ignition failures, compressor lockouts and repeated limit switch trips.
- **Nuisance Trip Protection and Strikes** - To prevent nuisance trouble calls, the control board uses a “three times, you’re out” philosophy. The high and low-pressure switches and the freeze-stats must trip three times within two hours before the unit control board will lock out the associated compressor.
- **On Board Diagnostics** - Each alarm will energize a trouble light on the thermostat, if so equipped, and flash an alarm code on the control board LED. Each high and low-pressure switch alarm as well as each freeze-stat alarm has its own flash code. The control board saves the five most recent alarms in memory, and these alarms can be reviewed at any time. Alarms and programmed values are retained through the loss of power.

All units have long lasting powder paint cabinets with 750 hour salt spray test approval under ASTM-B117 procedures.

All models are CSA approved.

- **Warranty** - All models include a one-year limited parts warranty on the complete unit. Compressors and electric heater elements carry a five-year warranty. Gas heat exchangers carry a 10-year parts warranty.
- **Gas Heat Operation** - All gas heat units are built with two heating sections for two equal stages of capacity control. Each section includes a durable heat exchanger



**FIGURE 1 - UNIT CUTAWAY**

with aluminized steel or optional stainless steel tubes, a redundant gas valve, spark ignition, power venting, an ignition module for 100% shut-off and all of the safety controls required to meet the latest ANSI standards.

The gas supply piping can be routed into the heating compartment through a hole in the base pan of the unit or through a knockout in the piping panel on the front of the unit.

- **Electric Heat Operation** - All electric heat models (factory installed only) are wired for a single power source and include a bank of nickel chromium elements mounted at the discharge of the supply air blower to provide a high velocity and uniform distribution of air across the heating elements. Every element is fully protected against excessive current and temperature by fuses and two thermal limit switches.

The power supply wiring can be routed into the control box through a threaded pipe connection in the base pan of the unit or through a knockout in the wiring panel on the front of the unit.

## FACTORY-INSTALLED OPTIONS

- **SINGLE INPUT ELECTRONIC ENTHALPY ECONOMIZERS** - Includes a slide-in / plug-in damper assembly with fully modulating spring-return motor actuator capa-

ble of introducing up to 100% outdoor air with nominal 1% leakage type dampers.

The enthalpy system contains one sensor that monitors the outdoor air and determines when the air is cool enough and dry enough to provide free cooling.

The rainhood is painted to match the basic unit and must be field-assembled before installing.

- **BAS-READY ECONOMIZER** - Includes a slide-in / plug-in damper assembly with fully modulating spring-return motor actuator with zero to 95-degree rotation capable of introducing up to 100% outdoor air with nominal 1% leakage type dampers.

Actuator requires 2-10 VDC input from an external source, such as a field-installed or factory-installed BAS controller. BAS-ready actuators have an adjustable auxiliary end-switch for optional power exhaust control.

For units with optional VAV control, a factory-installed, dry bulb sensor determines if outdoor air temperature is low enough to provide free-cooling operation. (Field-installed humidity sensors for either outdoor air or outdoor & return air streams are available for single enthalpy and differential enthalpy configurations, respectively).

The rainhood is painted to match the basic unit and must be field-assembled before installing.

- **POWER EXHAUST** - Our economizer options are available with power exhaust. Whenever the outdoor air intake dampers are opened for free cooling, the exhaust fan will be energized to prevent the conditioned space from being over-pressurized during economizer operation. BAS-ready economizer actuators have an adjustable auxiliary end-switch to provide a range of damper positions available to energize power exhaust.

The exhaust fan, motor and controls are installed and wired at the factory. The rain hood must be assembled and installed in the field.

**The power exhaust option can only be used on bottom duct configurations.**

- **MOTORIZED OUTDOOR AIR INTAKE DAMPER** - Includes a slide-in / plug-in damper assembly with a 2-position, spring return motor actuator which opens to a pre-set position whenever the supply air blower is operating and will drive fully closed when the blower unit shuts down.  
  
The rain hood is painted to match the basic unit and must be field assembled before installing.
- **BAROMETRIC RELIEF DAMPER** - This damper option can be used to relieve internal building air pressure on units with an economizer without power exhaust. This accessory includes a rain hood, a bird screen and a fully assembled damper. With bottom duct connections, the damper should be mounted over the opening in the return air panel. With horizontal ductwork, the accessory should be mounted on the return air duct.
- **PHENOLIC COATED EVAPORATOR AND CONDENSER COILS** - Special coating process that utilizes Technicoat 10-1" processes. Coating is applied by total immersion of the complete coil for maximum protection.
- **ELECTRIC HEATERS** wired for single point power supply. These nickel chromium heater elements are provided with limit and automatic reset capability to prevent operation at excessive temperatures.
- **VARIABLE AIR VOLUME (VAV)** - A factory-installed variable frequency drive (VFD), mounted in the Blower Access compartment, is used to control the speed of the indoor blower motor in order to maintain a constant static pressure in the supply duct. A pressure transducer and VAV control board are mounted inside the control box. The drive comes completely wired and pre-programmed from the factory.

An optional, factory-installed manual bypass switch available with factory-installed VFD can be found in the Blower Motor Access compartment. The switch can be used to either route power to the VFD for modulating control of the blower motor, to bypass the drive and operate the motor at full speed, or to power the drive (and not the motor) for diagnostic purposes.

Due to space limitations, VAV is not available with any of the factory-installed BAS options described below, but is available with 'BAS-ready' models. Terminal blocks are provided in the control box for field wiring of the customer-installed BAS.

A 'VFD-ready' option provides the provisions for a customer-installed drive. The unit comes with a mounting bracket installed in the Blower Access compartment which may accommodate other vendor's drives depending on their size. In order to utilize the unit's mounting bracket, the maximum recommended drive dimensions are as follows:

For 5-hp motor applications .....13" H x 6" W x 7" D

For 7.5 thru 15-hp motor applications .....13" H x 8" W x 8" D

If the drive will not fit in the allotted space, then it will have to be mounted elsewhere; either within the building on a perpendicular wall which is not subjected to excessive temperature, vibration, humidity, dust, corrosive gas, explosive gas, etc., or within an appropriate enclosure rated for outside installation to safeguard against moisture, dust and excessive heat.

A terminal block located in the control box is provided for field connection of the VFD controls.

- **HOT GAS BYPASS** - To allow for low cooling load operation, a direct-acting pressure-modulating bypass control valve installed on the system #1 discharge line is used to divert high temperature, high pressure refrigerant around the TXV in order to maintain a desired minimum evaporator pressure. HGBP is standard on all units with VAV and optional with CV units.
- **FILTER OPTIONS** - Standard units are shipped with 2" throw-away filters installed. 2" pleated and 4" pleated filters are offered as a factory installed option.
- **CONVENIENCE OUTLET** - This 110 volt outlet can be "powered" by the unit with a stepdown transformer or you may order the unit with a "non-powered" convenience outlet that can be wired in the field.
- **DISCONNECT SWITCH** - For gas heat units and cooling units with electric heat, a HACR breaker sized to the unit is provided. For cooling only units, a switch sized to the largest electric heat available for the particular unit is provided. Factory installed option only.
- **DOUBLE WALL CONSTRUCTION** - Optional double wall construction is available to provide smooth inner surfaces for easy and effective cleaning to reduce risk of dirt and bacterial accumulation. Fiberglass insulation is sandwiched between heavy gauge steel sheets to form a durable, rigid casing to withstand higher working pressures and impact forces. The heavy-duty construction provides excellent acoustic and thermal insulation and eliminates erosion of insulation material and contamination of the air stream.

- **SMOKE DETECTORS** - (supply air & return air) The smoke detectors stop operation of the unit by interrupting power to the control board if smoke is detected within the air compartment.

### **WARNING**

Factory installed smoke detectors in the return air may be subjected to freezing temperatures during "off" times due to outside air infiltration. These smoke detectors have an operation limit of 32°F to 131°F. Smoke detectors installed in areas that could be outside those limitations will have to be moved to prevent having false alarms.

- **COIL GUARD** - Customers can purchase a coil guard kit to protect the condenser coil from damage. This is not a hail guard kit.
- **STAINLESS STEEL HEAT EXCHANGER** - For applications in corrosive environments, this option provides a full stainless steel heat exchanger assembly.
- **STAINLESS STEEL DRAIN PAN** - An optional rust-proof stainless steel drain pan is available to provide years of trouble-free operation in corrosive environments.
- **PHASE MONITORS** - Designed to prevent unit damage. The phase monitor will shut the unit down in an out-of-phase condition.
- **HIGH STATIC DRIVE** - Includes a belt and blower pulley upgrade to enhance blower performance.
- **DIRTY FILTER SWITCH** - This kit includes a differential pressure switch that energizes the fault light on the unit thermostat, indicating that there is an abnormally high pressure drop across the filters. Factory installed option or field installed accessory.
- **HINGED FILTER DOOR/"TOOL FREE" BLOWER AND ACCESS PANELS (not hinged)** - This option allows for easy access and maintenance.  
**NOTE:** Knobs are shipped separately within the unit to prevent shipping damage. These must be field installed for tool free operation.
- **HINGED/"TOOL FREE" BLOWER, BLOWER MOTOR, FILTER AND ELECTRIC ACCESS PANELS** - This option allows for complete hinged and tool free access to the unit's blower, blower motor, filters and electrical panel sections.

## CONTROL OPTIONS

- **Johnson Light Commercial System (LCCS)** - Provides rooftop system integration for LCCS single zone, change-over bypass and VAV systems.

- **Johnson UNT 1126 Rooftop Controller** - N2 protocol with air proving and dirty filter sensors. Hardware contains generic application logic; field engineering and/or modification may be required.

## FIELD-INSTALLED ACCESSORIES

- **SINGLE INPUT ELECTRONIC ENTHALPY ECONOMIZERS** - Includes a slide-in / plug-in damper assembly with fully modulating spring-return motor actuator capable of introducing up to 100% outdoor air with nominal 1% leakage type dampers.

The enthalpy system contains one sensor that monitors the outdoor air and determines when the air is cool enough and dry enough to provide free cooling.

The rainhood is painted to match the basic unit and must be field-assembled before installing.

- **MOTORIZED OUTDOOR AIR INTAKE DAMPER** - Includes a slide-in / plug-in damper assembly with a 2-position, spring return motor actuator which opens to some pre-set position whenever the supply air blower is operating and will drive fully closed when the blower unit shuts down.

The rain hood is painted to match the basic unit and must be field assembled before installing.

- **ROOF CURBS** - Fourteen-inch high roof curbs provide a water-tight seal between the unit and the finished roof. These full perimeter curbs meet the requirements of the National Roofing Contractors Association (NRCA) and are shipped knocked-down for field assembly.

They're designed to fit inside the base rails of the unit and include both a wood nailing strip and duct hanger supports.

- **HIGH ALTITUDE NATURAL GAS** - Burner orifices and pilot orifices are provided for proper furnace operation at altitudes up to 6,000 feet.
- **PROPANE** - Burner orifices, pilot orifices and gas valve parts are provided to convert a natural gas furnace to propane.
- **HIGH ALTITUDE PROPANE** - Burner orifices and pilot orifices are provided for proper furnace operation at altitudes up to 6,000 feet. This accessory supplements the basic propane conversion kit.
- **SIDE DUCT FLANGES** - One-inch flanges replace the supply and return air panels on the rear of the unit to accommodate horizontal duct connections. These flanges can also be used individually for bottom supply/horizontal return or horizontal supply/bottom return. They cannot be used on units with power exhaust.
- **BAROMETRIC RELIEF DAMPER** - This damper accessory can be used to relieve internal building air pressure on units with an economizer without power exhaust. This

accessory includes a rain hood, a bird screen and a fully assembled damper. With bottom duct connections, the damper should be mounted over the opening in the return air panel. With horizontal ductwork, the accessory should be mounted on the return air duct.

- **HIGH STATIC DRIVE** - A smaller blower pulley and a shorter belt increase the speed of the supply air blower for applications with a higher CFM and/or static pressure requirements.
- **ENTHALPY ACCESSORY CONTROL KIT** - This kit contains the required components to convert a single enthalpy economizer to dual enthalpy.
- **BURGLAR BARS** - Mount in the supply and return openings to prevent entry into the duct work.
- **FLUE EXHAUST EXTENSION KIT** - In locations with wind or weather conditions which may interfere with proper exhausting of furnace combustion products, this kit can be installed to prevent the flue exhaust from entering nearby fresh air intakes.
- **WOOD SKID** - Allows unit to be handled with 90" forks.
- **CO<sub>2</sub> SENSOR** - Senses CO<sub>2</sub> levels and automatically overrides the economizer when levels rise above the present limits.
- **COIL GUARD** - Customers can purchase a coil guard kit to protect the condenser coil from damage. This is not a hail guard kit.
- **PHASE MONITORS** - Designed to prevent unit damage. The phase monitor will shut the unit down in an out-of-phase condition.



**TABLE 1: SOUND POWER RATING<sup>1</sup>**

UNIT SIZE	CFM	ESP	BLOWER		SOUND POWER (db 10 <sup>-12</sup> Watts)									
					Octave Band Centerline Frequency (Hz)								SWL dB(A)	dB(A) @ 10Ft. <sup>2</sup>
					IWG	RPM	BHP	63	125	250	500	1,000		
J15DJ	6,000	1.00	1,080	4.60	99	99	89	82	84	77	72	67	89	56
J18, 20 DJ	8,000	1.00	1,120	6.65	102	102	92	85	87	80	75	70	92	59
J25DJ	10,000	1.30	1160	12.5	108	108	98	91	93	86	81	76	98	65

1. These values have been accessed using a model of sound propagation from a point source into the hemispheric/free field. The dBA values provided are to be used for reference only. Calculation of dBA values cover matters of system design and the fan manufacture has no way of knowing the details of each system. This constitutes an expectation to any specification or guarantee requiring a dBA value or sound data in any other form than sound power level ratings.
2. At a distance of 10 feet from the blower.

**TABLE 2: CAPACITY RATINGS - (ARI 360)<sup>1</sup>**

MODEL	MBH	EER <sup>2</sup>	IPLV <sup>3</sup>
<b>COOLING ONLY</b>			
J15DJC/E00	178	12.0	12.5
J18DJC/E00	208	11.7	12.7
J20DJC/E00	230	11.3	12.0
J25DJC/E00	292	10.5	11.2
<b>COOLING WITH GAS HEAT</b>			
J15DJN/S	178	12.0	12.5
J18DJN/S	208	11.7	12.7
J20DJN/S	230	11.3	12.0
J25DJN/S	292	10.5	11.2
<b>COOLING WITH ELECTRIC HEAT</b>			
J15DJE18	178	12.0	12.5
J15DJE36	178	12.0	12.5
J15DJE54	176	11.8	12.2
J15DJE72	176	11.8	12.2
J18DJE18	208	11.7	12.7
J18DJE36	208	11.7	12.7
J18DJE54	206	11.5	12.4
J18DJE72	206	11.5	12.4
J20DJE18	230	11.3	12.0
J20DJE36	230	11.3	12.0
J20DJE54	228	11.1	11.7
J20DJE72	228	11.1	11.7
J25DJE18	292	10.5	11.2
J25DJE36	292	10.5	11.2
J25DJE54	290	10.3	11.0
J25DJE72	290	10.3	11.0

1. Certified in accordance with the Unitary Large Equipment certification program which is based on ARI Standard 340/360.
2. EER = Energy Efficiency Ratio at full load - the cooling capacity in Btu's per hour (Btuh) divided by the power input in watts, expressed in Btuh per watt (Btuh/watt).
3. IPLV = Integrated Part Load Value.

**TABLE 3: GAS HEAT RATINGS**

MODEL	MBH INPUT	MBH OUTPUT
J15DJN/S24	300	240
J15DJN/S32	400	320
J18DJN/S24	300	240
J18DJN/S32	400	320
J20DJN/S24	300	240
J20DJN/S32	400	320
J25DJN/S24	300	240
J25DJN/S32	400	320

NOTE: All gas units are two-stage heating.  
First stage is 50% of total.  
S.S.E. = Steady State Efficiency (80%) - output divided by input.

### CAUTION

For units with VFD and electric or gas heat, the speed of the indoor blower motor continues to be controlled by duct static pressure via the VAV control board.

If there are VAV boxes present in the duct system, the boxes must be driven to the full-open position using a customer-supplied power source to assure adequate airflow across electric heating elements or gas heat exchanger tubes.

TABLE 4: COOLING CAPACITIES FOR J15DJ

Air on Evaporator Coil		Temperature of Air on Condenser Coil																	
		85°F								95°F									
		Total Cap. <sup>1</sup> (MBH)	Total <sup>2</sup> Input (kW)	Sensible Capacity (MBH) <sup>*</sup> Return Dry Bulb (°F)						Total Cap. <sup>1</sup> (MBH)	Total <sup>2</sup> Input (kW)	Sensible Capacity (MBH) <sup>*</sup> Return Dry Bulb (°F)							
CFM	WB (°F)	86	83	80	77	74	71	68	86	83	80	77	74	71	68				
4500	72	206.8	11.94	119.7	106.8	94.0	81.2	68.3	-	-	196.1	12.98	115.7	102.9	90.1	77.3	64.4	-	-
	67	187.4	11.64	148.6	135.7	122.9	110.1	97.2	84.4	71.6	178.1	12.70	144.6	131.8	119.0	106.1	93.3	80.5	67.6
	62	169.3	11.37	169.3	162.1	149.3	136.5	123.6	110.8	98.0	161.7	12.49	161.7	157.0	144.2	131.4	118.5	105.7	92.9
	57	166.8	11.36	166.8	164.1	151.3	138.5	125.6	112.8	100.0	163.4	12.53	163.4	160.3	147.5	134.7	121.8	109.0	96.2
5250	72	212.8	12.00	132.2	117.0	101.8	86.7	71.5	-	-	201.2	13.06	127.9	112.7	97.6	82.4	67.2	-	-
	67	192.8	11.70	163.5	148.3	133.2	118.0	102.8	87.7	72.5	182.8	12.78	159.2	144.0	128.8	113.7	98.5	83.3	68.2
	62	174.2	11.43	174.2	170.7	161.7	146.6	131.4	116.3	101.1	166.0	12.57	166.0	163.6	156.2	141.0	125.9	110.7	95.5
6000	72	218.9	12.06	144.7	127.2	109.7	92.2	74.7	-	-	206.4	13.14	140.0	122.5	105.1	87.6	70.1	-	-
	67	198.3	11.76	178.4	160.9	143.4	125.9	108.4	90.9	73.4	187.5	12.86	173.7	156.2	138.7	121.2	103.7	86.2	68.7
	62	179.2	11.49	179.2	179.2	174.2	156.7	139.2	121.7	104.2	170.2	12.65	170.2	170.2	168.2	150.7	133.2	115.7	98.2
	57	176.5	11.48	176.5	176.5	176.5	159.0	141.5	124.0	106.6	172.0	12.69	172.0	172.0	172.0	154.5	137.0	119.5	102.0
6600	72	224.3	12.14	156.2	136.7	117.2	97.8	78.3	-	-	211.4	13.22	150.4	131.0	111.5	92.0	72.5	-	-
	67	203.2	11.83	192.2	172.8	153.3	133.8	114.3	94.9	75.4	192.0	12.93	185.1	166.7	147.2	127.7	108.2	88.8	69.3
	62	183.6	11.57	183.6	183.6	181.1	161.7	142.2	122.7	103.2	174.3	12.72	174.3	174.3	173.3	153.8	134.4	114.9	95.4
	57	180.9	11.56	180.9	180.9	180.9	161.4	141.9	122.5	103.0	176.2	12.76	176.2	176.2	176.2	156.7	137.2	117.7	98.3
7200	72	229.7	12.22	167.7	146.3	124.8	103.3	81.9	-	-	216.4	13.30	160.8	139.4	117.9	96.4	75.0	-	-
	67	208.1	11.91	206.1	184.6	163.2	141.7	120.3	98.8	77.3	196.6	13.01	196.6	177.1	155.7	134.2	112.8	91.3	69.8
	62	188.1	11.64	188.1	188.1	188.1	166.6	145.1	123.7	102.2	178.5	12.80	178.5	178.5	178.5	157.0	135.6	114.1	92.6
	57	185.3	11.63	185.3	185.3	185.3	163.8	142.3	120.9	99.4	180.4	12.84	180.4	180.4	180.4	158.9	137.4	116.0	94.5
105°F																			
4500	72	184.9	14.46	111.3	98.5	85.6	72.8	60.0	-	-	173.7	15.93	106.8	94.0	81.2	68.3	55.5	-	-
	67	167.9	14.19	140.0	127.2	114.3	101.5	88.7	75.9	63.0	157.7	15.68	135.4	122.6	109.7	96.9	84.1	71.2	58.4
	62	152.9	14.00	152.9	149.0	136.2	123.4	110.5	97.7	84.9	144.1	15.50	144.1	141.0	128.2	115.4	102.5	89.7	76.9
	57	155.3	14.03	155.3	152.1	139.3	126.5	113.6	100.8	88.0	147.3	15.53	147.3	143.9	131.1	118.3	105.4	92.6	79.8
5250	72	189.7	14.51	123.4	108.2	93.1	77.9	62.7	-	-	178.3	15.95	118.9	103.7	88.6	73.4	58.2	-	-
	67	172.3	14.24	154.6	139.5	124.3	109.1	94.0	78.8	63.6	161.8	15.70	150.1	134.9	119.8	104.6	89.4	74.3	59.1
	62	156.9	14.05	156.9	155.0	148.1	132.9	117.7	102.6	87.4	147.8	15.52	147.8	146.3	139.9	124.8	109.6	94.4	79.3
6000	72	194.6	14.56	135.5	118.0	100.5	83.0	65.5	-	-	182.8	15.97	131.0	113.5	96.0	78.5	61.0	-	-
	67	176.7	14.29	169.2	151.7	134.2	116.7	99.3	81.8	64.3	166.0	15.72	164.8	147.3	129.8	112.3	94.8	77.3	59.8
	62	160.9	14.09	160.9	160.9	159.9	142.4	124.9	107.4	89.9	151.6	15.54	151.6	151.6	151.6	134.1	116.6	99.1	81.6
	57	163.5	14.13	163.5	163.5	163.5	146.0	128.5	111.0	93.5	155.0	15.56	155.0	155.0	155.0	137.5	120.0	102.6	85.1
6600	72	193.9	14.65	126.3	106.8	87.3	67.8	-	-	-	187.1	16.07	141.1	121.6	102.1	82.6	63.1	-	-
	67	180.9	14.38	177.2	162.1	142.6	123.1	103.7	84.2	64.7	169.9	15.82	169.3	157.5	138.1	118.6	99.1	79.6	60.1
	62	164.8	14.18	164.8	164.8	164.3	144.8	125.3	105.8	86.3	155.2	15.64	155.2	155.2	155.2	135.7	116.2	96.8	77.3
	57	167.4	14.21	167.4	167.4	167.4	148.0	128.5	109.0	89.5	158.7	15.66	158.7	158.7	158.7	139.2	119.7	100.3	80.8
7200	72	203.9	14.74	156.0	134.5	113.1	91.6	70.1	-	-	191.5	16.18	151.2	129.7	108.2	86.8	65.3	-	-
	67	185.2	14.47	185.2	172.5	151.0	129.5	108.1	86.6	65.2	173.8	15.93	173.8	167.8	146.3	124.9	103.4	81.9	60.5
	62	168.6	14.27	168.6	168.6	168.6	147.2	125.7	104.2	82.8	158.8	15.74	158.8	158.8	158.8	137.3	115.9	94.4	72.9
	57	171.4	14.30	171.4	171.4	171.4	149.9	128.4	107.0	85.5	162.4	15.77	162.4	162.4	162.4	140.9	119.4	98.0	76.5
125°F																			
4500	72	162.5	17.41	102.4	89.5	76.7	63.9	51.0	-	-	-	-	-	-	-	-	-	-	-
	67	147.5	17.18	130.8	118.0	105.1	92.3	79.5	66.6	53.8	-	-	-	-	-	-	-	-	-
	62	135.2	17.00	135.2	133.0	120.2	107.4	94.5	81.7	68.9	-	-	-	-	-	-	-	-	-
	57	139.2	17.02	139.2	135.7	122.9	110.1	97.2	84.4	71.6	-	-	-	-	-	-	-	-	-
5250	72	166.8	17.40	114.4	99.2	84.1	68.9	53.7	-	-	-	-	-	-	-	-	-	-	-
	67	151.3	17.17	145.5	130.4	115.2	100.1	84.9	69.7	54.6	-	-	-	-	-	-	-	-	-
	62	138.8	16.99	138.8	137.7	131.8	116.6	101.5	86.3	71.1	-	-	-	-	-	-	-	-	-
6000	72	142.9	17.01	142.9	141.1	134.7	119.6	104.4	89.2	74.1	-	-	-	-	-	-	-	-	-
	67	171.0	17.38	126.4	108.9	91.4	73.9	56.5	-	-	-	-	-	-	-	-	-	-	-
	62	155.2	17.16	155.2	142.8	125.3	107.8	90.3	72.8	55.3	-	-	-	-	-	-	-	-	-
	57	146.6	17.00	146.6	146.6	146.6	129.1	111.6	94.1	76.6	-	-	-	-	-	-	-	-	-
6600	72	175.0	17.50	136.4	116.9	97.4	77.9	58.5	-	-	-	-	-	-	-	-	-	-	-
	67	158.8	17.27	158.8	153.0	133.5	114.0	94.5	75.0	55.6	-	-	-	-	-	-	-	-	-
	62	145.6	17.10	145.6	145.6	145.6	126.7	107.2	87.7	68.2	-	-	-	-	-	-	-	-	-
	57	150.0	17.12	150.0	150.0	150.0	130.5	111.0	91.5	72.0	-	-	-	-	-	-	-	-	-
7200	72	179.0	17.62	146.3	124.9	103.4	81.9	60.5	-	-	-	-	-	-	-	-	-	-	-
	67	162.4	17.38	162.4	162.4	141.7	120.2	98.7	77.3	55.8	-	-	-	-	-	-	-	-	-
	62	148.9	17.21	148.9	148.9	148.9	127.5	106.0	84.5	63.1	-	-	-	-	-	-	-	-	-
	57	153.4	17.23	153.4	153.4	153.4	131.9	110.4	89.0	67.5	-	-	-	-	-	-	-	-	-

1. The capacities are gross ratings. For net capacity, deduct air blower motor, MBh = 3.415 x kW. Refer to the appropriate Blower Performance table for the kW of the supply air blower motor.

2. These ratings include the condenser fan motors (total 1 kW) and the compressor motors but not the supply air blower motor.

**TABLE 5: COOLING CAPACITIES FOR J18DJ**

Air on Evaporator Coil		Temperature of Air on Condenser Coil																			
		85°F								95°F											
		CFM	WB (°F)	Total Cap. <sup>1</sup> (MBH)	Total <sup>2</sup> Input (kW)	Sensible Capacity (MBH) <sup>+</sup> Return Dry Bulb (°F)								Total Cap. <sup>1</sup> (MBH)	Total <sup>2</sup> Input (kW)	Sensible Capacity (MBH) <sup>+</sup> Return Dry Bulb (°F)					
86	83					80	77	74	71	68	86	83	80			77	74	71	68		
6000	72	238.9	14.24	142.6	125.5	108.4	91.3	74.2	-	-	222.9	15.81	136.5	119.4	102.3	85.2	68.1	-	-		
	67	221.2	13.83	178.6	161.5	144.4	127.3	110.2	93.1	76.0	207.1	15.38	172.8	155.7	138.6	121.5	104.4	87.2	70.1		
	62	207.4	13.57	207.4	192.8	175.7	158.5	141.4	124.3	107.2	197.6	15.09	197.6	181.0	163.8	146.7	129.6	112.5	95.4		
	57	197.6	13.52	197.6	195.7	178.6	161.4	144.3	127.2	110.1	186.0	15.06	186.0	181.8	164.7	147.6	130.5	113.4	96.3		
6500	72	246.1	14.36	154.5	135.8	117.0	98.3	79.5	-	-	231.8	15.91	149.7	130.9	112.2	93.4	74.6	-	-		
	67	227.9	13.95	193.5	174.7	156.0	137.2	118.4	99.7	80.9	215.4	15.48	189.4	170.7	151.9	133.2	114.4	95.6	76.9		
	62	213.7	13.69	213.7	206.4	189.7	170.9	152.2	133.4	114.6	205.5	15.19	205.5	197.1	179.6	160.9	142.1	123.4	104.6		
	57	203.6	13.64	203.6	202.6	192.8	174.1	155.3	136.5	117.8	193.5	15.15	193.5	191.3	180.6	161.8	143.1	124.3	105.5		
7000	72	253.4	14.48	166.5	146.1	125.7	105.3	84.9	-	-	240.7	16.00	162.8	142.4	122.0	101.6	81.2	-	-		
	67	234.6	14.06	208.3	187.9	167.5	147.1	126.7	106.3	85.9	223.6	15.57	206.1	189.7	175.5	154.8	124.4	104.0	83.6		
	62	220.0	13.80	220.0	220.0	203.7	183.3	162.9	142.5	122.1	213.3	15.28	213.3	213.3	195.4	175.0	154.6	134.2	113.8		
	57	209.6	13.75	209.6	209.6	207.1	186.7	166.2	145.8	125.4	200.9	15.24	200.9	200.9	196.4	176.0	155.6	135.2	114.8		
7875	72	258.4	14.56	180.9	157.6	134.4	111.2	87.9	-	-	243.3	16.09	176.8	153.6	130.3	107.1	83.8	-	-		
	67	239.3	14.14	225.6	202.4	179.1	155.9	132.6	109.4	86.1	226.0	15.65	217.3	199.8	176.5	153.3	130.0	106.8	83.5		
	62	224.4	13.88	224.4	224.4	216.2	193.0	169.7	146.5	123.2	215.6	15.36	215.6	215.6	206.7	183.4	160.2	136.9	113.7		
	57	213.8	13.82	213.8	213.8	212.5	189.2	166.0	142.8	119.5	203.0	15.32	203.0	203.0	200.8	177.6	154.3	131.1	107.8		
8750	72	263.5	14.63	195.3	169.2	143.1	117.0	91.0	-	-	245.9	16.17	190.8	164.7	138.7	112.6	86.5	-	-		
	67	243.9	14.21	242.9	216.8	190.7	164.7	138.6	112.5	86.4	228.4	15.73	228.4	213.9	187.8	161.7	135.6	109.5	83.5		
	62	228.7	13.95	228.7	228.7	228.7	202.6	176.6	150.5	124.4	217.9	15.43	217.9	217.9	217.9	191.8	165.8	139.7	113.6		
	57	217.9	13.90	217.9	217.9	217.9	191.8	165.8	139.7	113.6	205.2	15.40	205.2	205.2	205.2	179.1	153.0	126.9	100.9		
6000	72	210.2	17.65	131.0	113.9	96.8	79.7	62.6	-	-	197.6	19.49	125.5	108.3	91.2	74.1	57.0	-	-		
	67	195.1	17.21	167.5	150.4	133.3	116.2	99.1	82.0	64.9	183.1	19.04	162.2	145.1	128.0	110.9	93.8	76.7	59.6		
	62	186.9	17.01	186.9	170.6	153.5	136.4	119.3	102.2	85.1	176.3	18.92	176.3	160.2	143.1	126.0	108.9	91.8	74.7		
	57	174.4	16.80	174.4	172.3	155.2	138.1	121.0	103.9	86.8	162.8	18.55	162.8	162.8	145.7	128.6	111.5	94.4	77.3		
6500	72	218.3	17.77	143.8	125.0	106.3	87.5	68.7	-	-	204.8	19.63	137.9	119.1	100.3	81.6	62.8	-	-		
	67	202.6	17.33	183.9	165.1	146.4	127.6	108.8	90.1	71.3	189.9	19.18	178.3	159.5	140.8	122.0	103.3	84.5	65.8		
	62	194.1	17.12	194.1	186.0	168.5	149.8	131.0	112.2	93.5	182.8	19.06	182.8	174.8	157.4	138.6	119.9	101.1	82.4		
	57	181.1	16.92	181.1	180.1	170.4	151.7	132.9	114.1	95.4	168.8	18.69	168.8	168.8	160.3	141.5	122.8	104.0	85.2		
7000	72	226.4	17.89	156.6	136.2	115.7	95.3	74.9	-	-	212.1	19.77	150.3	129.9	109.5	89.0	68.6	-	-		
	67	210.1	17.45	200.2	179.8	159.4	139.0	118.6	98.2	77.8	196.6	19.32	194.4	174.0	153.6	133.2	112.7	92.3	71.9		
	62	201.3	17.24	201.3	201.3	183.6	163.1	142.7	122.3	101.9	189.3	19.20	189.3	189.3	171.7	151.3	130.9	110.5	90.0		
	57	187.8	17.03	187.8	187.8	185.6	165.2	144.8	124.4	104.0	174.8	18.82	174.8	174.8	174.8	154.4	134.0	113.6	93.2		
7875	72	228.5	17.97	171.3	148.0	124.8	101.5	78.3	-	-	213.7	19.85	165.7	142.5	119.2	96.0	72.7	-	-		
	67	212.1	17.53	207.1	193.3	171.9	148.6	125.4	102.2	78.9	198.1	19.40	197.0	186.8	167.3	144.0	120.8	97.5	74.3		
	62	203.2	17.32	203.2	203.2	194.3	171.0	147.8	124.5	101.3	190.7	19.28	190.7	190.7	181.9	158.6	135.4	112.1	88.9		
	57	189.6	17.11	189.6	189.6	188.5	165.2	142.0	118.7	95.5	176.1	18.90	176.1	176.1	176.1	152.9	129.6	106.4	83.1		
8750	72	230.6	18.05	186.0	159.9	133.8	107.7	81.7	-	-	215.2	19.94	181.1	155.1	129.0	102.9	76.8	-	-		
	67	214.0	17.61	214.0	206.7	184.4	158.3	132.2	106.1	80.0	199.5	19.48	199.5	199.5	181.0	154.9	128.8	102.7	76.6		
	62	205.0	17.40	205.0	205.0	205.0	178.9	152.8	126.8	100.7	192.1	19.36	192.1	192.1	192.1	166.0	139.9	113.8	87.8		
	57	191.3	17.19	191.3	191.3	191.3	165.2	139.1	113.0	87.0	177.4	18.98	177.4	177.4	177.4	151.3	125.2	99.1	73.1		
6000	72	184.9	21.33	119.9	102.8	85.7	68.6	51.5	-	-	-	-	-	-	-	-	-	-	-		
	67	171.1	20.87	156.9	139.8	122.7	105.6	88.5	71.4	54.3	-	-	-	-	-	-	-	-	-		
	62	165.7	20.84	165.7	149.9	132.7	115.6	98.5	81.4	64.3	-	-	-	-	-	-	-	-	-		
	57	151.2	20.30	151.2	151.2	136.2	119.1	102.0	84.9	67.8	-	-	-	-	-	-	-	-	-		
6500	72	191.4	21.49	132.0	113.2	94.4	75.7	56.9	-	-	-	-	-	-	-	-	-	-	-		
	67	177.1	21.03	172.7	154.0	135.2	116.5	97.7	79.0	60.2	-	-	-	-	-	-	-	-	-		
	62	171.5	21.00	171.5	163.6	146.3	127.5	108.8	90.0	71.3	-	-	-	-	-	-	-	-	-		
	57	156.5	20.46	156.5	156.5	150.1	131.4	112.6	93.8	75.1	-	-	-	-	-	-	-	-	-		
7000	72	197.8	21.65	144.0	123.6	103.2	82.8	62.3	-	-	-	-	-	-	-	-	-	-	-		
	67	183.1	21.19	183.1	168.1	147.7	127.3	106.9	86.5	66.1	-	-	-	-	-	-	-	-	-		
	62	177.3	21.16	177.3	177.3	159.8	139.4	119.0	98.6	78.2	-	-	-	-	-	-	-	-	-		
	57	161.8	20.61	161.8	161.8	161.8	143.6	123.2	102.8	82.4	-	-	-	-	-	-	-	-	-		
7875	72	198.9	21.74	160.2	136.9	113.7	90.4	67.2	-	-	-	-	-	-	-	-	-	-	-		
	67	184.1	21.27	184.1	180.2	162.6	139.4	116.2	92.9	69.7	-	-	-	-	-	-	-	-	-		
	62	178.2	21.24	178.2	178.2	169.5	146.3	123.0	99.8	76.5	-	-	-	-	-	-	-	-	-		
	57	162.6	20.69	162.6	162.6	162.6	140.5	117.3	94.0	70.8	-	-	-	-	-	-	-	-	-		
8750	72	199.9	21.82	176.3	150.2	124.2	98.1	72.0	-	-	-	-	-	-	-	-	-	-	-		
	67	185.1	21.35	185.1	185.1	177.6	151.5	125.4	99.3	73.2	-	-	-	-	-	-	-	-	-		
	62	179.2	21.32	179.2	179.2	179.2	153.1	127.0	100.9	74.8	-	-	-	-	-	-	-	-	-		
	57	163.5	20.77	163.5	163.5	163.5	137.4	111.3	85.2	59.2	-	-	-	-	-	-	-	-	-		

1. The capacities are gross ratings. For net capacity, deduct air blower motor, MBh = 3.415 x kW. Refer to the appropriate Blower Performance table for the kW of the supply air blower motor.  
 2. These ratings include the condenser fan motors (total 1 kW) and the compressor motors but not the supply air blower motor.

**TABLE 6: COOLING CAPACITIES FOR J20DJ**

Air on Evaporator Coil		Temperature of Air on Condenser Coil																	
CFM	WB (°F)	85°F								95°F									
		Total Cap. <sup>1</sup> (MBH)	Total <sup>2</sup> Input (kW)	Sensible Capacity (MBH) <sup>*</sup> Return Dry Bulb (°F)						Total Cap. <sup>1</sup> (MBH)	Total <sup>2</sup> Input (kW)	Sensible Capacity (MBH) <sup>*</sup> Return Dry Bulb (°F)							
				86	83	80	77	74	71			68	86	83	80	77	74	71	68
6000	72	273.1	16.90	149.8	132.7	115.6	98.5	81.4	-	-	257.3	18.45	150.2	133.1	116.0	98.9	81.8	-	-
	67	248.6	16.43	197.6	180.5	163.4	146.3	129.1	112.0	94.9	237.3	17.83	192.3	175.1	158.0	140.9	123.8	106.7	89.6
	62	231.2	16.44	227.9	210.8	193.7	176.6	159.5	142.4	125.3	215.2	17.64	215.2	200.8	183.7	166.6	149.5	132.4	115.3
	57	216.6	15.98	216.6	210.2	193.1	176.0	158.9	141.8	124.7	221.2	17.98	221.2	213.2	196.1	179.0	161.8	144.7	127.6
7000	72	278.7	16.96	165.8	145.6	125.4	105.1	84.9	-	-	264.7	18.51	167.2	146.9	126.7	106.5	86.3	-	-
	67	253.8	16.49	217.5	197.3	177.1	156.9	136.7	116.5	96.2	244.2	17.89	213.1	192.9	172.7	152.4	132.2	112.0	91.8
	62	236.0	16.50	234.4	225.8	210.0	189.8	169.6	149.4	129.2	221.5	17.70	221.5	214.3	200.7	180.5	160.3	140.0	119.8
	57	221.1	16.04	221.1	217.9	209.3	189.1	168.9	148.7	128.5	227.6	18.04	227.6	223.6	214.2	194.0	173.8	153.5	133.3
8000	72	284.4	17.02	181.8	158.4	135.1	111.8	88.4	-	-	272.2	18.58	184.1	160.8	137.4	114.1	90.8	-	-
	67	259.0	16.55	237.5	214.2	190.9	167.5	144.2	120.9	97.6	251.0	17.95	233.9	210.6	187.3	164.0	140.6	117.3	94.0
	62	240.8	16.56	240.8	240.8	226.3	203.0	179.7	156.4	133.0	227.7	17.76	227.7	227.7	217.7	194.4	171.0	147.7	124.4
	57	225.6	16.10	225.6	225.6	225.6	202.3	178.9	155.6	132.3	234.0	18.10	234.0	234.0	232.3	209.0	185.7	162.4	139.0
8700	72	291.0	17.43	193.1	167.5	141.8	116.1	90.4	-	-	277.5	18.98	195.6	169.9	144.2	118.5	92.9	-	-
	67	265.0	16.95	251.7	226.0	200.3	174.7	149.0	123.3	97.6	256.0	18.33	247.4	222.2	196.5	170.8	145.2	119.5	93.8
	62	246.4	16.96	246.4	246.4	237.6	211.9	186.2	160.5	134.9	232.2	18.14	232.2	232.2	227.2	201.5	175.8	150.1	124.5
	57	230.8	16.49	230.8	230.8	230.8	205.2	179.5	153.8	128.1	238.6	18.50	238.6	238.6	237.7	212.1	186.4	160.7	135.0
9400	72	297.7	17.84	204.5	176.5	148.5	120.5	92.4	-	-	282.9	19.38	207.0	179.0	151.0	123.0	94.9	-	-
	67	271.0	17.35	265.8	237.8	209.8	181.8	153.7	125.7	97.7	260.9	18.72	260.9	233.7	205.7	177.7	149.7	121.7	93.6
	62	252.0	17.36	252.0	252.0	248.8	220.7	192.7	164.7	136.7	236.6	18.53	236.6	236.6	236.6	208.6	180.6	152.6	124.6
	57	236.1	16.88	236.1	236.1	236.1	208.1	180.1	152.0	124.0	243.2	18.89	243.2	243.2	243.2	215.1	187.1	159.1	131.1
6000	72	244.1	20.09	146.5	129.4	112.3	95.2	78.1	-	-	230.8	21.72	142.8	125.7	108.6	91.5	74.4	-	-
	67	225.3	19.63	186.7	169.6	152.5	135.4	118.3	101.2	84.1	213.4	21.43	181.2	164.1	147.0	129.9	112.8	95.7	78.6
	62	202.7	19.37	202.7	194.9	177.7	160.6	143.5	126.4	109.3	190.2	21.09	190.2	188.9	171.8	154.7	137.6	120.5	103.4
	57	211.7	19.63	211.7	205.7	188.6	171.5	154.4	137.3	120.2	202.2	21.28	202.2	198.2	181.1	164.0	146.9	129.8	112.7
7000	72	250.6	20.15	162.5	142.2	122.0	101.8	81.6	-	-	236.4	21.79	157.8	137.5	117.3	97.1	76.9	-	-
	67	231.3	19.69	206.2	185.9	165.7	145.5	125.3	105.1	84.9	218.5	21.50	199.2	179.0	158.8	138.6	118.4	98.1	77.9
	62	208.1	19.43	208.1	204.2	193.1	172.9	152.7	132.5	112.3	194.8	21.16	194.8	194.1	185.6	165.4	145.1	124.9	104.7
	57	217.3	19.70	217.3	214.3	204.9	184.7	164.5	144.3	124.1	207.0	21.35	207.0	205.1	195.7	175.4	155.2	135.0	114.8
8000	72	257.0	20.22	178.4	155.1	131.7	108.4	85.1	-	-	241.9	21.87	172.7	149.4	126.0	102.7	79.4	-	-
	67	237.3	19.76	225.6	202.3	178.9	155.6	132.3	109.0	85.6	223.6	21.58	217.3	193.9	170.6	147.3	123.9	100.6	77.3
	62	213.5	19.50	213.5	213.5	208.5	185.2	161.9	138.5	115.2	199.4	21.24	199.4	199.4	199.4	176.0	152.7	129.4	106.1
	57	222.9	19.77	222.9	222.9	221.3	197.9	174.6	151.3	128.0	211.9	21.43	211.9	211.9	210.2	186.9	163.5	140.2	116.9
8700	72	264.1	20.56	191.3	165.6	139.9	114.3	88.6	-	-	250.6	22.15	187.0	161.3	135.6	110.0	84.3	-	-
	67	243.8	20.09	238.0	215.7	190.0	164.4	138.7	113.0	87.3	231.7	21.85	228.5	209.3	183.6	157.9	132.2	106.6	80.9
	62	219.4	19.83	219.4	219.4	216.9	191.2	165.5	139.8	114.2	206.6	21.51	206.6	206.6	206.6	180.9	155.2	129.5	103.9
	57	229.0	20.10	229.0	229.0	228.2	202.5	176.9	151.2	125.5	219.5	21.70	219.5	219.5	218.7	193.0	167.3	141.7	116.0
9400	72	271.1	20.91	204.1	176.1	148.1	120.1	92.1	-	-	259.4	22.43	201.3	173.3	145.2	117.2	89.2	-	-
	67	250.3	20.43	250.3	229.2	201.1	173.1	145.1	117.1	89.1	239.7	22.13	239.7	224.6	196.6	168.6	140.5	112.5	84.5
	62	225.2	20.16	225.2	225.2	225.2	197.2	169.2	141.1	113.1	213.8	21.78	213.8	213.8	213.8	185.7	157.7	129.7	101.7
	57	235.2	20.43	235.2	235.2	235.2	207.1	179.1	151.1	123.1	227.2	21.98	227.2	227.2	227.2	199.2	171.1	143.1	115.1
6000	72	217.6	23.35	139.1	122.0	104.9	87.8	70.7	-	-	-	-	-	-	-	-	-	-	-
	67	201.4	23.23	175.7	158.6	141.5	124.4	107.3	90.2	73.1	-	-	-	-	-	-	-	-	-
	62	177.7	22.82	177.7	177.7	165.8	148.7	131.6	114.5	97.4	-	-	-	-	-	-	-	-	-
	57	192.7	22.93	192.7	190.8	173.7	156.5	139.4	122.3	105.2	-	-	-	-	-	-	-	-	-
7000	72	222.2	23.43	153.1	132.8	112.6	92.4	72.2	-	-	-	-	-	-	-	-	-	-	-
	67	205.6	23.31	192.3	172.1	151.9	131.7	111.4	91.2	71.0	-	-	-	-	-	-	-	-	-
	62	181.5	22.90	181.5	181.5	178.0	157.8	137.6	117.4	97.1	-	-	-	-	-	-	-	-	-
	57	196.8	23.01	196.8	195.8	186.4	166.2	146.0	125.7	105.5	-	-	-	-	-	-	-	-	-
8000	72	226.8	23.51	167.0	143.7	120.3	97.0	73.7	-	-	-	-	-	-	-	-	-	-	-
	67	209.9	23.39	208.9	185.6	162.3	138.9	115.6	92.3	68.9	-	-	-	-	-	-	-	-	-
	62	185.2	22.98	185.2	185.2	185.2	166.9	143.5	120.2	96.9	-	-	-	-	-	-	-	-	-
	57	200.8	23.09	200.8	200.8	199.1	175.8	152.5	129.1	105.8	-	-	-	-	-	-	-	-	-
8700	72	237.2	23.74	182.7	157.0	131.3	105.7	80.0	-	-	-	-	-	-	-	-	-	-	-
	67	219.5	23.61	219.0	202.8	177.1	151.5	125.8	100.1	74.4	-	-	-	-	-	-	-	-	-
	62	193.7	23.19	193.7	193.7	193.7	170.6	144.9	119.2	93.6	-	-	-	-	-	-	-	-	-
	57	210.0	23.30	210.0	210.0	209.2	183.5	157.8	132.1	106.5	-	-	-	-	-	-	-	-	-
9400	72	247.6	23.96	198.4	170.4	142.4	114.3	86.3	-	-	-	-	-	-	-	-	-	-	-
	67	229.1	23.84	229.1	220.0	192.0	164.0	136.0	107.9	79.9	-	-	-	-	-	-	-	-	-
	62	202.3	23.41	202.3	202.3	202.3	174.3	146.3	118.2	90.2	-	-	-	-	-	-	-	-	-
	57	219.2	23.52	219.2	219.2	219.2	191.2	163.2	135.1	107.1	-	-	-	-	-	-	-	-	-

1. The capacities are gross ratings. For net capacity, deduct air blower motor, MBh = 3.415 x kW. Refer to the appropriate Blower Performance table for the kW of the supply air blower motor.  
 2. These ratings include the condenser fan motors (total 1 kW) and the compressor motors but not the supply air blower motor.

**TABLE 7: COOLING CAPACITIES FOR J25DJ**

Air on Evaporator Coil		Temperature of Air on Condenser Coil																	
		85°F										95°F							
		CFM	WB (°F)	Total Cap. <sup>1</sup> (MBH)	Total <sup>2</sup> Input (kW)	Sensible Capacity (MBH) <sup>1</sup> Return Dry Bulb (°F)								Total Cap. <sup>1</sup> (MBH)	Total <sup>2</sup> Input (kW)	Sensible Capacity (MBH) <sup>1</sup> Return Dry Bulb (°F)			
86	83					80	77	74	71	68	86	83	80			77	74	71	68
7500	72	332.2	21.58	206.4	185.0	163.6	142.3	120.9	-	-	324.4	25.42	191.5	170.2	148.8	127.4	106.0	-	-
	67	327.2	21.26	256.1	234.7	213.3	192.0	170.6	149.2	127.8	305.5	24.73	245.9	224.5	203.1	181.7	160.4	139.0	117.6
	62	321.0	20.60	320.3	298.9	277.5	256.1	234.7	213.4	192.0	301.1	24.23	295.5	274.2	252.8	231.4	210.0	188.6	167.2
	57	313.6	20.57	313.6	305.9	284.5	263.1	241.8	220.4	199.0	292.2	24.07	292.2	277.1	255.7	234.3	212.9	191.5	170.1
8750	72	329.6	22.39	217.2	191.9	166.6	141.4	116.1	-	-	326.8	25.46	207.5	182.3	157.0	131.7	106.4	-	-
	67	324.6	22.06	267.8	242.5	217.3	192.0	166.7	141.4	116.2	307.7	24.76	264.9	239.6	214.4	189.1	163.8	138.5	113.3
	62	318.4	21.37	318.0	307.3	282.6	257.3	232.0	206.8	181.5	303.3	24.26	300.5	289.8	266.7	241.5	216.2	190.9	165.7
	57	311.1	21.34	311.1	307.2	289.7	264.5	239.2	213.9	188.6	294.3	24.10	294.3	286.7	269.8	244.5	219.3	194.0	168.7
10000	72	326.9	23.20	228.0	198.8	169.6	140.5	111.3	-	-	329.1	25.49	223.5	194.4	165.2	136.1	106.9	-	-
	67	321.9	22.86	279.5	250.3	221.2	192.0	162.8	133.7	104.5	309.9	24.79	283.9	254.7	225.6	196.4	167.3	138.1	108.9
	62	315.8	22.15	315.8	315.8	287.7	258.5	229.4	200.2	171.0	305.5	24.29	305.5	305.5	280.7	251.6	222.4	193.2	164.1
	57	308.5	22.12	308.5	308.5	294.9	265.8	236.6	207.5	178.3	296.4	24.13	296.4	296.4	283.9	254.8	225.6	196.5	167.3
11250	72	333.6	23.42	241.2	208.0	174.8	141.6	108.4	-	-	336.1	25.73	238.9	205.7	172.5	139.3	106.1	-	-
	67	328.6	23.07	294.3	261.1	227.9	194.7	161.5	128.3	95.1	316.4	25.02	302.0	269.8	235.6	198.2	163.9	135.9	102.7
	62	322.3	22.35	322.3	322.3	296.5	263.3	230.0	196.8	163.6	311.9	24.52	311.9	311.9	293.1	259.9	226.7	193.5	160.3
	57	314.9	22.32	314.9	314.9	304.0	270.7	237.5	204.3	171.1	302.7	24.36	302.7	302.7	296.5	263.2	230.0	196.8	163.6
12500	72	340.4	23.63	254.5	217.3	180.0	142.7	105.5	-	-	343.1	25.96	254.3	217.1	179.8	142.5	105.3	-	-
	67	335.2	23.28	309.2	271.9	234.7	197.4	160.2	122.9	85.6	323.0	25.25	320.0	282.8	245.5	198.2	171.0	133.7	96.5
	62	328.8	22.55	328.8	328.8	305.2	268.0	230.7	193.5	156.2	318.4	24.74	318.4	318.4	305.5	268.2	231.0	193.7	156.5
	57	321.3	22.53	321.3	321.3	313.0	275.7	238.4	201.2	163.9	309.0	24.58	309.0	309.0	309.0	271.7	234.4	197.2	159.9
		105°F										115°F							
7500	72	301.8	27.73	184.5	163.2	141.8	120.4	99.0	-	-	279.1	30.03	177.6	156.2	134.8	113.4	92.0	-	-
	67	289.0	27.27	238.8	217.4	196.0	174.6	153.2	131.9	110.5	272.6	29.81	231.6	210.3	188.9	167.5	146.1	124.7	103.3
	62	283.6	26.57	280.8	259.7	238.3	216.9	195.5	174.1	152.7	266.0	28.91	266.0	245.2	223.8	202.4	181.0	159.6	138.3
	57	271.5	26.43	271.5	260.3	238.9	217.6	196.2	174.8	153.4	250.9	28.79	250.9	243.6	222.2	200.8	179.4	158.1	136.7
8750	72	306.8	27.83	201.3	176.1	150.8	125.5	100.2	-	-	286.9	30.20	195.1	169.8	144.6	119.3	94.0	-	-
	67	293.9	27.37	259.0	233.7	208.5	183.2	157.9	132.7	107.4	280.1	29.98	253.1	227.9	202.6	177.3	152.0	126.8	101.5
	62	288.3	26.67	286.9	276.4	253.4	228.1	202.8	177.6	152.3	273.3	29.07	273.3	262.9	240.0	214.8	189.5	164.2	138.9
	57	276.1	26.53	276.1	270.5	254.1	228.8	203.5	178.3	153.0	257.9	28.96	257.9	254.2	238.3	213.1	187.8	162.5	137.3
10000	72	311.8	27.93	218.1	188.9	159.8	130.6	101.5	-	-	294.6	30.38	212.7	183.5	154.4	125.2	96.0	-	-
	67	298.7	27.47	279.3	250.1	220.9	191.8	162.6	133.5	104.3	287.6	30.16	274.6	245.5	216.3	187.1	158.0	128.8	99.7
	62	293.1	26.77	293.1	293.1	268.5	239.3	210.2	181.0	151.9	280.7	29.24	280.7	280.7	256.3	227.1	198.0	168.8	139.6
	57	280.6	26.63	280.6	280.6	269.2	240.0	210.9	181.7	152.6	264.8	29.13	264.8	264.8	254.5	225.3	196.2	167.0	137.8
11250	72	318.7	28.19	233.1	199.9	166.7	133.5	100.3	-	-	301.4	30.66	227.3	194.1	160.9	127.7	94.5	-	-
	67	305.4	27.73	294.9	263.7	230.5	197.3	164.1	130.9	97.7	294.3	30.44	287.8	258.7	225.5	192.3	159.1	125.9	92.7
	62	299.6	27.02	299.6	299.6	280.1	246.9	213.7	180.5	147.3	287.2	29.52	287.2	287.2	267.2	234.0	200.8	167.6	134.3
	57	286.8	26.88	286.8	286.8	280.9	247.7	214.5	181.2	148.0	270.9	29.40	270.9	270.9	265.3	232.1	198.9	165.7	132.5
12500	72	325.6	28.46	248.2	210.9	173.6	136.4	99.1	-	-	308.2	30.95	242.0	204.8	167.5	130.2	93.0	-	-
	67	312.0	27.99	310.5	277.4	240.1	202.8	165.6	128.3	91.1	300.9	30.72	300.9	272.0	234.7	197.4	160.2	122.9	85.7
	62	306.0	27.27	306.0	306.0	291.8	254.5	217.3	180.0	142.8	293.6	29.79	293.6	293.6	278.1	240.8	203.6	166.3	129.0
	57	293.0	27.13	293.0	293.0	292.5	255.3	218.0	180.8	143.5	277.0	29.68	277.0	277.0	276.1	238.9	201.6	164.3	127.1
		125°F																	
7500	72	256.5	32.33	170.6	149.2	127.8	106.4	85.0	-	-	-	-	-	-	-	-	-	-	-
	67	256.1	32.35	224.5	203.1	181.8	160.4	139.0	117.6	96.2	-	-	-	-	-	-	-	-	-
	62	248.4	31.25	248.4	230.7	209.3	187.9	166.5	145.2	123.8	-	-	-	-	-	-	-	-	-
	57	230.3	31.16	230.3	226.9	205.5	184.1	162.7	141.3	120.0	-	-	-	-	-	-	-	-	-
8750	72	266.9	32.57	188.9	163.6	138.4	113.1	87.8	-	-	-	-	-	-	-	-	-	-	-
	67	266.3	32.60	247.2	222.0	196.7	171.4	146.2	120.9	95.6	-	-	-	-	-	-	-	-	-
	62	258.4	31.48	258.4	249.5	226.7	201.4	176.1	150.9	125.6	-	-	-	-	-	-	-	-	-
	57	239.7	31.39	239.7	237.9	222.6	197.3	172.1	146.8	121.5	-	-	-	-	-	-	-	-	-
10000	72	277.3	32.82	207.3	178.1	148.9	119.8	90.6	-	-	-	-	-	-	-	-	-	-	-
	67	276.5	32.84	270.0	240.8	211.7	182.5	153.3	124.2	95.0	-	-	-	-	-	-	-	-	-
	62	268.3	31.71	268.3	268.3	244.1	214.9	185.7	156.6	127.4	-	-	-	-	-	-	-	-	-
	57	249.0	31.63	249.0	249.0	239.7	210.6	181.4	152.3	123.1	-	-	-	-	-	-	-	-	-
11250	72	284.0	33.13	221.6	188.3	155.1	121.9	88.7	-	-	-	-	-	-	-	-	-	-	-
	67	283.2	33.15	280.7	253.7	220.5	187.3	154.1	120.8	87.6	-	-	-	-	-	-	-	-	-
	62	274.8	32.01	274.8	274.8	254.2	221.0	187.8	154.6	121.4	-	-	-	-	-	-	-	-	-
	57	255.0	31.92	255.0	255.0	249.7	216.5	183.3	150.1	116.9	-	-	-	-	-	-	-	-	-
12500	72	290.7	33.44	235.9	198.6	161.3	124.1	86.8	-	-	-	-	-	-	-	-	-	-	-
	67	289.8	33.46	289.8	266.6	229.3	192.0	154.8	117.5	80.3	-	-	-	-	-	-	-	-	-
	62	281.3	32.32	281.3	281.3	264.4	227.1	189.9	152.6	115.3	-	-	-	-	-	-	-	-	-
	57	261.0	32.22	261.0	261.0	259.7	222.4	185.2	147.9	110.7	-	-	-	-	-	-	-	-	-

1. The capacities are gross ratings. For net capacity, deduct air blower motor, MBh = 3.415 x kW. Refer to the appropriate Blower Performance table for the kW of the supply air blower motor.  
 2. These ratings include the condenser fan motors (total 1 kW) and the compressor motors but not the supply air blower motor.

## CFM, STATIC PRESSURE, AND POWER - ALTI-TUDE AND TEMPERATURE CORRECTIONS

The information below should be used to assist in application of product when being applied at altitudes at or exceeding 1000 feet above sea level.

The air flow rates listed in the standard blower performance tables are based on standard air at sea level. As the altitude or temperature increases, the density of air decreases. In

order to use the indoor blower tables for high altitude applications, certain corrections are necessary.

A centrifugal fan is a "constant volume" device. This means that, if the rpm remains constant, the CFM delivered is the same regardless of the density of the air. However, since the air at high altitude is less dense, less static pressure will be generated and less power will be required than a similar application at sea level. Air density correction factors are shown in Table 8 and Figure 2.

**TABLE 8: ALTITUDE CORRECTION FACTORS**

AIR TEMP	ALTITUDE (FEET)										
	0	1000	2000	3000	4000	5000	6000	7000	8000	9000	10000
40	1.060	1.022	0.986	0.950	0.916	0.882	0.849	0.818	0.788	0.758	0.729
50	1.039	1.002	0.966	0.931	0.898	0.864	0.832	0.802	0.772	0.743	0.715
60	1.019	0.982	0.948	0.913	0.880	0.848	0.816	0.787	0.757	0.729	0.701
70	1.000	0.964	0.930	0.896	0.864	0.832	0.801	0.772	0.743	0.715	0.688
80	0.982	0.947	0.913	0.880	0.848	0.817	0.787	0.758	0.730	0.702	0.676
90	0.964	0.929	0.897	0.864	0.833	0.802	0.772	0.744	0.716	0.689	0.663
100	0.946	0.912	0.880	0.848	0.817	0.787	0.758	0.730	0.703	0.676	0.651

The examples below will assist in determining the airflow performance of the product at altitude.

**Example 1:** What are the corrected CFM, static pressure, and BHP at an elevation of 5,000 ft. if the blower performance data is 6,000 CFM, 1.5 IWC and 4.0 BHP?

**Solution:** At an elevation of 5,000 ft the indoor blower will still deliver 6,000 CFM if the rpm is unchanged. However, Table 8 must be used to determine the static pressure and BHP. Since no temperature data is given, we will assume an air temperature of 70°F. Table 8 shows the correction factor to be 0.832.

$$\text{Corrected static pressure} = 1.5 \times 0.832 = 1.248 \text{ IWC}$$

$$\text{Corrected BHP} = 4.0 \times 0.832 = 3.328$$

**Example 2:** A system, located at 5,000 feet of elevation, is to deliver 6,000 CFM at a static pressure of 1.5". Use the unit

blower tables to select the blower speed and the BHP requirement.

**Solution:** As in the example above, no temperature information is given so 70°F is assumed.

The 1.5" static pressure given is at an elevation of 5,000 ft. The first step is to convert this static pressure to equivalent sea level conditions.

$$\text{Sea level static pressure} = 1.5 / .832 = 1.80"$$

Enter the blower table at 6000 sCFM and static pressure of 1.8". The rpm listed will be the same rpm needed at 5,000 ft.

Suppose that the corresponding BHP listed in the table is 3.2. This value must be corrected for elevation.

$$\text{BHP at 5,000 ft} = 3.2 \times .832 = 2.66$$

# Altitude/Temperature Conversion Factor

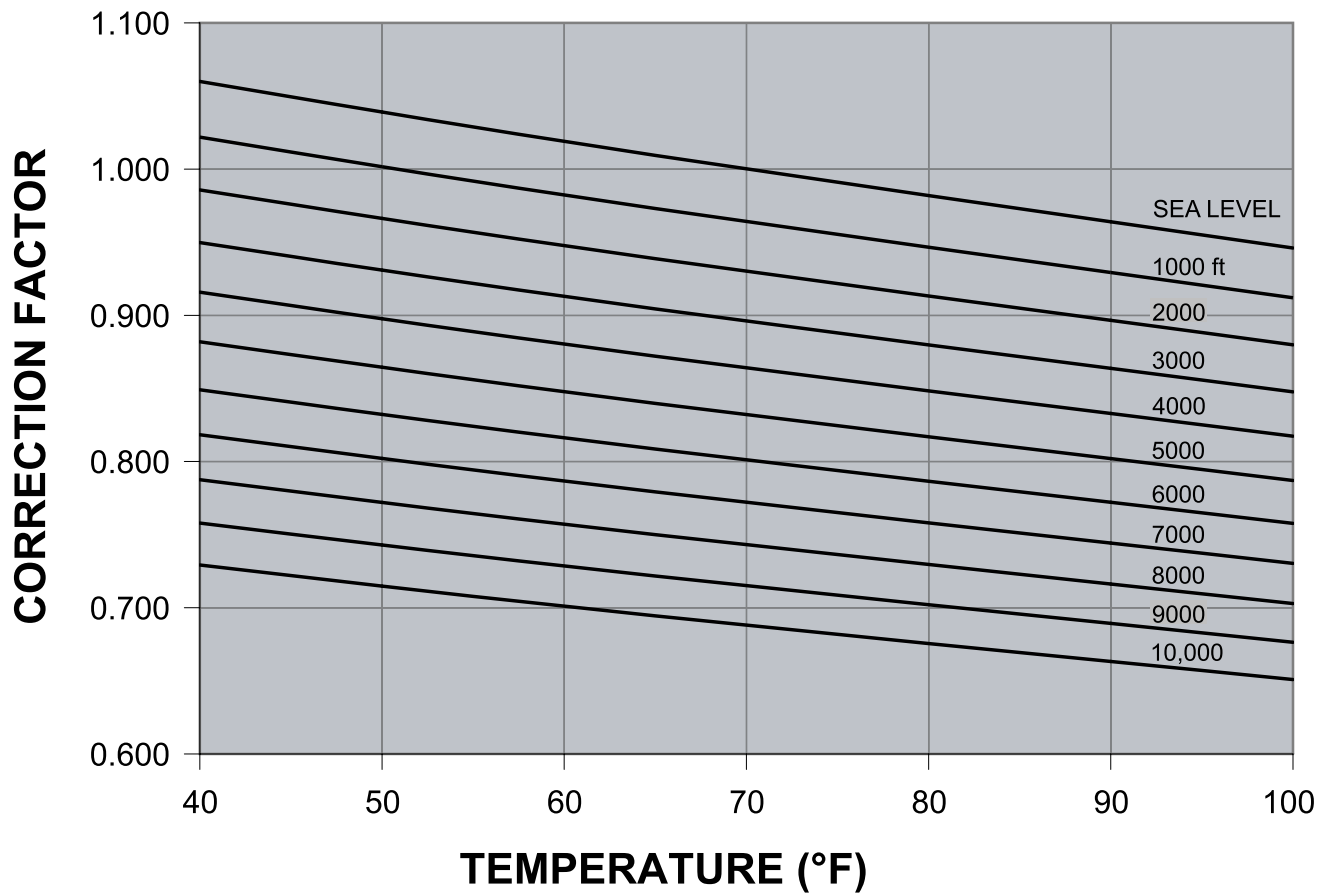


FIGURE 2 - ALTITUDE/TEMPERATURE CONVERSION FACTOR

**TABLE 9: SUPPLY AIR BLOWER PERFORMANCE (15 TON) - COOLING ONLY  
180 MBH - BOTTOM DUCT CONNECTIONS**

BLOWER SPEED, (RPM)	MOTOR PULLEY (TURNS OPEN)*	CFM														
		4500			5250			6000			6750			7200		
		ESP	BHP	KW	ESP	BHP	KW	ESP	BHP	KW	ESP	BHP	KW	ESP	BHP	KW
<b>208 VOLT AND STANDARD DRIVE</b>																
850	6.0**	0.9	2.4	2.2	0.7	3.0	2.7	0.5	3.2	2.9	-	-	-	-	-	-
870	5.5	1.0	2.5	2.3	0.8	3.1	2.8	0.6	3.5	3.1	0.2	4.1	3.7	-	-	-
915	4.5	1.1	2.6	2.4	0.9	3.4	3.0	0.7	3.7	3.3	0.3	4.4	3.9	0.2	4.5	4.0
965	3.5	1.2	2.9	2.6	1.0	3.6	3.2	0.8	4.0	3.6	0.5	4.7	4.2	0.4	4.9	4.4
980	3.0	1.3	3.0	2.7	1.1	3.7	3.3	0.9	4.1	3.7	0.6	4.8	4.3	0.5	5.1	4.6
1010	2.0	1.4	3.1	2.8	1.2	3.8	3.4	1.0	4.2	3.8	0.7	5.0	4.5	0.6	5.4	4.8
1040	1.0	1.5	3.2	2.9	1.3	3.9	3.5	1.1	4.5	4.0	0.9	5.2	4.7	0.7	5.7	5.1
<b>208 VOLT AND HIGH STATIC DRIVE</b>																
965	6.0	1.2	2.9	2.6	1.0	3.6	3.2	0.8	4.0	3.6	0.5	4.7	4.2	0.4	5.0	4.4
980	5.5	1.3	3.0	2.7	1.1	3.7	3.3	0.9	4.1	3.7	0.6	4.8	4.3	0.5	5.1	4.6
1025	4.5	1.5	3.2	2.9	1.3	3.9	3.5	1.1	4.5	4.0	0.8	5.1	4.6	0.7	5.6	5.0
1065	3.5	1.6	3.4	3.0	1.4	4.0	3.6	1.2	4.7	4.2	1.0	5.5	4.9	-	-	-
1095	3.0	1.7	3.5	3.1	1.5	4.2	3.8	1.3	4.9	4.4	1.2	5.7	5.1	-	-	-
1130	2.0	1.9	3.7	3.3	1.7	4.5	4.0	1.5	5.1	4.6	-	-	-	-	-	-
1170	1.0	2.1	3.9	3.5	2.0	4.7	4.2	1.8	5.5	4.9	-	-	-	-	-	-
<b>230/460/575 VOLT AND STANDARD DRIVE</b>																
870	6.0**	1.0	2.4	2.2	0.8	3.1	2.8	0.6	3.5	3.1	0.2	4.1	3.7	-	-	-
915	5.0	1.1	2.6	2.4	0.9	3.3	3.0	0.7	3.7	3.3	0.3	4.4	3.9	0.2	4.5	4.0
965	4.0	1.2	2.9	2.6	1.0	3.6	3.2	0.8	4.0	3.6	0.5	4.7	4.2	0.4	5.0	4.4
980	3.5	1.3	3.0	2.7	1.1	3.7	3.3	0.9	4.1	3.7	0.6	4.8	4.3	0.5	5.1	4.6
1040	2.0	1.5	3.2	2.9	1.3	3.9	3.5	1.1	4.5	4.0	0.9	5.3	4.7	0.7	5.7	5.1
1065	1.0	1.6	3.3	3.0	1.4	4.0	3.6	1.2	4.7	4.2	1.0	5.5	4.9	-	-	-
<b>230/460/575 VOLT AND HIGH STATIC DRIVE</b>																
980	6.0	1.3	2.9	2.6	1.1	3.7	3.3	0.9	4.1	3.7	0.6	4.8	4.3	0.5	5.1	4.6
1040	4.5	1.5	3.2	2.9	1.3	3.9	3.5	1.1	4.5	4.0	0.9	5.3	4.7	0.7	5.7	5.1
1065	4.0	1.6	3.4	3.0	1.4	4.0	3.6	1.2	4.7	4.2	1.0	5.5	4.9	-	-	-
1095	3.5	1.7	3.5	3.1	1.5	4.2	3.8	1.3	4.9	4.4	1.2	5.7	5.1	-	-	-
1130	2.5	1.9	3.7	3.3	1.7	4.5	4.0	1.5	5.1	4.6	-	-	-	-	-	-
1170	1.5	2.1	3.9	3.5	2.0	4.7	4.2	1.8	5.5	4.9	-	-	-	-	-	-
1190	1.0	2.2	4.0	3.6	2.1	4.8	4.3	2.0	5.7	5.1	-	-	-	-	-	-

NOTES: 1. Blower performance includes fixed outdoor air, 2" T/A filters, a dry evaporator coil and no electric heat.

2. Refer to Table 13 for additional static resistances.

ESP = External Static Pressure available for the supply and return air duct system. All internal unit resistances have been deducted from the total static pressure of the blower.

\* Do **NOT** close the pulley below 1 turn open.

\*\* Factory setting.



**TABLE 10: SUPPLY AIR BLOWER PERFORMANCE (17.5 TON) - COOLING ONLY  
210 MBH - BOTTOM DUCT CONNECTIONS**

BLOWER SPEED, (RPM)	MOTOR PULLEY (TURNS OPEN)*	CFM											
		6000			7000			8000			9000		
		ESP	BHP	KW	ESP	BHP	KW	ESP	BHP	KW	ESP	BHP	KW
<b>208 VOLT AND STANDARD DRIVE</b>													
870	6.0**	0.4	2.1	1.8	0.1	2.3	2.0	-	-	-	-	-	-
900	5.0	0.8	3.2	2.7	0.5	3.5	2.9	0.2	3.8	3.2	-	-	-
930	4.0	1.1	4.1	3.4	0.9	4.5	3.8	0.6	4.9	4.1	0.1	5.1	4.3
950	3.0	1.3	4.6	3.9	1.1	5.1	4.3	0.8	5.5	4.6	0.4	5.9	5.0
980	2.0	1.6	5.3	4.5	1.4	5.8	4.9	1.2	6.3	5.3	0.7	6.9	5.8
1015	1.0	1.9	5.9	5.0	1.7	6.5	5.5	1.5	7.0	5.9	1.0	7.7	6.5
<b>208 VOLT AND HIGH STATIC DRIVE</b>													
950	6.0	1.3	4.6	3.9	1.1	5.1	4.3	0.8	5.5	4.6	0.4	5.9	5.0
980	5.0	1.6	5.3	4.5	1.4	5.8	4.9	1.2	6.3	5.3	0.7	6.9	5.8
1010	4.0	1.8	5.8	4.9	1.7	6.3	5.3	1.5	6.9	5.8	1.0	7.5	6.3
1020	3.5	1.9	6.1	5.1	1.8	6.5	5.5	1.6	7.1	6.0	1.1	7.8	6.6
1035	3.0	2.0	6.2	5.2	1.9	6.8	5.7	1.7	7.4	6.2	1.2	8.1	6.8
1050	2.5	2.1	6.4	5.4	2.0	7.0	5.9	1.8	7.6	6.4	1.3	8.3	7.0
1075	2.0	2.3	6.6	5.5	2.1	7.2	6.0	1.9	7.8	6.6	1.5	8.6	7.2
1100	1.0	2.4	6.7	5.6	2.2	7.3	6.1	2.1	7.9	6.7	-	-	-
<b>230/460/575 VOLT AND STANDARD DRIVE</b>													
870	6.0**	0.4	2.1	1.8	0.1	2.3	2.0	-	-	-	-	-	-
900	5.0	0.8	3.2	2.7	0.5	3.5	2.9	0.2	3.8	3.2	-	-	-
930	4.0	1.1	4.1	3.4	0.9	4.5	3.8	0.6	4.9	4.1	0.1	5.1	4.3
950	3.5	1.3	4.6	3.9	1.1	5.1	4.3	0.8	5.5	4.6	0.4	5.9	5.0
980	2.5	1.6	5.3	4.5	1.4	5.8	4.9	1.2	6.3	5.3	0.7	6.9	5.8
1015	1.5	1.9	5.9	5.0	1.7	6.5	5.5	1.5	7.0	5.9	1.0	7.7	6.5
1025	1.0	2.0	6.1	5.1	1.8	6.6	5.6	1.6	7.3	6.1	1.1	7.9	6.7
<b>230/460/575 VOLT AND HIGH STATIC DRIVE</b>													
950	6.0	1.3	4.6	3.9	1.1	5.1	4.3	0.8	5.5	4.6	0.4	5.9	5.0
980	5.0	1.6	5.3	4.5	1.4	5.8	4.9	1.2	6.3	5.3	0.7	6.9	5.8
1015	4.0	1.9	5.9	5.0	1.7	6.5	5.5	1.5	7.0	5.9	1.0	7.7	6.5
1035	3.5	2.0	6.2	5.2	1.9	6.8	5.7	1.7	7.4	6.2	1.2	8.1	6.8
1050	3.0	2.1	6.4	5.4	2.0	7.0	5.9	1.8	7.6	6.4	1.3	8.3	7.0
1080	2.0	2.3	6.6	5.5	2.1	7.2	6.0	1.9	7.8	6.6	1.5	8.6	7.2
1100	1.5	2.4	6.7	5.6	2.2	7.3	6.1	2.1	7.9	6.7	-	-	-
1120	1.0	2.5	6.8	5.7	2.3	7.4	6.2	2.2	8.1	6.8	-	-	-

NOTES: 1. Blower performance includes fixed outdoor air, 2" T/A filters, a dry evaporator coil and no electric heat.

2. Refer to Table 13 for additional static resistances.

ESP = External Static Pressure available for the supply and return air duct system. All internal unit resistances have been deducted from the total static pressure of the blower.

\* Do **NOT** close the pulley below 1 turn open.

\*\* Factory setting.

**TABLE 11: SUPPLY AIR BLOWER PERFORMANCE (20 TON) - COOLING ONLY  
240 MBH - BOTTOM DUCT CONNECTIONS**

BLOWER SPEED, (RPM)	MOTOR PULLEY (TURNS OPEN)*	CFM														
		6000			7000			8000			9000			9400		
		ESP	BHP	KW	ESP	BHP	KW	ESP	BHP	KW	ESP	BHP	KW	ESP	BHP	KW
<b>208 VOLT AND STANDARD DRIVE</b>																
870	6.0**	0.4	2.1	1.8	0.1	2.3	2.0	-	-	-	-	-	-	-	-	-
900	5.0	0.8	3.2	2.7	0.5	3.5	2.9	0.2	3.8	3.2	-	-	-	-	-	-
930	4.0	1.1	4.1	3.4	0.9	4.5	3.8	0.6	4.9	4.1	0.1	5.1	4.3	-	-	-
950	3.0	1.3	4.6	3.9	1.1	5.1	4.3	0.8	5.5	4.6	0.4	5.9	5.0	-	-	-
980	2.0	1.6	5.3	4.5	1.4	5.8	4.9	1.2	6.3	5.3	0.7	6.9	5.8	0.2	7.3	6.1
1015	1.0	1.9	5.9	5.0	1.7	6.5	5.5	1.5	7.0	5.9	1.0	7.7	6.5	0.6	8.2	6.9
<b>208 VOLT AND HIGH STATIC DRIVE</b>																
950	6.0	1.3	4.6	3.9	1.1	5.1	4.3	0.8	5.5	4.6	0.4	5.9	5.0	-	-	-
980	5.0	1.6	5.3	4.5	1.4	5.8	4.9	1.2	6.3	5.3	0.7	6.9	5.8	0.2	7.3	6.1
1010	4.0	1.8	5.8	4.9	1.7	6.3	5.3	1.5	6.9	5.8	1.0	7.5	6.3	0.5	7.9	6.7
1020	3.5	1.9	6.1	5.1	1.8	6.5	5.5	1.6	7.1	6.0	1.1	7.8	6.6	0.6	8.3	7.0
1035	3.0	2.0	6.2	5.2	1.9	6.8	5.7	1.7	7.4	6.2	1.2	8.1	6.8	0.7	8.6	7.3
1050	2.5	2.1	6.4	5.4	2.0	7.0	5.9	1.8	7.6	6.4	1.3	8.3	7.0	-	-	-
1075	2.0	2.3	6.6	5.5	2.1	7.2	6.0	1.9	7.8	6.6	1.5	8.6	7.2	-	-	-
1100	1.0	2.4	6.7	5.6	2.2	7.3	6.1	2.1	7.9	6.7	-	-	-	-	-	-
<b>230/460/575 VOLT AND STANDARD DRIVE</b>																
870	6.0**	0.4	2.1	1.8	0.1	2.3	2.0	-	-	-	-	-	-	-	-	-
900	5.0	0.8	3.2	2.7	0.5	3.5	2.9	0.2	3.8	3.2	-	-	-	-	-	-
930	4.0	1.1	4.1	3.4	0.9	4.5	3.8	0.6	4.9	4.1	0.1	5.1	4.3	-	-	-
950	3.5	1.3	4.6	3.9	1.1	5.1	4.3	0.8	5.5	4.6	0.4	5.9	5.0	-	-	-
980	2.5	1.6	5.3	4.5	1.4	5.8	4.9	1.2	6.3	5.3	0.7	6.9	5.8	0.2	7.3	6.1
1015	1.5	1.9	5.9	5.0	1.7	6.5	5.5	1.5	7.0	5.9	1.0	7.7	6.5	0.6	8.2	6.9
1025	1.0	2.0	6.1	5.1	1.8	6.6	5.6	1.6	7.3	6.1	1.1	7.9	6.7	0.7	8.6	7.3
<b>230/460/575 VOLT AND HIGH STATIC DRIVE</b>																
950	6.0	1.3	4.6	3.9	1.1	5.1	4.3	0.8	5.5	4.6	0.4	5.9	5.0	-	-	-
980	5.0	1.6	5.3	4.5	1.4	5.8	4.9	1.2	6.3	5.3	0.7	6.9	5.8	0.2	7.3	6.1
1015	4.0	1.9	5.9	5.0	1.7	6.5	5.5	1.5	7.0	5.9	1.0	7.7	6.5	0.6	8.2	6.9
1035	3.5	2.0	6.2	5.2	1.9	6.8	5.7	1.7	7.4	6.2	1.2	8.1	6.8	0.7	8.6	7.3
1050	3.0	2.1	6.4	5.4	2.0	7.0	5.9	1.8	7.6	6.4	1.3	8.3	7.0	-	-	-
1080	2.0	2.3	6.6	5.5	2.1	7.2	6.0	1.9	7.8	6.6	1.5	8.6	7.2	-	-	-
1100	1.5	2.4	6.7	5.6	2.2	7.3	6.1	2.1	7.9	6.7	-	-	-	-	-	-
1120	1.0	2.5	6.8	5.7	2.3	7.4	6.2	2.2	8.1	6.8	-	-	-	-	-	-

NOTES: 1. Blower performance includes fixed outdoor air, 2" T/A filters, a dry evaporator coil and no electric heat.

2. Refer to Table 13 for additional static resistances.

ESP = External Static Pressure available for the supply and return air duct system. All internal unit resistances have been deducted from the total static pressure of the blower.

\* Do **NOT** close the pulley below 1 turn open.

\*\* Factory setting.

**TABLE 12: SUPPLY AIR BLOWER PERFORMANCE (15 TON) - GAS HEAT  
180 MBH - BOTTOM DUCT CONNECTIONS**

BLOWER SPEED, (RPM)	MOTOR PULLEY (TURNS OPEN)*	CFM														
		4500			5250			6000			6750			7200		
		ESP	BHP	KW	ESP	BHP	KW	ESP	BHP	KW	ESP	BHP	KW	ESP	BHP	KW
<b>208 VOLT AND STANDARD DRIVE</b>																
850	6.0**	0.9	2.4	2.1	0.6	2.9	2.6	0.3	3.4	3.0	-	-	-	-	-	-
870	5.5	1.0	2.5	2.2	0.7	3.0	2.7	0.4	3.5	3.1	-	-	-	-	-	-
915	4.5	1.1	2.6	2.4	0.8	3.1	2.8	0.5	3.6	3.2	0.2	4.1	3.7	-	-	-
965	3.5	1.2	2.7	2.5	0.9	3.2	2.9	0.6	3.7	3.3	0.4	4.4	3.0	0.2	5.0	4.5
980	3.0	1.3	2.9	2.6	1.0	3.4	3.0	0.7	3.8	3.4	0.5	4.5	4.0	0.3	5.1	4.6
1010	2.0	1.4	3.0	2.7	1.1	3.6	3.2	0.8	4.0	3.6	0.6	4.7	4.2	0.4	5.4	4.8
1040	1.0	1.6	3.2	2.9	1.3	3.8	3.4	1.0	4.4	3.9	0.8	5.0	4.5	0.6	5.6	5.0
<b>208 VOLT AND HIGH STATIC DRIVE</b>																
965	6.0	1.2	2.7	2.5	0.9	3.2	2.9	0.6	3.7	3.3	0.4	4.4	3.9	0.2	5.0	4.5
980	5.5	1.3	2.9	2.6	1.0	3.4	3.0	0.7	3.8	3.4	0.5	4.5	4.0	0.3	5.1	4.6
1025	4.5	1.4	3.1	2.8	1.2	3.6	3.2	0.9	4.1	3.7	0.7	4.8	4.3	0.4	5.5	4.9
1065	3.5	1.6	3.4	3.0	1.4	3.9	3.5	1.1	4.5	4.0	0.9	5.1	4.6	-	-	-
1125	2.0	1.9	3.6	3.2	1.7	4.4	3.9	1.4	5.0	4.5	1.2	5.8	5.2	-	-	-
1170	1.0	2.1	3.9	3.5	1.9	4.7	4.2	1.6	5.5	4.9	-	-	-	-	-	-
<b>230/460/575 VOLT AND STANDARD DRIVE</b>																
870	6.0**	1.0	2.5	2.2	0.7	3.0	2.7	0.4	3.5	3.1	-	-	-	-	-	-
915	5.0	1.1	2.6	2.4	0.8	3.1	2.8	0.5	3.6	3.2	0.2	4.1	3.7	-	-	-
965	4.0	1.2	2.7	2.5	0.9	3.2	2.9	0.6	3.7	3.3	0.4	4.4	3.9	0.2	5.0	4.5
980	3.5	1.3	2.9	2.6	1.0	3.4	3.0	0.7	3.8	3.4	0.5	4.5	4.0	0.3	5.1	4.6
1015	2.5	1.4	3.0	2.7	1.1	3.6	3.2	0.8	4.0	3.6	0.6	4.7	4.2	0.4	5.4	4.8
1050	1.5	1.5	3.1	2.8	1.2	3.7	3.3	0.9	4.2	3.8	0.7	4.9	4.4	0.5	5.7	5.1
1065	1.0	1.6	3.4	3.0	1.4	3.9	3.5	1.1	4.5	4.0	0.9	5.1	4.6	-	-	-
<b>230/460/575 VOLT AND HIGH STATIC DRIVE</b>																
980	6.0	1.3	2.9	2.6	1.0	3.4	3.0	0.7	3.8	3.4	0.5	4.5	4.0	0.3	5.1	4.6
1045	4.5	1.6	3.2	2.9	1.3	3.8	3.4	1.0	4.4	3.9	0.8	5.0	4.5	0.6	5.6	5.0
1065	4.0	1.7	3.4	3.0	1.4	3.9	3.5	1.1	4.5	4.0	0.9	5.1	4.6	-	-	-
1125	2.5	1.9	3.6	3.2	1.7	4.4	3.9	1.4	5.0	4.5	1.2	5.8	5.2	-	-	-
1170	1.5	2.1	3.9	3.5	1.8	4.7	4.2	1.6	5.5	4.9	-	-	-	-	-	-
1190	1.0	2.2	4.0	3.6	1.9	4.8	4.3	1.7	5.6	5.0	-	-	-	-	-	-

NOTES: 1. Blower performance includes a gas-fired heat exchanger, fixed outdoor air, two-inch T/A filters and a dry evaporator coil.

2. Refer to the additional Static Resistances table.

ESP = External Static Pressure available for the supply and return air duct system. All internal unit resistances have been deducted from the total static pressure of the blower.

\* Do **NOT** close the pulley below 1 turn open.

\*\* Factory setting.

**TABLE 13: SUPPLY AIR BLOWER PERFORMANCE (17.5 TON) - GAS HEAT  
210 MBH - BOTTOM DUCT CONNECTIONS**

BLOWER SPEED, (RPM)	MOTOR PULLEY (TURNS OPEN)*	CFM											
		6000			7000			8000			9000		
		ESP	BHP	KW	ESP	BHP	KW	ESP	BHP	KW	ESP	BHP	KW
<b>208 VOLT AND STANDARD DRIVE</b>													
870	6.0**	1.3	3.6	3.0	0.7	4.3	3.7	0.2	5.1	4.3	-	-	-
900	5.0	1.4	3.8	3.2	0.9	4.7	4.0	0.4	5.6	4.7	-	-	-
930	4.0	1.6	4.1	3.4	1.1	5.0	4.2	0.6	5.9	5.0	0.1	6.7	5.7
950	3.0	1.7	4.2	3.6	1.3	5.1	4.3	0.8	6.0	5.1	0.2	6.9	5.8
980	2.0	1.9	4.5	3.8	1.5	5.4	4.5	1.0	6.3	5.3	0.4	7.2	6.1
995	1.5	2.1	4.6	3.9	1.6	5.5	4.7	1.1	6.4	5.4	0.5	7.5	6.3
1015	1.0	2.2	4.8	4.0	1.7	5.7	4.8	1.2	6.6	5.6	0.7	7.8	6.6
<b>208 VOLT AND HIGH STATIC DRIVE</b>													
950	6.0	1.7	4.2	3.6	1.3	5.1	4.3	0.8	6.0	5.1	0.2	6.9	5.8
980	5.0	1.9	4.5	3.8	1.5	5.4	4.5	1.0	6.3	5.3	0.4	7.2	6.1
995	4.5	2.1	4.5	3.9	1.6	5.5	4.7	1.1	6.4	5.4	0.5	7.5	6.3
1025	3.5	2.3	4.9	4.1	1.8	5.8	4.9	1.3	6.7	5.7	0.7	8.0	6.7
1050	2.5	2.5	5.1	4.3	2.0	6.1	5.1	1.4	7.1	6.0	0.9	8.4	7.0
1065	2.0	2.6	5.3	4.4	2.1	6.3	5.3	1.5	7.3	6.2	1.0	8.6	7.2
1100	1.0	2.9	5.6	4.7	2.3	6.8	5.7	1.8	7.9	6.6	-	-	-
<b>230/460/575 VOLT AND STANDARD DRIVE</b>													
870	6.0**	1.3	3.6	3.0	0.7	4.3	3.7	0.2	5.1	4.3	-	-	-
900	5.0	1.4	3.8	3.2	0.9	4.7	4.0	0.4	5.6	4.7	-	-	-
930	4.0	1.6	4.1	3.4	1.1	5.0	4.2	0.6	5.9	5.0	0.1	6.7	5.7
950	3.5	1.7	4.2	3.6	1.3	5.1	4.3	0.8	6.0	5.1	0.2	6.9	5.8
965	2.5	1.9	4.5	3.8	1.5	5.4	4.5	1.0	6.3	5.3	0.4	7.2	6.1
995	2.0	2.1	4.6	3.9	1.6	5.5	4.7	1.1	6.4	5.4	0.5	7.5	6.3
1015	1.5	2.2	4.8	4.0	1.7	5.7	4.8	1.2	6.6	5.6	0.6	7.8	6.6
1025	1.0	2.3	4.9	4.1	1.8	5.8	4.9	1.3	6.7	5.7	0.7	8.0	6.7
<b>230/460/575 VOLT AND HIGH STATIC DRIVE</b>													
950	6.0	1.7	4.2	3.6	1.3	5.1	4.3	0.8	6.0	5.1	0.2	6.9	5.8
980	5.0	1.9	4.5	3.8	1.5	5.4	4.5	1.0	6.3	5.3	0.4	7.2	6.1
995	4.5	2.1	4.6	3.9	1.6	5.5	4.7	1.1	6.4	5.4	0.5	7.5	6.3
1015	4.0	2.2	4.8	4.0	1.7	5.7	4.8	1.2	6.6	5.6	0.6	7.8	6.6
1025	3.5	2.3	4.9	4.1	1.8	5.8	4.9	1.3	6.7	5.7	0.7	8.0	6.7
1050	3.0	2.5	5.1	4.3	2.0	6.1	5.1	1.4	7.1	6.0	0.9	8.4	7.0
1065	2.5	2.6	5.3	4.4	2.1	6.3	5.3	1.5	7.3	6.2	1.0	8.6	7.2
1100	1.5	2.9	5.6	4.7	2.3	6.8	4.7	1.8	7.9	6.6	-	-	-
1120	1.0	3.1	5.8	4.9	2.5	7.0	5.9	1.9	8.3	6.9	-	-	-

NOTES: 1. Blower performance includes a gas-fired heat exchanger, fixed outdoor air, two-inch T/A filters and a dry evaporator coil.

2. Refer to the additional Static Resistances table.

ESP = External Static Pressure available for the supply and return air duct system. All internal unit resistances have been deducted from the total static pressure of the blower.

\* Do **NOT** close the pulley below 1 turn open.

\*\* Factory setting.

**TABLE 14: SUPPLY AIR BLOWER PERFORMANCE (20 TON) - GAS HEAT  
240 MBH - BOTTOM DUCT CONNECTIONS**

BLOWER SPEED, (RPM)	MOTOR PULLEY (TURNS OPEN)*	CFM														
		6000			7000			8000			9000			9400		
		ESP	BHP	KW	ESP	BHP	KW	ESP	BHP	KW	ESP	BHP	KW	ESP	BHP	KW
<b>208 VOLT AND STANDARD DRIVE</b>																
870	6.0**	1.3	3.6	3.0	0.7	4.3	3.7	0.2	5.1	4.3	-	-	-	-	-	-
900	5.0	1.4	3.8	3.2	0.9	4.7	4.0	0.4	5.6	4.7	-	-	-	-	-	-
930	4.0	1.6	4.1	3.4	1.1	5.0	4.2	0.6	5.9	5.0	0.1	6.7	5.7	-	-	-
950	3.0	1.7	4.2	3.6	1.3	5.1	4.3	0.8	6.0	5.1	0.2	6.9	5.8	-	-	-
980	2.0	1.9	4.5	3.8	1.5	5.4	4.5	1.0	6.3	5.3	0.4	7.2	6.1	0.1	8.5	7.1
995	1.5	2.1	4.6	3.9	1.6	5.5	4.7	1.1	6.4	5.4	0.5	7.5	6.3	0.2	8.6	7.3
1015	1.0	2.2	4.8	4.0	1.7	5.7	4.8	1.2	6.6	5.6	0.6	7.8	6.6	-	-	-
<b>208 VOLT AND HIGH STATIC DRIVE</b>																
950	6.0	1.7	4.2	3.6	1.3	5.1	4.3	0.8	6.0	5.1	0.2	6.9	5.8	-	-	-
980	5.0	1.9	4.5	3.8	1.5	5.4	4.5	1.0	6.3	5.3	0.4	7.2	6.1	0.1	8.5	7.1
995	4.5	2.1	4.5	3.9	1.6	5.5	4.7	1.1	6.4	5.4	0.5	7.5	6.3	0.2	8.6	7.3
1025	3.5	2.3	4.9	4.1	1.8	5.8	4.9	1.3	6.7	5.7	0.7	8.0	6.7	-	-	-
1050	2.5	2.5	5.1	4.3	2.0	6.1	5.1	1.4	7.1	6.0	0.9	8.4	7.0	-	-	-
1065	2.0	2.6	5.3	4.4	2.1	6.3	5.3	1.5	7.3	6.2	1.0	8.6	7.2	-	-	-
1100	1.0	2.9	5.6	4.7	2.3	6.8	5.7	1.8	7.9	6.6	-	-	-	-	-	-
<b>230/460/575 VOLT AND STANDARD DRIVE</b>																
870	6.0**	1.3	3.6	3.0	0.7	4.3	3.7	0.2	5.1	4.3	-	-	-	-	-	-
900	5.0	1.4	3.8	3.2	0.9	4.7	4.0	0.4	5.6	4.7	-	-	-	-	-	-
930	4.0	1.6	4.1	3.4	1.1	5.0	4.2	0.6	5.9	5.0	0.1	6.7	5.7	-	-	-
950	3.5	1.7	4.2	3.6	1.3	5.1	4.3	0.8	6.0	5.1	0.2	6.9	5.8	-	-	-
965	2.5	1.9	4.5	3.8	1.5	5.4	4.5	1.0	6.3	5.3	0.4	7.2	6.1	0.1	8.5	7.1
995	2.0	2.1	4.6	3.9	1.6	5.5	4.7	1.1	6.4	5.4	0.5	7.5	6.3	0.2	8.6	7.3
1015	1.5	2.2	4.8	4.0	1.7	5.7	4.8	1.2	6.6	5.6	0.6	7.8	6.6	-	-	-
1025	1.0	2.3	4.9	4.1	1.8	5.8	4.9	1.3	6.7	5.7	0.7	8.0	6.7	-	-	-
<b>230/460/575 VOLT AND HIGH STATIC DRIVE</b>																
950	6.0	1.7	4.2	3.6	1.3	5.1	4.3	0.8	6.0	5.1	0.2	6.9	5.8	-	-	-
980	5.0	1.9	4.5	3.8	1.5	5.4	4.5	1.0	6.3	5.3	0.4	7.2	6.1	0.1	8.5	7.1
995	4.5	2.1	4.6	3.9	1.6	5.5	4.7	1.1	6.4	5.4	0.5	7.5	6.3	0.2	8.6	7.3
1015	4.0	2.2	4.8	4.0	1.7	5.7	4.8	1.2	6.6	5.6	0.6	7.8	6.6	-	-	-
1025	3.5	2.3	4.9	4.1	1.8	5.8	4.9	1.3	6.7	5.7	0.7	8.0	6.7	-	-	-
1050	3.0	2.5	5.1	4.3	2.0	6.1	5.1	1.4	7.1	6.0	0.9	8.4	7.0	-	-	-
1065	2.5	2.6	5.3	4.4	2.1	6.3	5.3	1.5	7.3	6.2	1.0	8.6	7.2	-	-	-
1100	1.5	2.9	5.6	4.7	2.3	6.8	4.7	1.8	7.9	6.6	-	-	-	-	-	-
1120	1.0	3.1	5.8	4.9	2.5	7.0	5.9	1.9	8.3	6.9	-	-	-	-	-	-

NOTES: 1. Blower performance includes a gas-fired heat exchanger, fixed outdoor air, two-inch T/A filters and a dry evaporator coil.

2. Refer to the additional Static Resistances table.

ESP = External Static Pressure available for the supply and return air duct system. All internal unit resistances have been deducted from the total static pressure of the blower.

\* Do **NOT** close the pulley below 1 turn open.

\*\* Factory setting.

**TABLE 15: SUPPLY AIR BLOWER PERFORMANCE (25 TON) - GAS HEAT  
300 MBH - BOTTOM DUCT CONNECTIONS**

BLOWER SPEED, (RPM)	MOTOR PULLEY (TURNS OPEN)*	CFM														
		7500			8750			10000			11250			12500		
		ESP	BHP	KW	ESP	BHP	KW	ESP	BHP	KW	ESP	BHP	KW	ESP	BHP	KW
<b>208 VOLT AND STANDARD DRIVE</b>																
975	6.0	1.2	5.9	4.9	5.0	7.3	6.0	-	-	-	-	-	-	-	-	-
1005	5.0	1.4	6.2	5.1	0.7	7.7	6.3	-	-	-	-	-	-	-	-	-
1040	4.0	1.6	6.6	5.4	0.9	8.1	6.7	0.2	9.7	8.0	-	-	-	-	-	-
1070	3.0	1.8	6.9	5.7	1.1	8.5	7.0	0.4	10.2	8.3	-	-	-	-	-	-
1100	2.0	2.0	7.3	6.0	1.3	8.9	7.3	0.6	10.6	8.7	-	-	-	-	-	-
1135	1.0	2.2	7.7	6.3	1.6	9.3	7.6	0.8	11.1	9.1	-	-	-	-	-	-
1165	0.0	2.4	8.0	6.6	1.8	9.7	8.0	1.0	11.6	9.5	0.2	13.5	11.0	-	-	-
<b>208 VOLT AND HIGH STATIC DRIVE</b>																
1140	6.0	2.2	7.7	6.3	1.6	9.4	7.7	0.9	11.2	9.2	-	-	-	-	-	-
1180	5.0	2.5	8.2	6.7	1.9	9.9	8.1	1.2	11.8	9.7	0.3	13.7	11.2	-	-	-
1215	4.0	2.7	8.6	7.0	2.1	10.4	8.5	1.4	12.3	10.1	0.6	14.3	11.7	-	-	-
1255	3.0	3.0	9.1	7.4	2.4	11.0	9.0	1.7	12.9	10.6	0.9	15.0	12.3	-	-	-
1290	2.0	3.2	9.5	7.8	2.7	11.5	9.4	2.0	13.5	11.1	1.2	15.6	12.8	-	-	-
1330	1.0	3.5	10.0	8.2	3.0	12.0	9.9	2.3	14.1	11.6	1.5	16.4	13.4	-	-	-
1365	0.0	3.7	10.5	8.6	3.2	12.6	10.3	2.6	14.7	12.1	1.8	17.0	13.9	-	-	-
<b>230/460/575 VOLT AND STANDARD DRIVE</b>																
975	6.0*	1.4	5.9	4.9	1.0	7.3	6.0	0.5	8.8	7.2	-	-	-	-	-	-
1005	5.0	1.6	6.2	5.1	1.2	7.7	6.3	0.7	9.2	7.6	0.1	10.9	8.9	-	-	-
1040	4.0	1.8	6.6	5.4	1.4	8.1	6.7	0.9	9.7	8.0	0.3	11.4	9.4	-	-	-
1070	3.0	2.0	6.9	5.7	1.6	8.5	7.0	1.1	10.2	8.3	0.6	11.9	9.8	-	-	-
1100	2.0	2.1	7.3	6.0	1.8	8.9	7.3	1.3	10.6	8.7	0.8	12.4	10.2	0.2	14.3	11.7
1135	1.0	2.4	7.7	6.3	2.0	9.3	7.6	1.6	11.1	9.1	1.0	13.0	10.6	0.4	14.9	12.2
1165	0.0	2.6	8.0	6.6	2.2	9.7	8.0	1.8	11.6	9.5	1.3	13.5	11.0	0.7	15.5	12.7
<b>230/460/575 VOLT AND HIGH STATIC DRIVE</b>																
1140	6.0	2.4	7.7	6.3	2.1	9.4	7.7	1.6	11.2	9.2	1.1	13.1	10.7	0.5	15.0	12.3
1180	5.0	2.7	8.2	6.7	2.3	9.9	8.1	1.9	11.8	9.7	1.4	13.7	11.2	0.8	15.8	12.9
1215	4.0	2.9	8.6	7.0	2.6	10.4	8.5	2.2	12.3	10.1	1.7	14.3	11.7	1.1	16.4	13.5
1255	3.0	3.2	9.1	7.4	2.9	11.0	9.0	2.5	12.9	10.6	2.0	15.0	12.3	1.4	17.2	14.1
1290	2.0	3.4	9.5	7.8	3.1	11.5	9.4	2.7	13.5	11.1	2.2	15.6	12.8	-	-	-
1330	1.0	3.7	10.0	8.2	3.4	12.0	9.9	3.0	14.1	11.6	2.6	16.4	13.4	-	-	-
1365	0.0	3.9	10.5	8.6	3.7	12.6	10.3	3.3	14.7	12.1	2.9	17.0	13.9	-	-	-

NOTES: 1. Blower performance includes a gas-fired heat exchanger, fixed outdoor air, two-inch T/A filters and a dry evaporator coil.

2. Refer to the additional Static Resistances table.

ESP = External Static Pressure available for the supply and return air duct system. All internal unit resistances have been deducted from the total static pressure of the blower.

\* Do **NOT** close the pulley below 1 turn open.

\*\* Factory setting.

**TABLE 16: BLOWER MOTOR AND DRIVE DATA**

MODEL SIZE	DRIVE	BLOWER RANGE (RPM)	MOTOR <sup>1</sup>			ADJUSTABLE MOTOR PULLEY				FIXED BLOWER PULLEY				BELT (NOTCHED)		
			HP	FRAME	EFF. (%)	DESIG-NATION	OUTSIDE DIA. (IN.)	PITCH DIA. (IN.)	BORE (IN.)	DESIG-NATION	OUTSIDE DIA. (IN.)	PITCH DIA. (IN.)	BORE (IN.)	DESIG-NATION	PITCH LENGTH (IN.)	QTY.
15 TON	Standard	850/1065	5	184 T	83	1VP56	5.35	4.3-5.3 <sup>2</sup>	1-1/8	BK90	8.75	8.4	1	BX81	82.8	1
	High Static	965/1190								BK80	7.75	7.4	1	BX78	79.8	1
17.5 & 20 TON	Standard	870/1025	7.5	213 T	89	1VP68	6.75	5.5-6.5 <sup>2</sup>	1-3/8	BK120	11.75	11.4	1-3/16	BX83	84.8	1
	High Static	950/1120								BK110	10.75	10.4	1-3/16	BX81	82.8	1
25 TON	Standard	975/1165	15	254 T	91	1VP75X	7.5	6.2-7.4 <sup>2</sup>	1-5/8	1B5V110	11.3	11.1	1-7/16	5VX860	86.0	1
	High Static	1140/1365								1B5V94	9.7	9.5	1-7/16	5VX840	84.0	1

- All motors have a nominal speed of 1800 RPM, a 1.15 service factor and a solid base. They can operate to the limit of their service factor because they are located in the moving air, upstream of any heating device.
- Do NOT close this pulley below 1 turn open.

**TABLE 17: STATIC RESISTANCES<sup>1</sup>**

DESCRIPTION		RESISTANCE, IWG											
		CFM											
		15 TON			17.5 TON			20 TON			25 TON		
		4500	6000	7200	6000	7500	9000	6000	8000	9400	7500	10000	12500
WET INDOOR COIL		0.1	0.1	0.1	0.1	0.1	0.1	0.1	0.1	0.1	0.1	0.1	0.1
ELECTRIC HEAT OPTIONS	18 KW	0.3	0.4	0.4	0.4	0.4	0.5	0.4	0.4	0.5	0.4	0.5	0.6
	36 KW	0.3	0.4	0.5	0.4	0.5	0.5	0.4	0.5	0.5	0.5	0.5	0.6
	54 KW	0.4	0.5	0.5	0.5	0.5	0.6	0.5	0.5	0.6	0.5	0.6	0.7
	72 KW	0.4	0.5	0.5	0.5	0.5	0.6	0.5	0.5	0.6	0.5	0.6	0.7
ECONOMIZER OPTION		0.1	0.1	0.1	0.1	0.1	0.2	0.1	0.1	0.2	0.1	0.2	0.3
HORIZONTAL DUCT CONNECTIONS <sup>2</sup>		0.1	0.2	0.3	0.2	0.3	0.5	0.2	0.3	0.5	0.3	0.5	0.6

- Deduct these resistance values from the available external static pressures shown in the respective Blower Performance Table (See Note 2 for exception.)
- Since the resistance to air flow will be less for horizontal duct connections than for bottom duct connections, add these pressures to the ESP values on the respective unit's blower performance table.

**TABLE 18: POWER EXHAUST PERFORMANCE**

MOTOR SPEED <sup>1</sup>	STATIC RESISTANCE OF RETURN DUCTWORK, IWG									
	0.2		0.3		0.4		0.5		0.6	
	CFM	kW	CFM	kW	CFM	kW	CFM	kW	CFM	kW
HIGH <sup>2</sup>	5250	0.83	4500	0.85	4200	0.88	3750	0.93	3000	0.99
MEDIUM	4900	0.77	3900	0.79	3500	0.82	2900	0.85	-	-
LOW	4400	0.72	3700	0.74	3000	0.78	-	-	-	-

- Power exhaust motor is a 3/4 HP, PSC type with sleeve bearings, a 48 frame and inherent protection.
- The factory setting.

**TABLE 19: J\*\*DJ ELECTRICAL DATA WITHOUT POWERED CONVENIENCE OUTLET**

MODEL (TON-NAGE)	VOLTAGE	COMPRESSORS		OD FAN MOTORS FLA EACH	ID BLOWER MOTOR FLA	CONV OUTLET AMPS	HEATER OPTION				MIN. CIRCUIT AMPACITY (AMPS)	MAX. FUSE/ BRKR <sup>1</sup> SIZE (AMPS)
		RLA EACH	LRA EACH				MODEL	KW	STAGES	AMPS		
J15 (15)	208	22.4	164	2.1	15.4	0.0	None	0.0	~	~	74.2	90
							E18	13.5	1	37.5	74.2	90
							E36	27.0	2	75.1	112.9	125
							E54	40.6	2	112.6	160.1	175
							E72	54.1	2	150.1	169.4	200
	230	22.4	164	2.1	15.4	0.0	None	0.0	~	~	73.2	90
							E18	18.0	1	43.3	73.2	90
							E36	36.0	2	86.6	126.3	150
							E54	54.0	2	129.9	147.9	175
							E72	72.0	2	173.2	191.2	225
	460	10.9	100	1.1	7.2	0.0	None	0.0	~	~	36.1	45
							E18	18.0	1	21.7	36.1	45
							E36	36.0	2	43.3	63.1	70
							E54	54.0	2	65.0	74.0	90
							E72	72.0	2	86.6	95.6	110
	575	8.3	78	0.9	5.9	0.0	None	0.0	~	~	28.2	35
E18							18.0	1	17.3	29.0	35	
E36							36.0	2	34.6	50.7	60	
E54							54.0	2	52.0	59.3	70	
E72							72.0	2	69.3	76.7	90	
J18 (17 1/2)	208	25.6	190	2.1	20.0	0.0	None	0.0	~	~	86.0	110
							E18	13.5	1	37.5	86.0	110
							E36	27.0	2	75.1	118.7	125
							E54	40.6	2	112.6	165.9	175
							E72	54.1	2	150.1	175.2	200
	230	25.6	190	2.1	20.0	0.0	None	0.0	~	~	86.0	110
							E18	18.0	1	43.3	86.0	110
							E36	36.0	2	86.6	133.3	150
							E54	54.0	2	129.9	154.9	175
							E72	72.0	2	173.2	198.2	225
	460	12.8	95	1.1	10.0	0.0	None	0.0	~	~	43.2	50
							E18	18.0	1	21.7	43.2	50
							E36	36.0	2	43.3	66.6	70
							E54	54.0	2	65.0	77.5	90
							E72	72.0	2	86.6	99.1	110
	575	10.3	75	0.9	8.2	0.0	None	0.0	~	~	35.0	45
E18							18.0	1	17.3	35.0	45	
E36							36.0	2	34.6	53.6	60	
E54							54.0	2	52.0	62.2	70	
E72							72.0	2	69.3	79.5	90	

NOTE 1: HACR Type per NEC.



**TABLE 19: J\*\*DJ ELECTRICAL DATA WITHOUT POWERED CONVENIENCE OUTLET (CONTINUED)**

MODEL (TON-NAGE)	VOLTAGE	COMPRESSORS		OD FAN MOTORS FLA EACH	ID BLOWER MOTOR FLA	CONV OUTLET AMPS	HEATER OPTION				MIN. CIRCUIT AMPACITY (AMPS)	MAX. FUSE/ BRKR <sup>1</sup> SIZE (AMPS)
		RLA EACH	LRA EACH				MODEL	KW	STAGES	AMPS		
J20 (20)	208	33.6	225	3.7	20.0	0.0	None	0.0	~	~	110.4	125
							E18	13.5	1	37.5	110.4	125
							E36	27.0	2	75.1	118.7	125
							E54	40.6	2	112.6	165.9	175
	230	33.6	225	3.7	20.0	0.0	None	0.0	~	~	110.4	125
							E18	18.0	1	43.3	110.4	125
							E36	36.0	2	86.6	133.3	150
							E54	54.0	2	129.9	154.9	175
	460	17.3	114	1.9	10.0	0.0	None	0.0	~	~	56.5	70
							E18	18.0	1	21.7	56.5	70
							E36	36.0	2	43.3	66.6	70
							E54	54.0	2	65.0	77.5	90
	575	13.5	80	1.5	8.2	0.0	None	0.0	~	~	44.6	50
							E18	18.0	1	17.3	44.6	50
							E36	36.0	2	34.6	53.6	60
							E54	54.0	2	52.0	62.2	70
J25 (25)	208	47.1	245	3.7	38.6	0.0	None	0.0	~	~	159.4	200
							E18	13.5	1	37.5	159.4	200
							E36	27.0	2	75.1	159.4	200
							E54	40.6	2	112.6	189.1	200
	230	47.1	245	3.7	38.6	0.0	None	0.0	~	~	159.4	200
							E18	18.0	1	43.3	159.4	200
							E36	36.0	2	86.6	159.4	200
							E54	54.0	2	129.9	178.2	200
	460	19.6	125	1.9	19.3	0.0	None	0.0	~	~	71.0	90
							E18	18.0	1	21.7	71.0	90
							E36	36.0	2	43.3	78.3	90
							E54	54.0	2	65.0	89.1	100
	575	15.8	100	1.5	15.4	0.0	None	0.0	~	~	57.0	70
							E18	18.0	1	17.3	57.0	70
							E36	36.0	2	34.6	62.6	70
							E54	54.0	2	52.0	71.2	80
						None	0.0	~	~	88.5	100	
						E18	18.0	1	17.3	88.5	100	
						E36	36.0	2	34.6	88.5	100	
						E54	54.0	2	52.0	88.5	100	

NOTE 1: HACR Type per NEC.

TABLE 20: J\*\*DJ ELECTRICAL DATA WITH POWERED CONVENIENCE OUTLET

MODEL (TON-NAGE)	VOLTAGE	COMPRESSORS		OD FAN MOTORS FLA EACH	ID BLOWER MOTOR FLA	CONV OUTLET AMPS	HEATER OPTION				MIN. CIRCUIT AMPACITY (AMPS)	MAX. FUSE/ BRKR <sup>1</sup> SIZE (AMPS)
		RLA EACH	LRA EACH				MODEL	KW	STAGES	AMPS		
J15 (15)	208	22.4	164	2.1	15.4	10.0	None	0.0	~	~	84.2	100
							E18	13.5	1	37.5	84.2	100
							E36	27.0	2	75.1	125.4	150
							E54	40.6	2	112.6	172.6	175
							E72	54.1	2	150.1	181.9	200
	230	22.4	164	2.1	15.4	10.0	None	0.0	~	~	83.2	100
							E18	18.0	1	43.3	84.6	100
							E36	36.0	2	86.6	138.8	150
							E54	54.0	2	129.9	160.4	175
							E72	72.0	2	173.2	203.7	225
	460	10.9	100	1.1	7.2	5.0	None	0.0	~	~	41.1	50
							E18	18.0	1	21.7	42.3	50
							E36	36.0	2	43.3	69.4	70
							E54	54.0	2	65.0	80.2	90
							E72	72.0	2	86.6	101.9	110
	575	8.3	78	0.9	5.9	4.0	None	0.0	~	~	32.2	40
E18							18.0	1	17.3	34.0	40	
E36							36.0	2	34.6	55.7	60	
E54							54.0	2	52.0	64.3	70	
E72							72.0	2	69.3	81.7	90	
J18 (17 1/2)	208	25.6	190	2.1	20.0	10.0	None	0.0	~	~	96.0	110
							E18	13.5	1	37.5	96.0	110
							E36	27.0	2	75.1	131.2	150
							E54	40.6	2	112.6	178.4	200
							E72	54.1	2	150.1	187.7	200
	230	25.6	190	2.1	20.0	10.0	None	0.0	~	~	96.0	110
							E18	18.0	1	43.3	96.0	110
							E36	36.0	2	86.6	145.8	150
							E54	54.0	2	129.9	167.4	175
							E72	72.0	2	173.2	210.7	225
	460	12.8	95	1.1	10.0	5.0	None	0.0	~	~	48.2	60
							E18	18.0	1	21.7	48.2	60
							E36	36.0	2	43.3	72.9	80
							E54	54.0	2	65.0	83.7	90
							E72	72.0	2	86.6	105.4	110
	575	10.3	75	0.9	8.2	4.0	None	0.0	~	~	39.0	45
E18							18.0	1	17.3	39.0	45	
E36							36.0	2	34.6	58.6	60	
E54							54.0	2	52.0	67.2	70	
E72							72.0	2	69.3	84.5	90	

NOTE 1: HACR Type per NEC.

**TABLE 20: J\*\*DJ ELECTRICAL DATA WITH POWERED CONVENIENCE OUTLET (CONTINUED)**

MODEL (TON-NAGE)	VOLTAGE	COMPRESSORS		OD FAN MOTORS FLA EACH	ID BLOWER MOTOR FLA	CONV OUTLET AMPS	HEATER OPTION				MIN. CIRCUIT AMPACITY (AMPS)	MAX. FUSE/ BRKR <sup>1</sup> SIZE (AMPS)
		RLA EACH	LRA EACH				MODEL	KW	STAGES	AMPS		
J20 (20)	208	33.6	225	3.7	20.0	10.0	None	0.0	~	~	120.4	150
							E18	13.5	1	37.5	120.4	150
							E36	27.0	2	75.1	131.2	150
							E54	40.6	2	112.6	178.4	200
							E72	54.1	2	150.1	187.7	200
	230	33.6	225	3.7	20.0	10.0	None	0.0	~	~	120.4	150
							E18	18.0	1	43.3	120.4	150
							E36	36.0	2	86.6	145.8	150
							E54	54.0	2	129.9	167.4	175
							E72	72.0	2	173.2	210.7	225
	460	17.3	114	1.9	10.0	5.0	None	0.0	~	~	61.5	70
							E18	18.0	1	21.7	61.5	70
							E36	36.0	2	43.3	72.9	80
							E54	54.0	2	65.0	83.7	90
							E72	72.0	2	86.6	105.4	110
	575	13.5	80	1.5	8.2	4.0	None	0.0	~	~	48.6	60
							E18	18.0	1	17.3	48.6	60
							E36	36.0	2	34.6	58.6	60
							E54	54.0	2	52.0	67.2	70
							E72	72.0	2	69.3	84.5	90
J25 (25)	208	47.1	245	3.7	38.6	10.0	None	0.0	~	~	169.4	200
							E18	13.5	1	37.5	169.4	200
							E36	27.0	2	75.1	169.4	200
							E54	40.6	2	112.6	201.6	225
							E72	54.1	2	150.1	210.9	225
	230	47.1	245	3.7	38.6	10.0	None	0.0	~	~	169.4	200
							E18	18.0	1	43.3	169.4	200
							E36	36.0	2	86.6	169.4	200
							E54	54.0	2	129.9	190.7	225
							E72	72.0	2	173.2	234.0	250
	460	19.6	125	1.9	19.3	5.0	None	0.0	~	~	76.0	90
							E18	18.0	1	21.7	76.0	90
							E36	36.0	2	43.3	84.5	90
							E54	54.0	2	65.0	95.3	110
							E72	72.0	2	86.6	117.0	125
	575	15.8	100	1.5	15.4	4.0	None	0.0	~	~	61.0	70
							E18	18.0	1	17.3	61.0	70
							E36	36.0	2	34.6	67.6	70
							E54	54.0	2	52.0	76.2	90
							E72	72.0	2	69.3	93.5	100

NOTE 1: HACR Type per NEC.

**TABLE 21: J\*\*DJ VOLTAGE LIMITATIONS<sup>1</sup>**

VOLTAGE LIMITATIONS			
VOLTAGE LIMITATIONS	POWER SUPPLY	VOLTAGE	
		MIN.	MAX.
	208/230-3-60	187	253
	460-3-60	414	506
575-3-60	518	630	

<sup>1</sup>. Utilization Range "A" in accordance with ARI Standard 110.

**TABLE 22: PHYSICAL DATA**

MODELS		J15DJ	J18DJ	J20DJ	J25DJ		
EVAPORATOR BLOWER	CENTRIFUGAL BLOWER (Dia. x Wd.)	15x15	18x15	18x15	18x15		
	FAN MOTOR HP	5.0	7.5	7.5	15		
EVAPORATOR COIL	ROWS DEEP	4					
	FINS PER INCH	13.5					
	FACE AREA (Sq. Ft.)	25					
CONDENSER FAN (Four Per Unit)	PROPELLER DIA. (In.) (Each)	24	24	30	30		
	FAN MOTOR HP (Each)	1/3	1/3	3/4	3/4		
	NOM. CFM TOTAL (Each)	4,000	4,000	5,000	5,000		
CONDENSER COIL	ROWS DEEP	2					
	FINS PER INCH	20					
	FACE AREA (Sq. Ft.)	63.8					
COMPRESSOR (Qty. Per Unit)	SCROLL	2					
FILTERS	QUANTITY PER UNIT (12" X 24" X 2")	12					
	TOTAL FACE AREA (Sq. Ft.)	24					
CHARGE	REFRIGERANT 22 (Lb./Oz.)	SYSTEM No.1	23/0	24/0	23/8	23/8	
		SYSTEM No. 2	23/8	24/0	23/8	23/8	
OPERATING WEIGHTS (LBS.)	BASIC UNIT	COOLING ONLY	2260	2540	2560	2660	
		GAS / ELECTRIC	N24	2460	2740	2760	2860
	N32		2500	2780	2800	2900	
	OPTIONS	DOUBLE WALL	260				
		ECONOMIZER	160				
		ECONOMIZER WITH POWER EXHAUST	245				
		MOTORIZED DAMPER	150				
		ELECTRIC HEATER	18 KW	25			
			36 KW	30			
			54 KW	35			
			72 KW	40			
		HOT GAS BYPASS	10				
		SUPPLY FAN VFD	See Table 23				
	ACCESSORIES	ROOF CURB	185				
		BAROMETRIC DAMPER	45				
		ECONOMIZER / MOTORIZED DAMPER RAIN HOOD	55				
		ECONOMIZER / POWER EXHAUST RAIN HOOD	90				
WOOD SKID		220					

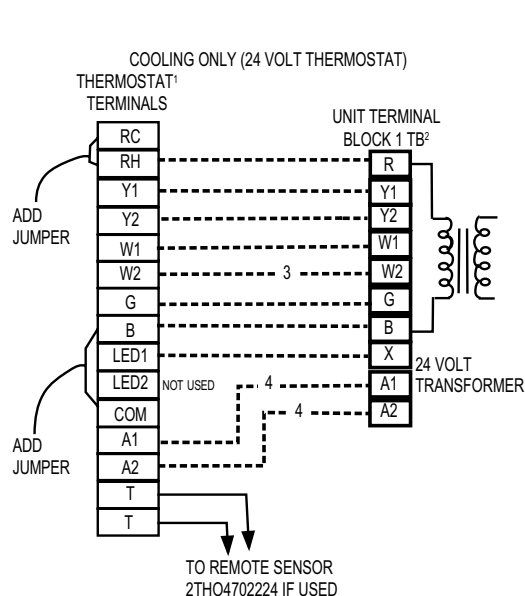
**TABLE 23: SUPPLY FAN VFD WEIGHTS, IN LBS.**

SUPPLY FAN MOTOR	230V	460V	575V
<b>W/O MANUAL BYPASS</b>			
5.0 hp	25	25	30
7.5 hp	30	30	30
10.0 hp	30	30	35
15.0 hp	30	30	40
<b>W/MANUAL BYPASS</b>			
5.0 hp	30	30	35
7.5 hp	35	35	35
10.0 hp	35	35	40
15.0 hp	40	35	45

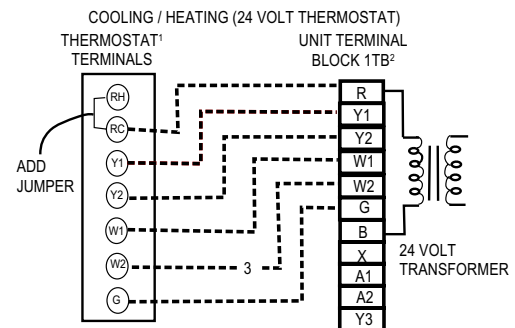
**TABLE 24: ELECTRIC HEAT CORRECTION FACTORS**

NOMINAL VOLTAGE	VOLTAGE	kW CAP. MULTIPLIER
208	208	1.00
240	230	0.92
480	460	0.92
600	575	0.92

**CONTROL WIRING**

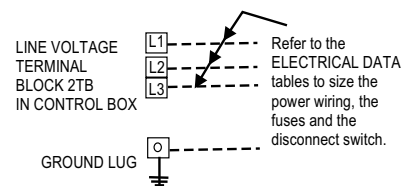


<sup>1</sup>Electronic programmable thermostat 2ET04700224 (includes subbase).  
<sup>2</sup>Terminal block 1TB- located on relay board in 24-volt section of the unit control box.  
<sup>3</sup>Second stage heating is not required on units with a single stage electric heater.  
<sup>4</sup>Terminals A1 and A2 provide a relay output to close the outdoor economizer dampers when the thermostat switches to the set-back position.  
 NOTE: Fans switch must be in "ON" position for minimum ventilation during heater operation.

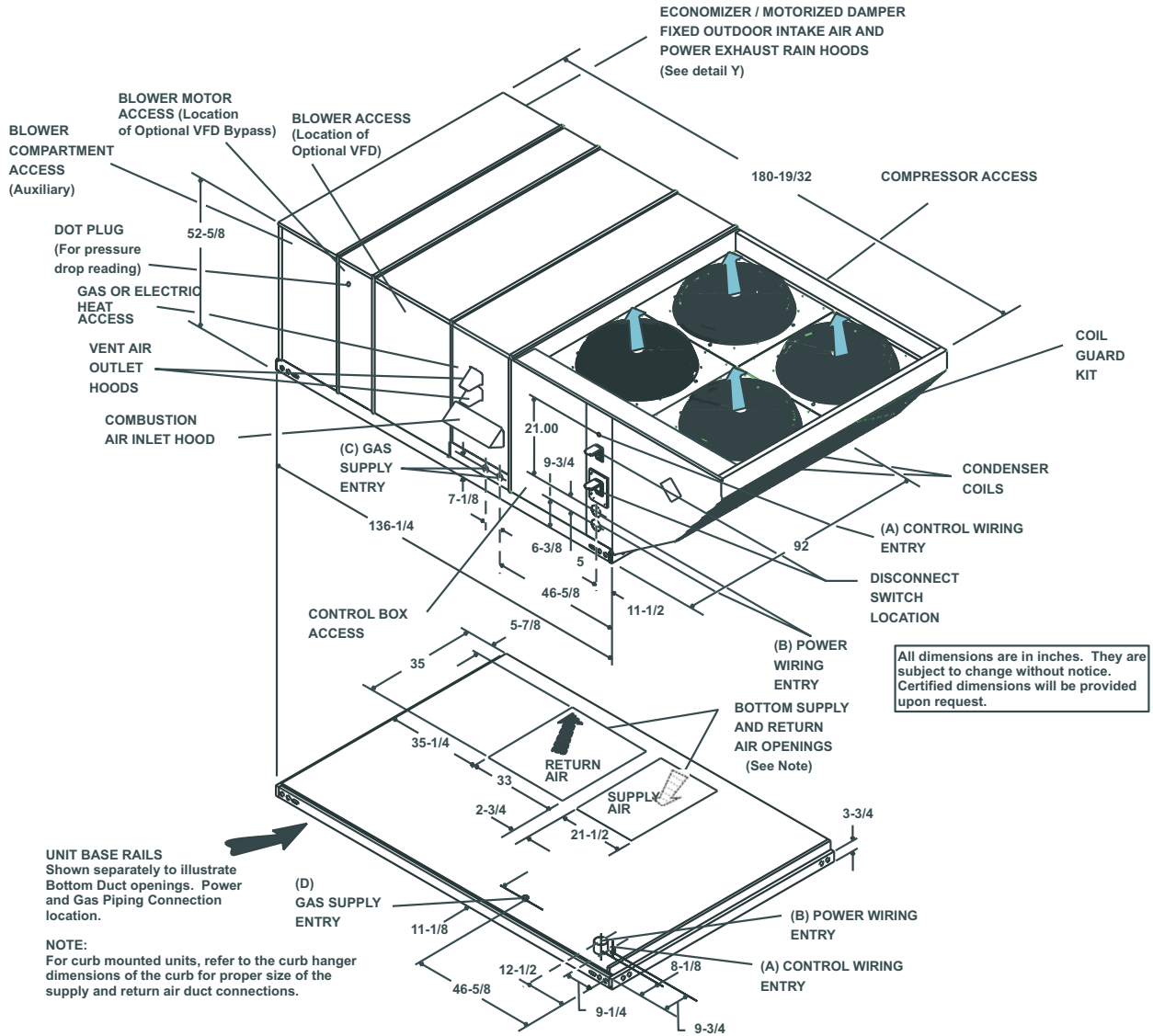


<sup>1</sup>24 Volt Thermostat 2TH04701024 or 2TH04701524 (with Subbase 2TB04700324).  
<sup>2</sup>Terminal strip 1TB - located on relay board in 24-volt section of the unit control box.  
<sup>3</sup>Second stage heating is not required on units with a single stage electric heater.

**POWER WIRING**



**FIGURE 3 - TYPICAL J\*\*DJ FIELD WIRING DIAGRAM**



**FIGURE 4 - FRONT VIEW DIMENSIONS**

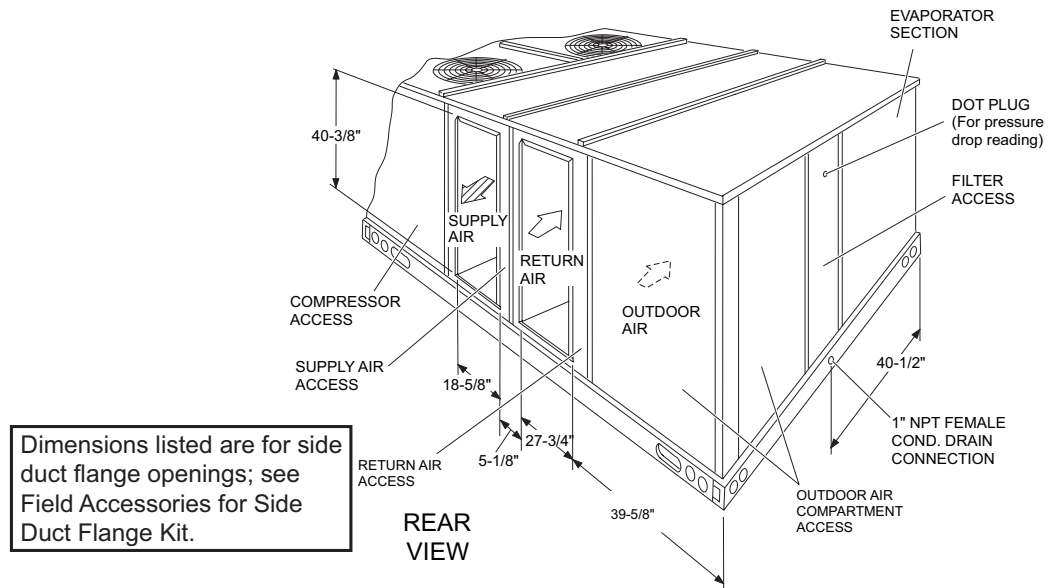
**TABLE 25: UTILITIES ENTRY DATA**

HOLE	OPENING SIZE (DIA.)	USED FOR	
A	1-1/8" KO	Control Wiring	Side
	3/4" NPS (Fem.)		Bottom
B	3-5/8" KO	Power Wiring	Side
	3" NPS (Fem.)		Bottom
C	2-3/8" KO	Gas Piping (Front) <sup>1</sup>	
D	1-11/16" Hole	Gas Piping (Bottom) <sup>1, 2</sup>	

<sup>1</sup>. One-inch gas piping NPT required.

<sup>2</sup>. Opening in the bottom of the unit can be located by the slice in the insulation.

NOTE: All entry holes should be field sealed to prevent rain water entry into the building.



**FIGURE 5 - REAR VIEW DIMENSIONS**

**NOTE:** Units are shipped with the bottom duct openings covered. An accessory flange kit is available for connecting side ducts.

**For bottom duct applications:**

1. Remove the side panels from the supply and return air compartments to gain access to the bottom supply and return air duct covers.
2. Remove and discard the bottom duct covers. Duct openings are closed with sheet metal covers except when the unit includes a power exhaust option. The covering consists of a heavy black paper composition.
3. Replace the side supply and return air compartment panels.

**For side duct applications:**

1. Replace the side panels on the supply and return air compartments with the side duct flange accessory kit panels.
2. Connect ductwork to the flanges on those panels.

**TABLE 26: MINIMUM CLEARANCES**

LOCATION	CLEARANCE
Front	36"
Rear	24" (Less Economizer) 49" (With Economizer)
Left Side (Filter Access)	24" (Less Economizer) 36" (With Economizer) <sup>3</sup>
Right Side (Cond. Coil)	36"
Below Unit <sup>1</sup>	0"
Above Unit <sup>2</sup>	72" With 36" Maximum Horizontal Overhang (For Condenser Air Discharge)

1. Units may be installed on combustible floors made from wood or class A, B, or C roof covering material.
2. Units must be installed outdoors. Overhanging structures or shrubs should not obstruct condenser air discharge outlet.
3. If economizer is factory installed, the unassembled rain hood must be removed from its ride along position in front of evaporator coil, or in the outdoor air compartment, prior to final installation.

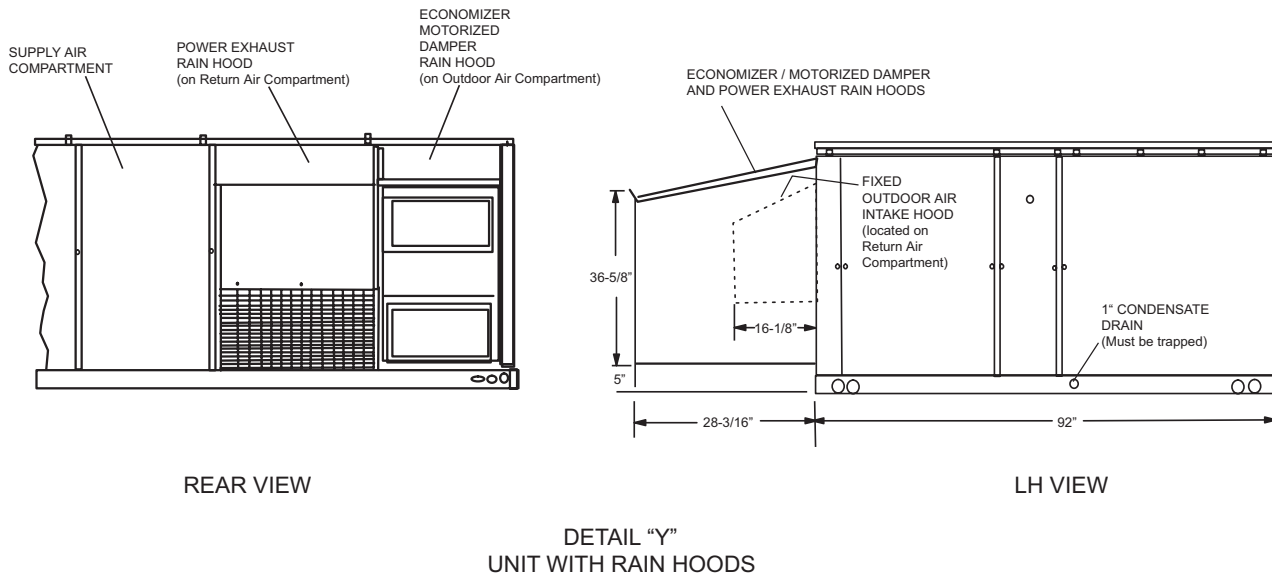
NOTE: ELEC / ELEC Models: Units and ductwork are approved for zero clearance to combustible material when equipped with electric heaters.

GAS / ELEC Models: A 1" clearance must be provided between any combustible material and the supply air ductwork for a distance of 3 feet from the unit.

The products of combustion must not be allowed to accumulate within a confined space and recirculate.

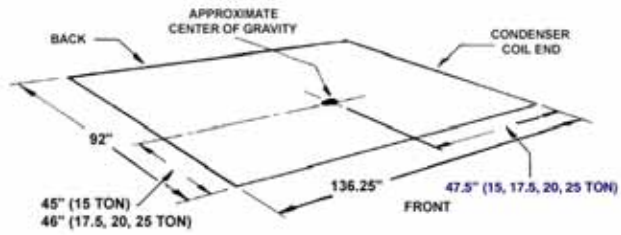
Locate unit so that the vent air outlet hood is at least:

- Three (3) feet above any force air inlet located within 10 horizontal feet (excluding those integral to the unit).
- Four (4) feet below, four horizontal feet from, or one foot above any door or gravity air inlet into the building.
- Four (4) feet from electric and gas meters, regulators and relief equipment.

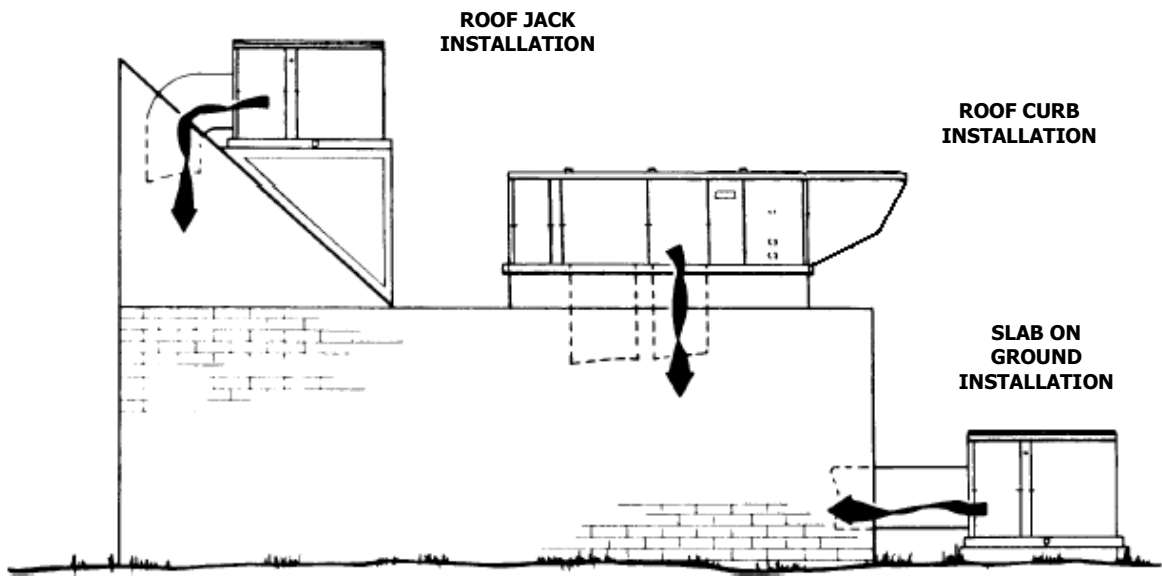


**FIGURE 6 - UNIT DIMENSIONS J15, 18, 20 & 25 DJ (RAINHOOD)**

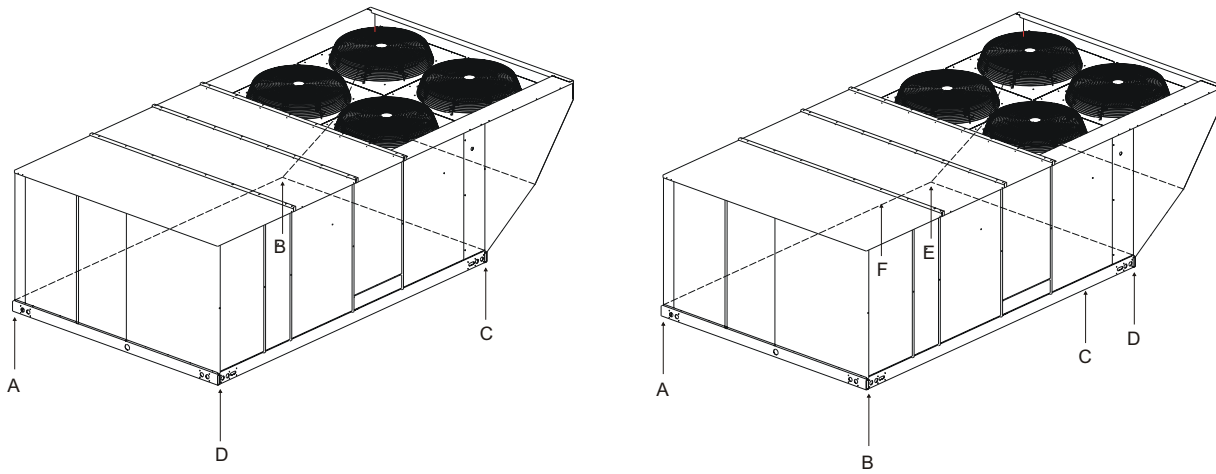




**FIGURE 7 - UNIT CENTER OF GRAVITY**



**FIGURE 8 - TYPICAL UNIT APPLICATIONS**



**FIGURE 9 - FOUR AND SIX POINT LOADS**

**TABLE 27: FOUR AND SIX POINT LOADS**

Unit Size	Total Shipping Weight	4 Point Loads (lbs)			
		A	B	C	D
J15DJ Gas	2660	454	847	885	474
J18DJ Gas	2928	510	954	954	510
J20DJ Gas	2960	516	964	964	516
J25DJ Gas	3046	531	992	992	531
J15DJ Elec	2460	419	784	819	438
J18DJ Elec	2728	476	888	888	476
J20DJ Elec	2760	481	899	899	481
J25DJ Elec	2846	496	927	927	496

Unit Size	Total Shipping Weight	6 Point Loads (lbs)					
		A	B	C	D	E	F
J15DJ Gas	2660	302	316	453	590	565	434
J18DJ Gas	2928	340	340	488	636	636	488
J20DJ Gas	2960	344	344	493	643	643	493
J25DJ Gas	3046	354	354	508	661	661	508
J15DJ Elec	2460	280	292	419	546	523	401
J18DJ Elec	2728	317	317	455	592	592	455
J20DJ Elec	2760	321	321	460	599	599	460
J25DJ Elec	2846	331	331	474	618	618	474

Note: These weights are with economizer and high option heat (gas or electric).

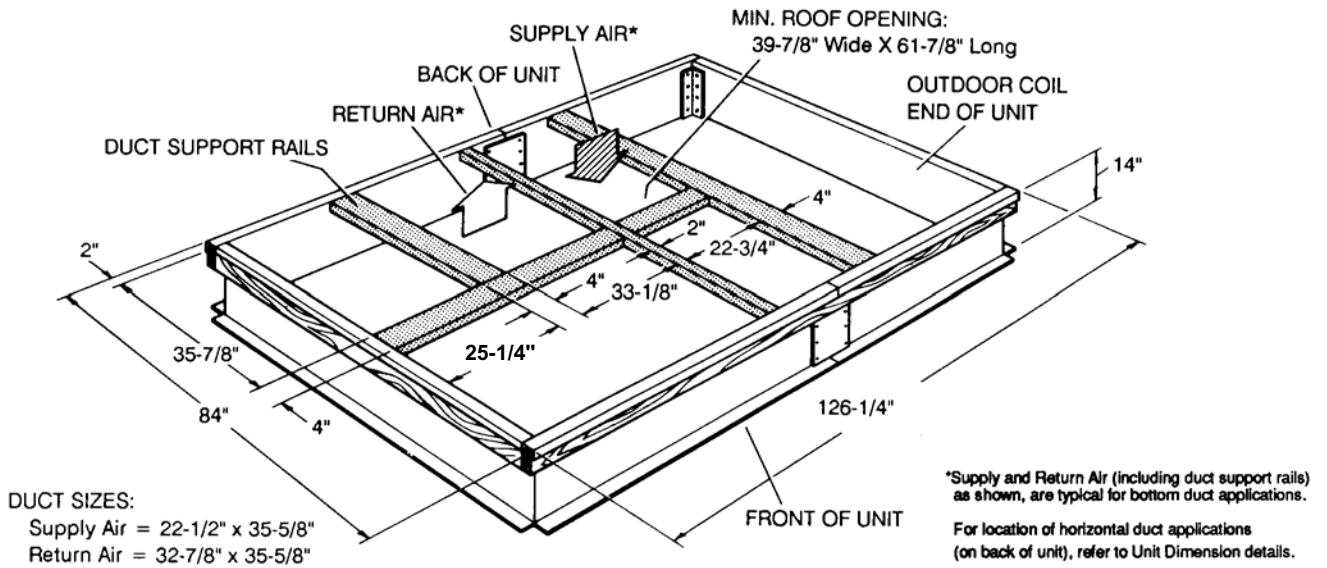


FIGURE 10 - UNIT ROOF CURB DIMENSIONS

- The 58-1/2" overall dimension of the ducts allows duct-work penetration between roof joists that are spaced on 72" centers.

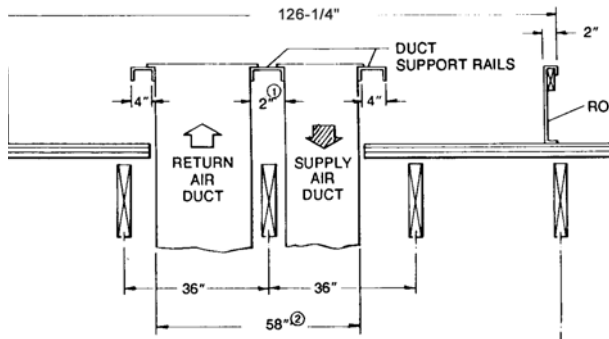


FIGURE 11 - ROOF CURB DUCT OPENINGS DIMENSION

- The 2" space between the ducts allows for "jumping" an existing roof joist.

**Note:** Ducts can be installed into the curb from the roof. All electrical and gas line connections can be made inside the curb.

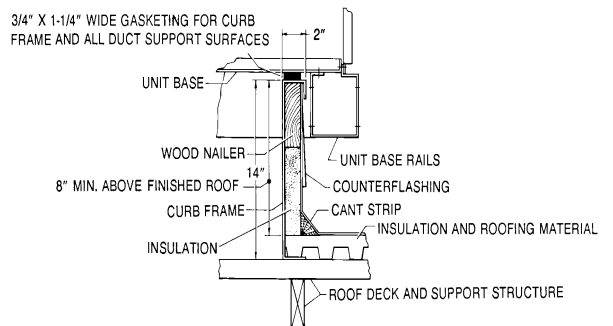
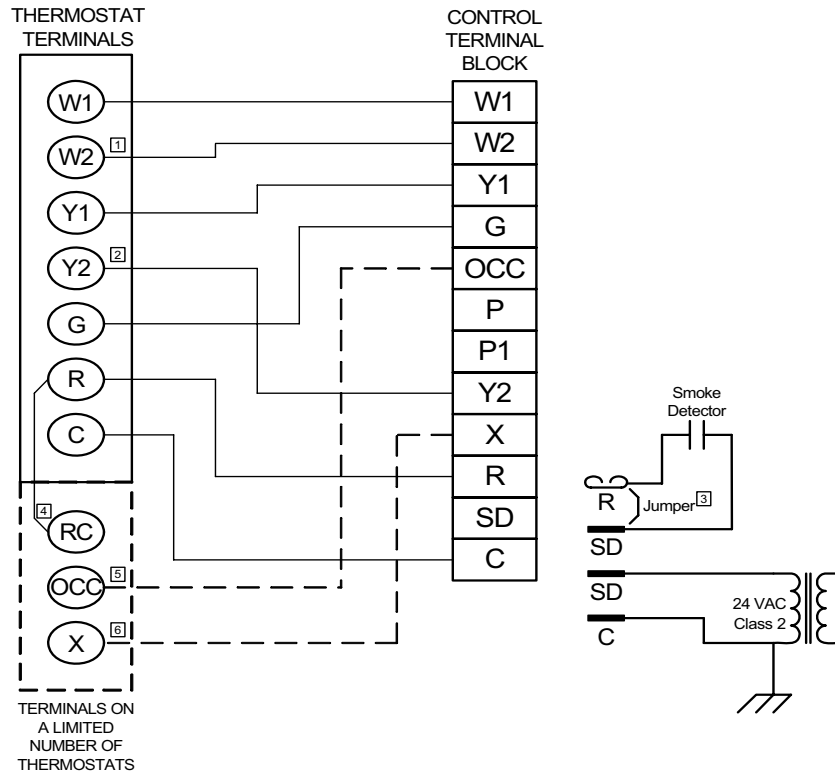


FIGURE 12 - CUT AWAY OF ROOF CURB



- ❶ Second stage heating not required on single stage heating units.
- ❷ Second stage cooling not required on single stage cooling units.
- ❸ Jumper is required if there is no Smoke Detector circuit.
- ❹ Jumper is required for any combination of R, RC, or RH.
- ❺ OCC is an output from the thermostat to indicate the Occupied condition.
- ❻ X is an input to the thermostat to display Error Status conditions.

**FIGURE 13 - TYPICAL UNIT WIRING DIAGRAM**

## GUIDE SPECIFICATIONS

### GENERAL

Units shall be manufactured by Johnson Controls in an ISO 9001 certified facility.

Series 20 J\*\*DJ units are convertible single package units. All models have dual independent refrigerant circuits for efficient part load operation and maximum comfort control. Although the units are primarily designed for curb mounting on a roof, they can also be slab-mounted at ground level or set on steel beams above a finished roof. Cooling only, cooling with gas heat and cooling with electric heat models are available with a wide variety of factory-mounted options and field-installed accessories to make them suitable for almost every application. All units are self-contained and assembled on full perimeter base rails with holes in the four corners for overhead rigging. Every unit is completely piped, wired, charged and tested at the factory to simplify the field installation and to provide years of dependable operation. All models (including those with an economizer) are suitable for either bottom or horizontal duct connections. Models with power exhaust are suitable for bottom duct connections only. For bottom duct, remove the sheet metal panels from the supply and return air openings through the base of the unit. For horizontal duct, replace the supply and return air panels on the rear of the unit with a side duct flange accessory. All supply air blowers are equipped with a belt drive that can be adjusted to meet the exact requirements of the job. A high static drive option is available for applications with a higher CFM and/or static pressure requirement.

Each unit shall have 4 condenser fan motors. All compressors include crankcase heat and internal pressure relief. Every refrigerant circuit includes an expansion valve, a liquid line filter-drier, a discharge line high pressure switch and a suction line with a freeze-stat and low pressure/loss of charge switch. The unit control circuit includes a 75 VA transformer, a 24-volt circuit breaker and a relay board with two compressor lockout circuits, a terminal strip for thermostat wiring, plus an additional set of pin connectors to simplify the interface of additional field controls. All units have long lasting powder paint cabinets with 750 hour salt spray test approval under ASTM-B117 procedures. All models are CSA approved. All models include a 1-year limited warranty on the complete unit. Compressors and electric heater elements carry an additional 4-year warranty. Aluminized steel tubular heat exchangers carry an additional 9-year warranty.

### DESCRIPTION

Units shall be factory-assembled, single packaged, J\*\*DJN Electric Cooling/Gas Heat, J\*\*DJC/E Electric Cooling/Optional Electric Heat, designed for outdoor mounted installation. The 15, 17.5, and 20 ton units shall have minimum EER ratings of 11.1. The 25 ton unit shall have a minimum EER rating of 10.5.

They shall have built-in field convertible duct connections for down discharge supply/return or horizontal discharge supply/return, and be available with factory installed options or field installed accessories. The units shall be factory wired, piped, charged with R-22 refrigerant and factory tested prior to shipment. All unit wiring shall be both numbered and color coded. All units shall be manufactured in a facility certified to ISO 9001 standards and the cooling performance shall be rated in accordance with DOE and ARI test procedures. Units shall be CSA listed, classified to ANSI Z21.47 standards, UL 1995/CAN/CSA No. 236-M90 conditions.

### UNIT CABINET

Unit cabinet shall be constructed of a combination of G60 and G90 galvanized steel, with exterior surfaces coated with a non-chalking, powdered paint finish, certified at 750 hours salt spray test per ASTM B117 standards. Indoor blower section shall be insulated with a minimum 1/2" thick insulation, coated on the airside. Aluminum foil faced insulation shall be used in the furnace compartment and be fastened with ridged fasteners to prevent insulation from entering the air stream. Cabinet panels shall be "large" size, easily removable for servicing and maintenance. Full perimeter base rails shall be provided to assure reliable transit of equipment, overhead rigging and proper sealing on roof curb applications. Disposable 2" filters shall be furnished and be accessible through a removable access door, sealed airtight. Units filter track shall be designed to accommodate either 1" or 2" filters. Fan performance measuring ports shall be provided on the outside of the cabinet to allow accurate air measurements of evaporator fan performance without removing panels or creating air by-pass of the coils. Condensate pan shall be internally sloped and conform to ASHRAE 62-89 self-draining standards. Condensate connection shall be a minimum of 1" I.D. female and be a ridged mount connection. Unit shall incorporate a fixed outdoor air damper with an outdoor air intake opening covered with a bird screen and a rain hood painted to match the exterior of the unit.

### INDOOR (EVAPORATOR) FAN ASSEMBLY

Fan shall be a belt drive assembly and include an adjustable-pitch motor pulley. Job site selected (B.H.P.) brake horsepower shall not exceed the motors nameplate horsepower rating, plus the service factor. Units shall be designed not to operate above service factor. Fan wheel shall be double-inlet type with forward-curved blades, dynamically balanced to operate smoothly throughout the entire range of operation. Airflow design shall be constant air volume.

A variable air volume (VAV) option using a variable frequency drive (VFD) is available for applications requiring a constant supply duct static pressure. Units equipped for VAV shall be controlled by a duct pressure transducer with a 0 - 5" WC pressure range. The pressure transducer shall provide a 0 - 5 VDC output signal to a VAV control board which, in turn shall provide a 2 - 10 VDC speed reference signal to the VFD. The VAV control board shall operate using factory-installed Supply Air, Return Air and Outside Air Temperature Sensors.

Units equipped with VFD's shall have factory-installed manual bypass as an option.

### OUTDOOR (CONDENSER) FAN ASSEMBLY

The outdoor fans shall be of the direct-driven propeller type, discharge air vertically, have aluminum blades riveted to corrosion resistant steel spider brackets and shall be dynamically balanced for smooth operation. The 4 outdoor fan motors shall be totally enclosed with permanently lubricated bearings, internally protected against overload conditions and staged independently.

### REFRIGERANT COMPONENTS

Compressors:

- a. Shall be Scroll compressors internally protected with internal high-pressure relief and over temperature protection.
- b. Shall have internal spring isolation and sound muffling to minimize vibration and noise, and be externally isolated on a dedicated, independent mounting.

Coils:

- a. Evaporator and condenser coils shall have aluminum plate fins mechanically bonded to seamless internally enhanced copper tubes with all joints brazed. Special Phenolic coating shall be available as a factory option.
- b. Evaporator and Condenser coils shall be of the direct expansion, draw-thru, design.

Refrigerant Circuit and Refrigerant Safety Components shall include:

- a. Balance-port thermostatic expansion valve with independent circuit feed system.
- b. Filter drier/strainer to eliminate any moisture or foreign matter.
- c. Accessible service gage connections on both suction and discharge lines to charge, evacuate, and measure refrigerant pressure during any necessary servicing or troubleshooting, without losing charge.
- d. The refrigeration system shall provide at least 15° F of sub-cooling at design conditions.
- e. All models shall have two independent circuits.
- f. Hot gas bypass option shall be factory-installed on compressor #1 discharge line to provide cooling in low-load applications. HGBP shall be a standard feature on VAV models and an optional feature on CV models.

### UNIT CONTROLS

- a. Unit shall be complete with self-contained low-voltage control circuit protected by a resettable circuit breaker on the 24-volt transformer side.
- b. Unit shall incorporate a lockout circuit which provides reset capability at the space thermostat or base unit, should any of the following standard safety devices trip and shut off compressor.
  1. High-pressure switch.
  2. Freeze-protection thermostat, evaporator coil. If any of the above safety devices trip, a LED (light-emitting diode) indicator shall flash a diagnostic code that indicates which safety switch has tripped.
- d. Unit shall incorporate "AUTO RESET" compressor over temperature, over current protection.
- e. Unit shall operate with conventional thermostat designs and have a low voltage terminal strip for easy hook-up.
- f. Unit control board shall have on-board diagnostics and fault code display.
- g. Standard controls shall include anti-short cycle and low voltage protection, and permit cooling operation down to 0 °F.
- h. Control board shall monitor each refrigerant safety switch independently.
- i. Control board shall retain last 5 fault codes in non volatile memory, which will not be lost in the event of a power loss.

### GAS HEATING SECTION (J\*\*DJN MODELS)

Shall be designed with induced draft combustion with post purge logic and energy saving direct spark ignition, redundant main gas valve. Ventor wheel shall be constructed of stainless steel for corrosion resistance. The heat exchanger shall be of the tubular type, constructed of T1-40 aluminized steel for corrosion resistance and allowing minimum mixed air entering temperature of 25° F. Burners shall be of the in-shot type, constructed of aluminum coated steel and contain air mixture adjustments. All gas piping shall enter the unit cabinet at a single location through either the side or curb, without any field modifications. An integrated control board shall provide timed control of evaporator fan functioning and burner ignition. Heating section shall be provided with the following minimum protection:

- a. Primary and auxiliary high-temperature limit switches.
- b. Induced draft motor speed sensor.
- c. Flame roll out switch (automatic reset).
- d. Flame proving controls. Unit shall have two independent stages of capacity.

### ELECTRIC HEATING (J\*\*DJC/E MODELS)

Nickel chromium electric heating elements shall be provided as required by the application with 1 or 2 stage control, as required, from 13.5 KW to 72 KW capacities. The heating section shall have a primary limit control(s) and automatic reset to prevent the heating element system from operating at an excessive temperature. Units with Electric Heating shall be wired for a single point power supply with branch circuit fusing (where required).

### UNIT OPERATING CHARACTERISTICS

Unit shall be capable of starting and running at 125° F outdoor temperature, exceeding maximum load criteria of ARI Standard 340/360. The compressor, with standard controls, shall be capable of operation down to 25° F outdoor temperature. Accessory low ambient kit shall be available for operation to 0° F. Unit shall be provided with fan time delay to prevent cold air delivery before heat exchanger warms up (Gas heat only).

### ELECTRICAL REQUIREMENTS

All unit power wiring shall enter unit cabinet at a single factory provided location and be capable of side or bottom entry, to minimize roof penetrations and avoid unit field modifications. Separate side and bottom openings shall be provided for the control wiring.

### STANDARD LIMITED WARRANTIES

- Compressor 5 Years
- Heat Exchanger 10 Years
- Electric Heat Element 5 Years
- Other Parts 1 Year

**OPTIONAL OUTDOOR AIR** (Shall be made available by either/or):

- **ELECTRONIC ENTHALPY AUTOMATIC ECONOMIZER** - Outdoor and return air dampers that are interlocked and positioned by a fully-modulating, spring-return damper actuator. The maximum leakage rate for the outdoor air intake dampers shall not exceed 2% when dampers are fully closed and operating against a pressure differential of 0.5 IWG. A unit-mounted potentiometer shall be provided to adjust the outdoor and return air damper assembly to take in CFM of outdoor air to meet the minimum ventilation requirement of the conditioned space during normal operation. During econo-

mizer operation, a mixed-air temperature control shall modulate the outdoor and return air damper assembly to prevent the supply air temperature from dropping below 55°F. Changeover from compressor to economizer operation shall be provided by an integral electronic enthalpy control that feeds input into the basic module. The outdoor intake opening shall be covered with a rain hood that matches the exterior of the unit. Water eliminator/filters shall be provided. Simultaneous economizer/compressor operation is also possible. Dampers shall fully close on power loss.

- **BAS-READY ECONOMIZER** - Outdoor and return air dampers that are interlocked and positioned by a fully-modulating, spring return damper actuator. The maximum leakage rate for the outdoor air intake dampers shall not exceed 2% when dampers are fully closed and operating against a pressure differential of 0.5 IWG.

For units with optional VAV control, free-cooling shall be available while the outdoor dry bulb temperature (OAT) remains below a programmable set-point of the controller. Field-installed humidity sensors for either outdoor air or outdoor & return air streams are available to provide free-cooling based on single-enthalpy or dual-enthalpy configurations, respectively. If free-cooling is available, a call for cooling shall modulate the economizer in order to maintain a supply air temperature (SAT) programmable set-point. With the use of a field-installed indoor air quality sensor, the controller shall provide Demand Ventilation by modulating the economizer dampers to allow more outside airflow upon detection of elevated indoor CO2 concentrations above a programmable set-point. With an additional field-installed outdoor air quality sensor, Differential Demand Ventilation shall be provided.

The outdoor intake opening shall be covered with a rain hood that matches the exterior of the unit. Water eliminator/filters shall be provided.

Simultaneous economizer/compressor operation is also possible. Dampers shall fully close on power loss.

- **MOTORIZED OUTDOOR AIR DAMPERS** - Outdoor and return air dampers that are interlocked and positioned by a 2-position, spring-return damper actuator. The maximum leakage rate for the outdoor air intake dampers shall not exceed 2% when dampers are fully closed and operating against a pressure differential of 0.5 IWG. A unit-mounted potentiometer shall be provided to adjust the outdoor and return air damper assembly to take in the design CFM of outdoor air to meet the ventilation requirements of the conditioned space during normal operation. Whenever the indoor fan motor is energized, the dampers open up to one of two pre-selected positions - regardless of the outdoor air enthalpy. Dampers return to the fully closed position when the indoor fan motor is de-energized. Dampers shall fully close on power loss.

## OTHER PRE-ENGINEERED ACCESSORIES AVAILABLE

- **ROOF CURB** - 14" high, full perimeter curb with wood nailer (shipped knocked-down).
- **100% BAROMETRIC RELIEF DAMPER** - Contains a rain hood, air inlet screen, exhaust damper and mounting hardware. Used to relieve internal air pressure through the unit.
- **PROPANE CONVERSION KIT** - Contains new orifices and gas valve parts to convert from natural to L.P. gas. One per unit required.
- **HIGH ALTITUDE - NATURAL GAS** - Contains orifices required for applications between 2000 and 6000 feet altitude.
- **HIGH ALTITUDE - PROPANE GAS** - Contains orifices required for applications between 2000 and 6000 feet altitude. Must be used with propane conversion kit.
- **BURGLAR BARS** - Designed to work with above roof curbs, depending on unit model. Fits duct openings of curb supply and return air openings.
- **SIDE DUCT FLANGE** - Supply and return air duct flanges for side duct applications. Do not use on units with power exhaust.
- **HIGH STATIC DRIVE** - Includes blower pulley and belt for higher CFM and/or static pressure requirements.
- **WOOD SKID** - Allows unit to be handled with 90" forks.
- **ECONOMIZER/MOTORIZED DAMPER RAIN HOOD (J25DJN/E/C only)** - Contains all hood panels and the hardware for assembling.
- **ANTI-RECYCLE TIMER** - Assures 5-minute off time between compressor cycles.
- **LOW AMBIENT KIT** - Provides unit cooling operation down to 0°F.
- **COIL GUARD KIT** - Guard for cooling coil.

## OTHER FACTORY INSTALLED OPTIONS

- **POWER EXHAUST OPTION** - To work in conjunction with economizers.
- **STAINLESS STEEL HEAT EXCHANGER**
- **STAINLESS STEEL DRAIN PAN**
- **TECHNICOAT PHENOLIC COATED CONDENSER AND EVAPORATOR COIL**
- **ELECTRONIC SINGLE ENTHALPY ECONOMIZER**
- **DIRTY FILTER SWITCH**
- **DOUBLE WALL**
- **PHASE MONITOR**
- **COIL GUARD**
- **POWERED GFI CONVENIENCE OUTLET**
- **NON-POWERED GFI CONVENIENCE OUTLET**
- **BAS READY ECONOMIZER (2-10 V.D.C. ACTUATOR WITHOUT A CONTROLLER)**
- **HINGED FILTER DOOR ACCESS AND TOOL FREE ACCESS PANELS**
- **HINGED TOOL FREE BLOWER, BLOWER MOTOR, FILTER AND ELECTRICAL ACCESS PANELS**
- **HIGH STATIC DRIVE**
- **2" PLEATED FILTERS**
- **4" THROW AWAY FILTERS**
- **DISCONNECT SWITCH**
- **SUPPLY AIR SMOKE DETECTOR**
- **RETURN AIR SMOKE DETECTOR**

## CONTROLS

- **JOHNSON LIGHT COMMERCIAL SYSTEM (LCCS)** - Provides rooftop system integration for LCCS single zone, change-over bypass and VAV systems.
- **JOHNSON UNT 1126 ROOFTOP CONTROLLER** - N2 protocol with air proving and dirty filter sensors. Hardware contains generic application logic; field engineering and/or modification may be required.