



**Magellan GPS
SkyNav 5000™**

USER GUIDE



Magellan Systems Corporation
960 Overland Court
San Dimas, California 91773
(909) 394-5000
FAX (909) 394-7050

22-40002-030





WARNINGS

A measure of knowledge by the user is required for proper and safe use of the **Magellan GPS SkyNav 5000™**. READ THE USER GUIDE AND WARRANTY COMPLETELY.

Use Good Judgement

This product is an excellent navigation aid, but it does not replace the need for careful orienteering and good judgement. Never rely on one device for navigating.

Use Care to Avoid Inaccuracies

The Global Position System (GPS) is operated by the U.S. Government, which is solely responsible for the accuracy and the maintenance of GPS. The government can make changes to the system that could affect the performance of GPS receivers. Such a change could require a modification to your SkyNav 5000.

Magellan Systems will notify you of the opportunity to upgrade the unit to accommodate these changes and other software upgrade opportunities if you have filled out and returned the registration card.

Accuracy can be affected by poor geometry with respect to the satellites. WHEN THE ACCURACY WARNING APPEARS ON THE SCREEN, USE THIS DATA WITH EXTREME CAUTION.



WARNING

Position fix accuracy can be affected by the periodic adjustments to GPS satellites by the U.S. Government and is subject to change in accordance with the Department of Defense Civil GPS user policy and the Federal Radionavigation Plan.

The aeronautical information that goes into SkyNav's database is reviewed and updated every 28 days; the most current data available is shipped with each unit.

The *database effectivity date* that is displayed during the Turn-On Sequence is the date upon which the database in your unit became valid. The shipped database will become less and less current with the passage of time. If you want to update the contents of your *internal* database, contact your Magellan dealer or installer. To update the datacard, contact Jeppesen Sanderson.

Magellan Systems Corporation makes every effort to ensure that the most current data is shipped with each product; we accept no responsibility for problems that may arise from using out-of-date information.

No part of this User Guide may be reproduced or transmitted in any form or by any means, electronic or mechanical, including photocopying and recording, for any purpose other than the purchaser's personal use without the written permission of Magellan Systems Corporation.

© 1994 by Magellan Systems Corporation. All rights reserved.

Revision History

Rev.	Date	Reason
0.0	07/92	Initial Release
0.1	08/92	Minor Corrections
0.2	09/92	Addition of Appendix 9
1.0	11/92	Software upgrade
1.1	03/93	Minor Corrections
1.2	04/93	Software Enhancement
2.0	06/93	Software Upgrade
3.0	06/94	Software Upgrade

Magellan™, GPS SkyNav 5000™, and SkyNav™ are the trademarks of Magellan Systems Corporation.

Part No. 22-40002-030 Software version 3.5 or higher



CONTENTS

CHAPTER 1 — INTRODUCTION

The SkyNav 5000	1-1
Packing List	1-2
Accessories	1-2

CHAPTER 2 — BASIC OPERATION



Modes	2-1
Overlay Functions	2-1
Annunciator Light	2-2
The Knobs	2-2
The Cursor	2-3
Data Entry	2-3
Selecting Options	2-4
Searching Through Database Lists	2-5



CHAPTER 3 — TURNING SKYNAV ON



CHAPTER 4 — THE MSG FUNCTION

Accessing Messages	4-1
Messages	4-2

CHAPTER 5 — THE NAV MODE

Bearing/Distance Screen	5-2
Track/XTC Screen	5-4
Present Position Screen	5-5
Altitude Screen	5-6
Computed Altitude	5-6
Encoder Altitude	5-6
Fixed Altitude	5-7
Time Screen	5-8

CHAPTER 6 — THE DATABASE MODE



Database Categories	6-1
Selecting a Category	6-2
Selecting a Waypoint	6-2
Viewing a Waypoint	6-3
Custom Comments	6-4
Adding a Custom Comment	6-4
Editing or Deleting a Custom Comment	6-4
Entering Waypoints	6-5
Adding a User-Defined Waypoint	6-6
Deleting a User-Defined Waypoint	6-7
Editing a User-Defined Waypoint	6-8
Saving a Position as a Waypoint	6-8





CHAPTER 7 — THE FLIGHT PLAN (FPL) MODE

Flight Plan Mode Functions	7-1
Selecting a Flight Plan Record	7-2
Examining a Flight Plan Record	7-2
Activating a Flight Plan	7-3
Selecting a Leg	7-3
Reversing a Flight Plan	7-4
Deleting a Flight Plan	7-5
Using the "edit?" Option	7-5
Inserting a Waypoint	7-5
Deleting a Waypoint from a Flight Plan	7-6
Creating a Flight Plan	7-7



CHAPTER 8 — THE AUX MODE

sats? Function	8-1
Receiver Performance	8-1
GPS Mode	8-3
Mask Angle Mode	8-4
Receiver Activity	8-4
Satellite Data	8-5
Satellite Windows	8-5
Auto-Locate	8-7
units? Function	8-8
CDI Scale	8-9
Unit of Measure	8-9
Altitude Units	8-9
Time Zone	8-11
Magnetic Variation	8-11
Turn-On Comment	8-12



Data Port Configuration	8-12
Map Datum	8-13
Altimeter Settings	8-14
Lighting Level	8-15
Emergency Start	8-15
↓ timer Function	8-16
stopwatch? Function	8-16

CHAPTER 9 — THE EMG MODE

CHAPTER 10 — THE DIRECT-TO FUNCTION

CHAPTER 11 — OPERATING CONCERNS



Determining the Quality of a Fix	11-1
Geometric Quality	11-1
Dated Information	11-2
Initialization Error	11-3
Turning the Unit Off	11-4
Selecting a GPS Mode	11-5
Using SkyNav Near the Poles	11-6
External Annunciators (optional)	11-6
Troubleshooting	11-6
When Nothing Else Works	11-10
Glossary	11-11





ILLUSTRATIONS

5-1 Flow Diagram of NAV Screens	5-1
5-2 Sample Bearing/Distance Screen	5-2
5-3 Reading the <i>CDI</i>	5-3
5-4 Sample Track/XTE Screen	5-5
5-5 Sample Present Position Screen	5-5
6-1 Sample Database Screen	6-1
6-2 Sample Waypoint Record	6-3
6-3 Sample User-Defined Waypoint	6-5
6-4 Entering a User-Defined Waypoint	6-6
7-1 Sample Header Page	7-1
7-2 Sample Flight Plan Record	7-2
8-1 Flow Diagram of sats? Screens	8-2
8-2 Sample Receiver Performance Screen	8-3
8-3 Flow Diagram of units? Screens	8-10
9-1 Sample Emergency Mode List	9-2





APPENDICES

Appendix 1

The Global Positioning System	A-1
Monitoring and Controlling GPS	A-1
How GPS Works	A-2
Accuracy	A-2
GPS Information Sources	A-3

Appendix 2

Map Datums	A-5
------------------	-----

Appendix 3

List of Datums Defined in the SkyNav 5000	A-9
-------------------------------------------------	-----

Appendix 4

Table of Constants	A-11
--------------------------	------

Appendix 5

Specifications	A-17
----------------------	------



Appendix 6

Output Data Messages	A-19
----------------------------	------



Appendix 7

ICAO Codes	A-23
------------------	------

Appendix 8

Using the External Data Card	A-27
------------------------------------	------

This chapter contains a description of the SkyNav 5000™ and the items you should find in the package. Installation instructions for the unit and the antenna are found in separate documentation.

SKYNAV 5000

SkyNav 5000 is a compact, panel-mounted, 5-channel GPS receiver that is intended for use in the general aviation VFR market. The unit was designed by engineers and pilots with the unique requirements of their fellow pilots in mind. (What GPS is and how it works is described in *Appendix 1*.)

SkyNav features UltraView™, a unique 40-character, vacuum-fluorescent display with variable illumination intensity. The vacuum-fluorescent display and optical filter combination provides an ultra-bright, crisp display with a very wide viewing angle. Information is accessed and entered by using any of the nine pushbuttons and two knobs that are positioned around the display.

SkyNav also features a built-in worldwide Jeppesen™ database, which can be expanded by the addition of front-loading database cards. The built-in database includes the coordinates of all airports with runways over 1000' in length, VORs, and NDBs. The expanded databases include additional information, such as airport VHF communication frequencies, fuel types available, ILS details, DMEs, and intersections.

In addition, SkyNav can store up to 1000 user-defined waypoints and up to 20 flight plans (with as many as 20 legs each). All user-entered waypoints and flight plans can be edited and deleted as necessary. By the press of a button, any flight plan can be reversed without re-entering any data. Features such as these make SkyNav a uniquely versatile navigation aid.

Power to operate the unit is provided by the aircraft's electrical system. The unit's memory is maintained by an internal battery. This means that SkyNav will retain all user-entered information even when it is turned off.

SkyNav can calculate and display a position with a fixed, user-entered altitude. It can also be set to display altitude data from a Magellan altitude encoder/serializer. Alternatively, SkyNav can calculate and display altitude without operator or encoder input.

SkyNav's compact design and user-friendly software means the unit is easily placed in your cockpit and easily operated. (Full specifications for the unit are in *Appendix 5*.)

PACKING LIST

When you receive your SkyNav 5000, you should have all of the following:

- Magellan SkyNav 5000 unit, 1
- installation instructions, 1
- flat patch GPS antenna, 1
- accessory pack, including 20 feet of RG-58U coaxial cable
- user guide, 1
- registration/warranty card, 1

If any of these items is missing, contact your Magellan dealer.

A database card is not included; one will be sent to you upon receipt of the registration card.

ACCESSORIES

Several accessories are available for use with the SkyNav 5000, including additional database cards and an altitude encoder/serializer. All accessories are available from your Magellan dealer.

This chapter describes the keys and knobs that control data display and data entry.

MODES

Which function the unit performs is determined by which mode is active. The unit can calculate and display navigation data (NAV); create, save, display, and manipulate flight plans (FPL); display information from an internal database or an external database card (DB); set operating and display parameters (AUX); or display as many as 30 of the waypoints that are closest to your present position (EMG).

Modes are selected by pressing one of the five keys below the display. When the key is pressed, the LED next to the key lights up, the selected mode becomes active, and the screen displays the first information screen for that mode.

In each mode, information is presented as a series of pages. Within a mode, pages are changed by turning the outer knob while the cursor is inactive. The inner knob does not function unless DB or EMG is the active mode (this is described in later chapters).

OVERLAY FUNCTIONS

Overlay functions temporarily overwrite the information displayed on the unit's screen in order to provide information required by the user, without replacing an active mode or interrupting unit operation.

There are two overlay functions. The message function (MSG) is an interface between SkyNav and the user that displays information relating to changing conditions and operating considerations the user needs to be aware of. The Direct To (D→) function allows the user to establish a one-leg route from the present

position to any waypoint; once activated, it puts the unit into the NAV mode. (Both functions are described in detail in later chapters.)

ANNUNCIATOR LIGHTS

SkyNav has eight light emitting diodes (LEDs), which indicate the current mode and the presence (and status) of messages at a glance.

Five of the annunciators are green LEDs located to the upper left of each mode button. The LED is lit steadily when the mode is active, and off when the mode is inactive. Only one mode LED can be lit at one time.

A red LED to the left of the MSG button indicates whether there are unviewed messages (flashing), viewed messages (lit steadily), or no messages (off).

Each of the two GPS mode indicators are green/red LEDs. The LED of the inactive GPS mode is off. The active GPS mode is indicated by a green LED when the receiver is tracking satellites. The LED is red when the receiver is not updating position fixes or when GQ falls to 3 or less.

You may also connect SkyNav to external annunciators. External annunciators are described in Chapter 11.

THE KNOBS

The knobs are used to scroll from one screen to another, to scroll through data lists, and to move the cursor (when active) from one space to another.

Their exact function is determined by whether or not the cursor is active.

If the cursor is inactive, the

- | | |
|------------|---------------------------------------------------|
| outer knob | scrolls from screen to screen; |
| inner knob | is inactive, unless the active mode is DB or EMG. |

If the cursor is active, the knobs are used to input data, and the

- | | |
|------------|-----------------------------------------------------------------------------------|
| outer knob | moves the cursor from one data entry position to another; |
| inner knob | scrolls through the data lists of the characters that are assigned to that space. |

THE CURSOR

The cursor is a flashing underscore that is used to enter data and to select an option or initiate a procedure. It appears only in a data entry field and under the "?" of an option. (Both data entry fields and options are discussed below.)

The cursor is toggled on and off by pressing the EDIT key. When active, it is moved from one field to another by turning the outer knob. The cursor is intelligent; it always knows what positions it can go to, whether a position is a data entry field or an option field, and what characters are appropriate for a specific data entry field.

DATA ENTRY

A data entry field is one or more spaces in which information can be entered or changed by the user. Examples of a data entry field are the name of a manually entered waypoint and a comment page.

Data can be entered only into a data entry field, and only when the cursor is active.

Each space in a data entry field has an assigned list of alphanumeric characters that are appropriate to that space. For example, letters are not available for spaces where position coordinates will be entered.

To enter data, turn the inner knob to scroll through the characters for the first space. When the desired character is displayed, turn the outer knob to move the cursor to the next space.

Each list also includes a default character, which is automatically inserted when an entry field is left blank and ENTER is pressed. (It is possible to enter a default character by scrolling through the character list, but automatic entry is much faster and easier.)

There are three possible default characters; "A", "0", and a blank space. Which one is used is determined by the type of information that can be entered into a specific data entry field. "A" is the default character in a waypoint ident entry field (idents may not contain blank spaces). In a position coordinate, all empty spaces are replaced with "0" when ENTER is pressed. This means that position coordinates with leading or trailing zeros can be entered quickly by leaving the spaces blank and allowing the unit to insert the zeros automatically. The default character in text fields such as comment pages is a blank space.

If a mistake is made, move the cursor under the error and re-enter the data. If more than a few characters must be replaced, pressing EDIT will de-activate the cursor and restore the display to its original values.

When data entry is complete, press ENTER. This will store the information entered and turn off the cursor.

SELECTING OPTIONS

Options are the words followed by a question mark that sometimes appear on the display. An option indicates that a choice must be made between the selections shown or an option approved to start a procedure.

An option is selected or approved by activating the cursor and moving it to the appropriate question mark. Press ENTER to

accept the selected option. The cursor will turn off and the unit will display the first screen of the selected option.

```
Satellite Data...
view?
```

To continue without selecting or approving an option, leave the cursor off and use the outer knob to move to the next screen.

SEARCHING THROUGH DATABASE LISTS

The cursor is also used to scroll through the database lists in the Database mode and in the Flight Plan mode.

A data list search is confined to the active database category, starting with the displayed waypoint.

A search is conducted in an edit window, which is identified by angled brackets on either side of the displayed waypoint. When the cursor is active outside of the search field, only the waypoint ident is displayed in the field.

```
N34°49.57' W118°49.43'
near: <POC >
```

When the cursor is moved into the search field, the field expands to include the database category.

```
N34°49.57' W118°49.43'
near: <POC apt>
```

Different waypoints are viewed by changing any character of the displayed name. The unit searches the current database to locate and display the waypoint whose name most closely matches the altered name. (This procedure is described in more detail in Chapter 6.) If more than one waypoint exists with the same name, the search field expands once again to include the ICAO region code. The other matches can be viewed by moving

the cursor to the region code and turning the inner knob. (ICAO codes are listed in *Appendix 7*.)

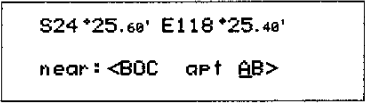

S24 *25.68' E118 *25.48'
near: <BOC aP f 8B>

You may select a different database category by moving the cursor to the category and turning the inner knob.

Once displayed, a waypoint can be accepted in two ways. You may press ENTER or move the cursor out of the edit window. Either action causes the search field to contract and display only the waypoint name.

Chapter 3

TURNING SKYNAV ON

SkyNav is turned on and off by pressing the PWR button. When first turned on, the unit enters a turn-on sequence. The first screen displayed in the sequence is a software copyright page.

```
Copyright 1993
MAGELLAN Corp.
```

This is quickly followed by a software version page,

```
MAGELLAN SkyNav GPS
SW ver: 4.0
```

an initializing database page,

```
INITIALIZING DB
DATA...
```

and then by the initial position page.

```
N34°49.57' W118°49.43'
near: <POC >
```

The lat/long position displayed is the last computed position (before the unit was turned off); the waypoint is the airport that is closest to that position. This screen is displayed for five seconds, during which time the position can be edited or a different waypoint selected.

Theoretically, it is possible to edit the first and second lines to display widely separated positions. Since the initial position should be within 500 miles of your actual location, SkyNav assumes that the position displayed on the first line is the initial position. If the last edit made was to the waypoint, however, the

new waypoint is assumed to be the initial position; this change will be reflected in the displayed lat/long.

After five seconds with no data entry or after data entry is complete, the last known altitude is displayed.

```
Present altitude
          997'
```

This screen is also displayed for five seconds. If correct, do not make any changes.

When data entry or the five-second display is complete, the current date and time are displayed. Once again, this screen is displayed for five seconds, during which the information displayed can be updated.

```
date: 25-NOV-93
time: 12:38 LOCAL
```

All initialization information is accepted once the date and time are updated or the five-second delay is complete. The receiver now has all required initialization information.

After a few seconds, the turn-on sequence continues with current database information, including the database's date of effectivity.

```
DB : Internal/World
DATE: 07-JUL-94
```

The database screen is followed by a user comment screen, which is blank unless text is entered with the AUX mode.

```
OIL CHANGE DUE IN
3 HOURS !      ok?
```

When "ok?" is accepted (by pressing ENTER), SkyNav automatically enters the NAV mode and starts to obtain positioning information.

If SkyNav has no almanac or if the initial position has never been set (since leaving the factory), the unit automatically begins Sky Search.

Searching the sky...

Sky Search is the part of the Almanac Collect and Auto-Locate procedures in which the receiver searches the sky for satellites until enough are located for a position fix. Sky Search usually lasts from 12 to 15 minutes. (It is described in detail in Chapter 11.) Operator response is not required to initiate Sky Search; the message is displayed for a few seconds to advise the user that Sky Search has started.

NOTE

SkyNav receives updated almanac information while it is tracking satellites. If the unit is in regular, sustained use (15 minutes or more) and initialization is correct, Sky Search should be unnecessary.

SkyNav now displays the first NAV screen as it begins acquiring satellites to obtain its first position fix.



Turning SkyNav On

SkyNav 5000



3-4



SkyNav generates messages as required to provide operational information and warnings to the user. These messages are retained as long as they are valid, and are then automatically deleted. The presence of messages and whether or not they have been viewed is indicated by the LED to the left of the MSG button.

When the LED is:

OFF	There are no messages
FLASHING	There is at least one unviewed message
ON	There are no unviewed messages, and at least one viewed message

ACCESSING MESSAGES

MSG displays messages and warnings as an overlay to the current screen. When the overlay is cancelled, the active screen is restored.

To view the messages, press the MSG button. The first overlay screen displays the number of currently valid messages. (Invalid messages do not relate to current conditions and are not retained.) Messages are classified as being new (not viewed) or old (viewed).

```
MSG:  1 new  3 old
      Turn outer knob...
```

Turn the outer knob clockwise to view the messages. The most recent message is displayed first, and the oldest message is displayed last. Once viewed, most new messages become old messages, and are retained until no longer valid. Messages relating to navigation conditions are usually discarded as soon as they have been viewed.

Press the MSG button to turn the MSG display off.

MESSAGES

The following is a list of messages that SkyNav may generate.

Condition: Within 1 minute computed flying time of
turn point

Cleared by: Leg sequencing or exceeding 1 minute to
turn point

Message:

Prepare for turn
Next track is 057°

Condition: Time to turn; seen when FPL mode is
MANUAL

Cleared by: Viewing

Message:

Time to turn
Next track is 057°

Condition: Commencing a flight plan leg when the
following leg is less than two nautical
miles in length

Cleared by: Leg sequencing

Message:

CAUTION:
Next leg very short

Condition: GPS receiver operation in 2D mode. This message is reactivated every 10 minutes.

Cleared by: Viewing window
OR
3D position solution

Message: REMINDER: Using 2D
check altitude!

Condition: GPS receiver operation in auto mode has reverted from 3D to 2D

Cleared by: Restoration of 3D mode, or mode change, or viewing

Message: Too few sats for 3D!
Now using 2D

Condition: Only three satellites available when in 3D mode

Cleared by: Four or more satellites becoming available, or mode change to 2D or AUTO

Message: Too few sats for 3D!
Try 2D or AUTO

Condition: Fewer than three satellites available for navigation

Cleared by: Three or more satellites becoming available

Message: Too few sats in view
for position fix!

Condition: GQ is 3 or less
Cleared by: GQ becoming 4 or more
Message:

If in 3D:

WARNING: GQ = 3 ! Try 2D

If in 2D:

WARNING: GQ = 3 !

Condition: Position is assessed as being invalid, or SkyNav 5000 is not updating

Cleared by: Position being assessed as valid

Message:

WARNING! Position fix not updating!

Condition: Receiver is updating, but estimated fix error > 0.5 nm

Cleared by: Position being assessed as valid

Message:

WARNING! Estimated fix error over 0.5 nm

Condition: Altitude encoder input was selected in AUX and no input is being received.

Cleared by: Receipt of encoder input or selection of a different altitude input (in AUX)

Message:

Altitude encoder reports error

Condition: Outside of the encoder/converter's operating range. The Magellan encoder/converter operates between -1000 feet and 35,000 feet (-304.8 and 10,760.7 meters).

Cleared by: Moving into the encoder/converter's operating range.

Message:

Altitude encoder out of range

Condition: Altitude encoder/converter has not reached operating temperature

Cleared by: Altitude encoder/converter reaching operating temperature.

Message:

Altitude encoder not ready

Condition: Hardware problem internal to the altitude encoder/converter.

Cleared by: Non-recoverable error. Operate with computed altitude or fixed altitude until encoder/converter can be checked.

Message:

Altitude encoder hardware error



The MSG Function

SkyNav 5000

Condition: Receiver position has updated by
greater than .5 NM between fixes.

Cleared by: Position being assessed as valid

Message:

**WARNING: POSITION
JUMP over .5ⁿ**



The NAV mode provides access to all navigation information. This includes position, altitude, cross-track error, bearing, distance, and time to the next waypoint (if a flight plan or Direct-To is active).

If timer output has been redirected, NAV displays the countdown timer or the stopwatch beside the navigation information. (This is described in Chapter 8.)

There are five principal NAV screens. Each is described separately below. Figure 5-1 shows the sequence in which these screens are displayed.

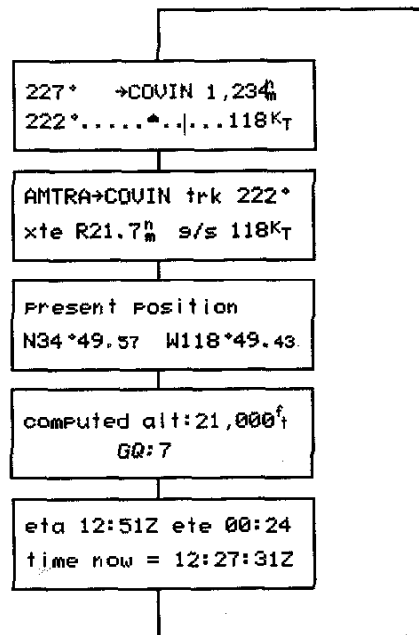

*There are three possible altitude screens; which is displayed is determined by the active GPS mode and altitude input that was selected in the AUX mode.

Figure 5-1. Flow Diagram of NAV Screens

Once the turn-on sequence is complete, SkyNav automatically enters the NAV mode. NAV can be deactivated at any time by selecting another mode and can be reactivated by pressing the NAV button.

The NAV mode automatically becomes the active mode when a Direct-To track is established and approved (with the \rightarrow button). It is not necessary to activate the NAV mode manually.

BEARING/DISTANCE SCREEN

Bearing and distance to the destination waypoint is displayed on the first screen.

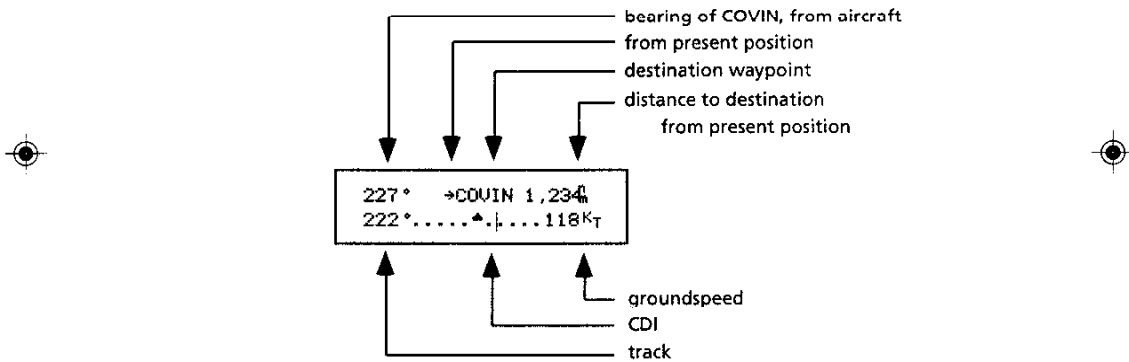

Figure 5-2. Sample Bearing/Distance Screen

The "→" symbol is displayed unless you are on a Direct-To track. If you are on a Direct-To track, "→" is replaced by the symbol "→", which remains on the first NAV display until the leg's destination is reached.

The countdown timer or stopwatch output replaces ground-speed when the "load?" option is selected in AUX. The destination waypoint, cross-track deviation indicator, bearing, track, and distance are unaffected by these conditions.

Distance is the distance between the present position and the destination waypoint displayed. (The units are selected in AUX.) The values displayed for track and groundspeed are current values that are based on data collected in the last few seconds.

All flight plan related data is replaced with dashes when there is no active flight plan, when Direct-To is inactive, and when the unit has not obtained a position fix since power-on or flight plan activation. Track and groundspeed are replaced with dashes when SkyNav has not yet obtained a position fix or speed falls below 1 knot.

The cross-track deviation indicator (CDI) on the second line of the display is a graphic representation of the cross-track error (a numeric value is displayed on the next screen). It includes scale markers, a course needle, and a fixed aircraft symbol.

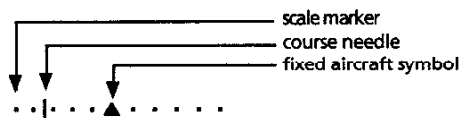

Figure 5-3. Reading the CDI

The aircraft is represented by a triangle, which is fixed in the center of the display. The triangle also indicates movement toward or away from the destination waypoint. A ▲ indicates that the distance to the destination is decreasing. A ▼ indicates that the distance between the present position and the destination waypoint is increasing.

The TO/FROM flag on a conventional CDI is position-based; it indicates whether you are on the "To" or "From" side of a beacon. SkyNav's TO/FROM flag generally agrees with the flag of a conventional CDI, but will occasionally differ.

NOTE

SkyNav's TO/FROM flag tells you whether you are **actually moving to or from** the waypoint.

Distance away from the track is indicated by scale markers on either side of the aircraft symbol (▲). The user selects both the unit of measure used by the CDI (nautical miles, statute miles, or kilometers), and how many units or fractions of units are represented by each marker. The default setting is one full unit of measure per marker; the CDI displays cross-track error up to five units on either side of track when using the default scale. Both the unit of measure and the CDI scale are selected in AUX units?

The SkyNav CDI follows aviation convention in displaying cross track error in relation to the planned track, *not* in relation to which way the aircraft is pointing. If you are to the left of the track, the course needle is to the right of the aircraft symbol regardless of whether the aircraft is heading directly to the destination waypoint or away from it. (Refer to Figure 5-3. The CDI illustrated shows the aircraft to the right of the course.) The CDI is an indication of relative position, not of heading.

During navigation, the course needle moves to show the amount of the cross-track error. If there is no cross-track error information available, (e.g., flying an undefined route) the needle is not displayed.

TRACK/XTE SCREEN

The second screen displays track, cross-track error, ground-speed, and the start/destination waypoints of the current leg. (When on a Direct-To track, \oplus is displayed instead of "→".) If there is no active flight plan, Direct To is not active, or SkyNav has not obtained a position fix since power-on or flight plan activation, all displays except track and ground-speed are filled with dashes.

Cross-track error is preceded by an "L" or "R" to indicate if the aircraft is to the left or right of the planned track; blank is shown if the aircraft is on track. When XTE exceeds 99.9 units, "100+" is displayed.

Track and groundspeed correspond to the last position update. If SkyNav has not yet obtained a position fix, dashes are displayed for track and groundspeed; dashes are also displayed when groundspeed is less than 1 knot. If SkyNav is not updating its position the most recent information available is displayed, a warning message is generated, and the mode and message LEDs flash. The information displayed may not correspond with the current aircraft track and groundspeed, and should therefore be used with care.

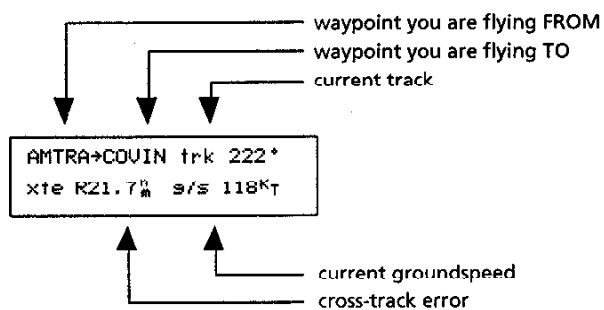

Figure 5-4. Sample Track/XTE Screen

PRESENT POSITION SCREEN

The third screen displays the present position of the aircraft. It is most often used when monitoring your progress in relation to a boundary that is defined by latitude/longitude, and when reporting your position to the air traffic controller or another aircraft when there is no convenient aeronautical reference.

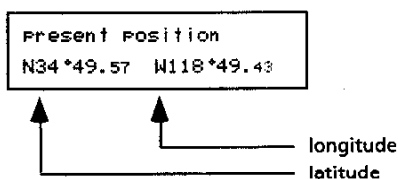

Figure 5-5. Sample Present Position Screen

ALTITUDE SCREEN

The fourth screen displays altitude information. The altitude displayed is: a user-entered value, a value that is computed by SkyNav, or an input from an altitude encoder. Which type of altitude information is displayed is determined by the current GPS mode and whether an altitude encoder is on-line. (Mode and dataport configuration for encoder input are selected in the AUX mode.)

Computed Altitude. When SkyNav is operating in the 3D GPS mode (refer to *Chapter 11* as required during the following discussion), it *calculates* altitude above sea level when position is computed. This is referred to as the *computed altitude*. This altitude is derived solely from satellite information.

```
computed alt: 21,000';  
G0: 9
```

NOTE

The computed altitude may be subject to rapid and significant variations, and may also vary significantly from pressure altitude. It should never be used or relied on for vertical navigation or terrain clearance.

Encoder Altitude. SkyNav displays altitude information supplied by an external altitude encoder when:

1. it is operating in the 2D GPS mode and is producing position fix updates
2. the unit has been connected to an altitude encoder
3. encoder input through the dataport was enabled in the units? function of the AUX mode

Encoder altitude is the aircraft's altitude above sea level (as determined by the encoder). An encoder always outputs altitude referenced to 29.92 in/1013 mb. In order to convert

encoder output to height above mean sea level, the local barometric (altimeter) pressure setting for the encoder must be entered on the second line of the screen below. The altimeter setting must be entered here **regardless** of whether the aircraft's main altimeter is referenced to flight levels or to height above mean sea level in order to obtain the most accurate position fixes.

```
encoder alt:21,000',
altimeter :29.88 in
```

The altimeter setting can be changed at any time when this screen is displayed. Activate the cursor and position it under the unit of measure. (Altitude is displayed as dashes while the cursor is active.) Turn the inner knob until the desired value is displayed, then press ENTER. SkyNav redisplay the altitude, corrected to the new altimeter reference.

NOTE

The altitude encoder outputs information relative to the 29.92 in./1013.2 mb. It is the user's responsibility to ensure that the best available setting is used.

Fixed Altitude. Fixed altitude is displayed when the unit is operating in the 2D GPS mode and there is no encoder input. It is a manually entered altitude that must be updated periodically.

If SkyNav is **not** using fixed altitude as its reference (i.e., it is in the 3D mode or the encoder is on line), fixed altitude is updated according to the most recent computed or encoder altitude. This will ensure that you will have the best altitude information available if you revert to the 2D mode with a fixed altitude.

```
fixed alt:
21,000'
```

The displayed value of the fixed altitude can be changed manually at any time from the displayed screen (in the NAV mode) or from the GPS mode display (the second sats? screen in the AUX mode). Turn the cursor on, enter the new value, and press ENTER.

NOTE

In the 2D GPS mode, SkyNav uses the fixed altitude as part of its position determination. Therefore, when operating with fixed altitude as your reference, you will obtain the greatest accuracy from SkyNav if an accurate value for fixed altitude is entered.

In order to keep the fixed altitude current during flight, SkyNav generates a message every 10 minutes that reminds the pilot to update the altitude reference.

TIME SCREEN

The time screen shows three time measurements: estimated time of arrival, estimated time en route, and current time.

```
eta 12:51Z ete 00:24
time now = 12:27:31Z
```

Estimated time of arrival is the clock time of your expected arrival at the destination waypoint of the current leg. Estimated time en route is the length of travel time until you reach the destination waypoint. The eta and ete displays are filled with dashes if a leg or Direct-To is not active, if aircraft speed is 1 knot or less, or the aircraft is moving away from the destination waypoint.

Current time and eta are displayed with a time symbol when the time selected is UTC (Z); there is no symbol when local time is used. Which convention is used is selected in AUX.

Chapter 6

THE DATABASE MODE

The Database mode provides access to waypoint information that is stored in both the published and user-defined databases. (There are approximately 20,000 waypoints in the internal database, and as many as 1000 in the user-defined database.) The Database mode is activated by pressing the DB button.

This chapter describes the use of the Database mode with the internal database. Additional information is available when an external datacard has been installed; using the external database is described in *Appendix 8*.

When the Database mode is activated, the first screen shown is always the first page of the last waypoint displayed.

DATABASE CATEGORIES

The published and user-defined databases form one overall database, which is divided into categories. Only one category can be displayed at any time. The categories are:

apt	...	airports
vor	...	VORs
ndb	...	NDBs
usr	...	user-defined waypoints

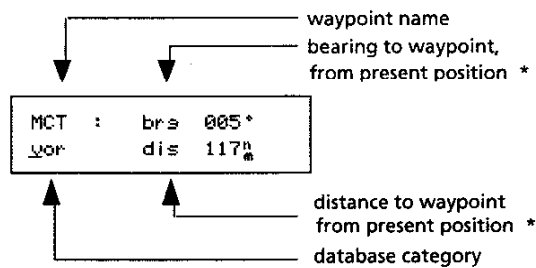

* If SkyNav is obtaining position fixes, bearing and distance are continually updated.

Figure 6-1. Sample Database Screen

(The categories "int" and "dme" are added when an external database is available. The external database is described in *Appendix 8*, which is part of the hardware upgrade option.)

Waypoints are accessed by first selecting the category, then selecting a waypoint in that category.

Selecting a Category. Position the cursor under the category name at the lower left. Turn the inner knob to scroll through the database categories.

Selecting a Waypoint. A waypoint can be retrieved in two ways; by an item-by-item search of the current category or by matching displayed characters.

An item-by-item search is done when you do not know or are unsure of the waypoint name. Turn the cursor off (by pressing EDIT), then turn the inner knob. Each time the knob is turned clockwise one notch, the display advances to the next waypoint in the category.

SkyNav can also conduct a "string search" to locate waypoints in a database category. A string search matches the characters in a displayed item that are to the left of the cursor to characters in the database. String searches provide an easy way to "jump" through the database quickly, and are usually done when all or part of the waypoint name is known.

SkyNav matches the characters that are to the left of and above the cursor, and then displays the item that follows. For example, when the waypoint displayed is "MCT" and the cursor is under the "T", SkyNav searches for the waypoint whose name starts with "MC" and follows "MCT" in the database, starting with the waypoint displayed. If a waypoint is found, the new waypoint is displayed. If no waypoint meeting these conditions is found, the unit returns to the start of the database and restarts the search. If a waypoint meeting the displayed conditions (here, where the name starts with "MC" and follows "MCT") is still not found, the display is not changed.

MCT	:	brs	005°
vor	:	dis	177"

Searches cannot be made across categories in the Database mode; to search the database in a different category, you must select a new category as described above.

Viewing a Waypoint. A waypoint and its associated information consists of a sequence of pages, which together form a *record*. The information stored within a record is grouped into three pages.

The pages of a waypoint record are displayed when the cursor is off by turning the outer knob. To turn the cursor off, press EDIT.

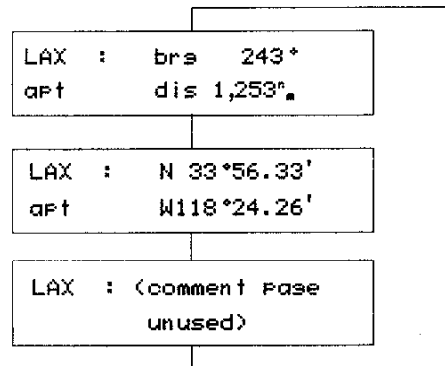

Figure 6-2. Sample Waypoint Record

The record formats for the 'vor' and 'ndb' database categories are identical with the above. A comment page is always provided; its use is optional (see below).

CUSTOM COMMENTS

A comment page can be added to as many as 500 waypoint records in any database category. (If you try to enter a comment when there is insufficient memory, the unit generates a warning

message.) Once entered, a comment page can be edited or deleted at any time.

The maximum size of a comment is 34 characters; letters, numbers, and spaces are available.

Adding a Custom Comment. A custom comment can be appended to any record that does not currently have a comment attached. To append a custom comment, select the desired record and display its third page:

```
LAX : <comment page  
      unused>
```

Press EDIT to activate the cursor and enter up to 34 characters. Press ENTER to save the entry. (A comment must consist of at least 1 character, excluding an empty space.)

Editing or Deleting a Custom Comment. An existing comment can be altered or deleted at any time. Start by displaying the comment. Press EDIT to display the edit? and delete? options.

```
User Comment:  
      edit? delete?
```

If you select the "edit?" option, the screen reformats to display the comment. The cursor is active at the top left of the screen.

Press ENTER after all changes have been made to save the edited comment.

If you select the "delete?" option, the comment is erased and the screen displays the empty comment page.

```
LAX : <comment page  
      unused>
```

ENTERING WAYPOINTS

The "usr" category contains up to 1000 user-defined waypoints. These waypoints are used and displayed in the same way as published waypoints; the only difference is the "ops?" (operations) option that appears on the first page of the waypoint record when the cursor is active.

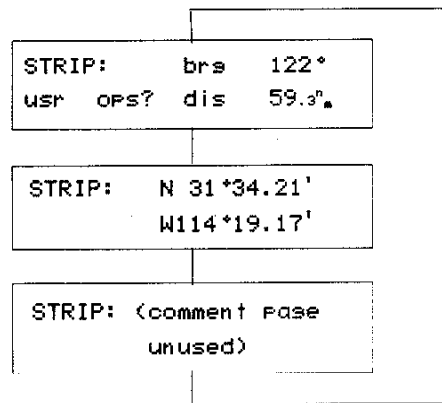

Figure 6-3. Sample User-Defined Waypoint

The "ops?" option permits the entry, editing, and deletion of waypoints. When you accept the "ops?" option, the following screen appears :

```

STRIP: edit? delete?
      add new wpt?
  
```

Adding a User-Defined Waypoint. The following screen appears when the "add new wpt?" option is taken:

```

define _____ at...
ppos? lat/long? ref?
  
```

In the screen above, the cursor is active after the word "define." Enter a waypoint name that is up to five characters long. In the samples that follow, the waypoint name is "HOUSE."

Once the name is entered, move the cursor to the bottom line and select how the waypoint coordinates will be entered. Select "ppos?" to accept the present position as the waypoint coordinates. No further entry is required. (While this is a very convenient way to enter a waypoint, the waypoint will be as accurate as the last position fix. Do not use the present position if the GQ of the fix is 3 or less.)

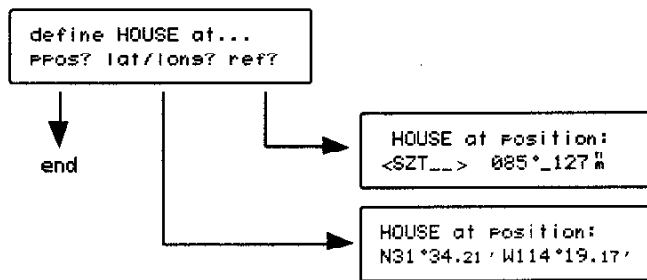

Figure 6-4. Entering a User-Defined Waypoint

If you select "lat/long?" the screen displays a blank line for you to enter the coordinates.

```

HOUSE at Position:
N__°____ W__°____
  
```

Select "ref?" if you want to define the waypoint's position in relation to its bearing and distance from the present position or another waypoint. The present position or other waypoint is the "reference" waypoint.

```

HOUSE at Position:
<BAF__ > __°____
  
```

When "ref?" is selected, the second line displays a **database search field** (defined by the angled brackets), which means that you may select a waypoint from any database category as described in *Chapter 2*. The cursor is active in the search field, and the first waypoint displayed is "ppos".

After choosing a reference position, move the cursor to the right to enter bearing and distance. Remember that you are entering bearing and distance FROM the reference waypoint TO the waypoint you are defining.

Once the waypoint name and coordinates have been entered, press ENTER to save the waypoint. The screen now re-formats and displays the first page of the newly defined waypoint record.

Deleting a User-Defined Waypoint. To delete a user-defined waypoint, first display the waypoint you want to delete, then select "ops?".

```
HOUSE: edit? delete?  
        add new wpt?_
```

When you take the "delete?" option, SkyNav asks you to confirm your request before actually making the deletion :

```
delete wpt HOUSE..  
        ok?
```

Press ENTER to delete the waypoint displayed. Press any key other than ENTER to stop the deletion procedure; press the DB button to stop the deletion procedure and return the display to the first page of the waypoint record.

NOTE

A user-defined waypoint that is being used in a stored flight plan cannot be deleted or edited. Any attempt to do so will generate a warning message. The flight plan must be deleted or edited to remove the waypoint before the waypoint can be deleted from the database or changed in any way.

Editing a User-Defined Waypoint. A user-defined waypoint can be edited to alter all or part of its positioning information. To edit a user-defined waypoint, first display the waypoint you want to edit, then select "ops?".

```
HOUSE: edit? delete?
        add new wpt?
```

Next, select "edit?".

```
Name : HOUSE
                        ok?
```

If you accept "ok?", the waypoint's coordinates are displayed and the cursor is activated. Make the necessary changes, then press ENTER to save the corrections.

SAVING A POSITION AS A WAYPOINT

The present position can also be saved as a waypoint from any NAV display.

To save a position fix as a waypoint, go to any NAV display and press ENTER, ENTER. Do nothing to use a unit-generated name; the unit will name the waypoint automatically in 4 seconds. To name the waypoint manually, press EDIT and enter a waypoint name.

A unit-generated name is a letter (starting with "P") followed by the time of the fix. A fix obtained at 20:25, then, could be named "P2025." A fix saved at the same time on another day could be "Q2025." (The unit will use P, Z, 0, 1, then A-O.) A unit-generated name can be changed at any time in the DB function.

Chapter 7 THE FLIGHT PLAN (FPL) MODE

SkyNav stores up to 20 user-defined flight plans, each containing up to 20 legs. All flight plans are created, deleted, edited, reversed, and selectively activated in the Flight Plan mode.



WARNING

Use caution when making changes of any kind to an active flight plan and when selecting a new active flight plan. If SkyNav output is being used by an autopilot, altering the active flight plan may cause large fluctuations in cross-track error to occur, which can result in significant and sudden flight path excursions. We advise you to de-couple before making any change to an active flight plan.

FLIGHT PLAN MODE FUNCTIONS

Press the FPL button at any time to activate the flight plan mode. This causes the green annunciator beside the FPL button to illuminate, and the screen to display a header page for the currently active flight plan.

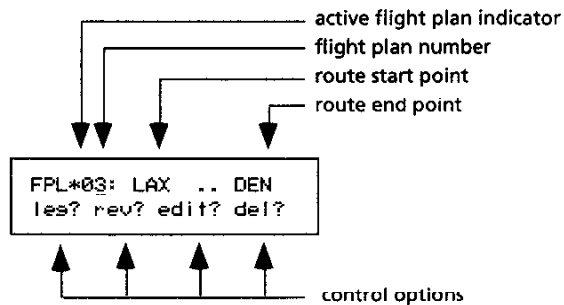

Figure 7-1. Sample Header Page

SELECTING A FLIGHT PLAN RECORD

In the screen above, the cursor is active under the flight plan number. Rotate the inner knob to scroll through the flight plans in numerical order. Note that when you move off the active flight plan, the screen is formatted slightly differently — the '*' (active flight plan indicator) disappears, and the "leg?" option becomes a "fly?" option:

```
FPL 07: MSN .. OSH
fly? rev? edit? del?
```

EXAMINING A FLIGHT PLAN RECORD

Select the desired flight plan record as described above, and switch the cursor off by pressing EDIT. Turn the outer knob to scroll through the selected flight plan record.

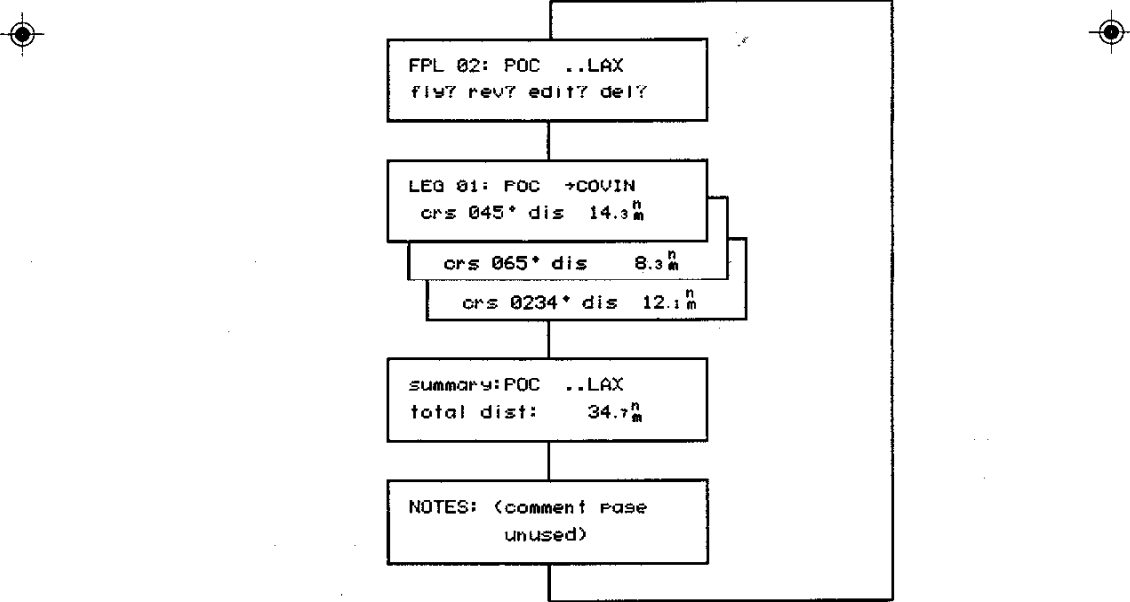

Figure 7-2. Sample Flight Plan Record

The header page has been discussed; the following pages define each leg of the flight plan. A summary page is displayed after all of the legs have been defined. The summary page tells you the total distance of the route from start to finish.

The flight plan record has an optional custom comment page, which is displayed only when text has been entered. The custom comment page for a flight plan is the same as a custom comment page for a waypoint. Refer to *Chapter 6* to enter or edit a custom comment page.

ACTIVATING A FLIGHT PLAN

There can only be one active flight plan at any time; the currently active flight plan is deactivated when another flight plan is activated. To activate an inactive flight plan, display the first page of the desired flight plan.

```
FPL 07: MSN .. OSH
fly? rev? edit? del?
```

When "fly?" is selected, the displayed flight plan is activated and the screen is reformatted to reflect the displayed flight plan's new status. The previous flight plan or Direct-To is also de-activated.

```
FPL*07: MSN .. OSH
les? rev? edit? del?
```

SELECTING A LEG

Once an active flight plan is displayed, the "fly?" option is replaced by a "leg?" option. Choose the "leg?" option to select one of the legs that were defined for the displayed flight plan.

```
LEG*03: GRB →STE
auto? use?
```

The cursor is active under the leg number, and the inner knob can be rotated to display any leg in the flight plan. Note that the '*' again indicates 'active', i.e., which leg is the active leg.

Normally, SkyNav will determine which leg you are on based on your current position. Therefore, when you arrive at (or go past) a waypoint, SkyNav will automatically select the next leg for you. This is *automatic leg selection*.

However, there may be occasions when you want to force SkyNav to use a particular leg. To do this, select the "use?" option from the screen above. This forces the displayed leg to be the active leg; it will remain active until another leg is selected. This is *manual leg selection*. To revert to automatic at any time, select the "auto?" option.

To return to the flight plan header page, just press the FPL button. To display current course and distance to the leg's destination waypoint, turn the inner knob.

```
LEG #03:GRB  a→STE a
crs 240° dis 40.2
```

REVERSING A FLIGHT PLAN

SkyNav allows you to reverse the waypoint order of the displayed flight plan. This means that you can use a flight plan on an outbound trip, reverse it, and navigate a return trip on the same flight plan.

To reverse a flight plan, select the "rev?" option.

```
FPL 07: MSN  .. OSH
fly? rev? edit? del?
```

You will notice that the 'start' and 'finish' waypoints exchange places. All of the legs of this flight plan are also reversed. This is a permanent change until the flight plan is edited or reversed again.

DELETING A FLIGHT PLAN

The "del?" option allows you to erase the displayed inactive flight plan. When a flight plan is displayed and "del?" is selected, SkyNav displays a request for confirmation.

```
FPL 02: POC ..LAX
delete FPL:      ok?
```

Confirmation is intended to prevent the accidental deletion of a potentially valuable flight plan. Approve the deletion of the displayed flight plan by pressing ENTER, or abandon the procedure by pressing any other key; either action returns the display to the flight plan header page.

USING THE "edit?" OPTION

Any flight plan can be altered by adding or deleting waypoints in the record. This is done by using the "edit?" option from the flight plan screen.

While it is possible to edit an active flight plan, doing so requires caution. Please refer to the warning on page 7-1 before editing an active flight plan.

Inserting a Waypoint. A new waypoint is added to a flight plan by accessing it from the edit window.

```
FPL 02: POC ..LAX
fly? new? edit? del?
```

Display the flight plan you want to change, and select the "edit?" option.

```
POC <AMTRAd>-LAX
insert? delete?
```

The new waypoint will be inserted **before** the waypoint that is displayed in the edit window. Scroll through the flight plan until the waypoint before which the new waypoint will be inserted is in the edit window. Activate the cursor and select "insert?". (If the flight plan already has 20 legs, selecting "insert?" generates a "current FPL is full" display.)

```
POC <COVIN aP+>-AM
```

SkyNav moves the waypoint in the edit window to the right, and displays the last-viewed waypoint and database category in the window. (The country code will also be displayed if there is more than one waypoint with the same name in the current category.) If there is room on the display, part of the moved waypoint's name will be shown.

Use the inner and outer knobs to display the desired category and waypoint. To accept the displayed waypoint/category, either move the cursor out of the edit window or press ENTER. The waypoint in the edit window is entered into the flight plan, the screen re-formats to the normal flight plan edit screen.

```
FPL 02: POC ..LAX
fly? rev? edit? del?
```

Deleting Waypoints From a Flight Plan. Any waypoint can be deleted from a flight plan. This is done by locating the waypoint that will be deleted, and then erasing it from the flight plan. Start by displaying the flight plan you want to edit.

```
FPL 02: POC ..LAX
fly? rev? edit? del?
```

Select the "edit?" option. (Selecting the "del?" option will delete the entire flight plan.)

```

<PUC >-COVIN
insert? delete?

```

The first two waypoints of the flight plan are displayed. Turn off the cursor, then turn the outer knob until the waypoint you want to delete is in the edit window.

```

POC <COVIN>-AMTRA
insert? delete?

```

Select "delete?". You are asked to confirm that you really want to delete this waypoint.

```

POC <COVIN>-AMTRA
delete wpt: yes? no?

```

Select "yes?" to remove the waypoint from the flight plan. Select "no?" to stop deletion and keep the waypoint in the flight plan.

```

FPL 02: POC ..LAX
fly? rev? edit? del?

```

It is possible to delete all of the waypoints in a flight plan in this way, but if you really want to delete a flight plan, it is much faster to select "del?" instead of "edit?". Remember that a flight plan requires at least two waypoints; any flight plan that has fewer than two waypoints when editing is completed will be regarded as empty.

CREATING A FLIGHT PLAN

A flight plan can be created only when an empty record is available. To create a flight plan, first display the header page of an empty record.



The Flight Plan Mode

SkyNav 5000

```
FPL 01:  <empty>
fly? rev? edit? del?
```

Take the "edit?" option, and use the procedure described in *Adding a Waypoint* to insert waypoints into the (empty) flight plan. As long as at least two waypoints are entered before exiting the flight plan record, the flight plan will be saved automatically.



The AUX mode provides access to several functions that are not used frequently. These functions are satellite information and control, unit default settings, countdown timer operation, and stopwatch operation.

The AUX mode is selected at any time by pressing the AUX button below the display. When AUX is pressed, the green annunciator light beside the button illuminates to indicate that the AUX mode is now active.

The first screen displayed when AUX is pressed is the *AUX Main Menu*. Move the cursor (with the outer knob) until it is below the desired selection. Press ENTER.

```
sats? units? card?*  
↓timer? stopwatch?
```

* card? is operational with expanded database card only.

sats? FUNCTION

The sats? function presents a sequence of screens that relate to satellite information and control. This includes the GPS mode that is being used, satellite schedules, and receiver activity.

Receiver Performance. The receiver uses five channels operating simultaneously to locate and track satellites. This screen monitors the activity on all five channels.

The first line of the screen identifies the satellites the receiver is searching for or tracking. The second line displays the status of the search and acquisition.

Ephemeris data is precise positioning information; since the satellites are in constant motion, ephemeris data must be

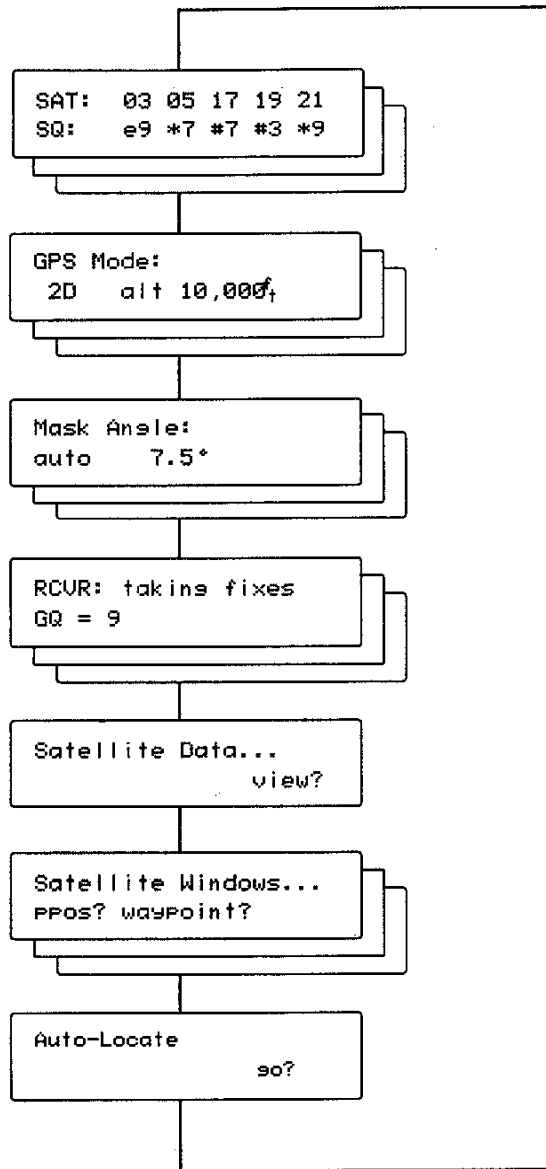

Figure 8-1. Flow Diagram of sats? Screens

continually updated. SkyNav retains ephemeris data for two hours (even when the unit is off), after which the data is no longer current. If SkyNav takes position fixes and is turned off, then is turned back on within two hours, the unit will probably still have ephemeris data for at least one of the satellites that will be used in the position fix.

If the receiver is unable to locate some of the satellites displayed, they will be replaced by others. If you observe this screen over a period of time, you will probably see the receiver changing satellites until it has acquired enough satellites for a position fix in the GPS mode you selected.

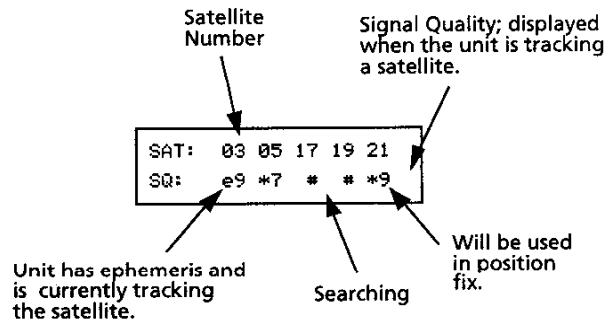
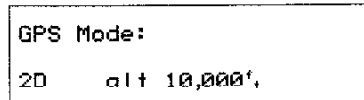

Figure 8-2. Sample Receiver Performance Screen

GPS Mode. This screen displays the current GPS mode. SkyNav has three GPS modes: 2D, 3D, and AUTO. Activate the cursor, then turn the outer knob until the desired GPS mode is displayed. (GPS modes are described in Chapter 11.)



If 2D or AUTO are selected, you should also enter a fixed altitude. Move the cursor to the right and enter an altitude.

Press ENTER to store the value entered for altitude, then turn the outer knob to continue to the next screen.

Mask Angle Mode. The mask angle is the angle above the horizon below which the receiver will not search for satellites. In general, a higher mask angle is used when the surrounding area includes objects that could block satellite signals; a lower mask angle is used when the view of the sky has few obstructions.

SkyNav has an automatic and a manual mask angle mode. When "auto" is selected, the mask angle is 7.5°

```
Mask Angle:  
auto
```

When the manual mask angle mode is selected, you may enter any mask angle between 0° and 30°.

```
Mask Angle:  
manual 5°
```

The mask angle entered here remains effective until a new value is entered or the mask angle mode is changed to auto.

With the cursor off, turn the outer knob to move to the next screen.

Receiver Activity. The receiver activity screen displays the current operational status of the receiver (searching for satellites, taking fixes, etc.). If fixes are currently being taken, the display also includes the geometric quality (GQ) of the current fix.

```
RCVR: taking fixes  
GQ = 9
```

Satellite Data. Satellite data includes the relative position and signal quality of the healthy satellites in the GPS constellation. This screen can also be used to force the receiver to ignore a satellite by turning it "OFF."

The first satellite data page is inactive, which gives the user the opportunity to continue scrolling to the satellite windows function without accessing satellite data.

To view satellite data, activate the cursor under "view?", then press ENTER.

```
Satellite Data...
                view?
```

Turn the inner knob to scroll through the data for successive satellites. Bearing and elevation is displayed when the satellite is above the horizon. If the satellite is being tracked, the SQ (Signal Quality; described in Chapter 11) is also displayed.

```
SAT 06:   brs 245°
ON  SQ=9  elev 003°
```

A satellite is either "ON" or "OFF," which means that the receiver will either include this satellite in its search pattern or ignore it. A satellite is always "ON" unless the user has turned it off.

Once turned off, a satellite remains off until it is turned back on by the user. A satellite should not be turned off unless the unit is consistently unable to locate it when satellite data and satellite windows indicate that the satellite should be visible. It should be turned back on before the unit is used again.

Satellite Windows. Satellite windows are the times when enough satellites will be visible, given the GPS mode, date and position entered, to obtain a position fix. Windows of availability are calculated for a 24-hour period.

There are enough satellites in orbit to provide 2D or 3D satellite coverage in most parts of the world. (Refer to *Appendix 1* for a discussion of GPS and satellite coverage.)

Satellite availability is determined for a present position or for a specified waypoint. Select "ppos?" or "waypoint?".

```
Satellite Windows...
PPOS? WAYPOINT?
```

The following screen is displayed if you select "ppos?".

```
2D Windows 25-NOV-92
PPOS:                ok?
```

SkyNav also displays the current GPS mode and date. Move the cursor from field to field as required to enter a new GPS mode (select 2D or 3D) and date. When ready, move the cursor to "ok?" and press ENTER.

If "waypoint?" is selected, the last-viewed airport waypoint in the database is displayed along with the current GPS mode and date. Make any necessary changes to the mode and date, and select a waypoint. When ready, move the cursor to "ok?" and press ENTER.

```
2D Windows 25-NOV-92
<PA  aPT>          ok?
```

SkyNav computes a window of availability once the position, mode, and date have been selected and approved. This screen is displayed while the unit is computing the window.

```
2D AMTRA    25-NOV-92
computing windows..
```

When calculations are complete, the next screen displays the window of availability for the position, date, and GPS mode entered.

```

2D AMTRA    25-NOV-92
wndw  : 00:00-24:00Z
  
```

If less than 24-hour coverage is calculated, there may be more than one window of availability. The presence of additional windows is indicated by a "1" next to the colon. To view the rest of the windows, move the cursor to the "1" and turn the outer knob to scroll through the rest of the windows.

```

2D AMTRA    25-NOV-92
wndw 1: 08:00-1200Z
  
```

To continue to the next sats? page, press EDIT to turn the cursor off. Turn the outer knob to move to the next function.

Auto-Locate. The auto-locate function is a random search for satellites from all channels. It is conducted when an initialization error occurs and when the unit has no almanac or last position.

The random search follows a procedure that is designed to locate any satellite. Once a satellite is found, the unit collects an almanac from it. At the same time, the other channels continue to search for satellites. When enough satellites have been located to obtain a position fix, one is calculated. If the unit has no initial position, this fix is used as the initial position.

To initiate auto-locate, activate the cursor and move it to "go?", then press ENTER.

```

Auto-Locate
                go?
  
```

The screen displays the receiver performance screen while it searches for satellites and collects an almanac. As soon as enough satellites have been acquired to obtain a position fix, one is calculated and displayed. This usually happens before a complete almanac has been collected.

It should be noted that, since the unit calculates its first position fix with whatever satellites it can find, this position fix may not have the best possible accuracy. Once the unit has completed almanac collect and can determine if a better satellite set is available, SkyNav will switch to that set. Subsequent fixes should be the most accurate possible for the current location, time, day, and mask angle.

You can determine when almanac collect is finished by looking at the receiver activity screen. When "taking fixes" is displayed, almanac collect has been completed.



WARNING

The unit must remain on until almanac collect is finished. If the unit is turned off before almanac collect is finished it will have incomplete satellite information. This will adversely affect SkyNav's subsequent operation and accuracy until a complete almanac can be collected.

It is not necessary to wait for almanac collect to end before performing other functions with the unit. The receiver is active regardless of the function being performed; you may begin navigation, edit a flight plan, and even change units? settings during almanac collect.

units? FUNCTION

Many of the SkyNav's display parameters are set in the units? function. This option is selected when "units?" is selected from the AUX Main Menu Page.

CDI Scale. The CDI is the graphical representation of the cross-track error (if any) present when navigating between waypoints. SkyNav allows you to change the scale of the representation.

```

CDI Scale: 00.2"/dot
..+...▲.....
  
```

Each dot along the bottom of the screen is a marker that represents a distance unit. The sensitivity of the CDI scale is adjusted by changing the value of the distance unit in 0.1 increments. The default setting is 1.00 per marker.

Unit of Measure. This screen allows the user to establish what unit of measure will be used to display distance and speed. Changing the unit of measure here will affect all displays of distance and speed.

Three units of measure are available.

nm, kts = nautical miles, knots (factory default)
 mi, mph = statute miles, miles per hour
 km, kph = kilometers, kilometers per hour

```

Units: dist & speed
      nm,kts
  
```

To change the unit of measure, activate the cursor and scroll through the options. Press ENTER when the desired option is displayed.

Altitude Units. This screen allows the user to establish what unit of measure will be used to display altitude. Changing the unit of measure here will affect all altitude displays.

```

Units: altitude
      feet
  
```

You may select feet (default) or meters.

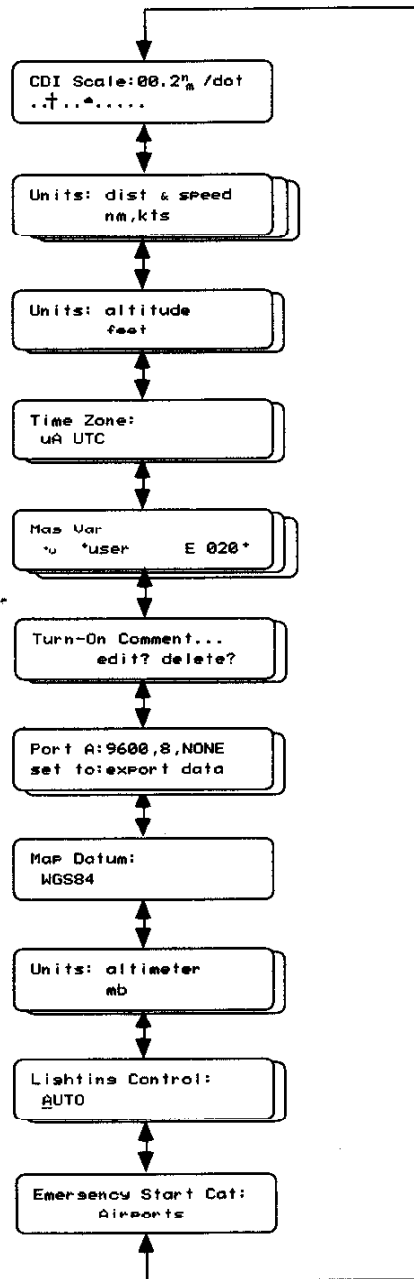

Figure 8-3. Flow Diagram of units? Screens

Time Zone. GPS operates on UTC; SkyNav therefore uses UTC to collect data and to calculate and store positioning information. SkyNav can, however, convert time to a local time zone for display. Changing the time zone here will affect all displays of time.

```

Time Zone:
Z UTC
  
```

When time is displayed in UTC, it is indicated by "Z". The exception is the time zone screen, shown below.

```

Time Zone:
Local (Z-03.0)
  
```

If you prefer to use local time, you will need to enter an offset to UTC. The offset is the difference between UTC and local time, including a "+" or "-" to indicate if local time is ahead of or behind UTC. For example, when UTC is 13:00 and local time is 8:00 a.m., the offset is -5:00.

When local time is displayed, no symbol is shown.

Magnetic Variation. This screen provides a way to change the magnetic variation, which affects displayed horizontal angle information. The SkyNav can display magnetic variation in three ways: an automatically derived magnetic variation, a user-defined magnetic variation, and none (true angles).

```

Mag Var:
*u *user E 020*
  
```

Magnetic variation type is selected by activating the cursor and scrolling through the options listed above. If you select user-defined, you may enter a magnetic variation from "E 180" to "W 180" in one-degree increments.

The magnetic variation type selected is indicated on position displays as:

- degrees magnetic
- *_T degrees true
- *_U degrees user-defined

Turn-On Comment. The comment is a user-entered reminder that appears on the screen during the power-up sequence. Its use is optional; if no text is entered, a blank comment page will be displayed.

```
Turn-On Comment...
      edit?  delete?
```

Select the "delete?" option to erase the existing turn-on comment. Select the "edit?" option to alter an existing comment or to enter a new one. The cursor is active when "edit?" is selected. The available entry area is 20 characters on the first line and 16 characters on the second line (up to "ok?").

```
CHECK OIL
                        ok?
```

Select "ok?" to save the turn-on message and return to the first turn-on comment screen.

Data Port Configuration. SkyNav has two RS-232C interface ports. The baud rate can be changed for each port. Each port may also have different settings and can be set independently to export data, to import data, or to "off." In addition, the parity bit of port A can be set to NONE, EVEN, or ODD; the parity bit of port B must be set to NONE.

```
Port A:9600,8,none
set to: export data
```

You may select:

data port	A or B
baud rate	1200, 2400, 4800, or 9600
parity bit	NONE, ODD, or EVEN (A only)
set to	export data, import data, or OFF

NOTE

If using an encoder, dataport A or B must be set to **receive** data.

Map Datum. This screen allows the user to select the map datum in which all position information will be displayed. (Map datums are described in *Appendix 2*.) The SkyNav has 47 pre-defined datums and one user-defined datum.

The unit's datum should always agree with the datum on which your maps and charts are based. (If the unit and map are using different datums, the positioning information displayed by the unit may differ from the map by as much as 600 meters.) The datum used is usually indicated in the map legend. Sometimes two datums are listed; use the horizontal map datum.

The unit contains an alphabetical list of preset datums (they are also listed in *Appendix 3*). The currently selected datum is displayed first. Activate the cursor and turn the inner knob to scroll through the list, starting with the current datum. Press ENTER when the desired datum is displayed.

MAP Datum:

WGS84

Changing the current datum changes all stored waypoints to the new datum.

SkyNav has a user-defined datum, which allows you to enter and use a local datum that is not pre-defined. To enter a user-defined datum, scroll the display to "USER" and select "edit".

Map Datum:	
USER	edit?

The parameters entered on the next five screens describe the local datum in relation to WGS84. (GPS is based on the WGS84 datum; SkyNav therefore calculates and stores positions in WGS84. If a datum other than WGS84 is selected, positioning information is converted from WGS84 to the selected datum for display.) Values for the user-defined datum parameters can be found in *Appendix 4*.

USER to WGS84
$\Delta a = +00000.00m$

USER to WGS84
$\Delta f \times 10^4 = +00.00000000m$

USER to WGS84
$\Delta x = +0000.0m$

USER to WGS84
$\Delta y = +0000.0m$

USER to WGS84
$\Delta z = +0000.0m$

NOTE

Be sure to indicate + or - for the values being entered.

Altimeter Settings. The altimeter units are used to specify an altitude encoder reference altitude.

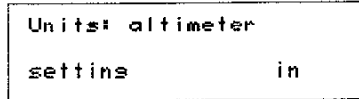

Units: altimeter
settings in

Select "mb" (millibars) or "in" (inches).

Lighting Level. Lighting level refers to the brightness of the display, the keypad, and the annunciator LEDs.

The lighting level can be adjusted to suit the current operating conditions. This can be done automatically by allowing the unit to change the lighting level, or manually by allowing the operator to select the brightness that is most comfortable.

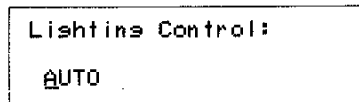

Lighting Control:
AUTO

When "auto" is selected, SkyNav automatically selects a setting from 2 to 16 as necessary to dim or brighten the display, keypad, and LEDs in relation to the ambient light in the cockpit.

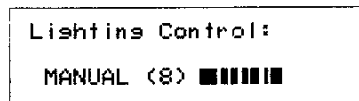

Lighting Control:
MANUAL (8) ■■■■■■

If "manual" is selected, the intensity of the light is manually adjustable. Move the cursor to the number in parentheses. The number represents light intensity, which can be set from 1 (low) to 16 (high). The bar on the right provides a graphic indication of the current light intensity. The bar will shorten and lengthen as light intensity is changed.

The lowest setting (1) turns off all keyboard lighting to enhance night vision. Setting 2 and setting 1 have the same intensity, but setting 2 has keyboard lighting.

Emergency Start. Emergency start allows you to choose the waypoint category that is searched first when EMG is pressed. (The default is airports.)

This feature is accessed from the lighting control display or directly from the main AUX menu. From the main AUX menu, move the cursor to units? and press ENTER, then turn the outer knob on notch counterclockwise.

To select which category will be searched first, press EDIT, then turn the inner knob to select another category. Press ENTER to save the change made.

↓timer FUNCTION

The timer is a countdown counter. It is used to count down from a user-entered length of time (up to 99 minutes, 59 seconds) to 0 seconds. The timer can be edited, started, interrupted, and the output can also be redirected to the first NAV display, where it replaces the groundspeed display.

```
↓timer:   < 03:00 >
start? stop? load?
```

When this screen is accessed, the time displayed is either the last value entered or the time displayed when the countdown timer was interrupted.

To enter a value, activate the cursor and move it to the time field. Enter a value, and press ENTER. If zero minutes is entered, SkyNav will ignore the new entry and use the previous value.

The timer can be started by selecting either start? or load? and pressing ENTER. Select "start?" to start the countdown timer in the current display. Select "load?" to direct timer output to the first NAV display and to start counting down.

The countdown timer can be interrupted at any time before 00:00 by selecting the stop? option. This will also return the groundspeed display to the first NAV screen.

stopwatch? FUNCTION

The stopwatch is accessed and controlled from the AUX Main Menu screen. The time field on the first line **cannot** be edited, and always starts with 00:00 (zero minutes, zero seconds). When the stopwatch reaches 59:59 (59 minutes, 59 seconds), seconds are no longer displayed; time is displayed as hours and minutes (separated by an "h"), starting with 01h00.

The stopwatch can be started with either "start?" or "load?". Select "start?" to start the stopwatch in the current display. Select "load?" to direct stopwatch output to the first NAV display (where it replaces the groundspeed display) and to start the timer.

The "stop?" option halts timing; if timer output was directed to the first NAV screen, "stop?" also removes the timer output from the NAV screen. The unit continues to display the last value calculated by the timer; the value returns to 00:00 when the stopwatch function is de-activated.

NOTE

If both the timer and the stopwatch countdown are loaded, the stopwatch output overrides the countdown timer display. To return to the original NAV display, both timers must be unloaded.



Chapter 9

THE EMERGENCY MODE

The Emergency mode provides immediate access to the emergency waypoint list. The emergency list contains the five waypoints from each database category that are closest to the present position; therefore, the list contains up to 20 waypoints when SkyNav has only the standard internal database, and up to 30 waypoints when the expanded database has been installed.

The emergency list, is constantly updated when EMG is pressed, and can be accessed only from the Emergency Mode.

Waypoints are displayed by category; within each category, waypoints are listed in the order of their proximity to your position.

The categories are displayed in the order shown in Figure 9-1 unless you have selected another starting category in the units? submenu of the AUX function.

Use the inner knob to scroll through the list; the last waypoint in one category is followed by the first waypoint in the next category. The outer knob scrolls through the pages of the currently displayed waypoint record.

NOTE

Waypoint records accessed with the EMG button cannot be edited.

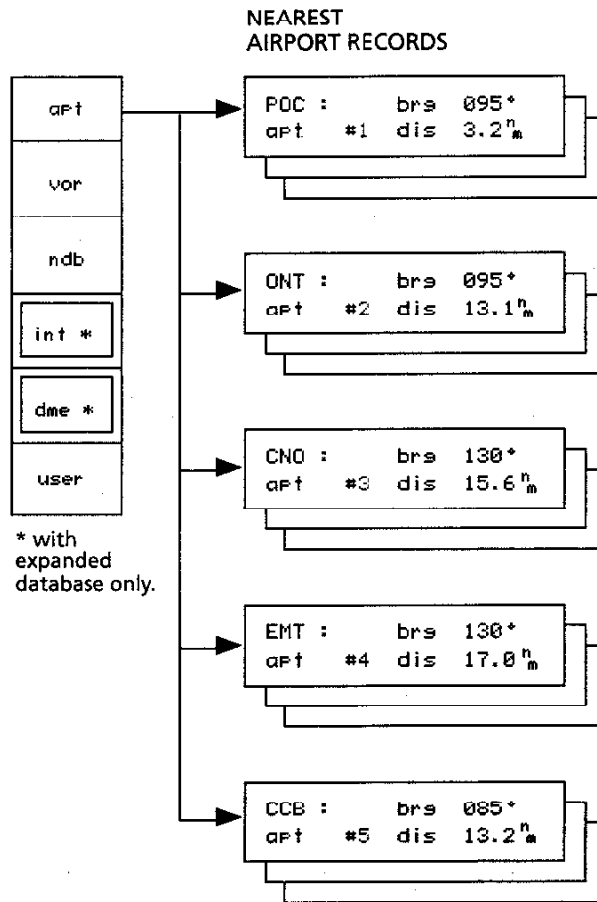

Figure 9-1. Sample Emergency Mode List

Direct-To is an overlay function that permits the pilot to quickly define a course from the present position to any waypoint. The course is essentially an active 1-leg flight plan; all navigation information is available.

Accessing Direct-To has two immediate effects on the SkyNav display:

- any cursor activity that is in progress when the **B→** button is pressed is cancelled, and
- the screen currently displayed is overlaid with the Direct-To display.

Pressing **B→** does not de-activate the current mode; the selected mode remains active under the Direct-To display, and is re-accessed by cancelling the Direct-To function as described below.

The starting waypoint of a Direct-To course is always the present position.

SkyNav automatically selects and displays a destination waypoint when **B→** is pressed, based on the contents of the previous display. If the previous page displayed:

a waypoint,	that waypoint is displayed;
more than one waypoint (e.g., a NAV screen)	the TO-waypoint is displayed;
no waypoint, but a flight plan is active,	the destination for the active leg is displayed;
no waypoint, and no flight plan is active,	the first item in the database is displayed. (If the database has been accessed during the cur- rent operating session, the last- viewed item is displayed.)

When the previous display implies a waypoint, that waypoint is used as the destination waypoint. The destination waypoint is always shown on the first line and inside of brackets. The waypoint can be changed by editing the waypoint name, as described in Chapter 7.

```
B→: <OSH >  
approve B→: yes? no?
```

The Direct-To function is not activated until it is approved (after the waypoint is chosen) by selecting the "yes?" option. If "no?" is selected, the Direct-To function is cancelled and the display for the active mode is restored.

Once approved, a course from the present position to the selected waypoint is established and becomes the desired track.

If there is an active flight plan when B→ is pressed and the Direct-To destination is not part of that flight plan, the flight plan is de-activated. If the Direct-To destination is part of the active flight plan, you are asked if the flight plan will terminate at the displayed waypoint.

```
Terminate at OSH :  
yes? no?
```

When "yes?" is selected, the course from the present position to the displayed waypoint becomes the desired track and the flight plan is de-activated. If "no?" is selected, the course from the present position to the displayed waypoint becomes the desired track and the flight plan remains active.

Once the Direct-To function is activated, the first NAV screen becomes the active display. A FROM-waypoint is not displayed; the Direct-To symbol (B→) is displayed at that location.

SkyNav is an easily operated navigating aid, but occasional questions may arise during normal operation. This chapter is intended to be a ready reference for the most frequently raised questions.

DETERMINING THE QUALITY OF A FIX

The quality of a position fix (and therefore, the navigation data output by SkyNav) is affected by satellite geometry and the strength of the signals being received from the satellites. If a weak signal is lost, the receiver may not be able to maintain the 1-second update rate. Either condition will cause the unit to regard the present position as invalid and generate a warning message.

Geometric Quality. The accuracy of a position fix is determined by the position of the satellites being used relative to each other. In general, the closer the satellites are to each other, the less accurate the fix tends to be. This is referred to as the geometric quality (GQ).

SkyNav assesses the geometric quality of the position fix and assigns it a numerical value between 0 and 9. A position fix with a GQ of 9 has the best possible geometry; a GQ of 4, while not as accurate, is still usable.

If the GQ of a fix is 3 or less, SkyNav generates a warning message (which is accessed with the MSG overlay function). At the same time, the annunciator light for the current GPS mode (either 2D or 3D) goes from green to red. (If an external GPS annunciator is being used, it will also indicate poor fix quality.) When the GQ rises to 4 or better, the warning message automatically clears and the GPS annunciator light turns to green.

Since SkyNav always selects the best possible satellites for a position fix (given the last known position) from the satellites that it can locate, there is usually little the user can do to improve a poor GQ. The geometry of a satellite set may be improved by a change in location; travelling a short distance may improve the geometry of the best available satellite set.

Verify the mask angle that was selected in the AUX mode. If the mask angle was set manually, it may be too high to take advantage of all of the satellites that are currently above the horizon.

Dated Information. If the signal being received from one or more satellites is especially weak, the receiver may be unable to maintain a lock on it. When a signal is lost, the unit attempts to re-locate and re-acquire the satellite. If this is successful within 10 seconds, there is very little interruption to the update rate.

Occasionally though, the receiver is unable to re-locate the satellite. After 10 seconds of being unable to re-locate the lost satellite(s), SkyNav attempts to substitute the satellite(s) that will produce the next-best GQ. Unless the new satellite has been found and acquired in the last 2 hours (and the unit still has ephemeris data for it), the search may take a few minutes. As soon as the new satellite is acquired, a new position fix is produced.

While the unit is searching for the lost satellite or for a replacement satellite, the unit is unable to produce new fixes. All navigation information is therefore based on the most recent position fix. At the same time, a warning message is generated that can be displayed with the MSG overlay function, and the current GPS mode's annunciator light goes to red.

INITIALIZATION ERROR

An initialization error occurs when:

- the date and time accepted during the turn-on sequence was the cold start default (2400 hrs, 06-JAN-80)
- the initial position entered or accepted during the turn-on sequence was the factory default (N____°____' W____°____')
- the initial position entered or accepted during the turn-on sequence was incorrect by 500 miles or more

The first condition will cause the unit to be unable to reconcile its almanac with the initial date and time. The second and third conditions will cause the receiver to be unable to find the satellites it looks for.

SkyNav searches for satellites based on where it thinks it is. An initial position that is 500 miles or more away from the receiver's present position may cause the receiver to search for satellites that are not available to the unit's true location.

While the receiver may be able to locate the satellites it is looking for, the position fix it calculates will be so far from its initial position that the unit regards the fix as an error. SkyNav tries three more times to obtain a position fix that is within 500 miles of the initial position.

After the fourth attempt to obtain an acceptable position fix, the unit discards the initial position and assumes that an initialization error has occurred. SkyNav then re-initializes itself, using the satellites that it has already acquired. This process takes between 10 and 60 seconds.

Sometimes the initial position is so far from the present position that the unit is unable to locate enough satellites to obtain a fix. When this happens, the unit initiates Auto-Locate. In Auto-

Locate, the receiver begins Sky Search to locate satellites and then enters Almanac Collect, which ensures that the unit is using the most current almanac information possible. At the same time, SkyNav calculates a 2D position fix as soon as three satellites have been located and acquired. This fix is used as the initial position. If SkyNav does not have a position fix after about 20 minutes, either re-initialize the unit as described in Chapter 2, or initiate Auto-Locate from the AUX mode.

NOTE

Initialization errors can be avoided by properly initializing the unit during the Turn-On Sequence. A correct or best-guess initial position or "near airport" must be used, especially if the unit has been moved a significant distance.

TURNING THE UNIT OFF

SkyNav is turned off by pressing the On/Off button. The unit does not switch off immediately, however. The display is overlaid with a message requesting verification of the action.

```
Switch off SkyNav...
                4 no?
```

The second line displays an active 5-second countdown timer and the "no?" option; the cursor is active on "no?". If no action is taken before the timer reaches 0 seconds, SkyNav will power down. If "no?" is approved, SkyNav will remain on.

SkyNav cannot be turned off during almanac collect or verify without a conscious decision on the part of the user to do so.

If the receiver is collecting or verifying an almanac when the PWR button is pressed, the overlay page includes receiver status information.



Collecting almanac !
switch off.. 5 no?

Verifying almanac !
switch off.. 5 no?

SkyNav will power down when the countdown timer reaches 0 seconds; this will interrupt almanac collect/verify, and may affect how quickly SkyNav can produce a position fix when it is turned on again. Select "no?" to leave the unit on.

SELECTING A GPS MODE

The SkyNav 5000 can calculate a latitude/longitude position fix or a latitude/longitude/altitude position fix. Which type of fix the unit calculates is determined by which GPS mode is selected in the AUX mode.

When the 2D GPS mode is selected, the unit uses three satellites to calculate a latitude/longitude position fix. Altitude is a fixed value that is entered and periodically updated by the user. (A reminder to update the altitude is generated by the unit every 10 minutes. It is accessed with the MSG overlay function.) If the unit has been connected to a compatible altitude encoder and has been set to accept encoder input, altitude can also be updated by the altitude encoder.

When the 3D GPS mode is selected, the unit uses four satellites to calculate a latitude/longitude/altitude position fix. Altitude is part of the position solution, and cannot be input manually or from an external source.

An automatic GPS mode can also be selected. AUTO uses 3D operation as long as four satellites are available. If there are not enough satellites for a 3D position fix, the unit automatically switches to 2D operation. When enough satellites become

available for 3D operation, the unit switches back. Any time switching occurs, the unit generates an appropriate message, which is viewed by accessing the MSG overlay function.

SkyNav always uses the GPS mode you select, with two exceptions. Since SkyNav is designed to provide a position fix as quickly as possible, and it is usually faster to locate three satellites than four, a 2D fix is provided during Almanac Collect and Auto-Locate. Subsequent fixes will be provided in the GPS mode selected.

EXTERNAL ANNUNCIATORS (OPTIONAL)

Three external annunciators can be installed in the pilot's line of sight to alert the pilot to changes in navigation information: a NAV annunciator, a GPS annunciator, and a WPT annunciator.

The external NAV annunciator is active (on) when SkyNav is providing valid NAV data to a moving map or autopilot.

The external GPS annunciator is active (on) when GQ is less than 3. A low GQ occurs when current satellite geometry could yield position errors greater than .15 NM.

The external WPT (waypoint) annunciator is active (on) when the calculated time to the next waypoint is less than 1 minute. This alerts the pilot of an imminent turn or bank.

USING SKYNAV NEAR THE POLES

Since all lines of longitude converge at the North and South poles, a unit of measure can span many degrees of longitude near the poles. This means that small changes in position can cause large variations in the information displayed by the unit.

The inherent accuracy of SkyNav does not change near the poles, but this mathematical sensitivity can cause position and velocity-related data to appear unstable when the unit is operated at latitudes greater than 85 degrees north or south of the equator. Use caution in interpreting displayed data in these areas.

TROUBLESHOOTING

This section describes some of the most frequently asked questions relating to operating conditions

POSITION FIX DOESN'T CHANGE

The signal from one or more satellites has been lost; the position fix displayed is the most recent one available.

Check the messages with the MSG button and follow any instructions displayed.

FIXES VARY A LOT

The position accuracy of SkyNav is affected by several variables, the most important of which is the GQ (geometric quality). Therefore, the specified accuracy of 15 meters RMS in 2D is statistical, not absolute. Also, it is assumed that GQ is greater than 7 and SQ is at least 7. Even under good conditions, then, not all fixes will be within 15 meters of the true position.

A good rule of thumb is that approximately two-thirds of the fixes will be within 15 meters of the true position and about 95% of the fixes will be within 25 meters under good operating conditions. This assumes that the system's accuracy is not being degraded. (Degradation can be as much as 100 meters.)

Since 20 meters is approximately 0.01 minute of latitude (and 0.01 minute of longitude at the equator), it is normal to see variations of ± 0.03 minutes of latitude/longitude from fix



to fix when conditions are good. Under less favorable conditions, larger variations are normal.

If the unit is being operated near the poles, small changes in position may cause great variations in position and velocity-related data. Refer to *Using SkyNav Near the Poles*.

EXTERNAL DEVICES NOT RESPONDING

Output messages aren't in the correct format. Refer to the device's user guide to determine the correct message format. Check units? in the AUX mode to verify SkyNav's settings, and make any necessary changes.

Receiver is not taking fixes. Check the messages; the unit may be displaying old data. Also, check the mask angle; if a manual mask angle was selected in units? (AUX mode) it may be too high.

AUTOPILOT DOES NOT RESPOND

Refer to *External Devices*, above.

Autopilots use cross-track error information, which the unit does not calculate unless a flight plan is active.

Enter and/or activate a flight plan or Direct-To.

NAV DOESN'T WORK

You must be travelling faster than one speed unit (whichever was selected in the AUX mode) to get velocity-related data such as ground-speed, steering, and estimated time of arrival.





ZEROS APPEAR IN NAV DISPLAYS

Increase speed.

Navigation- and velocity-related data is not available until three fixes have been made.

Wait until three position fixes have been taken (usually about 2 seconds after the first fix), and try again.

Your speed is too slow to provide velocity-related data such as speed and steering. You must be travelling at least one speed unit (whichever was selected in the AUX mode) to obtain this data.

Increase your speed to at least one unit.

SOME VALUES IN NAV DISPLAY NOT STABLE

Certain values are calculated from an instantaneous measurement of speed. Since speed may fluctuate from one instant to another, these calculations may appear to be unsteady. The navigation calculations that may be affected are ground speed, estimated time of arrival, and estimated time en route.

This is normal. Fluctuations are usually small. If necessary, read a mean of the values displayed for a calculation to determine a stable value.

SATELLITE AVAILABILITY NOT TO YOUR EXPECTATIONS

The position or health of a satellite may have been changed by the U.S. Government. You may also have last collected an almanac on a day when one or more satellites were set to "unhealthy."

If necessary, you can also return your unit to Magellan for repair. (Please call Customer Support for assistance first.) If possible, please notify us before shipping the unit by Parcel Post or UPS, and include with the unit a description of the problem and your name, address, and telephone number. If your return shipping address is different, please include it.

Packages should be sent to:

Magellan Systems Corporation
960 Overland Court
San Dimas, CA 91773
Attention: Warranty Repair

GLOSSARY

This user guide includes a number of terms that may be unfamiliar to you. This section is intended to give a brief description of unfamiliar terms that you may have noticed in the preceding chapters.

- acquisition** Occurs when the unit locates a satellite and collects data from it.
- almanac** General positioning and scheduling information for the satellite constellation that is broadcast by all satellites. Also information that is maintained by the GPS receiver.
- C/N₀** Carrier signal-to-noise ratio. An absolute means of specifying the signal-to-noise ratio (SNR) that is independent of bandwidth. Indicated by SkyNav as SQ.
- ephemeris** Precise positioning information that is broadcast by each satellite. Includes date and time.

geometric quality An estimate of the accuracy of the position fix, based on the location of the satellites being used in the position solution relative to each other. Usually abbreviated as GQ. GQ is ranked from 0 to 9, with higher numbers indicating greater accuracy. A GQ of 3 or below is poor, and caution should be exercised in using fixes with such low ratings.

GQ See geometric quality.

map datum A method of assigning position coordinates to real-world locations. Based on an underlying ellipsoidal model of the earth, and subject to other scientific assumptions. Identified by a unique name, such as WGS84 or NAD27.

mask angle The angle below which the receiver will not search for satellites.

ppos present position. Appears on the display in Satellite Window utility of the sats? subfunction of the AUX function and when entering a user-defined waypoint.

receiver The electronic components of SkyNav that receive and process satellite signals.

Selective Availability A technique used by the government to introduce errors into positioning information broadcast by the GPS constellation. Abbreviated as SA. Typical degradation is around 100 meters. Effects can be removed from data with differential GPS.



**signal
quality**

An indication of the strength of the signal being received from a satellite. Usually abbreviated as SQ. SQ is ranked from 0 to 9, with 9 being the strongest. An SQ of 3 or less indicates that one or more of the signals being received is weak, and the receiver may be unable to maintain a lock on it. SQ does not affect the accuracy of the position fix; it is an indication of the strength of the signals being received.

SQ

See signal quality.

UTC

Universal Coordinated Time; time referenced to the prime meridian; formerly referred to as Greenwich Mean Time.

