

MC

# COMBOMAX

*Electric boiler with integrated instantaneous water heater*

Models from 8 kW to 24 kW :  
240 Volts ( single phase )

## Use and Care Manual

With installation instructions for the contractor



Your *COMBOMAX*<sup>®</sup> electric boiler has been carefully assembled and factory tested to provide years of trouble-free service. This manual contains instructions for the safe and proper installation, operation and maintenance of the boiler, in order to ensure your full satisfaction

It is imperative that all persons who are expected to install, operate or adjust this boiler read the instructions carefully.

Any questions regarding the operation, maintenance, service or warranty of this water heater should be directed to the dealer or distributor you purchased it from. When all installation steps have been completed, replace this installation manual in its original envelope, and keep in a safe place near the heater for future reference.

## Section 1 : Technical specifications

**Table 1: Boiler specifications 240 Vac (single phase) :**

Model	Power		Nominal load in amps		Number of elements	Stages \ Thermostats \ pilots	Wire Cu	Fuse Amps
	Kw	BTU/h	Heating elements	Including the circulator				
COMBOMAX XX-8	8	27 296	33.3	34.3	1 X 3KW 1 X 5KW	2	8	50
COMBOMAX XX-10	10	34 120	41.6	42.6	2 X 5KW	2	6	60
COMBOMAX XX-15	15	51 180	62.5	63.5	2 X 3KW 2 X 4.5KW	4	3	100
COMBOMAX XX-18	18	61 416	75.0	76.0	4 X 4.5KW	4	3	100
COMBOMAX XX-20	20	68 240	83.4	84.4	4 X 5KW	4	2	125
COMBOMAX XX-24	24	81 888	100.0	101.0	4 X 6KW	4	1	125

**Table 2 : Boiler and connection dimensions**

Model	Capacity	Utility connection	Boiler connection	Height	Diam.	Ship. weight
Combomax 23	30 Gal US	3/4 " Sweat F	1" NPT F	49"	18"	265 lbs
Combomax 34	40 Gal US	3/4 " Sweat F	1" NPT F	65"	18"	315 lbs
Combomax 44	52 Gal US	3/4 " Sweat F	1" NPT F	55"	22"	345 lbs
Combomax 64	76 Gal US	3/4 " Sweat F	1" NPT F	67"	24"	425 lbs

**Table 3 : Domestic hot water production capacity in US gallons**

Model	1st hour			Continuous		
	110F	140F	180F	110F	140F	180F
COMBOMAX 23-8	75	44	28	47	33	24
COMBOMAX 23-10	87	52	33	59	41	29
COMBOMAX 23-15	116	73	48	88	62	44
COMBOMAX 23-18	134	85	57	106	74	53
COMBOMAX 23-20	145	93	63	117	82	59
COMBOMAX 23-24	169	110	75	141	99	71

Model	1st hour			Continuous		
	110F	140F	180F	110F	140F	180F
COMBOMAX 34-8	85	48	29	47	33	24
COMBOMAX 34-10	97	56	34	59	41	29
COMBOMAX 34-15	126	77	49	88	62	44
COMBOMAX 34-18	144	89	58	106	74	53
COMBOMAX 34-20	155	97	64	117	82	59
COMBOMAX 34-24	179	114	76	141	99	71

Model	1st hour			Continuous		
	110F	140F	180F	110F	140F	180F
COMBOMAX 44-8	97	53	31	47	33	24
COMBOMAX 44-10	109	61	36	59	41	29
COMBOMAX 44-15	138	82	51	88	62	44
COMBOMAX 44-18	156	94	60	106	74	53
COMBOMAX 44-20	167	102	66	117	82	59
COMBOMAX 44-24	191	119	78	141	99	71

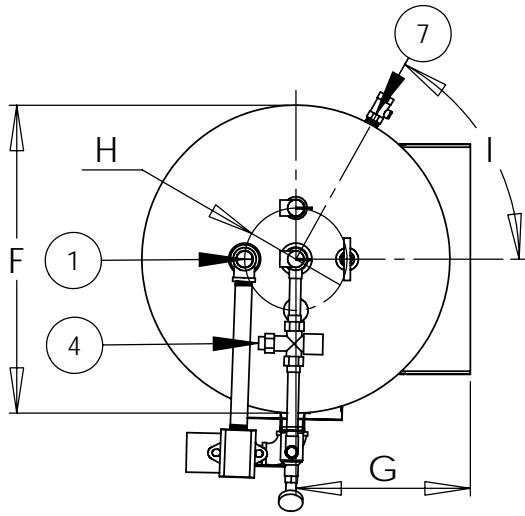
Model	1st hour			Continuous		
	110F	140F	180F	110F	140F	180F
COMBOMAX 64-8	121	63	34	47	33	24
COMBOMAX 64-10	133	71	39	59	41	29
COMBOMAX 64-15	162	92	54	88	62	44
COMBOMAX 64-18	180	104	63	106	74	53
COMBOMAX 64-20	191	112	69	117	82	59
COMBOMAX 64-24	215	129	81	141	99	71

With domestic cold water at 40°F and heating water at 180°F

**Operating temperature : from 50°F to 190°F; Maximum operating pressure: 30 psi**

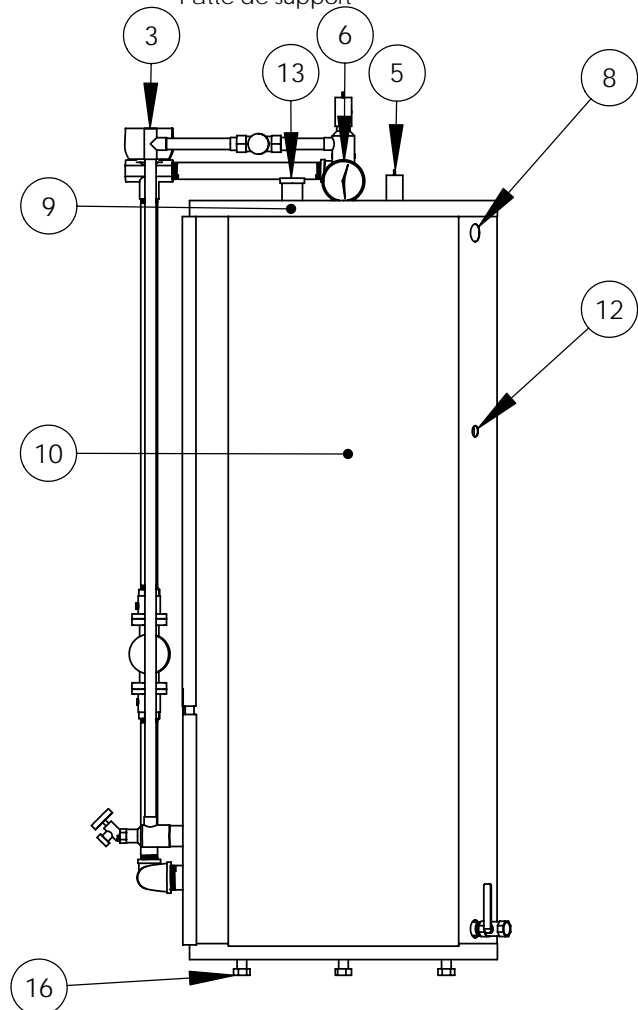
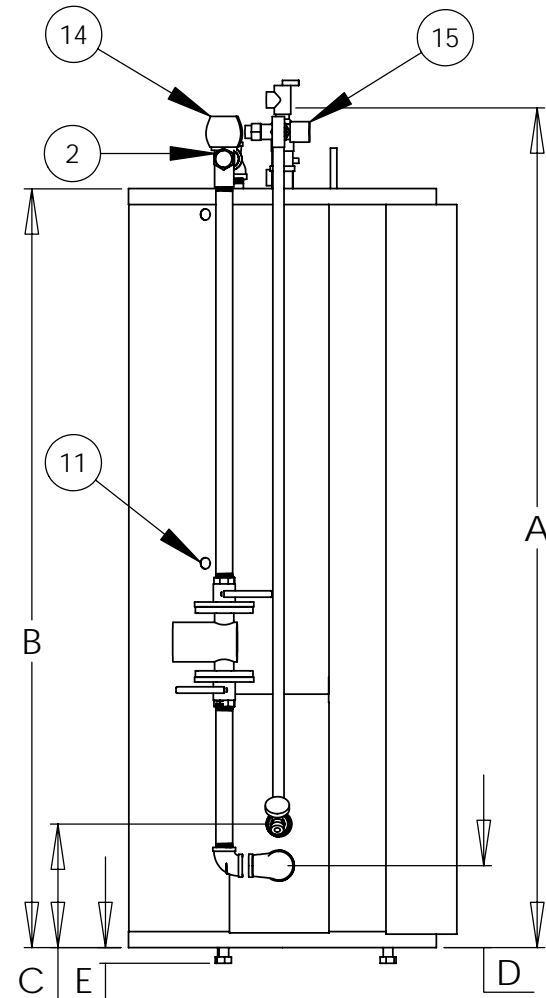


Figure 2



Legend/Légende:

- 1) Boiler Water Supply Connection / Alimentation du chauffage (1" npt F)
- 2) Boiler Water Return/ Retour du chauffage (1" npt F)
- 3) Domestic Water inlet / Entrée eau domestique (3/4" Sweat F)
- 4) Domestic Water outlet/ Sortie eau domestique (3/4" Sweat F)
- 5) Safety relief valve/ Soupape de sûreté (3/4" npt M.)
- 6) Temperature and pressure Gage/ Indicateur de température et pression (1/2" npt. M)
- 7) Drain Valve/ Valve de drainage (3/4" npt F)
- 8) Power supply wiring/ Alimentation électrique
- 9) Pilot Lights/ Lampe témoin
- 10) Electrical Compartments/ Compartiment électrique
- 11) Circulator wiring/ Alimentation pompe
- 12) Thermostat wiring/ Connection thermostat
- 13) Air vent/ Purgeur d'air
- 14) Valve 3 voies/ 3 ways valve
- 15) Valve thermostatique/ Thermostatic mixing valve
- 16) Adjustable leg/ Patte de support



**DIMENSION/ DIMENSIONAL**

Modèle/ Model	A in.	B in.	C in.	D in.	E in.	F in.	G in.	H in.	I degrés/degree
COMBOMAX 23-XX	49 3/16	42 1/4	7 1/4	4	1	18	10 1/2	8	75
COMBOMAX 34-XX	65 1/2	59	7 1/4	4	1	18	10 1/2	8	75
COMBOMAX 44-XX	57 3/4	49 1/2	9 1/2	5 3/4	1	22	12 1/2	8	60
COMBOMAX 64-XX	65 1/2	58 1/2	9 1/2	6 1/2	1	24	13 1/2	8	60



## General Safety Precautions

Be sure to read and understand the entire Use & Care Manual before attempting to install or operate this water heater. Pay particular attention to the following General Safety Precautions. Failure to follow these warnings could cause property damage, bodily injury or death. Should you have any problems understanding the instructions in this manual, STOP, and get help from a qualified installer or technician.

---

## Section 2 : Introduction



### WARNING

**The important safeguards and instructions appearing in this manual are not meant to cover all possible conditions and situations that may occur. It should be understood that common sense, caution and care are factors which cannot be built into every product. These factors must be supplied by the person(s) caring for and operating the unit.**

### 2.1 LOCAL INSTALLATION REGULATIONS

This water heater must be installed in accordance with these instructions and must conform to local, or in the absence of local codes, with the current edition of the National Plumbing Code and the National Electric Code. In any case where instructions in this manual differ from local or national codes, the local or national codes take precedence.

### 2.2 CORROSIVE ATMOSPHERE

The heater should not be located near an air supply containing halogenated hydrocarbons or high humidity. The limited warranty is voided when failure of the water heater is due to a corrosive atmosphere.

### 2.3 SHIPMENT INSPECTION

Inspect the water heater for possible shipping damage. The manufacturer's responsibility ceases upon delivery of goods to the carrier in good condition. Consignee must file any claims for damage, shortage in shipments, or non-delivery immediately against carrier.

### 2.4 CHECKLIST

Please check the technical information plate to ensure you have the right model.

The following items are shipped with the unit :

- 30 PSI pressure relief valve.
- Drain cock.
- Thermo manometer (heat and pressure indicator).
- Thermostatic mixing valve



### WARNING

**The boiler should not be located in an area where leakage from the tank or water connections will result in damage to the adjacent area or to lower floors of the structure. When such areas cannot be avoided, a suitable drain pan or non-flammable catch pan, adequately drained, must be installed under the boiler. The pan must be connected to a drain.**

**NOTE: Auxiliary catch pan MUST conform to local codes.**

## Section 3 : INSTALLATION



### WARNING

The manufacturer's warranty does not cover any damage or defect caused by installation or attachment or use of any special attachment other than those authorized by the manufacturer into, onto, or in conjunction with the water heater. The use of such unauthorized devices may shorten the life of the water heater and may endanger life and property. The manufacturer disclaims any responsibility for such loss or injury resulting from the use of such unauthorized devices.

### 3.1 SAFETY MEASURES

All domestic and commercial installations will include a pressure relief valve limiting the operating pressure to 30 psi.

This *COMBOMAX<sup>MC</sup>* electric boiler is designed for a maximum operating temperature of 190°F. It is designed as a hot water heating system only. A 30 to 50% water and ethylene- or propylene-glycol blend is allowed.

### 3.2 LOCATION

The *COMBOMAX<sup>MC</sup>* water heater should be installed in a clean, dry location. Long hot water lines should be insulated to conserve water and energy. The water heater and water lines should be protected from exposure to freezing.

*COMBOMAX<sup>MC</sup>* water heaters must be installed vertically. Use the adjustable feet to level the unit.

The *COMBOMAX<sup>MC</sup>* water heater must be located or protected so as not to be subject to physical damage, for example, by moving vehicles, area flooding, etc..

All models can be installed on combustible floors and in alcoves. If the water heater is to be installed in a restaurant or other location where the floor is frequently cleaned, it must be elevated to provide at least 6 inches of clearance from the floor to comply with NSF International recommendations.

The room temperature must not exceed 80°F or 27°C.

### 3.3 CLEARANCE

The minimum clearances required for proper inspection and servicing are as follows:

Table 4: Clearances

Left side	3 inches
Right side	3 inches
Top	24 inches
Front	24 inches
Back	3 inches

### 3.4 SYSTEM SETUP

Figures 2, 3 and 4 are general connection diagrams including the circulator, the expansion tank, the drain cock, the safety valve, the air bleeder, the flow check valve and the thermo manometer. Set-up details follow.

### 3.5 HEATING WATER CIRCUIT

#### 3.5.1 Connecting the heating water piping

The boiler may be set up alone or in parallel with others. Parallel connections should be made using the reverse-piping method to ensure equal flow through each boiler.

The boiler water supply connector is located on top of the boiler and the boiler water return connector is located to the left of the three-way valve. They are both threaded NPT female connectors.

Unions are recommended on the hot and cold water lines to disconnect the water heater easily for servicing if necessary.

Dielectric (insulating) unions are required for protection of the water heater if copper-steel connections are made.

Use only clean copper or approved plastic pipe for water connections. Local codes or regulations shall govern the exact type of material to be used.

Insulate all pipes containing hot water, especially in unheated areas.

Install shutoff (ball) valves for servicing convenience. Install thermometers on the inlet and outlet lines.

**Never plug the pressure relief valve** to avoid creating a hazardous situation.

### 3.5.2 Flow-check valve

If the heating system uses a single circulator, a **flow-check valve must be installed** to minimize gravity flow and heat loss during non-draw periods.

### 3.5.3 Pressure relief valve

No boiler set-up is complete without a pressure relief valve. Its pressure rating must not exceed 30 psi (207 kPa). It must conform to the « *ASME Boiler and Pressure Vessel Code* » and limit the boiler operating pressure. It is a safety device, not a control device.

The BTU per hour rating of the relief valve must equal or exceed the BTU per hour input of the boiler(s) or heat source(s) as marked on the boiler(s) rating plate.

Connect the outlet of the relief valve to a suitable open drain, with the discharge at most 6" above the floor, far from any live electrical parts. The discharge line must pitch downward from the valve to allow complete draining and be no smaller than the outlet of the valve. The end of the discharge line should not be threaded or concealed and should be protected from freezing. No valve of any type, restriction or reducer coupling should be installed in the discharge line. Local codes shall govern the installation of relief valves.

### 3.5.4 Operating pressure control : expansion tank

Operating pressure control components ensure minimum and maximum operating limits are observed within the design operating temperature range. These components allow bleeding air from the piping, prevent boiling and cavitation at the circulator inlet, while minimizing the amount of fresh water input. Please contact a qualified plumber or contractor for more information on this subject.

The expansion tank connection point must be carefully chosen to prevent a situation where closing a valve would isolate the tank from the

boiler or any part of the circuit. It is preferable to use a calibrated diaphragm expansion tank.

### 3.5.5 Makeup valve

Connecting a makeup valve must be done according to code. This valve must include a flow-check valve to maintain the minimum operating pressure by admitting fresh water from the cold water supply line in case a leak occurs.

### 3.5.6 Air bleeder

There should be as little oxygen as possible in the heating circuit to prevent corrosion. As foreseen in section 3.5.4, this excludes the use of air as a pressure regulator within the circuit.

Installing manual or automatic air bleeders prevents air accumulation within the system. The bleeders must be set at the highest points of the system to purge any air accumulated during system set-up and to check its air tightness. Bleed the air regularly from the piping, making sure the heating water causes no bodily harm or material damage.

### 3.5.7 Circulator zoning

A flow-check valve must be installed in each zone, preferably at the outlet of each circulator, to prevent water flowing to zones where no heat is currently required. (see figure 4).

### 3.5.8 Zone valve zoning

Zone valves with low pressure drop are recommended. (see figure 3)

### 3.5.9 Circulator selection criteria

The *COMBOMAX<sup>MC</sup>* boiler includes a pre-mounted circulator. The information below will help you select additional units for multiple circulator set-ups.

#### 3.5.9.1 Pump flow rate calculation

The boiler output rating must correspond to the calculated heating load. Use the equation below to calculate the pump flow rate:

$$\text{Pump flow rate} = \text{Boiler output} \div \text{BWTD} \div 500$$

- Pump flow rate is expressed in U.S. gallons per minute or GPM.
- The Boiler output ( in net BTU per hour) is the maximum amount of heat to be transferred through the heating circuit to meet the hot water demand.
- BWTD is the boiler water temperature drop through the heating circuit.

For example, a 24 Kw *COMBOMAX<sup>MC</sup>* boiler has a rated output of 81,964 BTU/hour. The system is designed for a boiler water temperature drop (BWTD) of 20°F.

$$\text{Pump flow rate} = 81,964 \div 20 \div 500 = 8,2 \text{ GPM.}$$

The following table shows the required flow rate as a function of boiler water temperature drop (BWTD) and rated power output.

**Table 5 : BWTD vs. flow (GPM)**

Model	Kw	BWTD			
		10° F	20° F	30° F	40° F
COMBOMAX XX-8	8	5,5	2,7	1,8	1,4
COMBOMAX XX-10	10	6,8	3,4	2,3	1,7
COMBOMAX XX-15	15	10,2	5,1	3,4	2,6
COMBOMAX XX-18	18	12,3	6,1	4,1	3,1
COMBOMAX XX-20	20	13,7	6,8	4,6	3,4
COMBOMAX XX-24	24	16,4	8,2	5,5	4,1

### 3.5.9.2 Selecting a circulator

Consult the manufacturer's operating characteristic curves to select the proper model. These curves plot flow versus pressure, together with other information such as efficiency and power. Ask your pump dealer or HVAC wholesaler to recommend the circulator which best fits your needs.

## 3.6 DOMESTIC HOT WATER CIRCUIT

### 3.6.1 Connecting the domestic hot water piping

The *COMBOMAX<sup>MC</sup>* domestic hot water coil may be set up alone or in parallel combination with other *COMBOMAX<sup>MC</sup>* units or storage tanks. Parallel connections should be made using the

reverse-piping method to ensure equal flow through each boiler.

The HOT WATER OUTLET and the COLD WATER INLET connections are clearly marked. Inlet water connections (COLD WATER INLET) are to be made to the copper pipe (sweat connection) at the bottom of the heater. Outlet water connections (HOT WATER OUTLET) are to be made to the three-way thermostatically controlled valve (sweat connection) at the top of the heater.

The installation of copper unions or copper alloy unions is recommended on the HOT and COLD water lines, so that the water heater may be easily disconnected for servicing if necessary. These unions must be dielectric (insulating) if you are making steel-copper connections.

A shutoff (ball) valve is present on the *COMBOMAX<sup>MC</sup>* domestic hot water outlet for servicing convenience.

Use only clean copper or approved plastic pipe for water connections. Local codes or regulations shall govern the exact type of material to be used.

Insulate all pipes containing hot water, especially in unheated areas.

Thermometer(s) should be installed to indicate the temperature of the water at or near the outlet of the water heater and storage tank(s), if provided.

### 3.6.2 Expansion tank on the cold water supply line

Determine if a flow check valve, a back flow preventer, a pressure-reducing valve, a water meter or a water softener is present on the cold water supply line.

A flow check valve creates a closed system and prevents the water, as it is being heated, from expanding back into the cold water supply line. Pressure can build up within the water heater, causing the pressure relief valve to operate during a heating cycle. This excessive operation can cause premature failure of the relief valve and possibly of the water heater itself.

Replacing the relief valve will not correct the problem. One method of preventing pressure build-up is to install an expansion tank on the

cold water supply line between the *COMBOMAX<sup>MC</sup>* unit and flow check valve. Contact your installing contractor, water supplier, local plumbing inspector or plumbing supply house for assistance.

### 3.6.3 Recirculation line (if applicable)

If a recirculation line is installed, the return connection should be made to a tee close to the inlet connection on the water heater. A check valve should always be installed in the recirculation line to prevent cold water from entering.

### 3.6.4 Domestic hot water temperature and pressure relief valve

An automatic temperature and pressure relief valve **must** be installed at set-up time. No valve of any type should be placed between the safety relief valve and the water heater. Use a tee to set the relief valve onto the hot water outlet. The pressure rating of the relief valve must not exceed 150 psi.

The BTU per hour rating of the relief valve must equal or exceed the BTU per hour input of the boiler(s) or heat source(s) as recorded on the boiler(s) rating plate. For a circulating tank installation, the separate storage tank(s) must have similar protection.

Connect the outlet of the relief valve to a suitable open drain, with the discharge at most 6" above the floor, far from any live electrical parts. The discharge line must pitch downward from the valve to allow complete draining and be no smaller than the outlet of the valve. The end of the discharge line should not be threaded or concealed and should be protected from freezing. No valve of any type, restriction or reducer coupling should be installed in the discharge line. Local codes shall govern the installation of relief valves.

### 3.6.5 Thermostatically controlled mixing valve (included)

For general-purpose hot water requirements in a domestic environment, a thermostatically controlled mixing valve is recommended to reduce the risk of scald injury. Contact a licensed plumber or the local plumbing authority for further information. Adjust the mixing valve to the lowest required temperature setting.

## 3.7 BOILER WIRING

The boiler cabling and grounding must conform to local codes or, in their absence, to the National Electrical Code.

Power must be provided by a 120/240 volt (single phase, 60 Hz) circuit, appropriately fused and with 3-wire plus ground cabling of sufficient gage. The fuse and cabling gauge may be determined from the boiler rating plate.

## 3.8 CIRCULATOR WIRING

The *COMBOMAX<sup>MC</sup>* heating pump (120 Vac, 1/25 Hp) is connected to the C&C terminals on the boiler electrical panel. The control circuit is designed to start the pump upon receiving a heating signal from the thermostat or priority aquastat.

## 3.9 CONNECTING THE THERMOSTAT

### 3.9.1 240V models

#### 3.9.1.1 Single heating zone

Connect the low-voltage thermostat to the T&T terminals on the *COMBOMAX<sup>MC</sup>* electrical panel (**DO NOT apply current to these terminals**). (see figure 10).

#### 3.9.1.2 Zone valve zoning

Connect the low-voltage thermostat to the zone valve. The components must be wired such that, upon a heating signal from a thermostat, only the corresponding zone valve will be actuated and will in turn activate the *COMBOMAX<sup>MC</sup>* circulator relay. Connect the zone valve switch to the T&T terminals on the *COMBOMAX<sup>MC</sup>* electrical panel (**DO NOT apply current to these terminals**). See figures 9 and 10.

The transformer used to power the zone valves must be of sufficient capacity to handle the load represented by all zone valves.

#### 3.9.1.3 Multiple circulator zoning

Connect the low-voltage thermostat to the relay (Honeywell #RA-889, RA-89A). The components must be wired such that, upon a heating signal from a thermostat, only the corresponding circulator will be activated. See figure 9.

## 3.10 PRIORITIZING TERMINAL POST

The K&K terminals on the electrical panel create a dry contact when the domestic hot water priority aquastat contact closes.



### 3.11 BI-ENERGY SETUP

To take advantage of a special domestic electric utility rate, your *COMBOMAX<sup>MC</sup>* boiler can be combined with an existing oil or gas-fired furnace. Please contact your utility to make sure your building is eligible and to find out about the new wiring configuration. Please refer to figures 7 and 8 for the set-up required.

The CBE-EM bi-energy switching control (available as an option) is especially designed to satisfy utility requirements. The CBE-EM control selects the cheapest energy source according to the outdoor temperature, the indoor temperature setting and any signal provided by the utility.

The CBE-EM bi-energy control starts up the oil burner upon receiving the appropriate signal, even if the thermostat is sending no heating signal. The oil burner stops when the boiler reaches its high-limit point. For this reason, the plumbing system must be equipped with a flow check valve or zone valves.

The 3-way zone valve (1" NPT F) which comes with the CBE-EM control, directs the heating water to the oil burner or the *COMBOMAX<sup>MC</sup>* unit depending on the signal sent to it by the external bi-energy sensor. Thus, your oil burner can cool down while eliminating energy losses up the chimney or by conduction in the furnace room .

## Section 4 : Operation

### SAFETY PRECAUTIONS

Before operating this water heater, be sure to read and follow these instructions, as well as the warnings printed in this manual. Failure to do so can result in unsafe operation of the water heater resulting in property damage, bodily injury, or death. Should you have any problems reading, following or difficulty in understanding the instructions in this manual, STOP, and get help from a qualified person.

**Do not turn on the water heater unless it is filled with water. Do not turn on water heater if cold water supply shut-off valve is closed.**

Once the plumbing and electrical connections are completed, your COMBOMAX<sup>MC</sup> unit is ready for automatic operation.

#### 4.1 FILLING THE TANK

Open the outlet valve (in a zone valve system, manually open the zone valves).

Open the boiler inlet valve. Bleed the air from the boiler tank by opening the safety valve atop the boiler while you are filling the tank.

Leave all valves open. Reset the zone valves to automatic operation. Check for leaks and repair if necessary.

Bleed the air from all zones if required. Check the boiler pressure gauge. A pressure reading between 15 and 20 psi is normal for most installations.

#### 4.2 FILLING THE HEATING COIL

Make sure all drain cocks are closed.

Open the nearest domestic hot water tap as well as any control valve on the water heater outlet (the copper tube atop the boiler).

Open the cold water inlet valve on the heater inlet tube. (the copper tube on the left side of the unit).

Close the domestic hot water tap as soon as water flows out of it. Fix any leaks

Open all other hot water taps fed by this heating coil to bleed the air trapped behind them.

#### 4.3 ADJUSTING THE AQUASTATS

Once all air has been bled from the system and all components (valves, bleeders, controls) have been properly adjusted, the boiler can be put into operation. Never operate the boiler before these adjustments are complete.

Bear in mind safety and energy-saving considerations when adjusting the boiler water temperature with the aquastats. It is most energy-efficient to set them as low as possible, in a manner consistent with your heating needs. **However, a minimum temperature of 160°F is recommended for domestic hot water production.**

Each aquastat controls a boiler stage (in the 240V model, each element has its own aquastat). Adjust the setting of each aquastat by turning the dial scaled in degrees Celsius and Fahrenheit. See figure 10 for aquastat identification.

Set the first aquastat to the highest outlet temperature required by the heating system. Thermo 2000 inc. recommends a setting of 180°F.

Adjust the second aquastat 1°F to 20°F below the first aquastat setting. Usually, a setting 5°F below that of the first aquastat, or 175°F, provides good results in a system designed for a 20°F temperature drop between the tank inlet and outlet.

Proceed in a similar manner for the 3rd and 4th aquastats, which will result in settings of 170°F and 165°F. Thus, the number of elements in operation will increase (or decrease) according to the settings and the drop (or rise) in the heating water temperature.

The domestic hot water priority aquastat should be adjusted to a setting 5°F below that of the last stage or 4<sup>th</sup> aquastat, i.e., 160°F.

At system start-up (on the first heating day of the season), it may take quite some time for the boiler water to reach its operating temperature. Check the thermo manometer.

Adjust the boiler aquastats as required. Please note that lowering the setting will not have an immediate effect as the heat stored in the boiler water must first be consumed. Check the boiler water temperature periodically. Further adjustments may be required as the system goes through several space and water heating cycles.

**Note:** The maximum setting for the boiler outlet temperature is 190°F.

#### 4.4 STARTUP PROCEDURE

1. Fill tank and coil as described in sections 4.1 and 4.2.
2. Adjust temperature levels as described in section 4.3
3. Set domestic thermostat level(s) below room temperature.
4. Activate boiler breakers.
5. The main boiler contact should close and all elements should turn on, along with their pilot lights.
6. The circulator should start up and the 3-way valve should switch to the A side.
7. Boiler temperature should rise.
8. Circulator stops and the 3-way valve switches to the B side when boiler temperature exceeds the setting of the domestic hot water priority aquastat.
9. Boiler temperature rises and the elements and corresponding pilot lights turn off one after the other as their temperature setting is reached.
10. When all elements are off, increase the setting of the domestic thermostat(s) to a point above room temperature.
11. Circulator should start up following a delay period.
12. Heating elements should turn back on as their temperature setting is reached; this could take a few minutes.
13. Circulator runs as long as a demand exists for heating. When circulator turns off ...
14. Boiler temperature rises. Heating elements and corresponding pilot lights should turn off as their temperature setting is reached.

Thus, boiler power requirements depend on heating demand within the building. If only one heating element is required to satisfy the demand, only one is activated ; if two are required, two are activated, etc ... You thus

avoid excessive wear and tear on the components due to numerous on-off cycles and reduce your total heating costs.

#### 4.5 DOMESTIC HOT WATER STARTUP

Maximum boiler water temperature is 190°F. This should be 20°F to 40°F above the desired temperature for domestic hot water. In practice, the boiler water temperature should be between 160°F and 180°F.

### DANGER

---

**An excessively high setting can cause scalding. Use the thermostatically controlled mixing valve included with the unit to lower the domestic hot water temperature and thus the risk of injury.**

---

When the boiler water temperature falls below the setting of the domestic hot water priority aquastat, the 3-way valve switches to side A and the circulator starts up.

When the boiler water temperature reaches the setting of the domestic hot water priority aquastat, the 3-way valve returns to side B unless other zones are calling for heat. The heating elements remain on until they reach their set points. It is normal to observe the boiler cycling on and off close to the highest set point, particularly if a single zone is calling for heat.

Considerable time may elapse from a cold start to the moment when the highest set point is reached. Check the domestic hot water temperature as soon as the first heating cycle is complete.

Lowering the set points has no immediate effect. The boiler water heat must first be transferred to the coil. Additional checks will be necessary at the end of successive heating cycles. Further adjustments may be required as time goes by.

The domestic hot water priority aquastat is set at its minimum at shipping time. It can be increased to 190°F for commercial use. Remember that domestic hot water hotter than 125°F can cause scalds. Use this minimum setting as a starting point for any further adjustments. **Normally, the domestic hot water priority aquastat is set to 5°F below the lowest heating element aquastat set point.**

#### **4.6 ADJUSTING THE MIXING VALVE**

A thermostatically controlled mixing valve works automatically thanks to the thermostatic element controlling the mix of very hot and cold water as required to provide safe domestic hot water under variable conditions.

To adjust the mixing valve setting, carefully open a hot water tap. Protect yourself against the possibility of scalding. Measure the hot water temperature and adjust it with the mixing valve, following the manufacturer's instructions. Lock the adjusting valve in place at the proper setting.

A higher boiler water temperature setting is now possible thanks to this moderating effect. The boiler water in the *COMBOMAX<sup>MC</sup>* tank acts as a buffer and increases the boiler efficiency as well as the amount of domestic hot water produced.

To increase the ad hoc or general hot water production capacity, first adjust the domestic hot water priority aquastat setting (e.g., from 140°F to 180°F), then the mixing valve setting (e.g., from 90°F to 120°F).

Some sanitary uses may require different setting ranges or dedicated piping.



## Section 5 : Maintenance

Regular boiler maintenance will ensure trouble-free service for many years. It is recommended that you set up and follow a maintenance program. All components fail eventually. The use of incorrect replacement parts or disregarding safety procedures and warnings during repairs may reduce the boiler safety level and shorten its useful life.

The owner should set up the following maintenance program.

### 5.1 BOILER WATER PIPING :

- Annual visual inspection.

Check for leaks close to connections, unions and valves. Repair as needed.

### 5.2 BOILER CIRCUIT SAFETY VALVE:

- Monthly inspection.

To be checked manually to ensure safety and proper operation. Air trapped in the boiler is bled.

Make sure the water is discharged to a floor drain and that no bystander is splashed. Use the lever to open the safety valve. Hot water should come flowing out. Upon releasing the lever, the safety valve should shut tight. If it does not, it must be replaced by an identical or equivalent model. Never plug a safety valve.

### 5.3 DOMESTIC PIPING :

- Annual visual inspection.

Check for leaks close to connections, unions and valves. Repair as needed.

### 5.4 DOMESTIC CIRCUIT SAFETY VALVE (TEMPERATURE & PRESSURE):

- Annual inspection.

To be checked manually to ensure safety and proper operation. Air trapped in the boiler is bled.

Make sure the water is discharged to a floor drain and that no bystander is splashed. Use the lever to open the safety valve. Hot water should come

flowing out. Upon releasing the lever, the safety valve should shut tight. If it does not, it must be replaced by an identical or equivalent model. Never plug a safety valve.

### 5.5 SCALE BUILD-UP :

- Monthly inspection.

This problem occurs infrequently under very specific conditions. The main symptom is a drop in domestic water pressure. A water softener will solve the problem.

A proper chemical cleaning is a more efficient solution. A scale dissolving product may be used, paying careful attention to the manufacturer's recommendations. Do not use muriatic or hydrochloric acid-based products. Carefully flush the products after use. Contact your plumber to remove scale build-up from the coil.



### WARNING

---

**The manufacturer's warranty DOES NOT cover problems caused by improper installation or maintenance. If the safety valve opens periodically, it may be due to the expansion tank. Immediately call a qualified technician to appraise and repair the problem.**

**NOTE: To prevent tank breakage, trapped air must periodically be bled from it by opening the safety valve.**

---



### DANGER

---

**Before manually opening the safety valve, make sure no bystander will accidentally be splashed by the hot water. The discharged water should be directed to a floor drain to prevent scalding and damage.**

---

## THERMO 2000 INC.

---

500, 9<sup>ième</sup> Avenue, C.P. 639, RICHMOND (QUÉBEC) JOB 2HO  
TÉL.: (819) 826-5613 FAX: (819) 826-6370



## General Safety Precautions

Be sure to read and understand the entire Use & Care Manual before attempting to install or operate this **COMBOMAX<sup>MC</sup>** unit. Pay particular attention to the following General Safety Precautions. Failure to follow these warnings could cause property damage, bodily injury or death. Should you have any problems understanding the instructions in this manual, **STOP**, and get help from a qualified installer or technician.

To meet commercial hot water needs, the aquastat on this water heater is adjustable up to 190°F. However, water temperatures over 125°F can cause severe burns instantly or death from scalds. 125°F is the preferred starting point for setting the control to supply general-purpose hot water.

Safety and energy conservation are factors to be considered when setting the water temperature on the aquastat. The most energy efficient operation will result when the temperature setting is the lowest that satisfies requirements.


Maximum water temperature occurs just after burner or the energy source has shut off. To find hot water temperature being delivered, turn on a hot water faucet and place a thermometer in the hot water stream.

The following chart details the relationship of water temperature and time with regard to scald injury and may be used as a guide in determining the safest water temperature for your applications.

TIME TO SCALDING VS TEMPERATURE RELATIONSHIP	
Temperature	Time to scalding
120°F	Over 5 minutes
125°F	1-1/2 to 2 minutes
130°F	About 30 seconds
135°F	About 10 seconds
140°F	Less than 5 seconds
145°F	Less than 3 seconds
150°F	About 1-1/2 second
155°F	About 1 second

With kind permission from the Shriners Burn Institute

**! DANGER**



Water temperature over 125°F can cause severe burns instantly or death from scalds.

Children, disabled and elderly are at highest risk of being scalded.

See instruction manual before setting temperature at water heater.

Feel water before bathing or showering.

Temperature limiting valves are available, see manual.

### **! DANGER**

**There is a hot water scald potential if the aquastat is set too high. When this water heater is supplying general purpose hot water requirements for use by individuals, a thermostatically controlled mixing valve for reducing point-of-use water temperature is recommended to reduce the risk of scald injury. Contact a licensed plumber or local plumbing authority for further information.**



Schéma d'installation général/  
General installation

Simple Zone/  
Single Zone













-  Réducteur de pression/  
Reducing valve
-  Valve de mélange thermostatique/  
Thermostatic mixing valve
-  Anti retour/  
Back flow preventer
-  Pompe/  
Pump

Figure 2

-  Tuyauterie chauffage/  
Boiler piping
-  Tuyauterie eau domestique/  
Domestic piping
-  Manomètre & thermomètre/  
Manometer & thermometer
-  Valve anti-gravité/  
Flow check valve
-  Valve de sécurité (T&P)  
Safety valve (T&P)
-  Vase d'expansion/  
Expansion tank
-  Valve à bille/  
Ball valve
-  Vent d'air/  
Air vent

Plinthes à ailettes/  
Finnes-Tube baseboard

Eau froide domestique/  
Domestic cold water supply

Eau chaude domestique/  
Domestic hot water mixed

Valve de sécurité (T&P)/  
Safety valve (T&P)

à ajouter/ to add

Thermostat

L1 L2 N

TT

AB

Valve 3 voies/  
3 way-valve

Tuyauterie eau domestique/  
Domestic water piping

Tuyauterie eau de chauffage/  
Boiler water piping



Schéma d'installation général/  
General installation

Système multizones (valves)/  
Multi-zone system using valves



Réducteur de pression/  
Reducing valve



Valve de zonage électrique/  
Electric zone valve



Valve de mélange thermostatique/  
Thermostatic mixing valve



Anti retour/  
Back flow preventer



Pompe/  
Pump

Figure 3

Tuyauterie chauffage/  
Boiler piping

Tuyauterie eau domestique/  
Domestic piping



Manomètre & thermomètre/  
Manometer & thermometer



Valve anti-gravité/  
Flow check valve



Valve de sécurité (T&P)/  
Safety valve (T&P)



Vase d'expansion/  
Expansion tank



Valve à bille/  
Ball valve



Vent d'air/  
Air vent

Thermostat

Eau froide domestique/  
Domestic cold water supply

Eau chaude domestique/  
Domestic hot water mixed

à ajouter/ to add

L1 L2 N

TT

AB

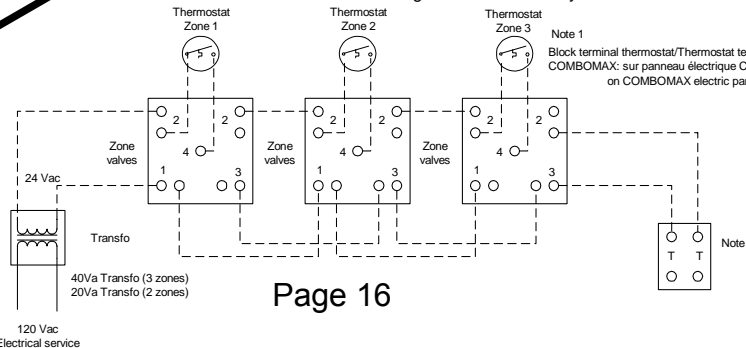
Valve 3 voies/  
3 way-valve

Plinthes à ailettes/  
Finnes-Tube baseboard

Tuyauterie eau domestique/  
Domestic water piping

Tuyauterie eau de chauffage/  
Boiler water piping

Diagramme électrique/ Wiring diagram  
Raccordement de zone valves/ Wiring for zoned valves system



Note 1  
Block terminal thermostat/Thermostat terminal block  
COMBOMAX: sur panneau électrique COMBOMAX/  
on COMBOMAX electric panel





Système primaire/secondaire  
Primary/Secondary system

Système multizones /  
Multi-zone system














-  Réducteur de pression/  
Reducing valve
-  Valve de zonage électrique/  
Electric zone valve
-  Valve de mélange thermostatique/  
Thermostatic mixing valve
-  Anti retour/  
Back flow preventer
-  Pompe/  
Pump

Figure 4

-  Tuyauterie chauffage/  
Boiler piping
-  Tuyauterie eau domestique/  
Domestic piping
-  Manomètre & thermomètre/  
Manometer & thermometer
-  Valve anti-gravité/  
Flow check valve
-  Valve de sécurité (T&P)  
Safety valve (T&P)
-  Vase d'expansion/  
Expansion tank
-  Valve à bille/  
Ball valve
-  Vent d'air/  
Air vent

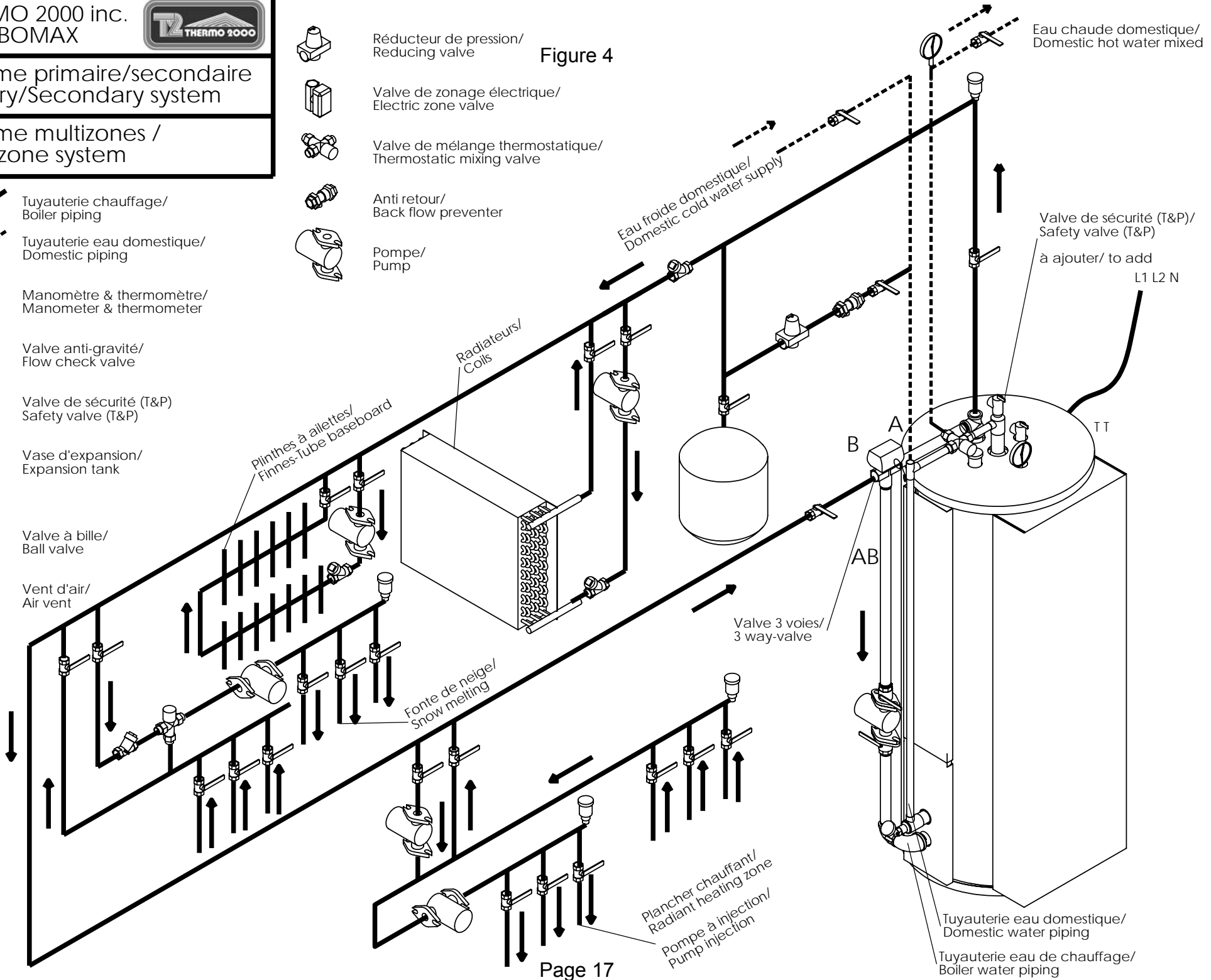
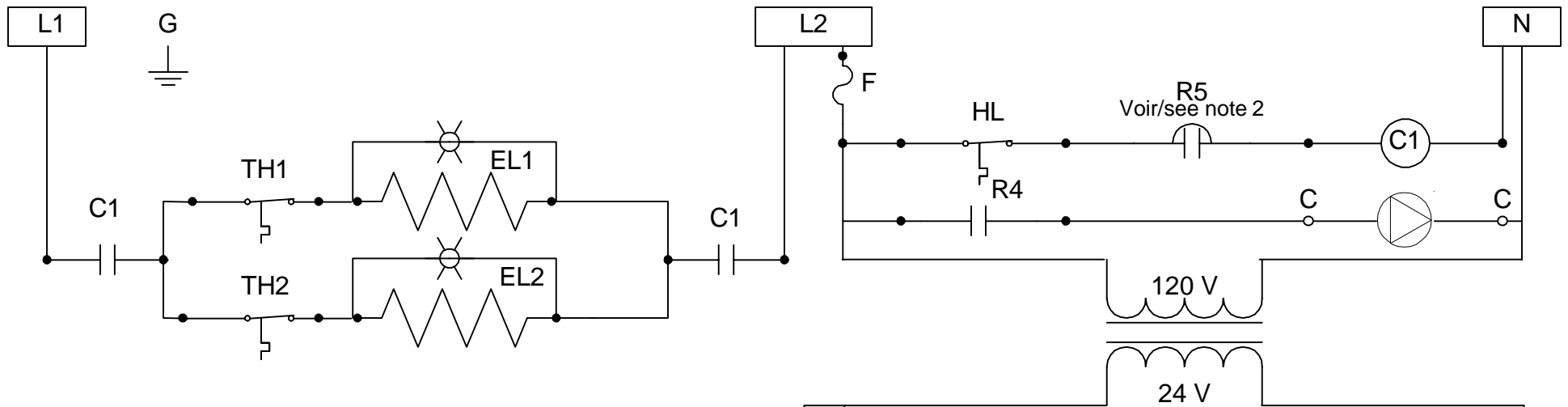


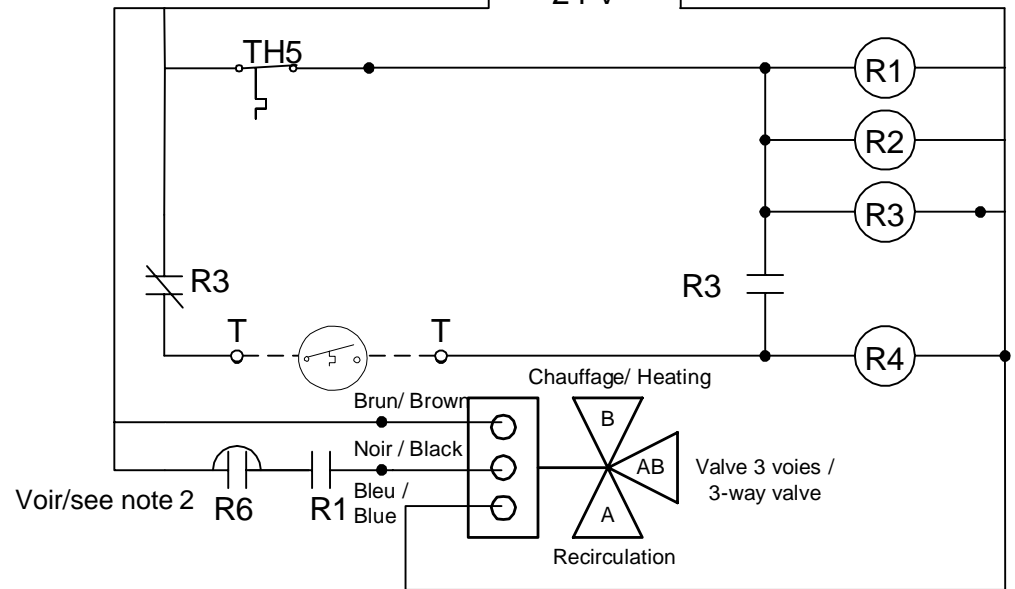
Figure 5

Diagramme électrique/ Wiring diagram  
 COMBOMAX 240V  
 Modèle/Model 6 - 10 KW



Légende/ Legend

	Aquastat		Relais Relay
	Élément chauffant/ Heating element		Lampe témoin Pilot light
	Contacteur de puissance Power relay		Fusible Fuse
	Haute limite Hi-Limit		Cablage en usine/ Factory wiring
	Thermostat		Cablage par l'installateur/ Wiring by others
			Circulateur/ Circulator



Note 1: Bloc terminal (24VAC) pour une installation avec le contrôleur bi-énergie Thermo 2000 modèle: "CBE-EM"/ Terminal block (24 VAC) for an installation with Thermo 2000 dual energy controller model: "CBE-EM"

Note 2: Couper le cavalier lorsque vous utilisez le contrôleur bi-énergie Thermo2000 modèle: "CBE-EM"/ Cut open this jumper when using Thermo 2000 dual energy controller model: "CBE-EM"

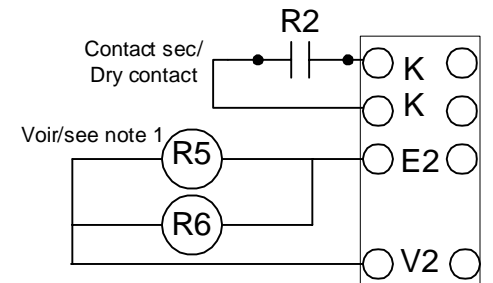
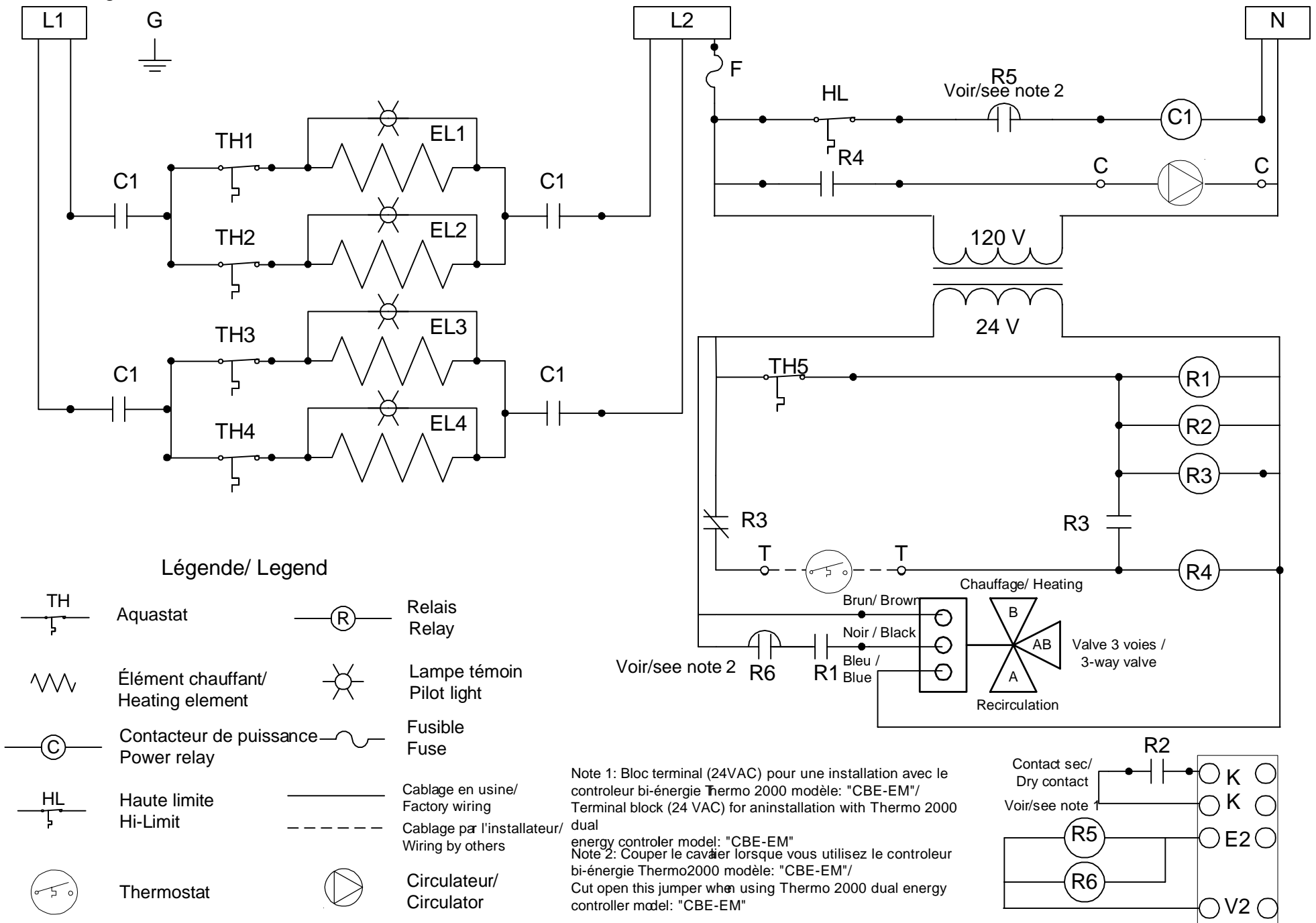


Diagramme électrique/ Wiring diagram  
 COMBOMAX 240V : modèle/ model 15 - 24 KW

Figure 6



Légende/ Legend

- |  |  |  |   |
|--|--|--|---|
|  | Aquastat                               |  | Relais<br>Relay                                 |
|  | Élément chauffant/<br>Heating element  |  | Lampe témoin<br>Pilot light                     |
|  | Contacteur de puissance<br>Power relay |  | Fusible<br>Fuse                                 |
|  | Haute limite<br>Hi-Limit               |  | Cablage en usine/<br>Factory wiring             |
|  | Thermostat                             |  | Cablage par l'installateur/<br>Wiring by others |
|  |  |  | Circulateur/<br>Circulator                      |

Note 1: Bloc terminal (24VAC) pour une installation avec le contrôleur bi-énergie Thermo 2000 modèle: "CBE-EM"/ Terminal block (24 VAC) for an installation with Thermo 2000 dual energy controller model: "CBE-EM"  
 Note 2: Couper le cavalier lorsque vous utilisez le contrôleur bi-énergie Thermo2000 modèle: "CBE-EM"/ Cut open this jumper when using Thermo 2000 dual energy controller model: "CBE-EM"

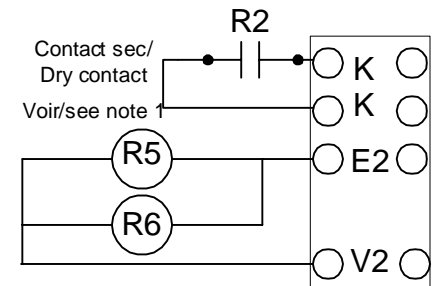


Figure 7  
 Diagramme électrique/ Wiring diagram  
 Contrôle Bi-énergie/ Dual control energy CBE-EM

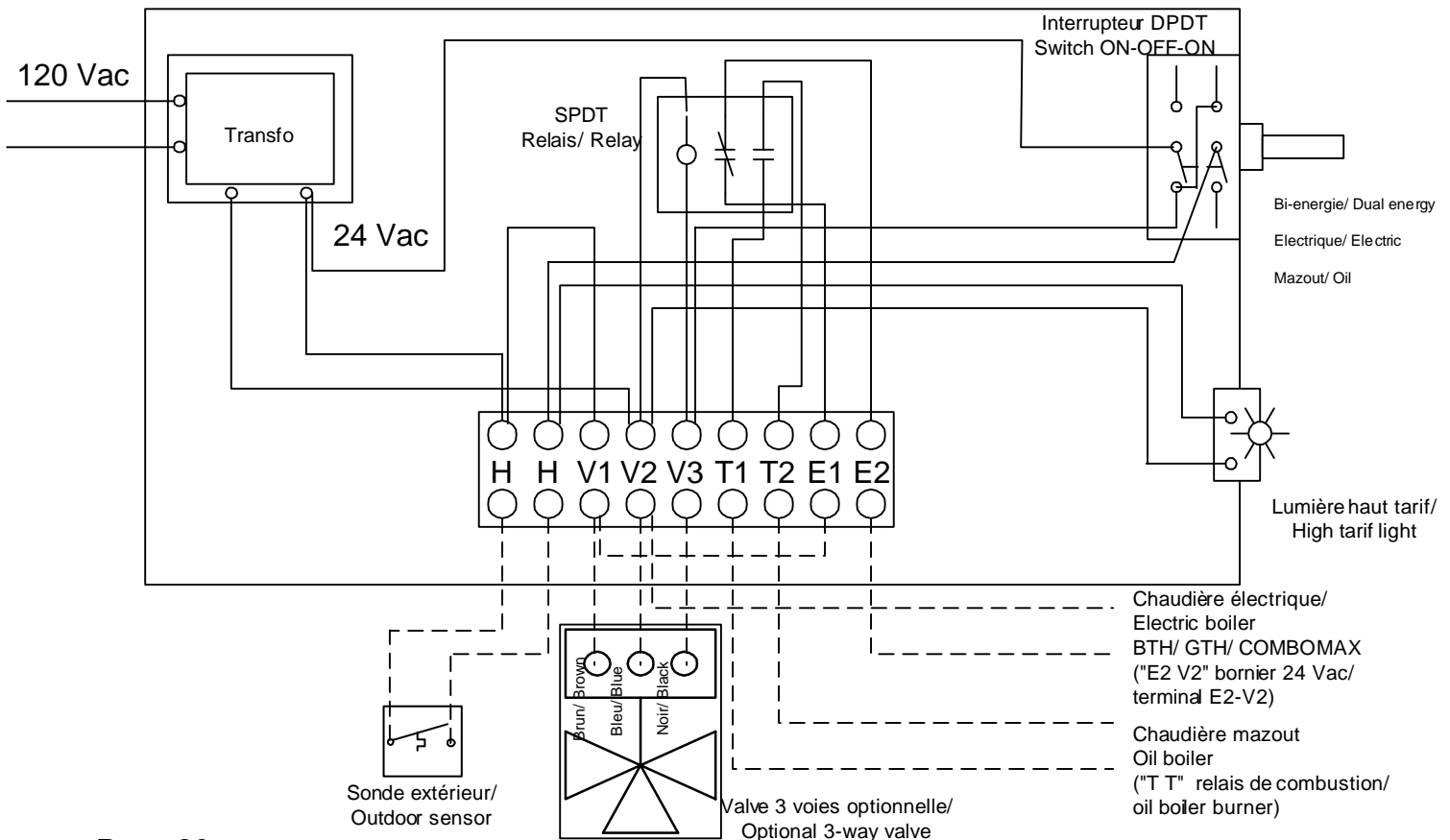
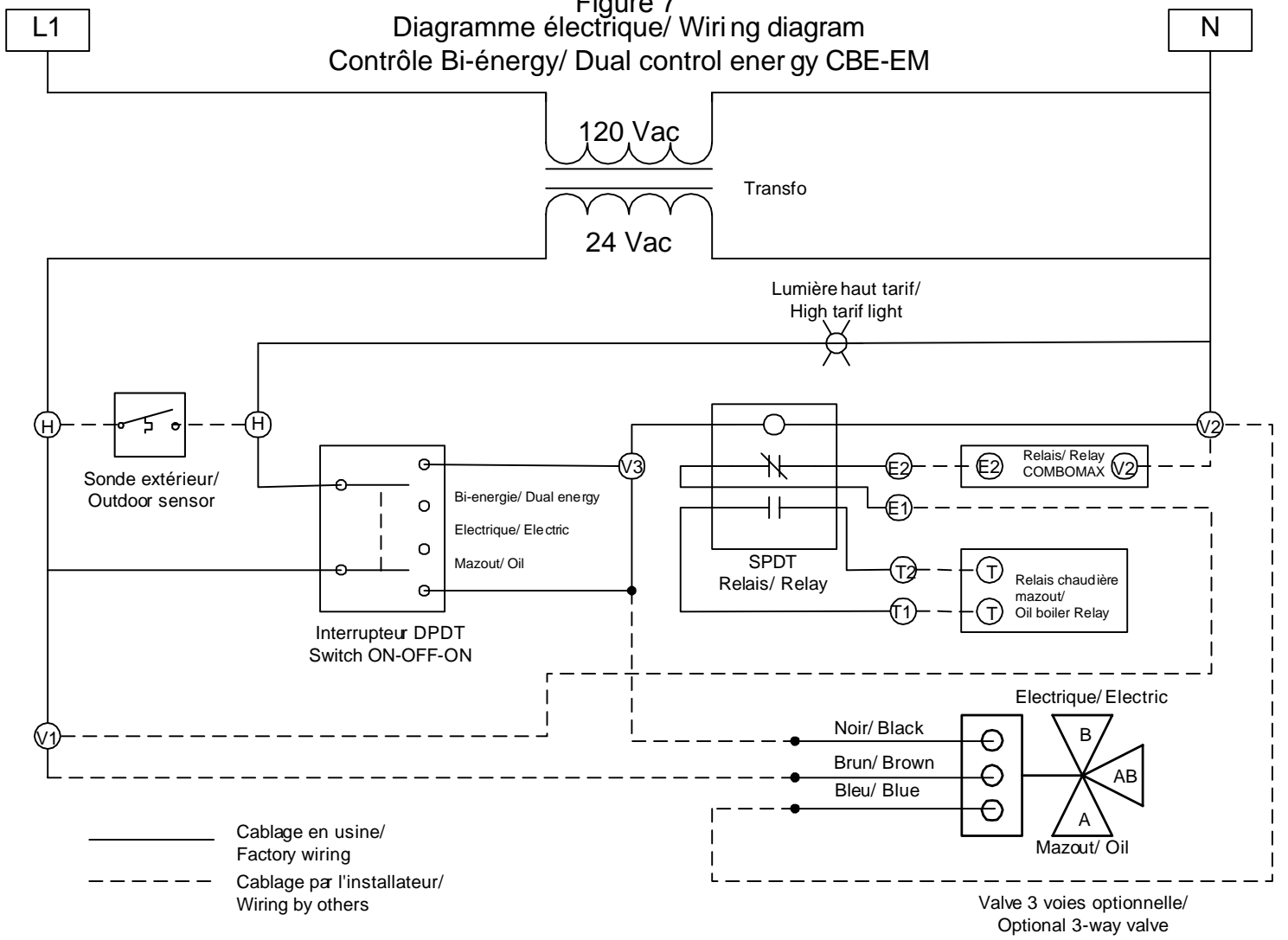




Schéma d'installation général/  
General installation

Bi-énergie avec Valve 3 Voies/  
Dual Energy with 3-way valve

Figure 8

- Tuyauterie chauffage/  
Boiler piping
- Tuyauterie eau domestique/  
Domestic piping
- Manomètre & thermomètre/  
Manometer & thermometer
- Valve anti-gravité/  
Flow check valve
- Valve de sécurité (T&P)  
Safety valve (T&P)
- Vase d'expansion/  
Expansion tank
- Valve à bille/  
Ball valve
- Vent d'air/  
Air vent

- Réducteur de pression/  
Reducing valve
- Valve de mélange thermostatique/  
Thermostatic mixing valve
- Anti retour/  
Back flow preventer
- Pompe/  
Pump

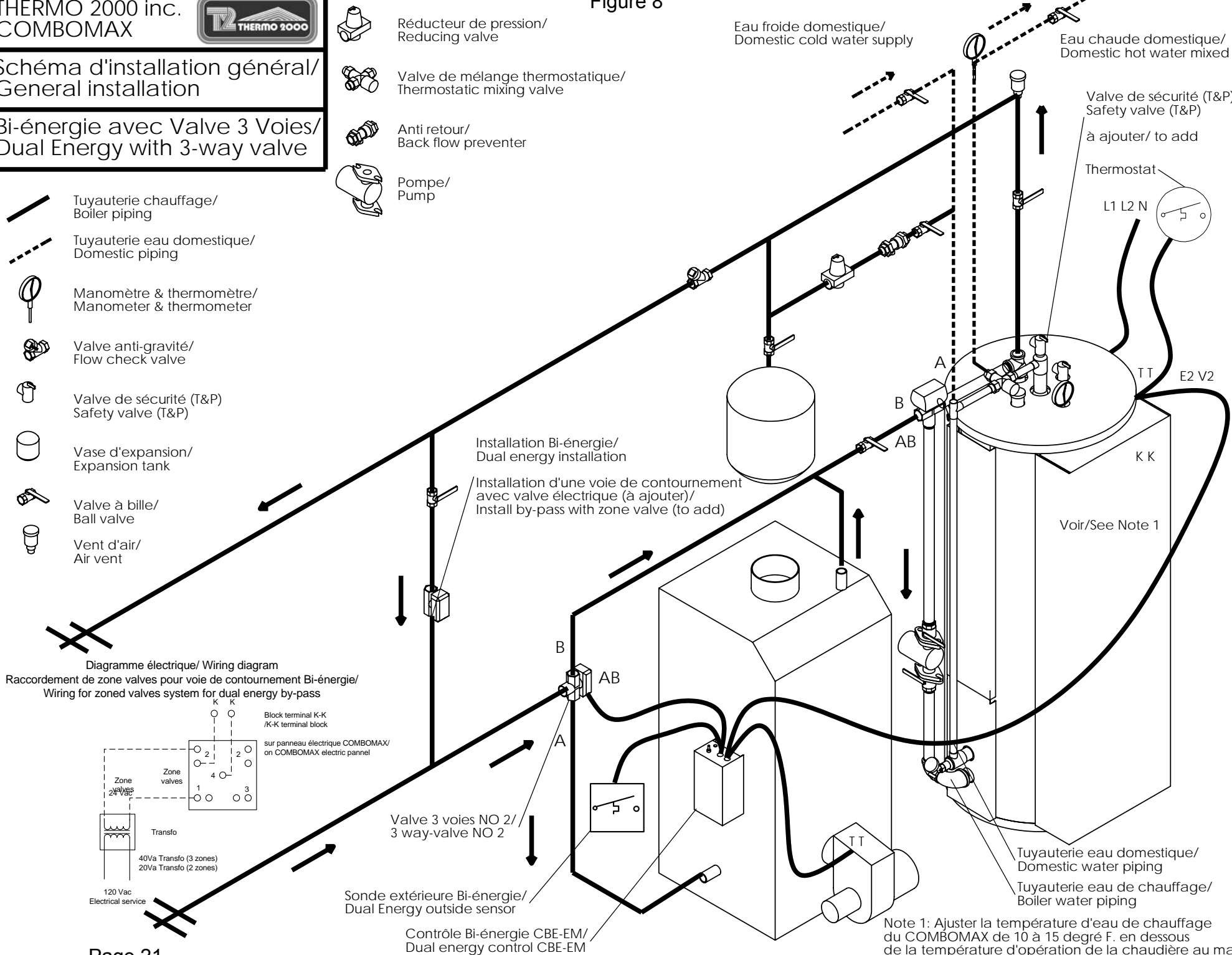
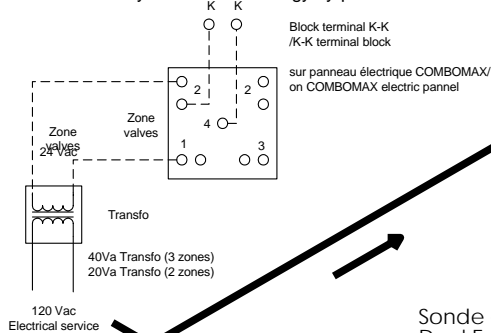


Diagramme électrique/ Wiring diagram  
Raccordement de zone valves pour voie de contournement Bi-énergie/  
Wiring for zoned valves system for dual energy by-pass

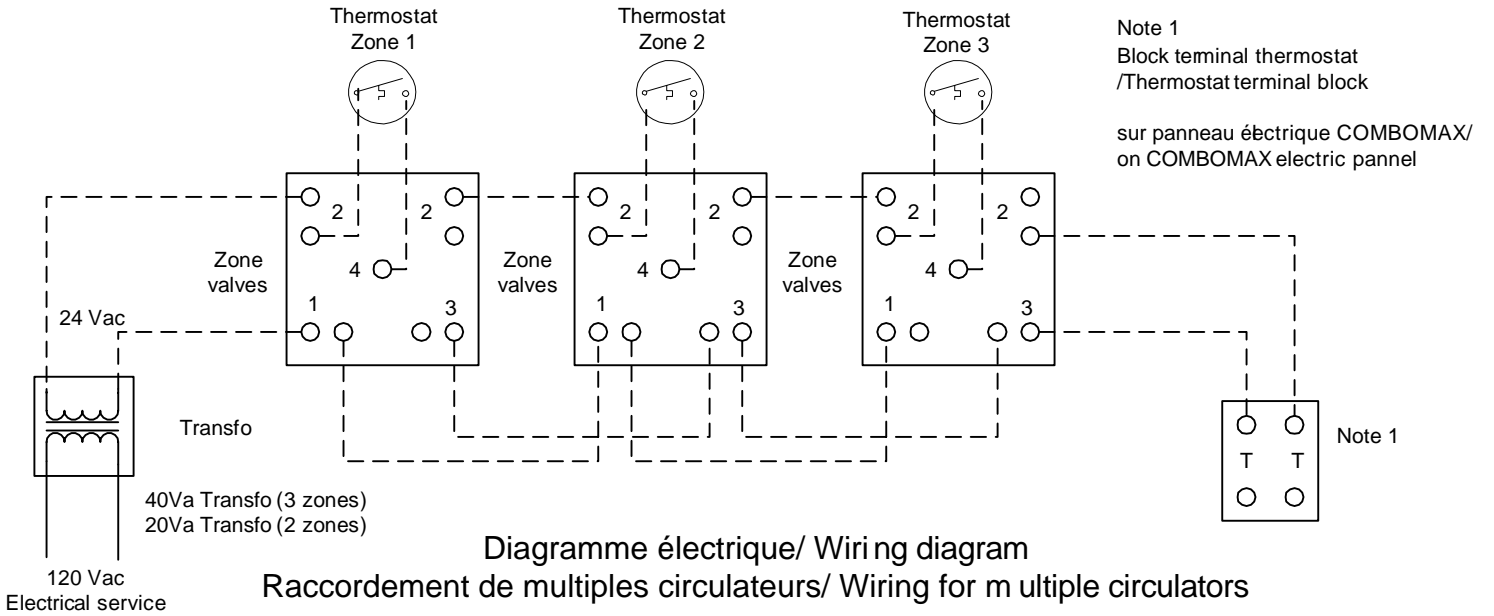


Sonde extérieure Bi-énergie/  
Dual Energy outside sensor

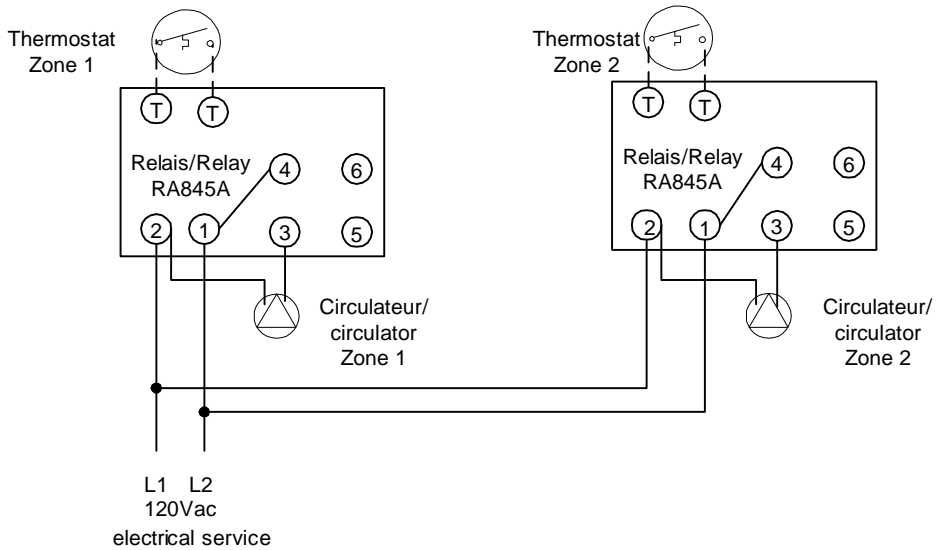
Contrôle Bi-énergie CBE-EM/  
Dual energy control CBE-EM

Note 1: Ajuster la température d'eau de chauffage  
du COMBOMAX de 10 à 15 degré F. en dessous  
de la température d'opération de la chaudière au mazout.

**Figure 9**  
**Diagramme électrique/ Wiring diagram**  
**Raccordement de zone valves/ Wiring for zoned valves system**



**Diagramme électrique/ Wiring diagram**  
**Raccordement de multiples circulateurs/ Wiring for multiple circulators**



**Diagramme électrique/ Wiring diagram**  
**Raccordement de zone valves pour voie de contournement Bi-énergie/**  
**Wiring for zoned valves system for dual energy by-pass**

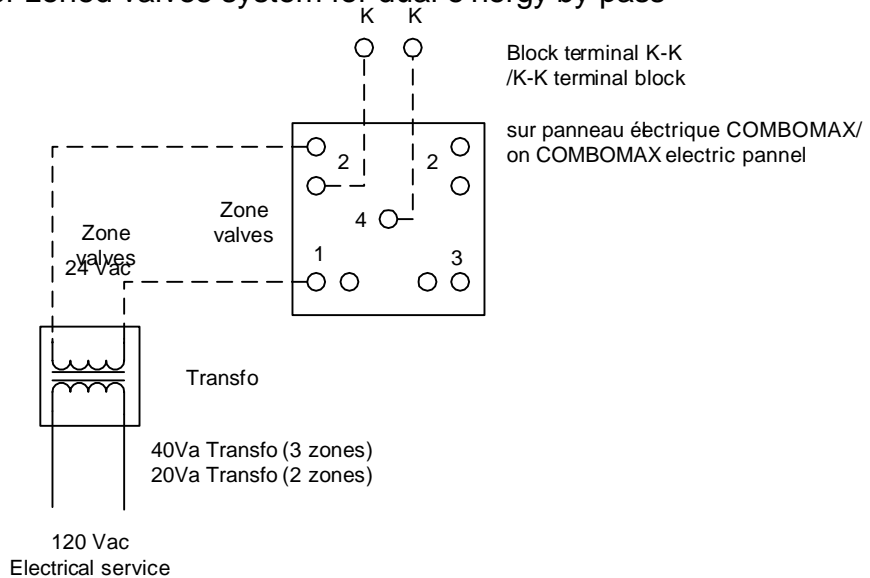


Figure 10

Aquastat  
Priorité DHW/  
DHW priority  
(Sugg: 160F)

Aquastat  
Élément no. 4/  
Element no. 4  
(Sugg: 165F)

Aquastat  
Élément no. 3/  
Element no. 3  
(Sugg: 170F)

Aquastat  
Élément no. 2/  
Element no. 2  
(Sugg: 175F)

Aquastat  
Élément no. 1/  
Element no. 1  
(Sugg: 180F)

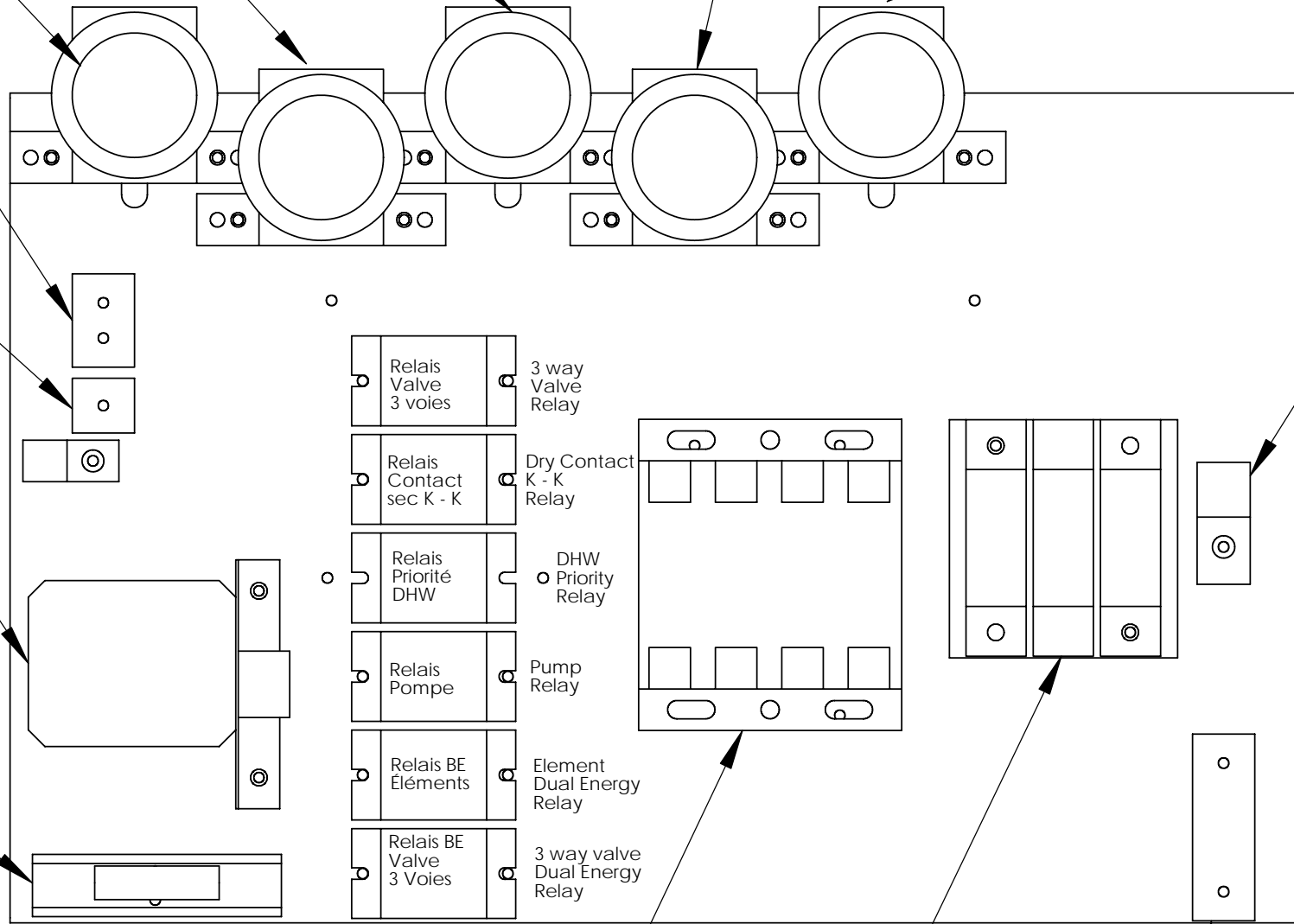
Bornier  
valve 3 voies/  
3 way valve  
terminal block

Bornier/  
Terminal block  
C-C  
(Pompe/ Pump)

Transformateur  
contrôle/  
Transformer  
Control

Fusible  
contrôle/  
Control  
Fuse

Mise à  
la terre/  
Grund



THERMO 2000 inc.



Panneau de contrôle/  
Control panel

COMBOMAX 240V

Contacteur  
principal/  
Main  
Contactor

Bornier de  
raccordement/  
Main terminal  
Block

Bornier/ Terminal block

K-K (contact sec/ Dry contact)  
E2-V2 (Bi-énergie/ Dual Energy)  
T-T (Thermostat)



## COMBOMAX™ LIMITED WARRANTY

### **Warranty Coverage for Residential Installation.**

Thermo 2000 Inc. hereby warrants to the original residential purchaser that the COMBOMAX tank and exchanger (coil assembly) installed in a residential setting shall be free of leaks during normal use and service for a period of fifteen (15) years from the date of purchase as long as the original residential purchaser owns the home in which the unit was originally installed, the ten (10) years in full and years eleven (11) through fifteen (15) prorated 20% each year at suggested retail price. Residential setting shall mean usage in a single-family dwelling in which the consumer resides on a permanent basis. Also, residential setting shall mean use in multiple family dwellings in which one (1) COMBOMAX tank and exchanger is to be used in only one (1) dwelling. In the event that a leak should develop and occur within this limited warranty period due to defective material or workmanship, such leak having been verified by an authorized company representative, Thermo 2000 inc. will repair or replace at our sole option the failed unit with the nearest comparable model at the time of replacement.

The original residential purchaser is responsible for all costs associated with the removal and reinstallation, shipping and handling to and from manufacturing plant. The replacement unit will be warranted for the remaining portion of the original Warranty.

### **Warranty Coverage for Commercial Installation.**

Thermo 2000 Inc. hereby warrants to the original residential purchaser that the COMBOMAX tank and exchanger (coil assembly) installed in a residential setting shall be free of leaks during normal use and service for a period of fifteen (15) years from the date of purchase as long as the original residential purchaser owns the home in which the unit was originally installed, the ten (10) years in full and years eleven (11) through fifteen (15) prorated 20% each year at suggested retail price. Commercial setting shall mean use in other than residential setting stated above in the residential setting definition. In the event that a leak should develop and occur within this limited warranty period due to defective material or workmanship, such leak having been verified by an authorized company representative, Thermo 2000 inc. will repair or replace at our sole option the failed unit with the nearest comparable model at the time of replacement.

The original purchaser is responsible for all costs associated with the removal and reinstallation, shipping and handling to and from Manufacturer. The replacement unit will be warranted for the remaining portion of the original Warranty.

### **Limited one year warranty on all COMBOMAX components & parts**

All other COMBOMAX components & parts are warranted for a period of one (1) year against defects due to defective material or workmanship. The original purchaser is responsible for all costs associated with the removal and reinstallation, shipping and handling to and from Manufacturer. The components, repaired or replaced are warranted for the residual period of the initial warranty on the unit.

### **Exclusions.**

This warranty is void and shall not apply if:

- A) Defects or malfunctions resulting from installation, repair, maintenance and/or usage that are not done in conformity with the manufacturer's installation manual; or

- B) Defects or malfunctions resulting from installation, maintenance, or repair that are not done in accordance with regulations in force; or
- C) Defects or malfunctions resulting from improper installation, maintenance or repair done carelessly or resulting from consumer damage (improper maintenance, misuse, abuse, accident or alteration); or
- D) Installation in which a relief valve (pressure) is not installed or if it is not functioning properly, or when it is not connected to a drain to avoid damage to the property; or
- E) Installation in which liquid circulating in the tank does not remain in closed circuit or installation in which piping is leaking; or
- F) A polybutylene pipe or radiant panel installation without an oxygen absorption barrier is used; or
- G) Installation where the acidity of water is not within the normal Environmental Protection Agency (EPA) (between pH 6.5 – 8.5) guidelines or the domestic water contains abnormal levels of particulate matter or water exceeding 10.5 gpg; or
- H) Your home contains any type of water softener system and the unit is not installed and maintained in accordance with the manufacturer specifications; or
- I) When installed with a low pressure steam boiler, if sludge is allowed to accumulate in the COMBOMAX tank and boiler water acidity is lower than pH 6.5 or higher than pH 8.5; or
- J) The COMBOMAX unit is being subject to non authorized modifications; or
- K) Defects or malfunction resulting of storing or handling done elsewhere than Thermo 2000's manufacturing plant; or
- L) Units on which the serial number is removed or obliterated.

### **Limitations.**

Thermo 2000 shall not be responsible for any damage, loss, and inconvenience of any nature whatsoever, directly or indirectly, relating to the breakdown or malfunction of the unit. This warranty limits its beneficiary's rights. Nevertheless, the beneficiary may have other rights, which vary from state to state.

This warranty replaces any other expressed or implicit warranty and constitutes the sole obligation of Thermo 2000 towards the consumer. The warranty does not cover cost of removal, reinstallation or shipping to repair or replace the unit, nor administration fees incurred by the original consumer purchaser.

Thermo 2000 reserves its rights to make changes in the details of design, construction, or material, as shall in its judgment constitute an improvement of former practices.

This warranty is valid only for installations made within the territorial limits of Canada and the United States.

**In order to receive the benefit of this warranty, the original consumer purchaser must fill in and return the attached registration card within thirty (30) days of date of purchase.**

### **Warranty service procedure**

Only authorized COMBOMAX dealers are permitted to perform warranty obligations. The owner or its contractor must provide Thermo 2000's head office or authorized depot with defect unit together with the following information: COMBOMAX model and serial number, copy of the original sales receipt and owner's identification certificate.

## **THERMO 2000 INC.**

500, 9<sup>ième</sup> Avenue, C.P. 639, RICHMOND (QUÉBEC) JOB 2HO  
TÉL.: (819) 826-5613 FAX: (819) 826-6370