

# KENWOOD

## DDX8032BT DDX8032BTM

---

MONITOR WITH DVD RECEIVER

### INSTALLATION MANUAL

附 DVD 接收机显示器

### 安装说明书

DVD 수신기장착 모니터

### 설치 설명서

Kenwood Corporation

# Accessories

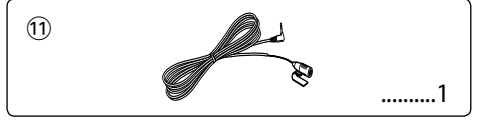
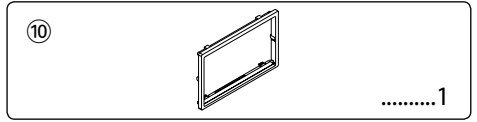
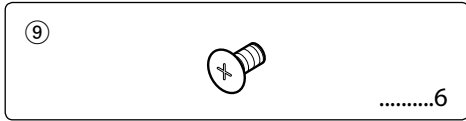
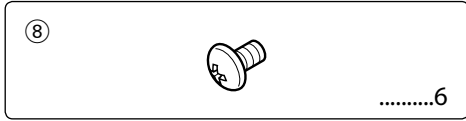
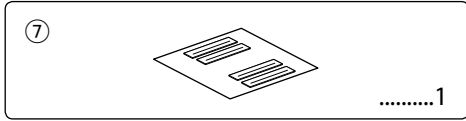
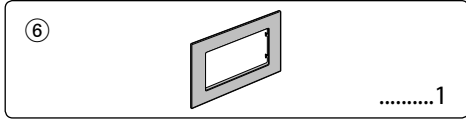
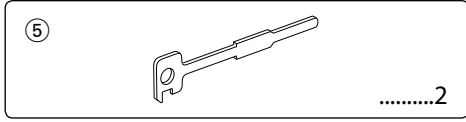
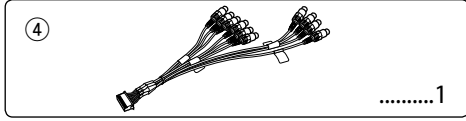
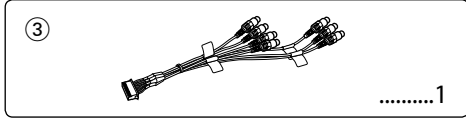
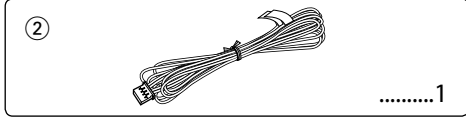
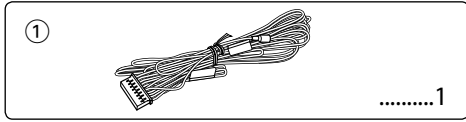

# Installation Procedure

1. To prevent a short circuit, remove the key from the ignition and disconnect the ⊖ battery.
2. Make the proper input and output wire connections for each unit.
3. Connect the speaker wires of the wiring harness.
4. Connect the wiring harness wires in the following order: ground, battery, ignition.
5. Connect the wiring harness connector to the unit.
6. Install the unit in your car.
7. Reconnect the ⊖ battery.
8. Press the reset button.

## ⚠ WARNING

- If you connect the ignition wire (red) and the battery wire (yellow) to the car chassis (ground), you may cause a short circuit, that in turn may start a fire. Always connect those wires to the power source running through the fuse box.
- Do not cut out the fuse from the ignition wire (red) and the battery wire (yellow). The power supply must be connected to the wires via the fuse.



- Mounting and wiring this product requires skills and experience. For safety's sake, leave the mounting and wiring work to professionals.
- Make sure to ground the unit to a negative 12V DC power supply.
- Do not install the unit in a spot exposed to direct sunlight or excessive heat or humidity. Also avoid places with too much dust or the possibility of water splashing.
- Do not use your own screws. Use only the screws provided. If you use the wrong screws, you could damage the unit.
- If the power is not turned ON ("PROTECT" is displayed), the speaker wire may have a short-circuit or touched the chassis of the vehicle and the protection function may have been activated. Therefore, the speaker wire should be checked.
- If your car's ignition does not have an ACC position, connect the ignition wires to a power source that can be turned on and off with the ignition key. If you connect the ignition wire to a power source with a constant voltage supply, as with battery wires, the battery may die.
- If the console has a lid, make sure to install the unit so that the faceplate will not hit the lid when closing and opening.
- If the fuse blows, first make sure the wires aren't touching to cause a short circuit, then replace the old fuse with one with the same rating.
- Insulate unconnected wires with vinyl tape or other similar material. To prevent a short circuit, do not remove the caps on the ends of the unconnected wires or the terminals.

- Connect the speaker wires correctly to the terminals to which they correspond. The unit may be damaged or fail to work if you share the ⊖ wires or ground them to any metal part in the car.
- When only two speakers are being connected to the system, connect the connectors either to both the front output terminals or to both the rear output terminals (do not mix front and rear). For example, if you connect the ⊕ connector of the left speaker to a front output terminal, do not connect the ⊖ connector to a rear output terminal.
- After the unit is installed, check whether the brake lamps, blinkers, wipers, etc. on the car are working properly.
- Mount the unit so that the mounting angle is 30° or less.
- This unit has the cooling fan (page 5) to decrease the internal temperature. Do not mount the unit in a place where the cooling fan of the unit are blocked. Blocking these openings will inhibit the cooling of the internal temperature and result in malfunction.
- Do not press hard on the panel surface when installing the unit to the vehicle. Otherwise scars, damage, or failure may result.
- Reception may drop if there are metal objects near the Bluetooth antenna.



Bluetooth antenna unit

# Connection

**⚠** If you connect the ignition wire (red) and the battery wire (yellow) to the car chassis (ground), you may cause a short circuit, that in turn may start a fire. Always connect those wires to the power source running through the fuse box.

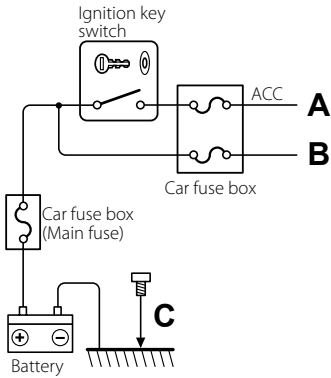

- A** ← Ignition wire (Red)
- B** ← Battery wire (Yellow)
- C** ← Ground wire (Black) ⊖  
(To car chassis)

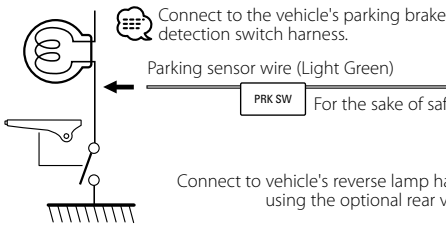
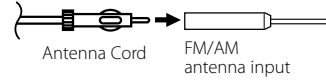

Revers sensor wire (Purple/White)

- To steering remote Steering remote control input (Light Blue/Yellow)
- ⓘ** To use the steering wheel remote control feature, you need to an exclusive remote adapter (not supplied) matches your car is required. When this terminal is not in use, leave its cap on.

- To car light control switch
- Dimmer control wire (Orange/White)
- Connect to the terminal that is grounded when either the telephone rings or during conversation.
- Mute wire (Brown)
- ⓘ** To connect the Kenwood navigation system, consult your navigation manual.
- Depending on what antenna you are using, connect either to the control terminal of the motor antenna, or to the power terminal for the booster amplifier of the film-type antenna.
- Motor antenna control wire (Blue)
- When using the optional power amplifier, connect to its power control terminal.
- Power control wire (Blue/White)
- To "EXT.AMPCONT" terminal of the amplifier having the external amp control function.
- External amplifier control wire (Pink/Black)

**ⓘ** If no connections are made, do not let the cable come out from the tab.

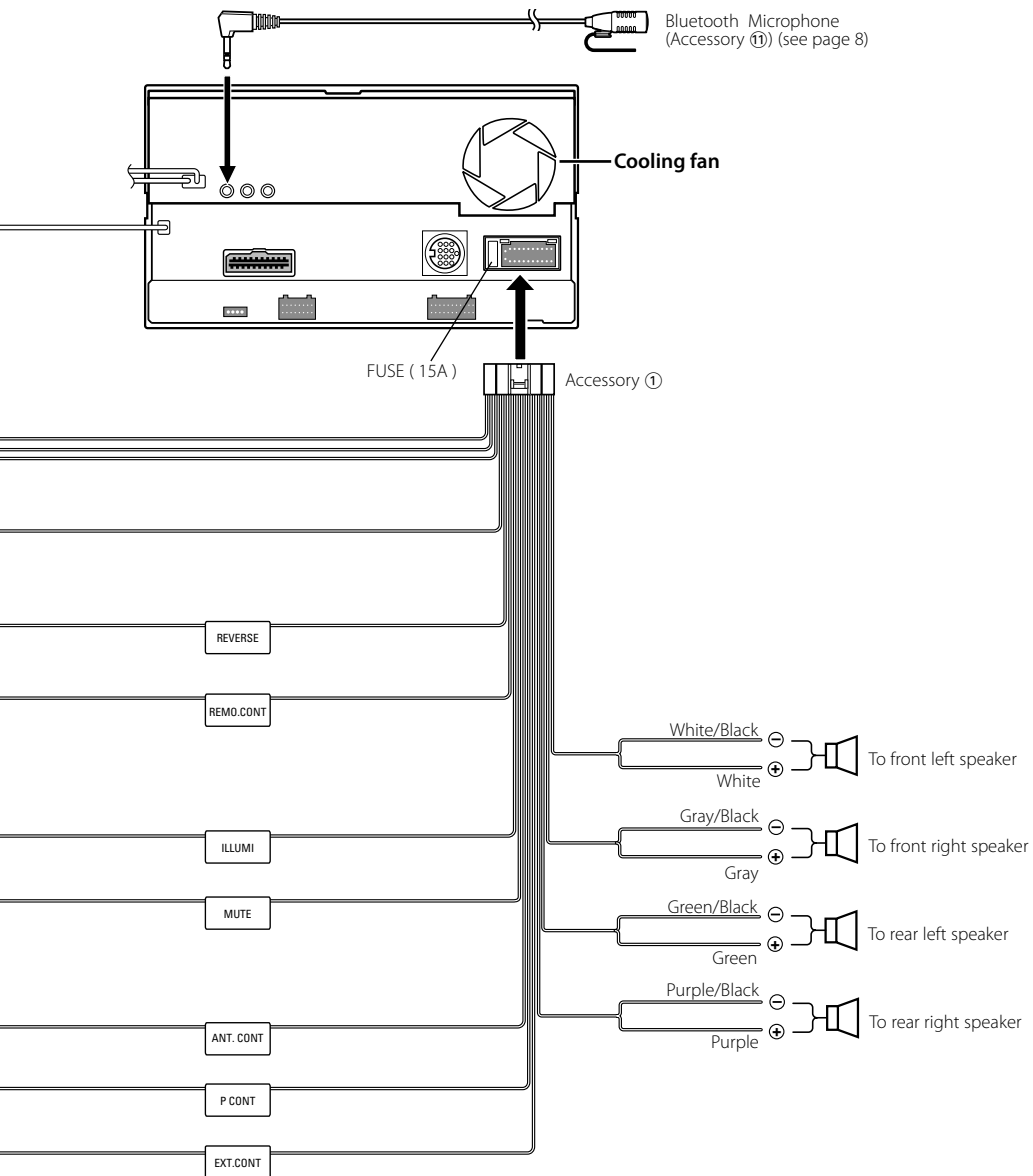

# System Connection

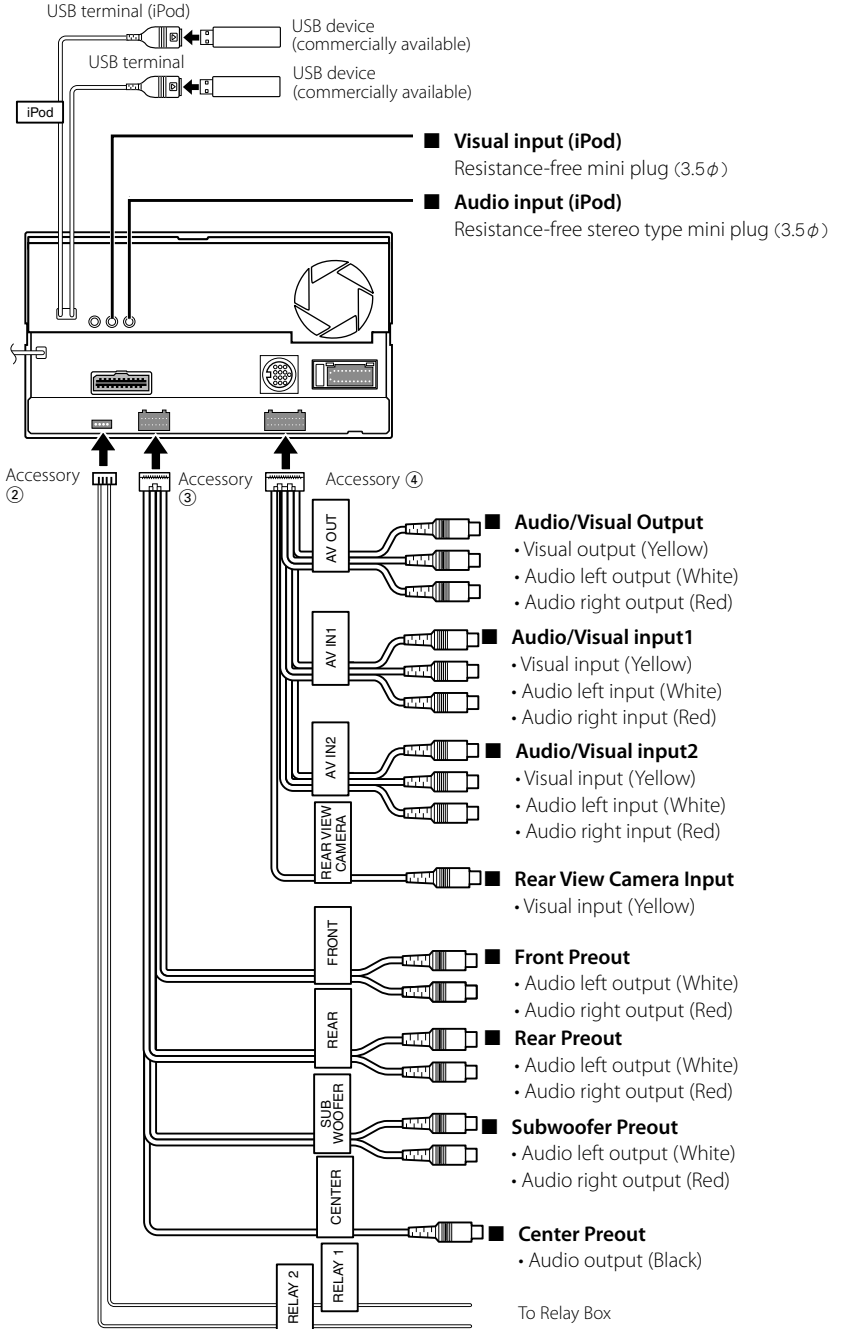

# Optional Accessory Connection

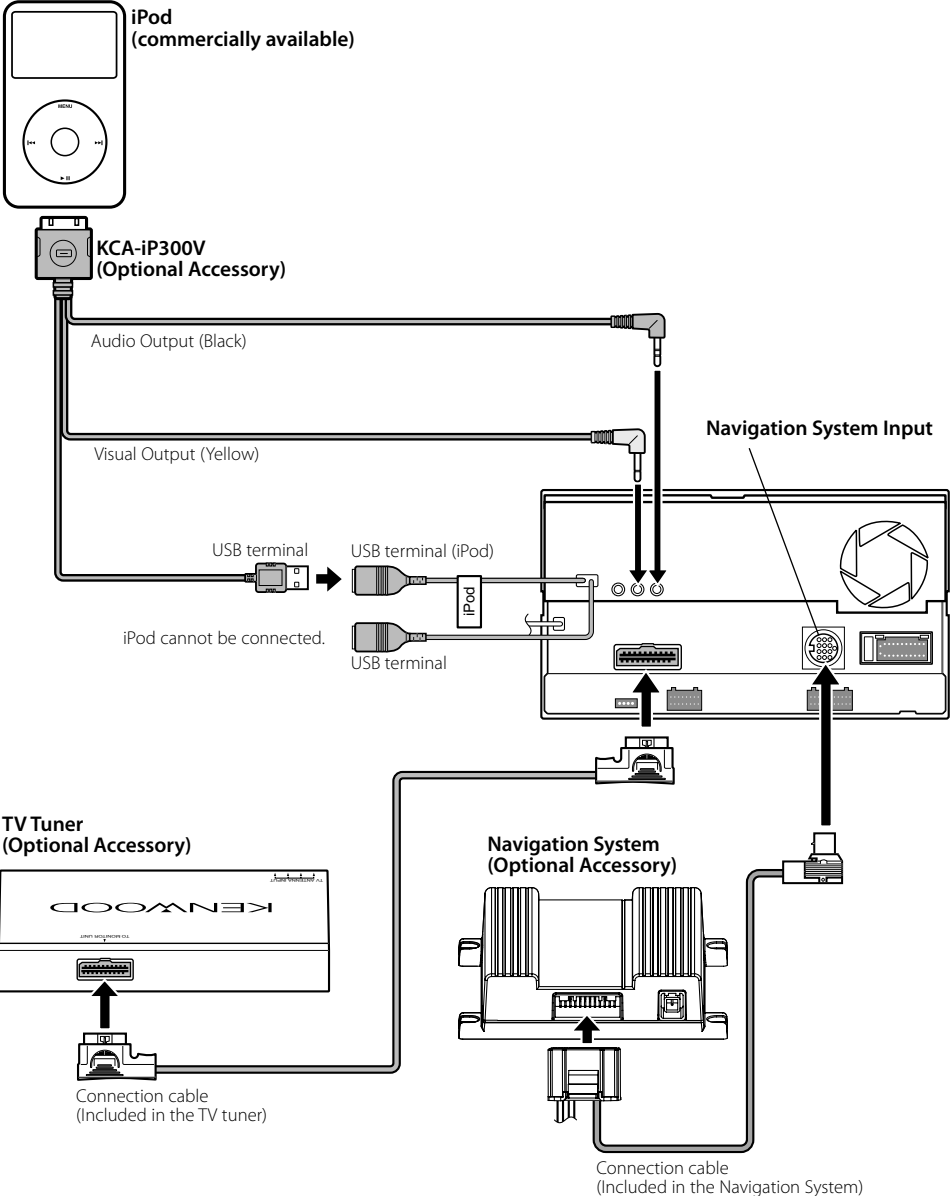

## Installing the Microphone Unit

1. Check the installation position of the microphone (accessory ⑪).
2. Remove oil and other dirt from the installation surface.
3. Install the microphone.
4. Wire the microphone cable up to the hands-free box with it secured at several positions using tape or the like.

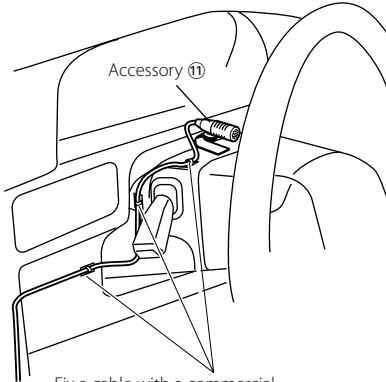

Fix a cable with a commercial item of tape.

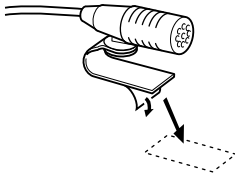

Peel the release coated paper of double-face adhesive tape to fix on the place shown above.



Adjust the direction of the microphone to the driver.

 Install the microphone as far as possible from the cell-phone.

## Installing the Escutcheon

### For General Motors

1. Cut out accessory ⑥ to meet the shape of the opening of the center console.
2. Attach accessory ⑥ to the unit.

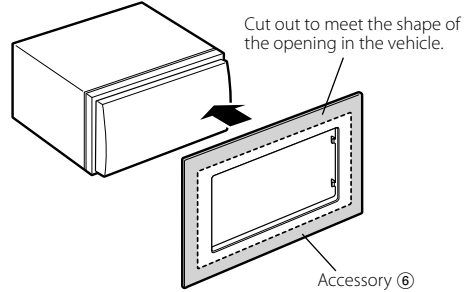

### For Volkswagen

1. Attach accessory ⑩ to the unit.

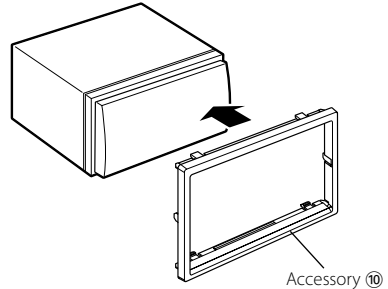



## For Toyota/Scion

1. Cut out accessory ⑥ as illustrated.

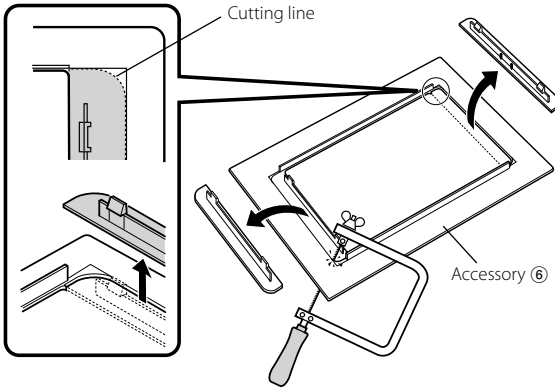

2. Fold double-sided adhesive (accessory ⑦) along the slit and attach it to accessory ⑥ cut-out against the center rib as illustrated. Use 2 pieces of accessory ⑦ for 1 accessory ⑥ cut-out.
3. Attach accessory ⑥ cut-out to the unit.

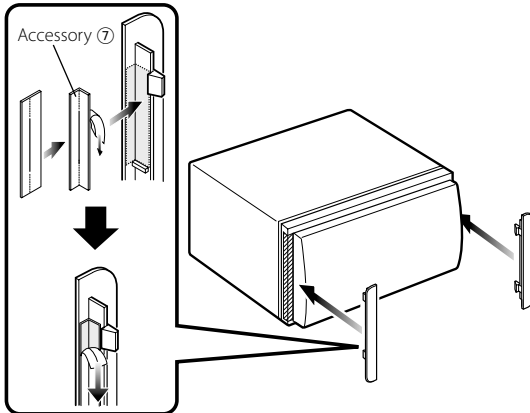

## Installation for Monitor/Player Unit

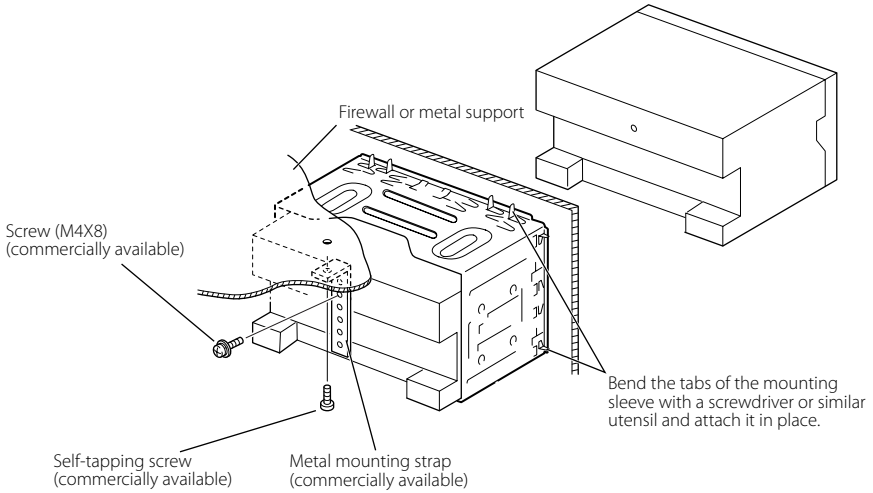

Make sure that the unit is installed securely in place. If the unit is unstable, it may malfunction (eg, the sound may skip).

## Installation on Toyota, Nissan or Mitsubishi Car using Brackets

Accessory ⑧ (M5x6mm)  
or Accessory ⑨ (M5x7mm)

Car Bracket

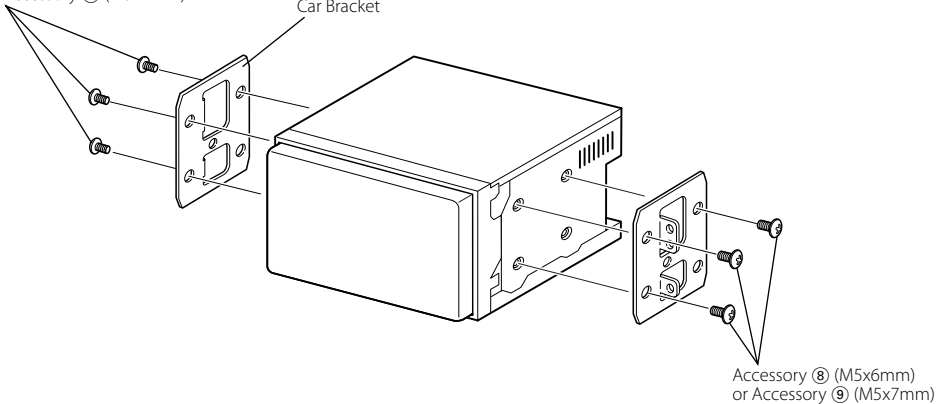

# Removing Monitor/Player Unit

## Removing the Hard Rubber Frame (escutcheon)

1. Engage the catch pins on the removal tool ⑤ and remove the two locks on the lower level. Lower the frame and pull it forward as shown in the figure.

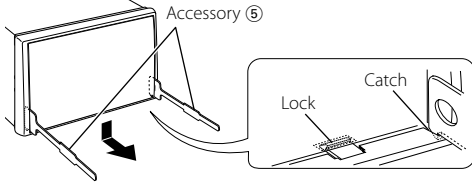

- The frame can be removed from the top side in the same manner.

2. When the lower level is removed, remove the upper two locations.

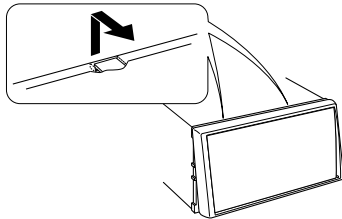

## Removing the Unit

1. Remove the hard rubber frame by referring to the removal procedure in the section <Removing the Hard Rubber Frame>.
2. Remove the Hex-head screw with integral washer (M4 x 8) on the back panel.
3. Insert the two removal tools ⑤ deeply into the slots on each side, as shown.

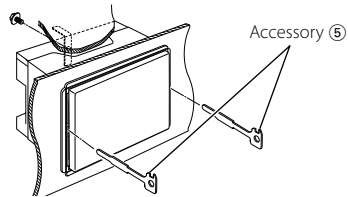

4. Lower the removal tool toward the bottom, and pull out the unit halfway while pressing towards the inside.

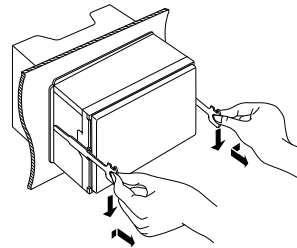

- Be careful to avoid injury from the catch pins on the removal tool.

5. Pull the unit all the way out with your hands, being careful not to drop it.

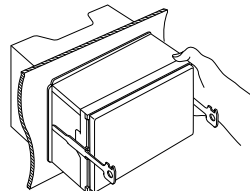

# 附件

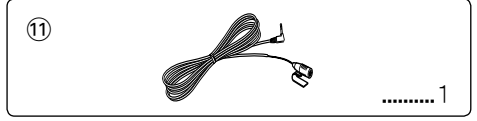
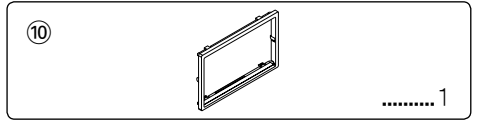
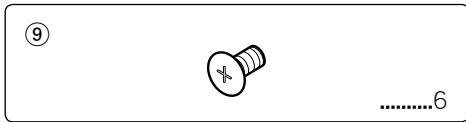
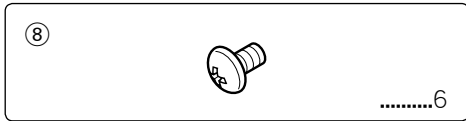
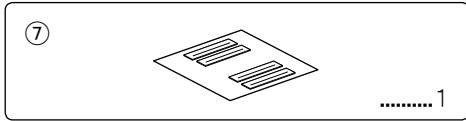
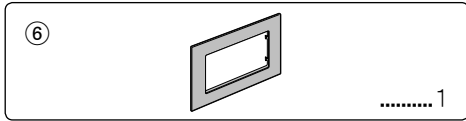
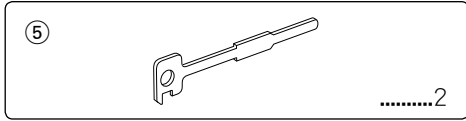
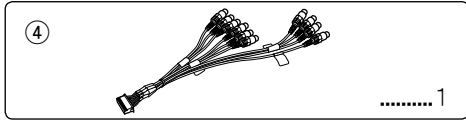
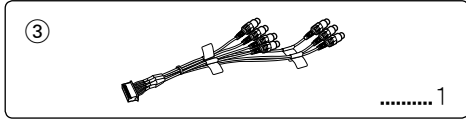
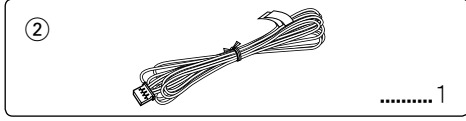
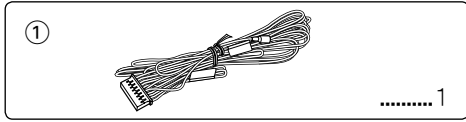

## 安装过程

1. 为了防止短路，请从点火开关上拔下钥匙，并断开⊖电池。
2. 正确连接各设备的输入和输出电线。
3. 连接线束的扬声器电线。
4. 按照以下顺序连接线束：接地线，电池线，点火线。
5. 将线束连接器连接到设备。
6. 将设备安装到车上。
7. 重新连接⊖电池。
8. 按下复位按钮。

### ▲警告

- 如果将点火线(红色)和电池线(黄色)连接到轿车底盘(地线)，可能会导致短路并起火。请始终将这些电线连接到接有保险丝盒的电源。
- 不得从点火导线(红色)和蓄电池导线(黄色)上拆下保险丝。电源必须通过保险丝与导线连接。



- 安装和接线此产品，需要一定的技巧和经验。出于安全原因的考虑，请将安装和接线工作留给专业人员来处理。
- 确保将设备接地到12V DC电源的负极。
- 不要将设备安装在直接日光照射或者太热或太湿的地点。此外，还要避免将设备安装在有太多灰尘或可能有水滴飞溅的地点。
- 不要使用您自己的螺丝。一定要使用我们提供的螺丝。如果使用错误的螺丝，则可能会损伤该设备。
- 如果电源无法接通(显示"PROTECT")，则扬声器电线可能短路或与汽车底盘接触，保护功能启动。因此，应当检查扬声器电线。
- 如果您的轿车点火开关不具有 ACC 位置，则请连接点火线到可由点火开关控制打开或关闭的电源。如果将点火线连接到恒定电压的电源，如电池电线，则电池将损坏。
- 如果控制台有盖子，则安装设备时，需确保设备打开和关闭时面板不会碰到盖子。
- 如果保险丝熔断，首先确保电线不会触碰而导致短路，然后用相同额度的保险丝替换。
- 用聚氯乙烯绝缘带或其它类似材料绝缘未连接的电缆。为了避免短路，请勿移除未连接电线末端的或端子的罩帽。
- 请将扬声器正确连接到其相应的端子。如果将⊖电线或接地线共同接到轿车的任何金属部分，则可能损坏设备。
- 当只有两个扬声器连接到系统，则请将连接器同时连接到两个前置输出端子或两个后置输出端子(请勿混接前置和后置端子)。例如，如果连接左扬声器⊕连接器到一个前置输出端子，则请勿将⊖连接器连接到后置输出端子。
- 在安装设备之后，请检查刹车灯、信号灯、雨刷等是否正常工作。
- 以30°或更小的安装角安装设备。
- 设备具有一个冷却风扇(第15页)以降低内部温度。安装设备时，请勿阻塞设备的冷却风扇。阻塞这些开口将会妨碍内部温度降低，从而导致故障。

- 在向汽车安装本机时，请不要用力按压面板表面。否则可能导致划伤、损坏或发生故障。
- 如果有金属物体靠近Bluetooth天线，接收可能发生中断。



Bluetooth 天线装置

**⚠️** 如果将点火线(红色)和电池线(黄色)连接到轿车底盘(地线),可能会导致短路并起火。请始终将这些电线连接到接有保险丝盒的电源。

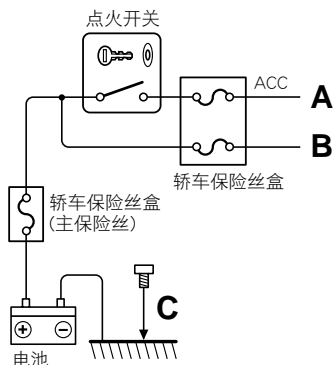

A ← 点火线(红色)

B ← 电池线(黄色)

C ← 地线(黑色)⊖(到轿车底盘)

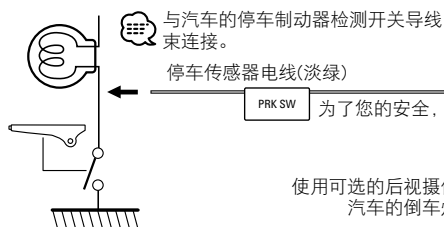
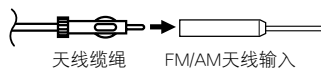

为了您的安全, 请确保连接停车传感器。

使用可选的后视摄像机时, 请与倒车传感器电线(紫色/白色)汽车的倒车灯线束连接。

方向盘遥控控制输入(淡蓝色/黄色)

至遥控

**💬** 使用方向盘遥控控制功能时, 需要使用兼容本轿车的专用遥控适配器(不随机提供)。如果不使用本端子, 请不要取下保护帽。

调光器控制电线(橙色/白色)

至车光控制开关

当电话铃响或通话期间连接到接地的终端。

静音电线(褐色)

**💬** 要连接建伍导航系统, 请查阅导航手册。

根据您所使用的天线, 将其连接到电动天线的控制终端, 或连接到膜式天线高频前级放大器的电源终端。

电动天线控制电线(蓝色)

当使用可选电源放大器时, 请连接到其电源控制终端。

电源控制电线(蓝色/白色)

至具备外部放大器控制功能放大器的"EXT.AMP.CONT"端子。

外部放大器控制电线(粉色/黑色)

**💬** 如果不进行连接, 请勿使电缆伸出接头。

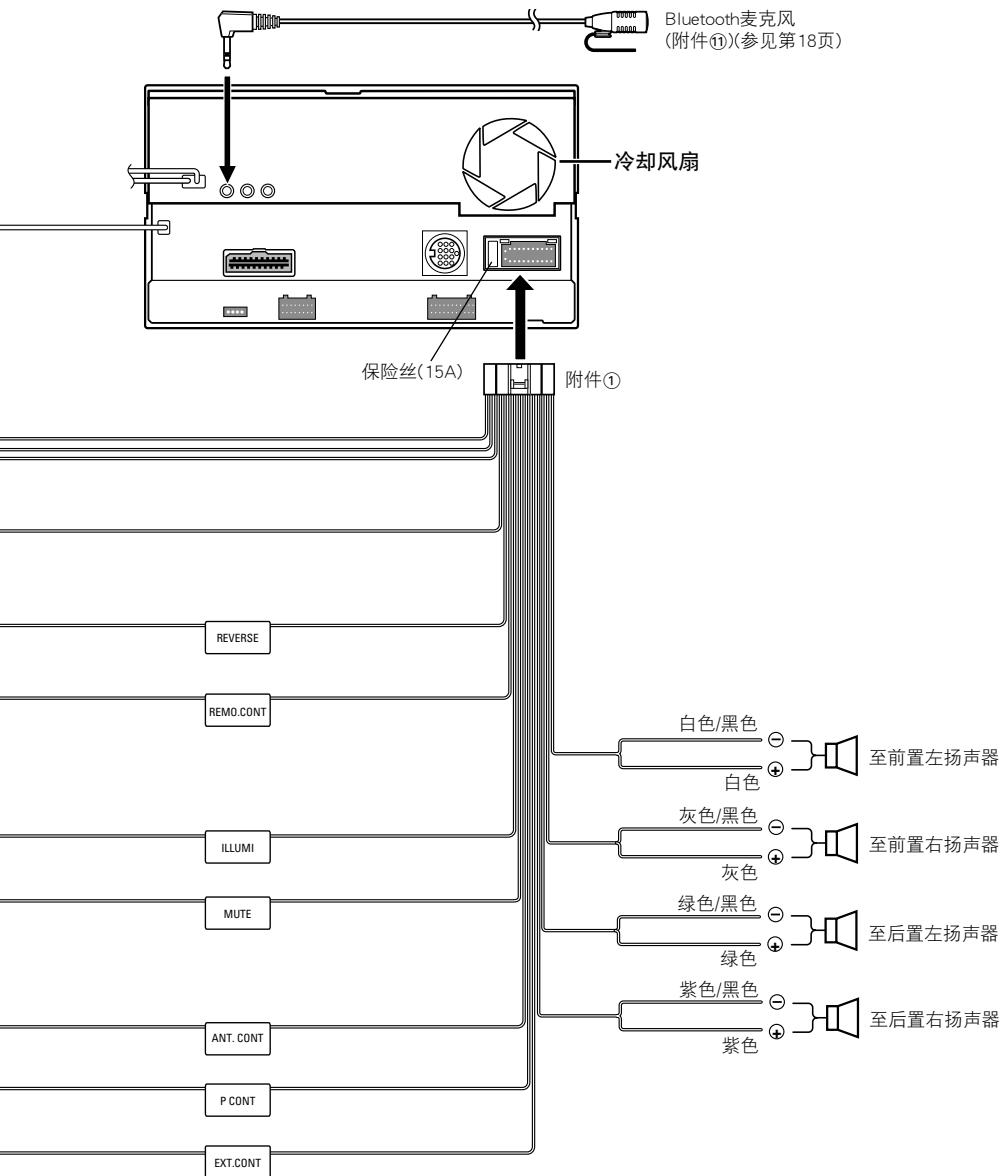

# 系统连接

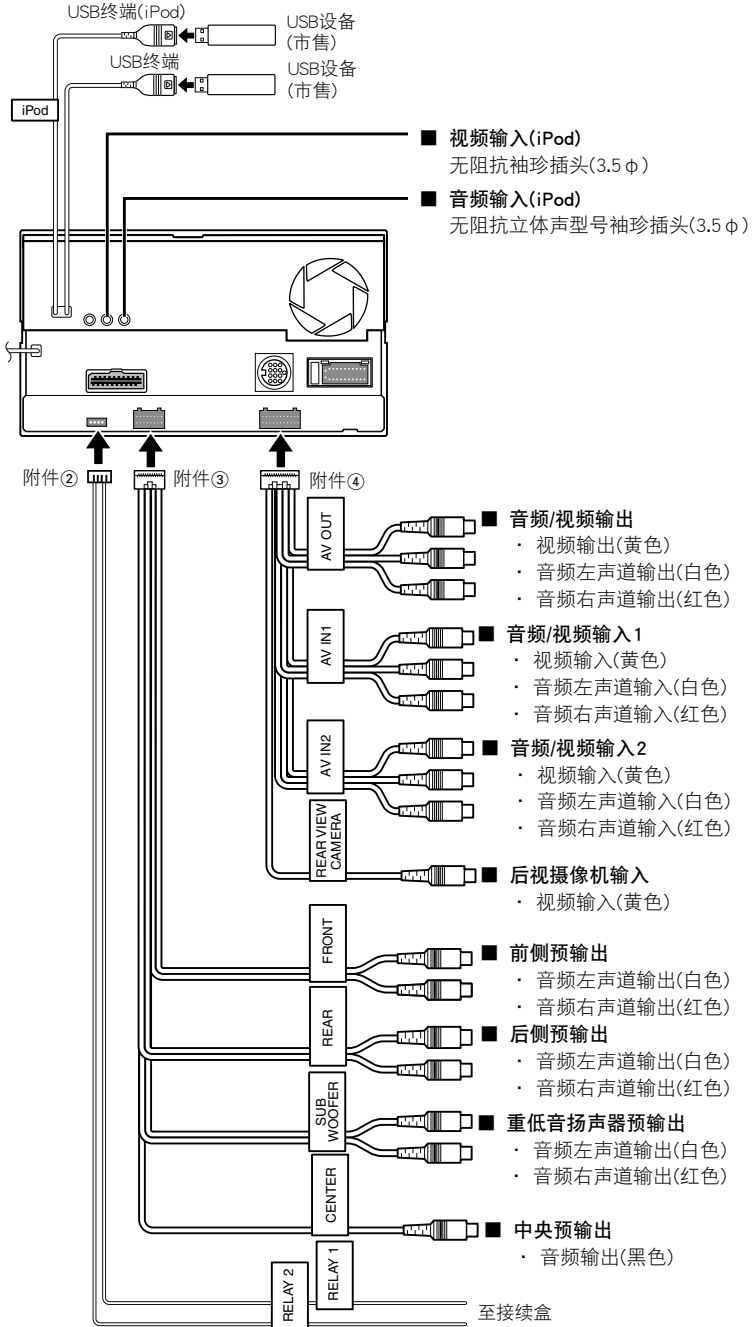



# 可选附件连接

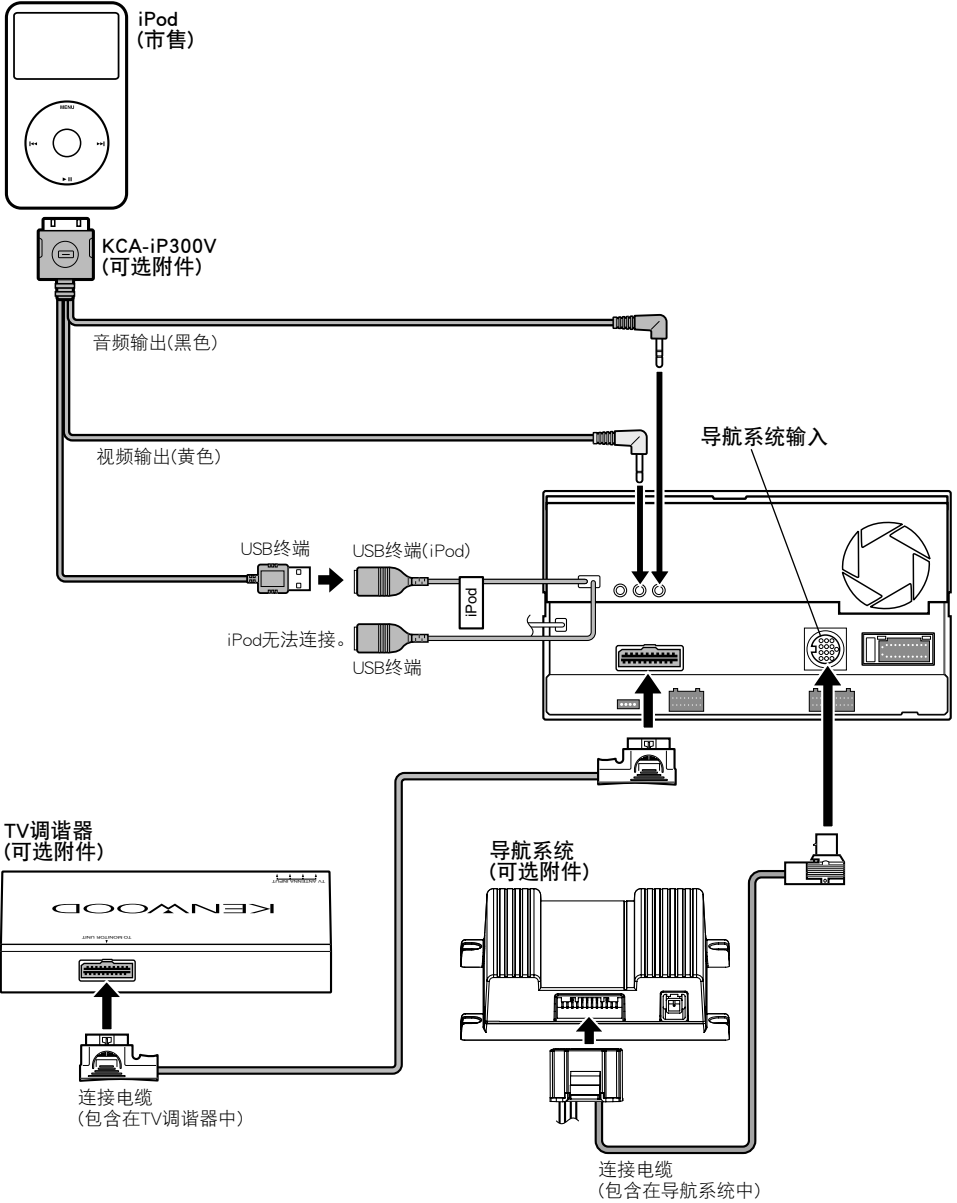

## 安装麦克风装置

1. 检查安装麦克风(附件⑪)的位置。
2. 擦干净安装表面的油污和灰尘等。
3. 安装麦克风。
4. 连接麦克风导线至免提盒，使用胶带等在数个位置固定。

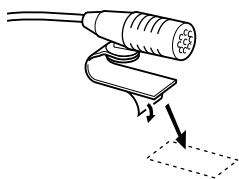
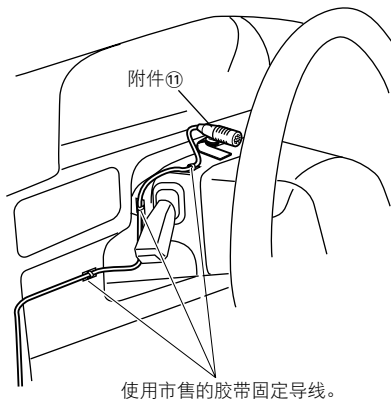

揭下双面胶带的保护纸，粘贴在上图所示位置。



调节麦克风的朝向朝向驾驶人员。

 将麦克风安装在尽可能远离手机的位置。

## 安装孔罩

### 对于常规汽车

1. 裁剪附件⑥以适应中央控制台开口的形状。
2. 将附件⑥安装到设备上。

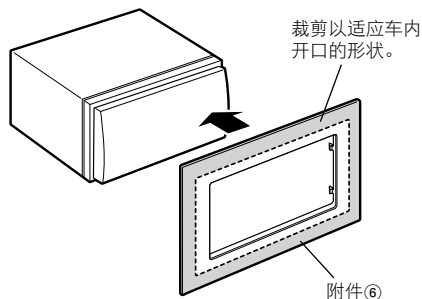

### 对于Volkswagen

1. 将附件⑩安装到设备上。

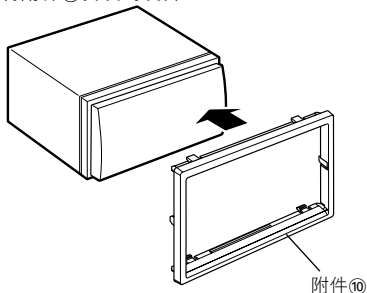

## 对于Toyota/Scion

1. 如图所示裁剪附件⑥。

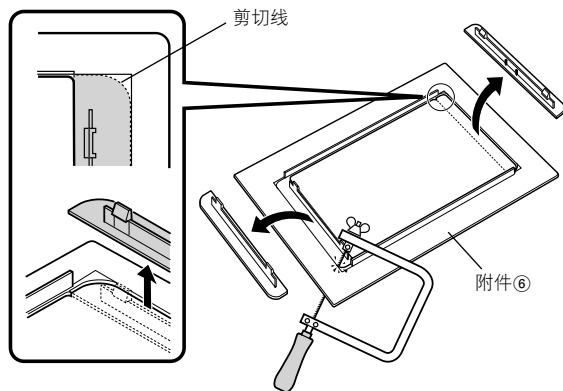

2. 如图所示，将双面胶带(附件⑦)沿切口折叠，将附件⑥的切下部分粘贴在外框中心。对于一个附件⑥的切下部分使用两片附件⑦。
3. 将附件⑥座孔粘合到设备上。

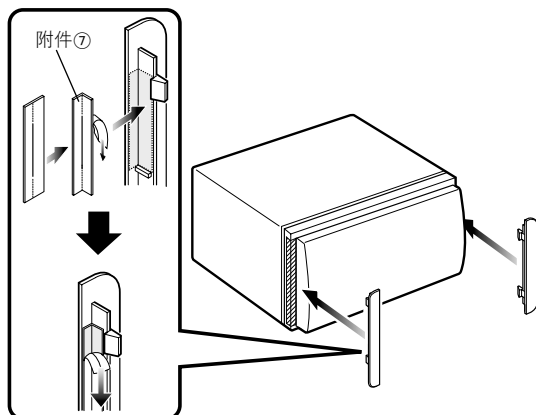

# 安装监视器/播放器设备

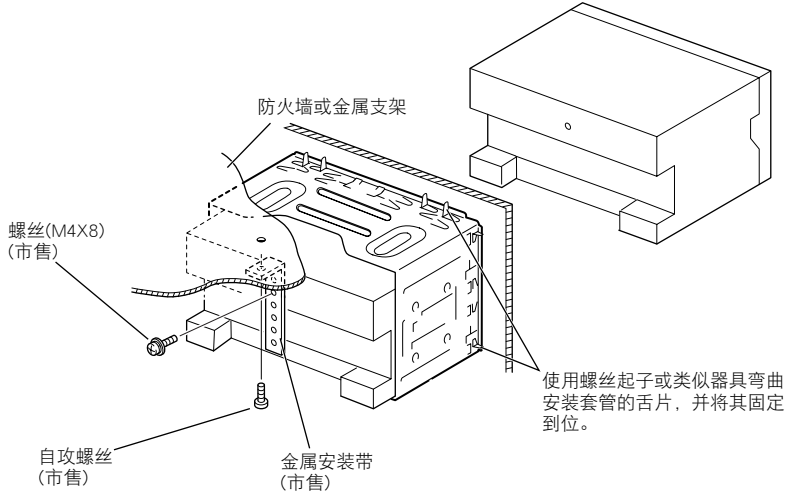

☞ 确保设备安装牢固。如果设备不稳固, 可能会出现故障  
(例如, 声音断续)。

## 使用支架在Toyota、Nissan或Mitsubishi轿车上安装

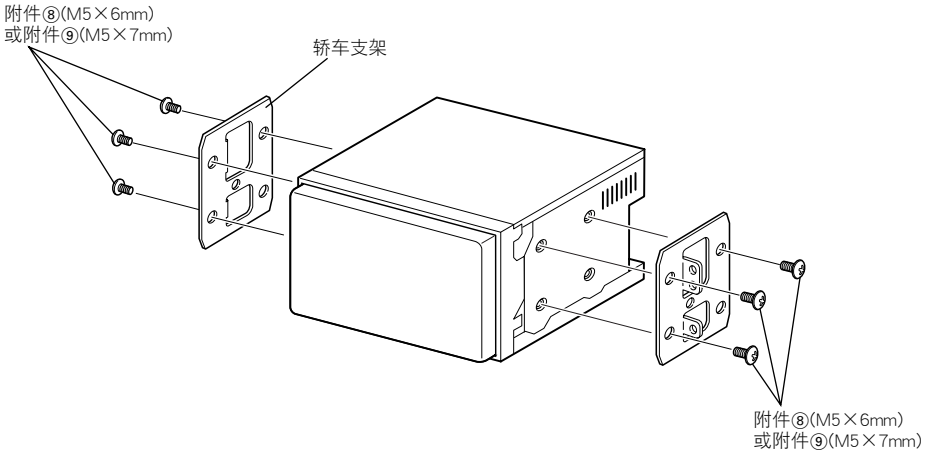

## 拆卸监视器/播放器设备

### 拆卸硬橡皮圈(孔罩)

1. 将搭钩销勾在拆卸工具⑤上，拆除底侧的两个锁扣。  
降低框架，并按图示向前拉。

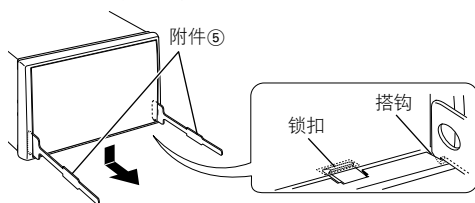

· 可用相同方法拆除顶部框架。

2. 当完成底侧拆卸后，拆下顶部两个位置。

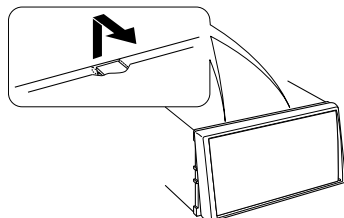

### 拆卸设备

1. 参照<拆卸硬橡皮圈>一节中的拆卸步骤来拆卸硬橡皮圈。
2. 拆除背板上的带有组成垫圈的六角螺丝(M4×8)。
3. 将两个拆卸工具⑤深深插入到两侧插槽内，如图所示。

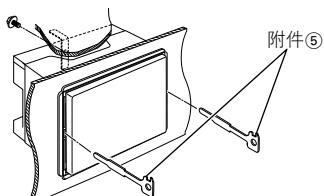

4. 朝底部下压拆卸工具，将设备拉出一半，同时向内侧按压。

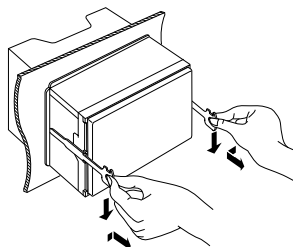

· 小心避免被拆卸工具上的搭钩销刮伤。

5. 用手将设备完全拉出，小心不要掉落。

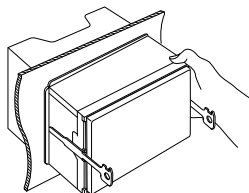

# 액세서리

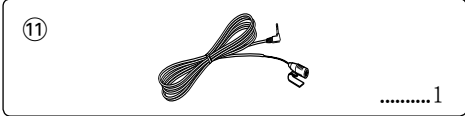
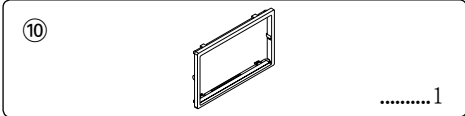
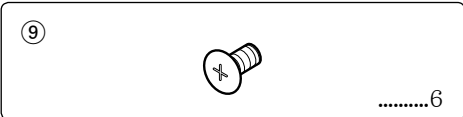
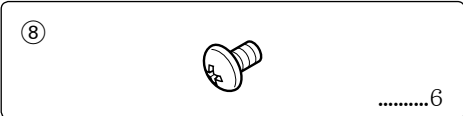
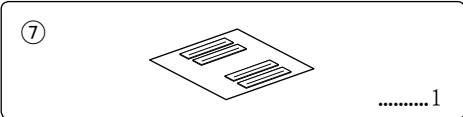
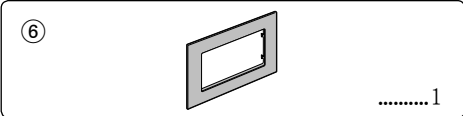
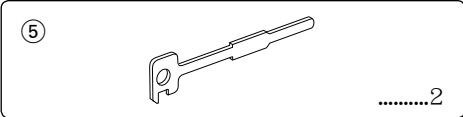
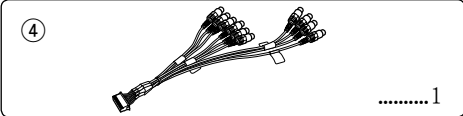
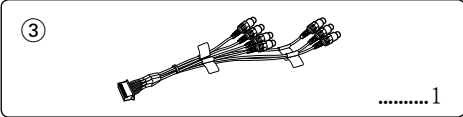
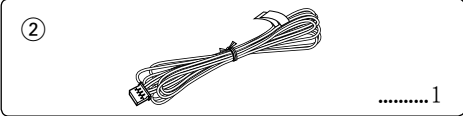
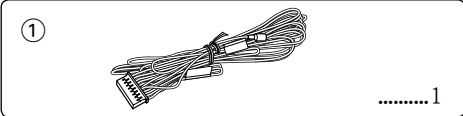

# 설치 절차

1. 누전을 방지하기 위해 시동 장치에서 키를 빼고  
⊖ 배터리를 분리하십시오.
2. 각 기기의 입력 및 출력 선을 올바르게 연결하십시오.
3. 배선 하네스의 스피커 선을 연결하십시오.
4. 배선 하네스 와이어를 다음 순서로 연결하십시오:  
접지, 배터리, 점화.
5. 기기의 배선 하네스 커넥터를 연결하십시오.
6. 차에 기기를 설치하십시오.
7. ⊖ 배터리를 다시 연결하십시오.
8. 리셋 버튼을 누르십시오.

## ▲경고

- 점화 선(빨강)과 배터리 선(노랑색)을 자동차 새시(바닥)에 연결하면 누전을 일으켜 화재가 발생할 수 있습니다. 이 선을 항상 퓨즈 단자를 통해 공급되는 전원 에 연결하십시오.
- 퓨즈를 점화 선(빨강)과 배터리 선(노랑)에서 자르지 마십시오. 전원 공급은 퓨즈를 통해 선으로 연결되어야 합니다.



- 이 제품을 설치하고 배선하려면 전문적인 기술과 경험이 필요합니다. 안전을 위해 설치 및 배선 작업을 전문 기술자에게 의뢰하십시오.
- 기기를 -12V DC 전원 공급 장치에 접지시켜야 합니다.
- 직사광선 또는 과도한 열이나 습도에 노출되는 곳에는 기기를 설치하지 마십시오. 또한 먼지가 많거나 물이 튀길 수 있는 곳에도 설치하지 마십시오.
- 사용자 자신의 나사를 사용하지 마십시오. 제공된 나사만을 사용하십시오. 잘못된 나사를 사용할 경우 기기가 손상될 수 있습니다.
- 전원이 켜지지 않으면("PROTECT"가 디스플레이됨), 스피커 단락이 있을 수 있거나 차량의 새시에 닿아서 보호 기능이 활성화될 수 있습니다. 그러므로, 스피커 선을 반드시 점검하십시오.
- 차량의 시동 장치에 ACC 위치가 없으면 시동 키로 켜고 끝 수 있도록 점화 선을 전원에 연결하십시오. 연속 전원을 공급하는 전원에 점화 선을 연결할 경우 배터리가 방전될 수도 있습니다.
- 콘솔에 뚜껑이 있는 경우 이 뚜껑을 열고 닫을 때 제품의 전면 플레이트에 손상이 가지 않도록 주의하여 설치하십시오.
- 퓨즈가 끊어진 경우에는 먼저 배선이 누전된 원인을 찾고 나서 동급 퓨즈로 교체하십시오.
- 연결되지 않은 선은 비닐 테이프나 이와 유사한 기타 물질로 절연시키십시오. 누전을 방지하기 위해 연결되지 않은 배선이나 터미널의 끝에 씌워져 있는 캡을 제거하지 마십시오.

- 스피커 선을 해당하는 터미널에 올바르게 연결하십시오.
- 선을 공용으로 사용하거나 차의 급속 부분에 닿게 되면 기기가 손상되거나 올바르게 작동하지 않을 수도 있습니다.
- 시스템에 두 개 스피커만 연결되어 있는 경우에는 커넥터를 두 개의 앞쪽 출력 터미널이나 두 뒤쪽 출력 터미널에 연결하십시오(앞쪽과 뒤쪽을 섞지 마십시오). 예를 들어, 좌측 스피커의 ⊕ 커넥터를 프론트 출력 터미널에 연결하는 경우 ⊖ 커넥터를 뒤쪽 출력 터미널에 연결하지 마십시오.
- 기기를 설치한 후에는 차량의 브레이크 램프, 방향등, 와이퍼 등이 올바르게 작동하는지 점검하십시오.
- 기기 설치 시 각도를 30° 이하로 설치하십시오.
- 이 기기에는 내부 온도를 감소시키기 위한 냉각 팬(25 페이지)이 있습니다. 이 기기를 이 기기의 냉각 팬이 막힌 곳에 장착하지 마십시오. 이 곳을 막으면 내부 온도 냉각을 막아 제대로 기능을 할 수 없습니다.
- 차량에 기기를 설치할 때 패널 표면을 세게 누르지 마십시오. 그렇지 않으면 흠집, 손상 또는 실재를 초래할 수 있습니다.
- Bluetooth 안테나 가까이에 금속 물체가 있으면 수신이 떨어질 수 있습니다.

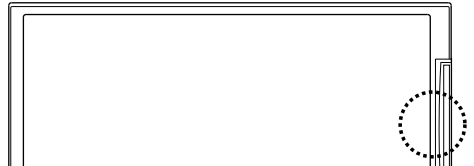

Bluetooth 안테나 기기

**!** 점화 선(빨강)과 배터리 선(노랑색)을 자동차 새시(접지)에 연결하면 누전을 일으켜 화재가 발생할 수 있습니다. 이 선을 항상 퓨즈 단자를 통해 공급되는 전원에 연결하십시오.

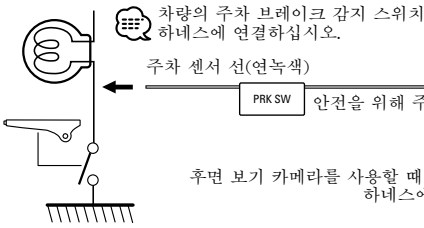
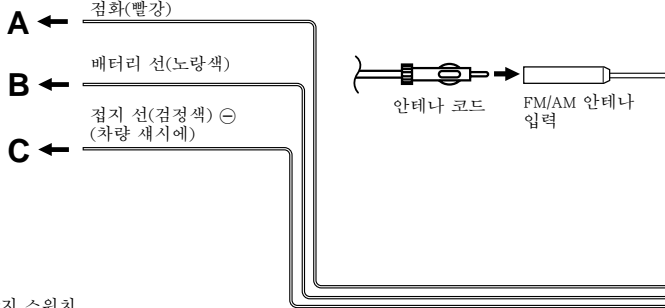
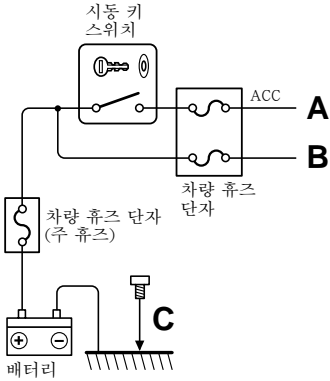

역 센서 선(자주색/흰색)

원격 조절에 리모콘 입력 조절 (얇은 청색/노랑)

핸들 리모콘 기능을 사용하기 위해, 전용 리모콘 어댑터 (공급되지 않음)를 필요한 차에 맞춰야 합니다. 단자를 사용하지 않을 때는, 캡을 그대로 두십시오.

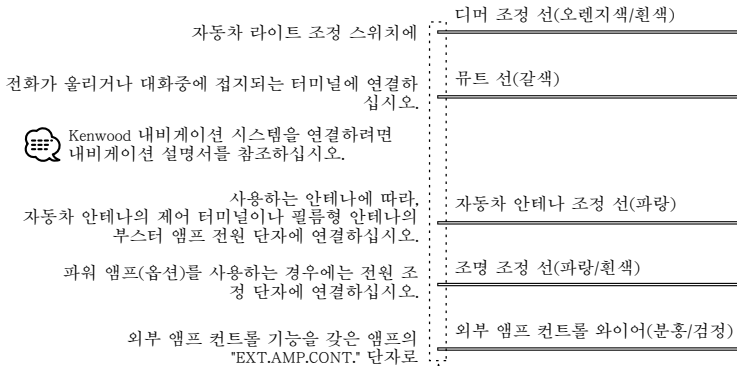

연결이 안되면 케이블을 탭에서 나오게 하지 마십시오.



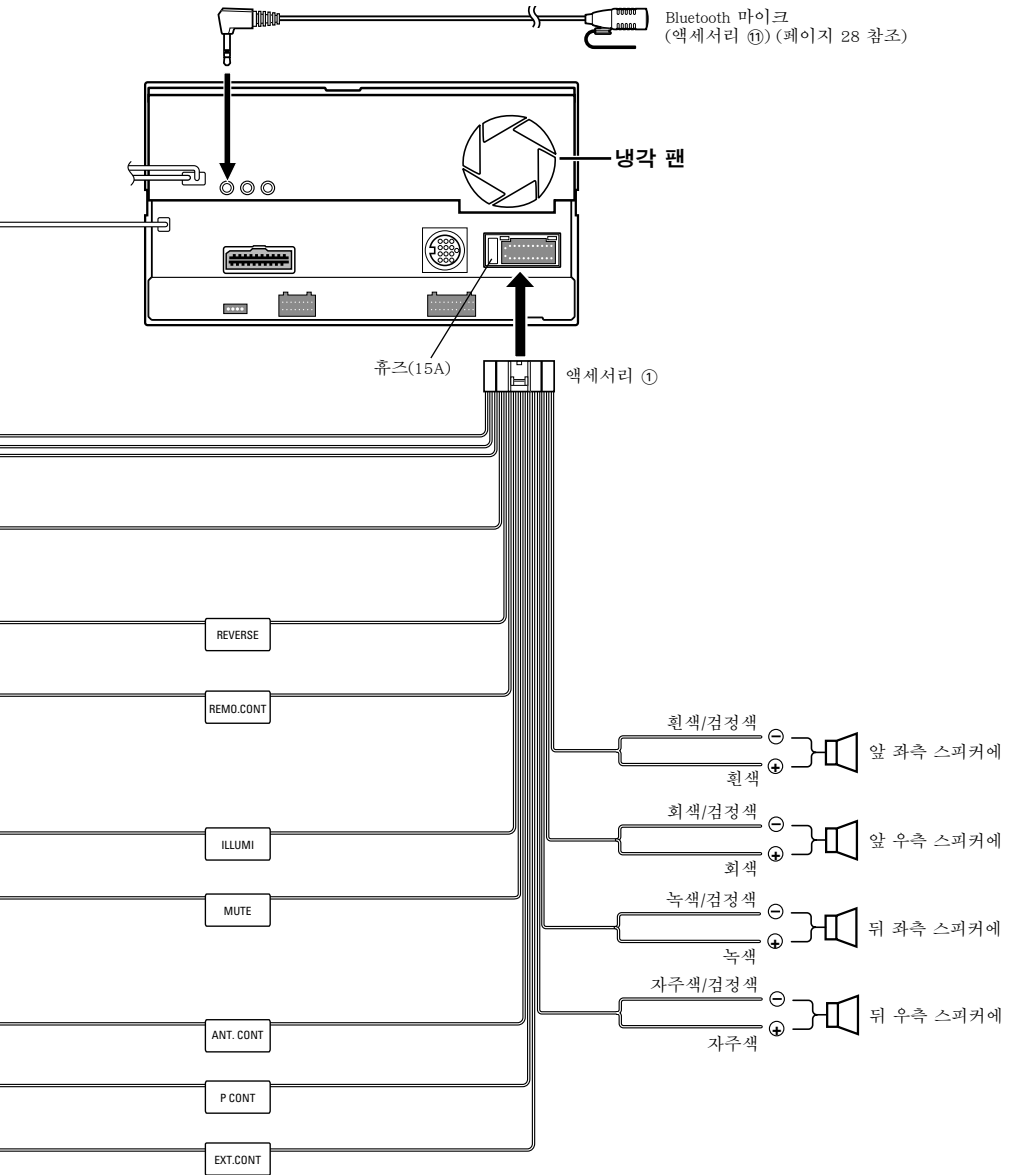

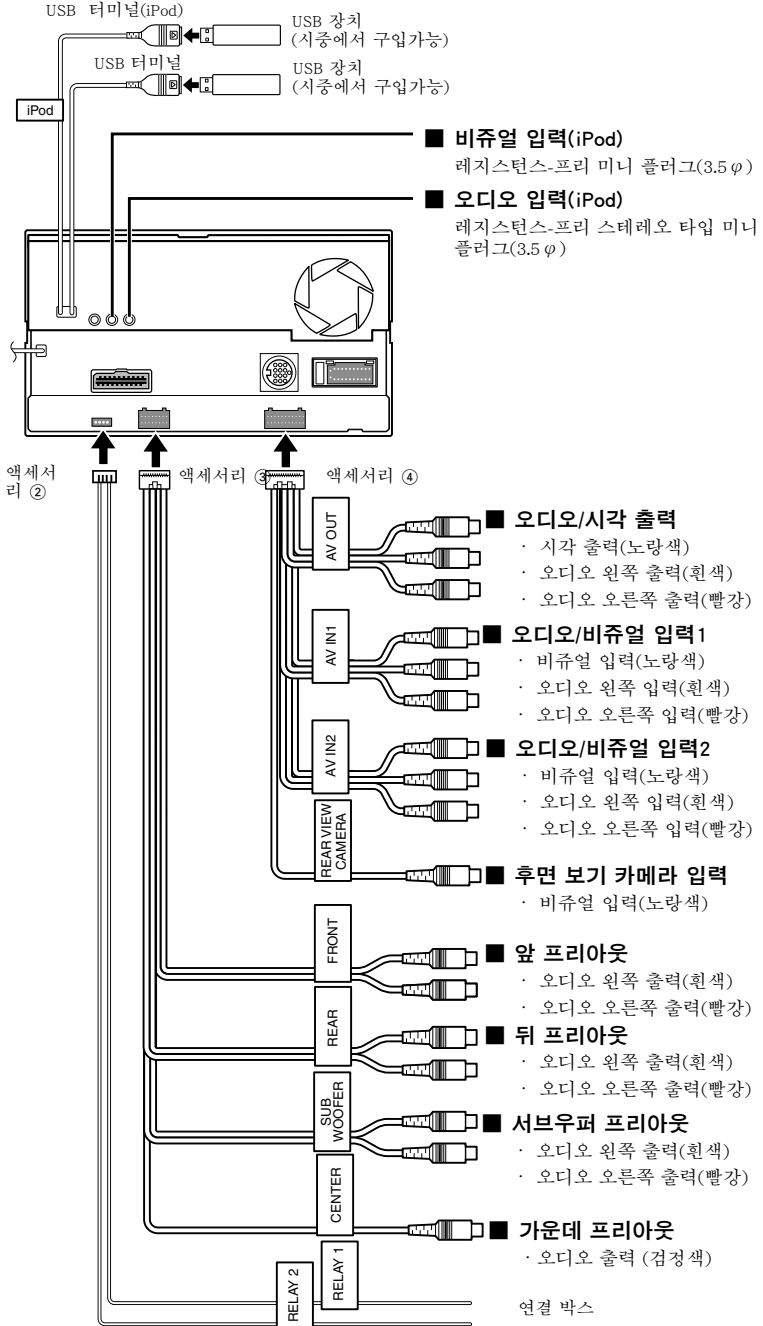

# 옵션 액세서리 연결

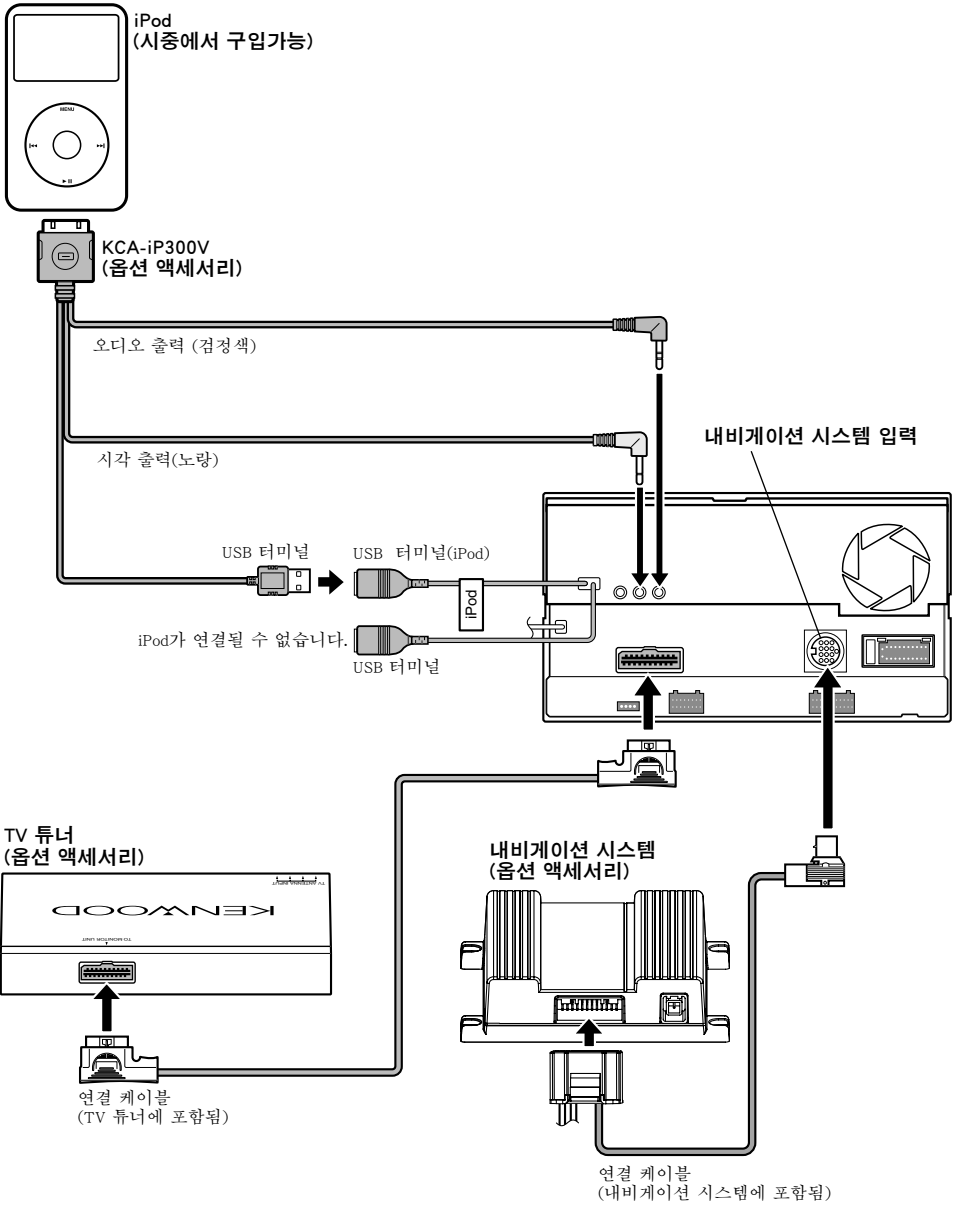

## 마이크 기기 설치

1. 마이크 설치 위치를 점검하십시오(액세서리 ⑪).
2. 설치 표면에 기름과 기타 오물을 제거하십시오.
3. 마이크를 설치하십시오.
4. 테이프 또는 비슷한 것으로 마이크 케이블을 여러 위치에 고정된 핸드프리 케이블까지 연결하십시오.

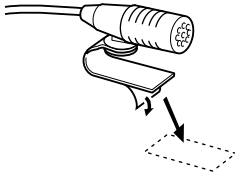
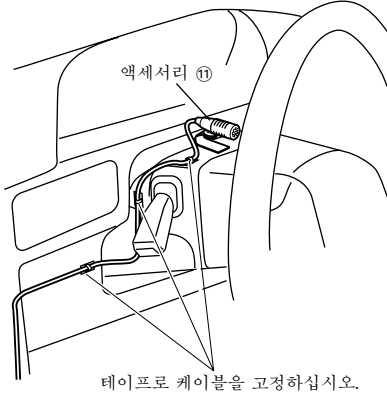

양면 테이프의 박리 코팅된 종이를 벗기고 위에 보여진 위치에 고정하십시오.



마이크 방향을 운전자 쪽으로 맞추십시오.

 마이크를 휴대폰에서 가능한 한 멀리 설치하십시오.

## 보호판 설치

### 일반 모터용

1. 콘솔 가운데의 구멍의 형태에 맞춰 액세서리 ⑥를 잘라내십시오.
2. 액세서리 ⑥를 기기에 부착하십시오.

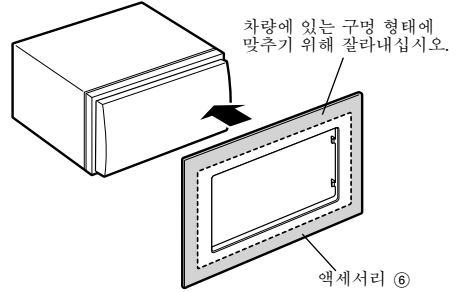

### Volkswagen용

1. 액세서리 ⑩를 기기에 부착하십시오.

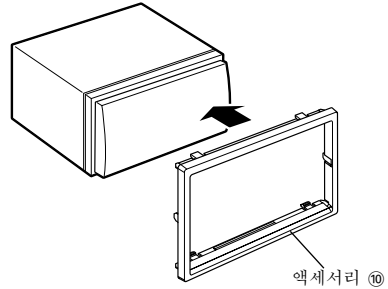

## Toyota/Scion용

1. 액세서리 ⑥를 그림대로 잘라내십시오.

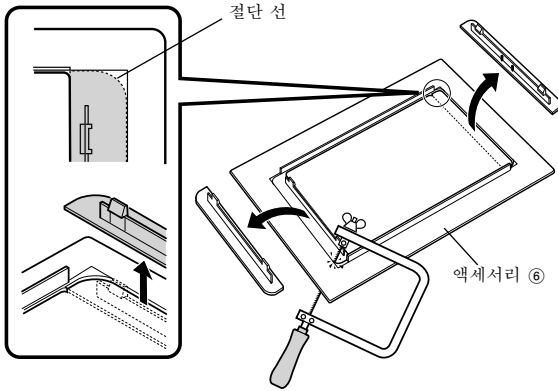

2. 그림처럼 틈새를 따라 양면 접착물(액세서리 ⑦)을 접어서, 중앙 리브에 대고 액세서리 ⑥를 컷아웃에 부착하십시오. 액세서리 ⑦를 컷아웃을 위한, 1개의 액세서리 ⑥를 사용하십시오.
3. 액세서리 ⑥를 컷아웃을 기기에 부착하십시오.

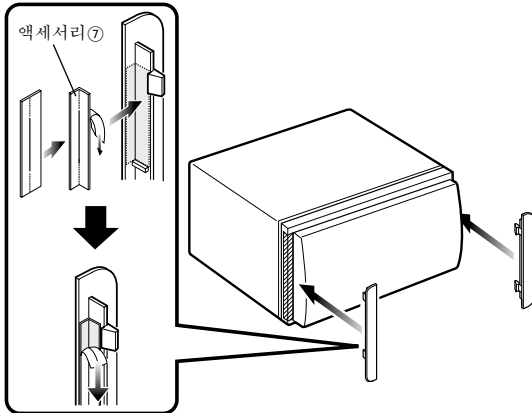

# 모니터/플레이어 기기 설치

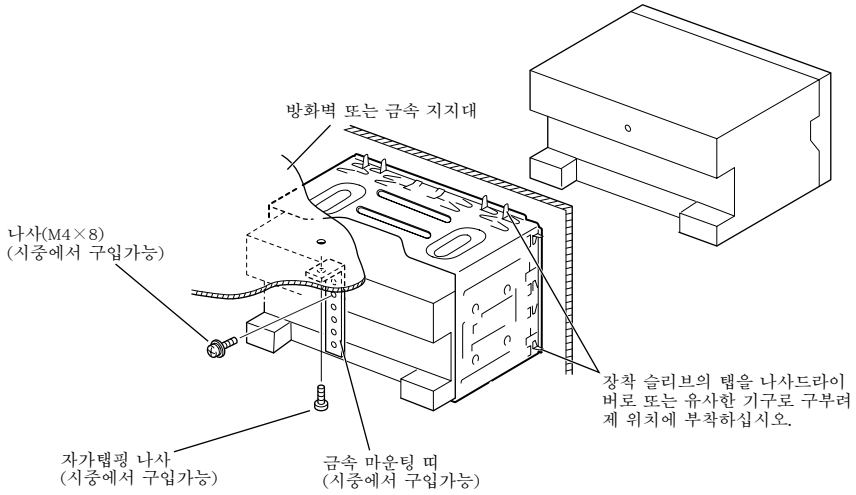

 기기가 제자리에 안전하게 장착되는지 확인하십시오. 이 기기가 불안정하면 제대로 작동하지 않을 수 있습니다(예, 사운드가 건너뛴 수 있습니다).

## 브래킷을 이용한 Toyota, Nissan 또는 Mitsubishi에서의 설치

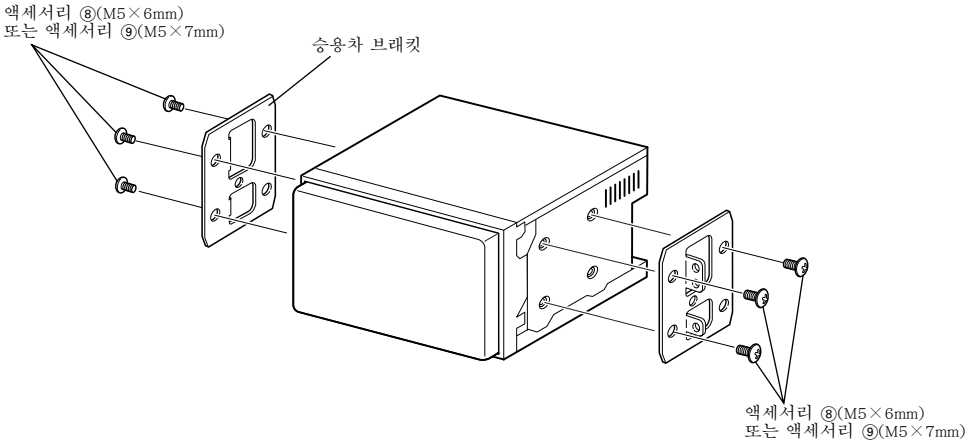

# 모니터/플레이어 기기 제거하기

## 단단한 고무 프레임 제거 (보호판)

1. 제거 도구 ⑤에 캐치 핀을 확대하여 낮은 쪽의 두 개의 락을 제거하십시오.  
프레임을 낮추고 그림에 나타난 것처럼 앞으로 당기십시오.

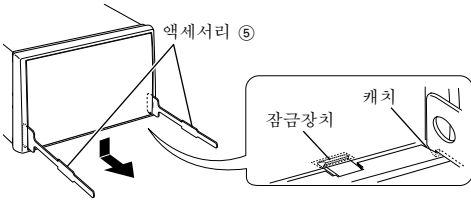

· 같은 방법으로 프레임을 상부에서 제거할 수 있습니다.

2. 아래쪽에서 제거하였으면 위쪽 두 곳에서 제거하십시오.

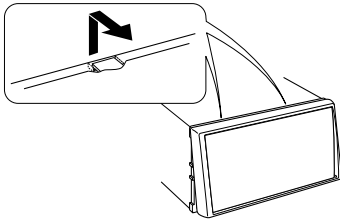

## 기기 제거

1. <단단한 고무 프레임 제거> 부분의 제거 과정을 참조하여 단단한 고무프레임을 제거하십시오.
2. 뒷 패널에서 인테그럴 와셔와 함께 6각 머리 나사를(M4 × 8) 제거하십시오.
3. 보여진 대로, 두 개의 제거 도구 ⑥를 각 면의 슬롯에 깊이 삽입하십시오.

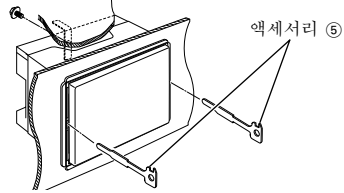

4. 제거용 공구를 아래쪽으로 낮추고, 내부를 앞쪽으로 밀면서 기기를 빼십시오.

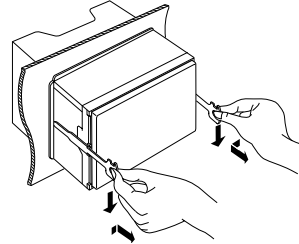

· 제거용 공구의 캐치 핀에 부상을 입지 않도록 주의하십시오.

5. 떨어뜨리지 않도록 주의하면서 기기를 손으로 끝까지 당기십시오.

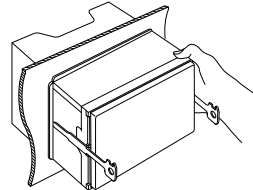

---

**KENWOOD**