

JVC



VIDEO CD PLAYER

影音光碟機

XL-MV558GD

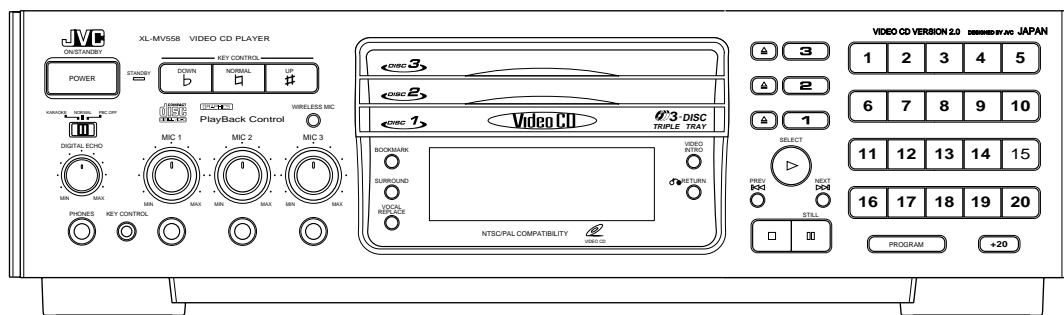
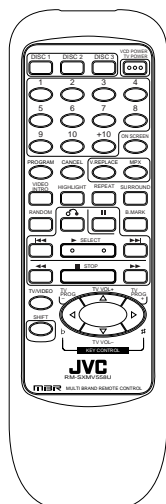

PlayBack
Control

Video CD

COMPACT
disc
DIGITAL VIDEO

COMPACT
disc
DIGITAL AUDIO
GRAPHICS

COMPACT
disc
DIGITAL AUDIO

INSTRUCTIONS

使用說明書

For Customer Use:

Enter below the Model No. and Serial No. which are located either on the rear, bottom or side of the cabinet. Retain this information for the future reference.

Model No.

Serial No.

LET0089-001A
[UF]

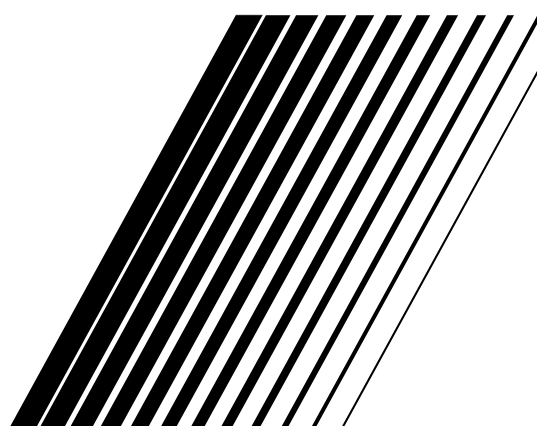

Warnings

警告，注意及其他須知事項

IMPORTANT for the U.K.

DO NOT cut off the plug for this equipment. If the plug fitted is not suitable for the power points in your home or the cable is too short to reach a power point, then obtain an appropriate safety-approved extension lead or consult your dealer.

BE SURE to replace the fuse only with an identical approved type, as originally fitted.

If nonetheless the plug is cut off, remove the fuse and dispose of the plug immediately, to avoid a possible shock hazard by inadvertent connection to the power supply.

If this product is not supplied fitted with a plug then follow the instructions given below:

IMPORTANT.

DO NOT make any connection to the terminal which is marked with the letter E or by a safety ground symbol or coloured green or green/yellow.

The wires in the lead on this product are coloured in accordance with the following codes:

Blue : Neutral
Brown : Live

As these colours may not correspond with the coloured markings identifying the terminals in your plug proceed as follows:

The wire which is coloured blue must be connected to the terminal which is marked with the letter N or coloured black.

The wire which is coloured brown must be connected to the terminal which is marked with the letter L or coloured red.

IF IN DOUBT - CONSULT A COMPETENT ELECTRICIAN.

Caution — POWER switch!

Disconnect the plug to shut the power off completely. The POWER switch in any position does not disconnect the unit from the power source. The power can be remote controlled.

CAUTION

To reduce the risk of electrical shock, fire, etc.:

1. Do not remove screws, covers or any parts.
2. Do not expose this appliance to rain or moisture.

注意

為了減低觸電，火災等危險：

1. 請勿擅自卸下螺絲釘，蓋子或機殼。
2. 切勿讓本機受雨淋或置潮濕環境中。

IMPORTANT FOR LASER PRODUCTS

雷射產品的重要說明

LABELS

標籤內容說明

① CLASSIFICATION LABEL PLACED ON REAR ENCLOSURE

① 分類標籤，貼在機殼背後。

② WARNING LABEL PLACED INSIDE THE UNIT

② 警告標籤，貼於機內。

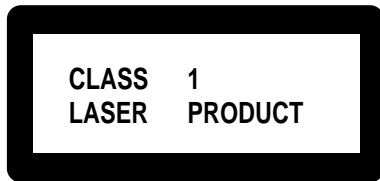

DANGER: Invisible laser radiation when open and interlock failed or defeated. AVOID DIRECT EXPOSURE TO BEAM. (e)

WARNING: Osynlig laserstrålning när denna del är öppnad och spärren är urkopplad. Betrakta ej strålen. (s)

ADVARSEL: Usynlig laserstråling ved åbning, når sikkerhedsafbrydere er ude af funktion. Undgå udsættelse for stråling (d)

VARO: Avattaessa ja suojalukitus ohitettaessa olet alltiina näkymättömälle lasersäteilylle. Älä katso säteeseen. (f)

1. CLASS 1 LASER PRODUCT

2. **DANGER:** Invisible laser radiation when open and interlock failed or defeated. Avoid direct exposure to beam.

3. **CAUTION:** Do not open the top cover. There are no user serviceable parts inside the Unit; leave all servicing to qualified service personnel.

1. 一級雷射產品

2. 危險：當內部鎖定裝置失效或者損壞後，打開蓋板可能會產生不可見的雷射輻射。應避免受到光束直接照射。

3. 注意：請勿打開頂蓋板。本機內部沒有用戶可自行維修的部件；所有維修工作應由有資格的人員完成。

GENERAL INFORMATION

Care and handling of compact discs

How to handle CDs

When handling a compact disc, do not touch the surface of the disc (reflective silver side — the side without the label).

Since compact discs are made of plastic, they are easily damaged. If a disc gets dirty, dusty, scratched or warped, the sound will not be picked up correctly and, in addition, such a disc may cause the CD player to malfunction.

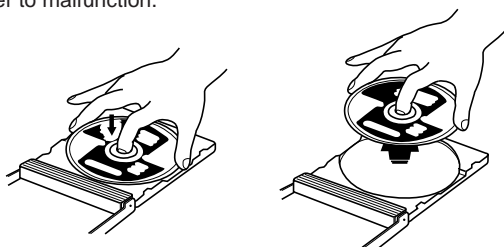

Even on label side

Do not damage the label side, stick paper to or use any adhesive on its surface.

Storage

Make sure that discs are kept in their cases. If discs are piled one on top of another without their protective cases, they can be damaged. Do not put discs in a location where they may be exposed to direct sunlight, or in a place where the humidity or temperature is high. Avoid leaving discs in your car!

Maintenance of discs

If there are fingerprints or other dirt adhering to a disc, wipe it with a soft dry cloth, moving from the center outwards.

If a disc is difficult to clean, wipe with a cloth moistened with water. Never use record cleaners, petrol, alcohol or any anti-static agents.

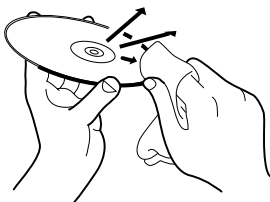

CAUTION

Sometimes during play noise or images may be garbled. This is sometimes due to the disc. (It may not be up to industry standards.) These symptoms are caused by the discs, not by the malfunction of the Player.

Which compact discs can be used?

Many types of compact discs are sold for a variety of uses. The Video CD Player can play the following compact discs:

- **Video CD**
for audio and video (moving picture) reproduction, including multiplex sound.
- **Video CD with Playback Control function**
featuring menu-type operation and super-fine still pictures for audio and video (moving picture) reproduction, including multiplex sound.
- **CD Graphics (CD-G)**
for audio and video (still picture) reproduction, including multiplex sound.
- **Digital Audio CD, including single discs**
for audio reproduction.



PlayBack Control



CDs you can't play back

Do not play back CD-ROMs, DVDs, or CD-i on this equipment. Doing so may generate a noise which can damage your speakers.

Using the remote control

The remote control is ready to use when its batteries are installed properly.

To use it, point its infrared light-emitting window toward the display window of the player and press a button. The operating range of the remote control is up to about seven meters in front of the player and within about 30 degrees to each side — with nothing between the remote control and the player interrupting the beam path.

If pressing a button on the remote control does not produce any response, check to make sure it is pointed correctly and try again. If it still does not function, check the batteries.

BEFORE USING FOR THE FIRST TIME

Basic Connections

The Video CD Player must be connected directly to a television set or an amplifier that is connected to a television or monitor. The television set or the amplifier must have audio input jacks for right and left channels and a video input jack.

Select a level, dry location free of dust and vibration, and having a temperature maintained between 5 and 35°C (41 and 95°F).

Connecting player to a TV or amplifier using the Audio Video cord

First connect the Audio Video cord — before connecting the AC power cord.

Firmly insert the yellow pin plug of the Audio Video cord in the yellow VIDEO OUT jack on the rear panel of the player; the red pin plug in the red AUDIO OUT (RIGHT) jack; and the white pin plug in the white AUDIO OUT (LEFT) jack. (The RIGHT and LEFT output jacks are for the right and left audio channels.)

Then make sure that the television, amplifier or receiver is turned off, disconnect the AC power cord and firmly insert the pin plugs at the other end of the Audio Video cord into the matching video and audio INPUT jacks.

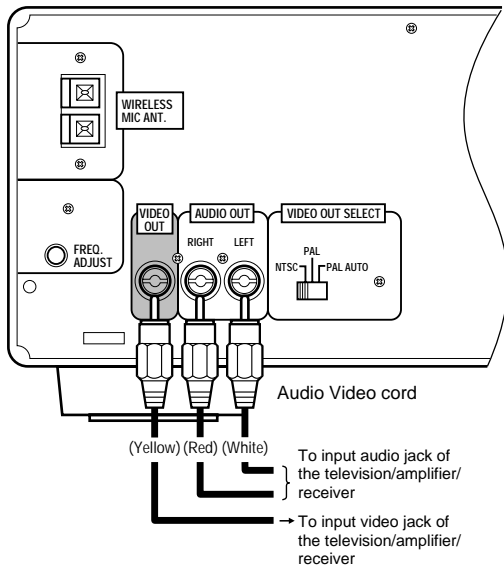

Video out select

Set the VIDEO OUT SELECT switch on the rear panel to NTSC, PAL, or PAL AUTO mode according to your television system.

NTSC for NTSC exclusive TV

PAL for PAL exclusive TV

PAL AUTO for Multisystem TV

PAL AUTO is the mode to detect the format of the disc (NTSC/PAL) automatically and play the image on screen the right way.

Notes

- When you play a NTSC disc in PAL AUTO mode on a PAL exclusive TV, the image may get distorted. (If the signal doesn't synchronize.) In this case, reselect the mode to "PAL".
- Select the mode before you play the disc. If you change the mode during play, images may get distorted. In this situation stop the player and reset the mode.
- When you play a NTSC disc in PAL AUTO mode on a Multi system TV, the image may blink for a moment. This symptom is caused by the Player detecting the format of the disc and not caused by a malfunction of the Player.

Connecting the power cord

IMPORTANT

Check the setting of the LINE VOLTS switch on the rear panel of the player. Change the setting if the switch is not set for the main voltage supplied to your home.

With the LINE VOLTAGE switch correctly set and the audio-video connectors connected, insert the smaller plug of the power cord firmly into the AC POWER CORD socket on the rear panel of the player.

When the power cord is connected, the STANDBY indicator on the left-hand side of the player's front panel comes on. [See "Overview of controls" for a description of the controls on the player.]

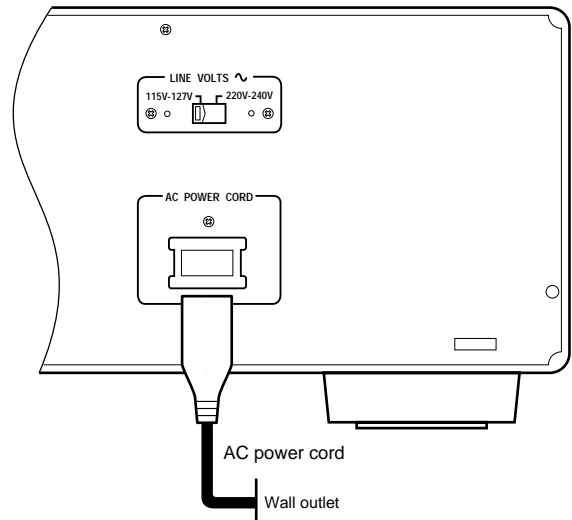

Line voltage alteration

What is your power main voltage? Is it between 115 and 127V, or 220 and 240V? If the LINE VOLTS switch on the rear panel of the player is not set to your power main voltage, disconnect the power cord, if it is already connected, and change the switch setting accordingly.

Installing batteries

Putting batteries in the remote control

The battery compartment is located on the back of the remote control.

1. Insert a finger in the recess under the battery compartment cover, and pull off the cover.

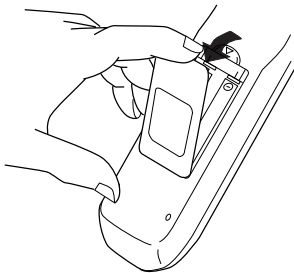

2. Place the two accessory R6P(SUM-3)AA(15F) batteries in the remote control according to the polarity markings (“+” and “-”) inside the compartment and on the batteries.

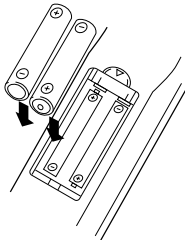

3. Insert the two tabs of the cover in their respective slots, and snap the cover in place.

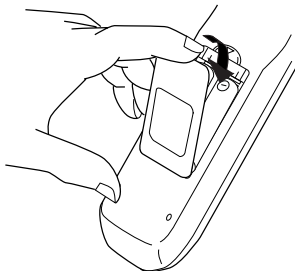

The batteries last about one year with normal use. If function of the remote control become erratic, replace the batteries.

Precautions for the safe use of batteries

Observe the following precautions for the safe use of batteries. Their life will be shortened, they may burst or their contents may leak if they are used improperly:

- Remove batteries from the remote control if it is not going to be used for a long period of time.
- Remove dead batteries and dispose of them properly.
- Never leave dead batteries lying around, take them apart, mix them with other refuse, or throw them into an incinerator.
- Never touch liquid that has leaked out of a battery.
- Do not mix new and old batteries, or batteries of different types, when replacing them.

Putting batteries in the microphone

1. Unscrew and remove the battery compartment cap as illustrated.

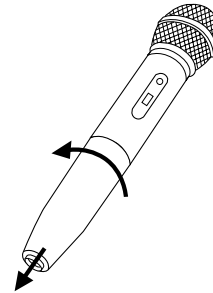

2. Insert 2 “R6P (SUM-3)/AA(15F)”-size batteries (provided), oriented correctly.

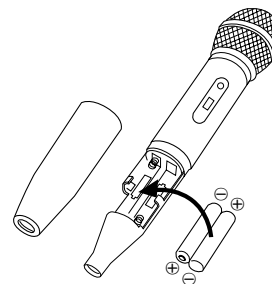

3. Screw the cap back on as illustrated.

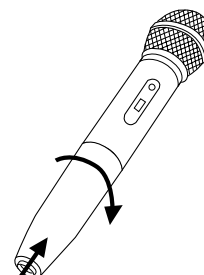

OVERVIEW OF CONTROLS

Here the basic function of controls on the front panel of the Player and the remote control are explained. The function of some controls may be restricted in actual use depending on the on-going operations. The remote

control has fourteen (14) unique function buttons in addition to those on the player.

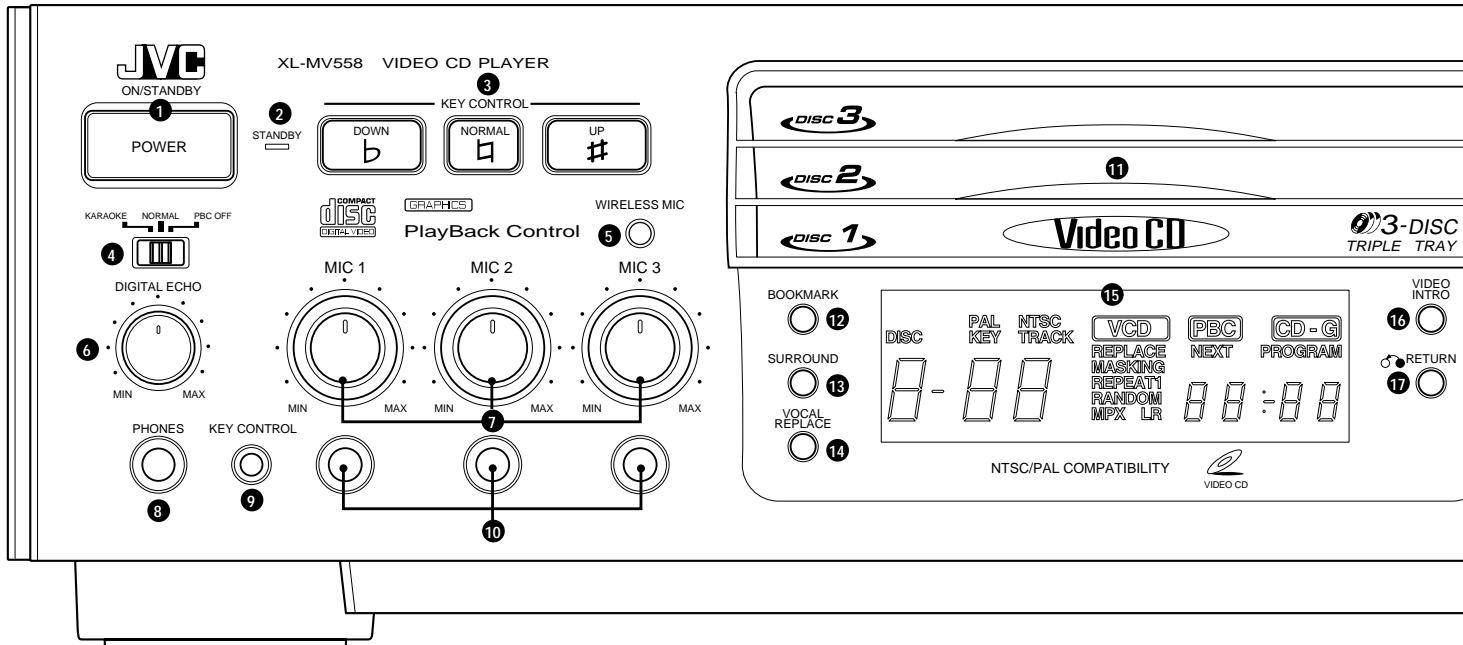

Left front panel of the Player

(controls marked (R) have equivalents on the remote control)

- 1 POWER button (R)**
turns the power on and off.
- 2 STANDBY indicator (Red)**
lights when the power cord is connected and the power is turned off. The STANDBY indicator is not lit when the player is turned on.
- 3 KEY CONTROL button (R)**
Transposes the music key.
DOWN ♭ button : used to flatten by a half tone.
NORMAL ♯ button : returns to original key tone.
UP # button : used to sharpen by a half tone.
- 4 MODE switch**
Switches the KARAOKE/NORMAL/PBC OFF mode.
KARAOKE mode : one track playing mode.
NORMAL mode : continuous plural tracks playing mode. Required also for the Playback Control (PBC) function.
PBC OFF mode : inhibits the Playback Control (PBC) function of the video CD.
- 5 WIRELESS MIC button with indicator**
activates/deactivates the wireless microphone. When the WIRELESS MIC button is pressed, the indicator is lit as follows.
green: tuning accomplished.
red: not successful. For tuning, see page 16.
- 6 DIGITAL ECHO knob**
adjusts the degree of the echo effect for the microphone (1 through 3) and the wireless microphone voice.
- 7 MIC1 to MIC3 knobs**
adjusts volume of the microphone corresponding to MIC number. Wireless microphone volume adjustment is performed using the MIC 3 knob.
- 8 PHONE jack**
used for connecting stereo headphones. The volume is set to a predetermined level and is not adjustable.
- 9 KEY CONTROL jack**
used for connecting a microphone with key control function.
- 10 MIC jacks (1 through 3)**
used for connecting microphones (1 through 3). The jacks correspond to MIC 1 to 3 volume knobs located above.

Center front panel of the Player

- 11 DISC1 to DISC3 trays**
used to load discs. To insert/remove one or up to three (3) discs, press the ▲ OPEN/CLOSE button located at the right of the tray.
- 12 BOOKMARK button (R)**
Place a "bookmark" at a video segment you want to find later for almost instant play. (See page 14.)
- 13 SURROUND button (R)**
Changes the surround mode. (See page 14.)
- 14 VOCAL REPLACE button**
activates the vocal replace function, which inserts your voice in place of the vocals on the disc.
- 15 Display window**
shows information about the status of operation.
- 16 VIDEO INTRO button (R)**
applies to video CDs only. The introductory five (5) seconds of tracks on a video CD are displayed on the television screen in order to present the contents of the video CD. (See page 13.)
- 17 RETURN button (R)**
Utilized for operation with the PBC function. This button is used to return to a menu screen during play. (See page 18.)

Right front panel of the Player

- 18 ▲ (OPEN/CLOSE) buttons (Disc number 1 to 3)**
Used to open and close disc trays 1 to 3 respectively. When, after opening the DISC1 tray, another ▲ (OPEN/CLOSE) button is pressed, the DISC1 tray is first closed, then the other DISC tray selected is opened.
- 19 DISC1 through DISC3 buttons with indicators (Green) (R)**
plays the disc of the number indicated on the button. As soon as the disc begins playing, the indicator blinks.
- 20 Number keys (1 to 20) (R:1 to 10)**
used to specify a track number for playing, changing, or programming. To operate numbers above twenty (20), press the +20 button once. The number keys (1 to 20) are then assigned 21 to 40 numbers instead of 1 to 20. The maximum key number assignment is 99. In PBC function operation, the number keys are additionally utilized for the selection of menu items. See page 18 "Operation of Playback Control function".

The controls with identical names on the Player as on the remote control have the same function and are used in the same manner.

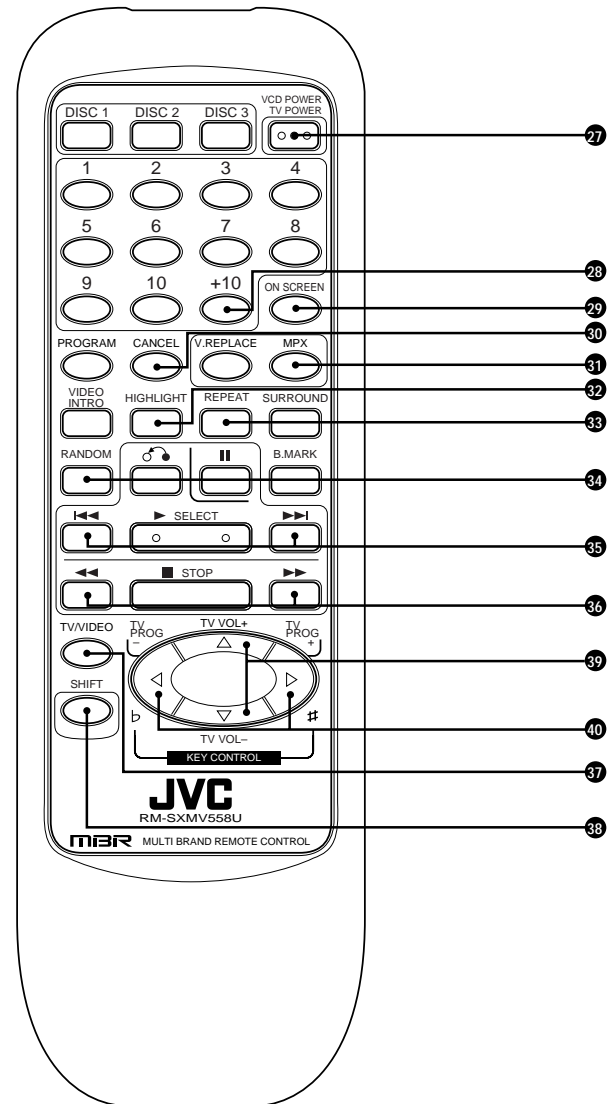
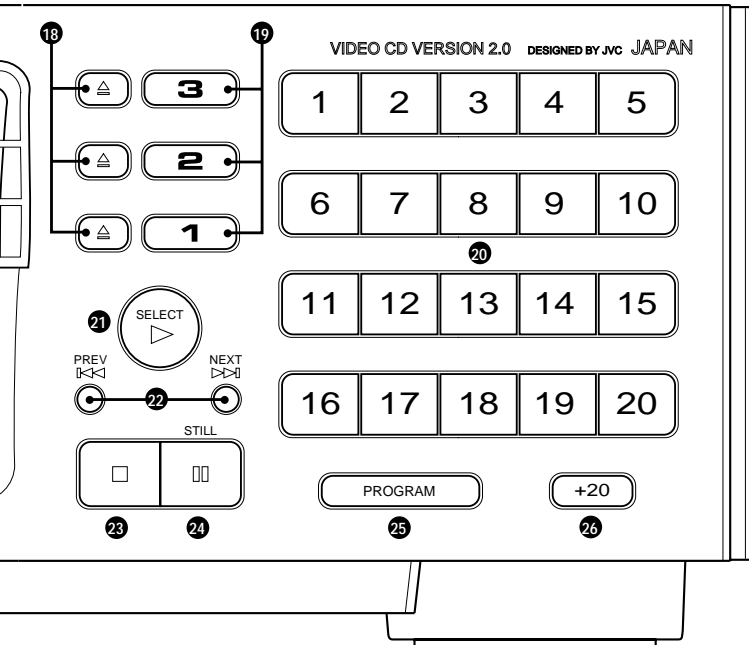

- 21 ▶ SELECT (PLAY) button (R)**
Starts to play the disc with/without the Playback Control function.
- 22 ◀◀ / ▶▶ PREV / NEXT buttons**
During operation with the Playback Control function invokes previous or next screen.
During operation without the Playback Control function skips forward or backward quickly from current track being played. When pressed and held down, play fast backward/forward. See page 8.
- 23 ■ (STOP) button (R)**
Stops play.
- 24 || STILL (PAUSE) button (R)**
temporarily suspends playing. Video motion freezes and audio reproduction stops. Pressing the button repeatedly advances the picture frame-by-frame. (Video CD only)
- 25 PROGRAM button (R)**
Any desired sequence of tracks can be programmed with the number keys and the +20 button. (on the remote control please use +10) The program button is not available while the Playback Control function is activated.
- 26 +20 button**
used to shift the numbers assigned to the number keys to 21 or higher (maximum 99).

On the remote control unit

- 27 VCD POWER/TV POWER button**
Turns the player on and off.
When pressed after you hold down the SHIFT button, turns the TV on or off.
- 28 +10 button**
used to shift the numbers assigned to the number keys to 11 or higher (maximum 99).
- 29 ON SCREEN button**
Controls whether or not control and operation status are displayed on the television screen or monitor.
- 30 CANCEL button**
Cancels the latest track you have programmed or cancels the bookmark. Also used to cancel a bookmark.
- 31 MPX button**
Activates the multiplex function, which switches to NORMAL (stereo), L-ch monaural and R-ch monaural.
- 32 HIGHLIGHT button**
Applies to a video CD to see highlights of a track. Displays the first (5) seconds of each of nine (9) equal-time segments of the track.
- 33 REPEAT button**
Repeats a track or inserted discs from 1 to 3.
- 34 RANDOM button**
Changes the disc track program to a random sequence from disc 1 through 3 respectively.
- 35 ◀◀ / ▶▶ AUTO SEARCH button**
Skips forward or backward from a current track. Holding down the button causes it to skip tracks much faster.
- 36 ◀◀ / ▶▶ MANUAL SEARCH button**
Shifts the playing location backward and forward quickly. Holding down the button causes it to go much faster.
- 37 TV/VIDEO button**
Used to preset the remote control unit, to control some functions on your TV set. (See page 9.)
- 38 SHIFT button**
Used together with other keys for various functions. (See page 9, "Using the remote control.")
- 39 TV VOL + / TV VOL - keys**
Turns the TV volume up or down.
- 40 TV PROG - / TV PROG + /KEY CONTROL**
Changes the television channel.
When pressed after you hold down the SHIFT button, changes the key in which the music plays. (See page 9.)

BASIC OPERATIONS

Now you can play a variety of video CDs!!

Overview of the three modes

This Player has three (3) modes called KARAOKE, NORMAL, and PBC OFF mode. These are selected by the MODE switch. This enables various ways of playing a video CD.

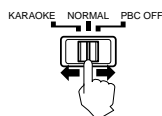

KARAOKE mode: One track playing mode. Whenever one track has completed play, the Player stops.

NORMAL mode: Continuous plural tracks playing mode. The Player plays tracks continuously in the order they appear on the disc.

PBC OFF mode: This mode is identical to the NORMAL mode, except that the PBC function is inhibited.

To set the mode, switch the MODE switch on the left side of the front panel.

Triple disc tray usage

Up to three (3) discs can be loaded in the Player. You may insert a disc into any of the disc trays 1 through 3 whichever you prefer.

If you want to play only a specified disc, press the corresponding disc 1, 2 or, 3 button located to the right of the ▲ (OPEN/CLOSE) button.

When three discs are in inserted, basic order of playing is as following.

- Pressing DISC 1: DISC 1 → DISC 2 → DISC 3 → STOP
- Pressing DISC 2: DISC 2 → DISC 3 → DISC 1 → STOP
- Pressing DISC 3: DISC 3 → DISC 1 → DISC 2 → STOP

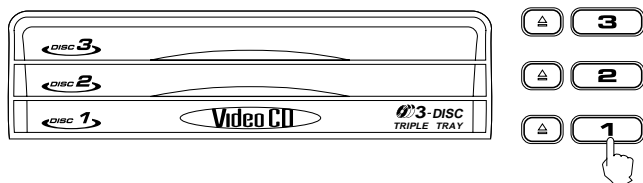

Description of the display window

The display window indicates many aspects of control and operation status.

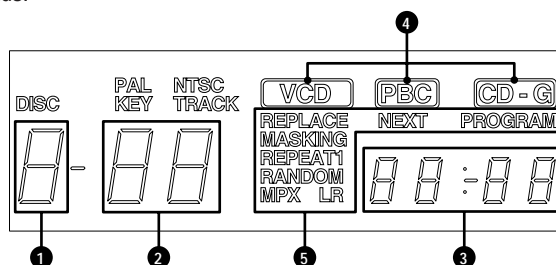

- 1 Shows the disc number being played.
- 2 Shows mainly the total number of tracks and the track number being played.
- 3 Shows the surround mode status and the cumulative time (minutes and seconds) of the track and afterward, total time of the disc is displayed.
- 4 The combination of VCD, PBC, and CD-G indicators lit shows the type of disc being played.
- 5 Each indicator in this area lights when the corresponding function is activated.

Preparation for playing

Turn on the television set, amplifier or receiver to which the Player is connected, and then select the proper channel and mode to operate the Player, and set the sound volume to a reasonable level.

Press the POWER button on the front panel or remote control.

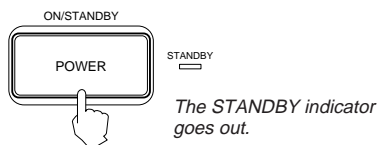

The display window shows the initial information as shown below.

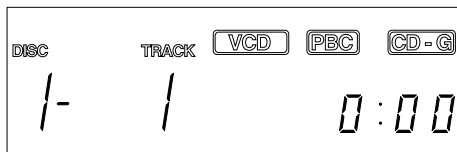

Easy start up

Without pressing the POWER button you can start up the Player by pressing ► SELECT button or disc buttons.

Inserting/removing the disc(s)

Press the ▲ (OPEN/CLOSE) button (1 through 3) to open the disc tray. Then place the disc in the round recess of the tray with label side up. To close the tray, press the ▲ (OPEN/CLOSE) button again.

If you press the ▲ (OPEN/CLOSE) button of the playing disc, the Player stops and then opens the tray.

If you press the ▲ (OPEN/CLOSE) button of a disc that is not being played, you can change discs without stopping play.

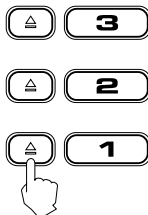

Notes

- When loading a disc in the disc tray, be sure to position the disc inside the recess. Otherwise, the disc will be damaged when the disc tray is closed, and the disc cannot be removed from the unit.

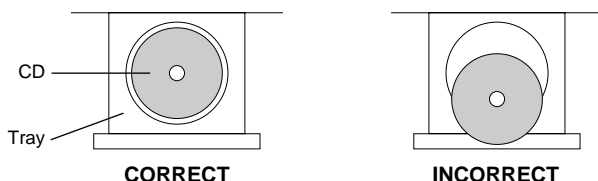

Starting to play disc(s)

Press the ► SELECT (PLAY) button. The Player starts to play from the disc indicated in the Display window.

Press one of the DISC 1 through 3 buttons and the Player plays the disc you pressed, from the 1st track. For individual track selection, use the number keys or the ◀◀/▶▶ PREV/NEXT buttons.

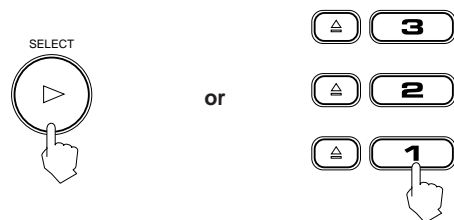

When you start play, the Display window shows disc number and the track number being played.

During play, the indicator on the DISC button blinks.

If the PBC function is activated, the display window shows "Pb" until you play a track, and the television screen shows the initial menu, DISC number, and "PBC". See page 18, "Operation of Playback Control function".

When you press ► SELECT button during play, the disc will restart from the beginning of the track except when the PBC function is activated.

Using number keys

Press the number keys to select numbers.

On the Player 1 to 20 and +20 key

Example: For number 5, press 5. For number 15, press 15. For number 32, press +20 button, then 12. For number 42, press +20 twice, then 2.

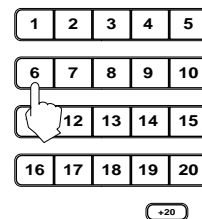

On the remote control 1 to 10 and +10 key

Example: For number 5, press 5. For number 15, press +10, then 5. For number 20, press +10, then 10. For number 32, press +10 three times, then 2.

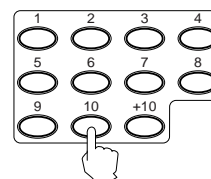

Note

When you press number keys, track will start playing without pressing ► SELECT button.

Stopping play

Press the ■ (STOP) button to stop play at any time.

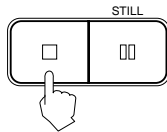

Pausing play

Press the ■ STILL (PAUSE) button to temporarily suspend play.

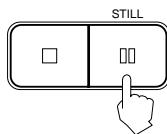

Notes

- When the ■ STILL (PAUSE) button is pressed once, "PAUSE" appears on the television screen, the video motion freezes and the sound is turned off. The still picture advances frame-by-frame each time the ■ STILL (PAUSE) button is pressed. This frame-by-frame function is effective only for video CDs.
- To release the pause, press the SELECT or blinking DISC 1 through 3 button.
- During "PAUSE" the time counter on the display will blink.

Auto search/Manual search

On the Player, during play, pressing the ◀◀ button once causes the Player to replay the current track from the beginning. Pressing the ◀◀ button twice causes the Player to play the previous track. Pressing the ▶▶ button once causes the Player to skip to the next track. Holding down the ◀◀/▶▶ buttons causes the disc to fast reverse or forward.



On the remote control, holding down the ◀◀/▶▶ buttons causes the disc to fast reverse or forward.

Continuing to hold down the buttons causes it to search much faster.

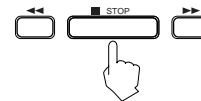

(Remote control)

On the remote control, during play, pressing the ◀◀ button once causes the Player to replay the current track from the beginning. Pressing the ◀◀ button twice causes the Player to play the previous track. Pressing the ▶▶ button once causes the Player to skip to the next track.

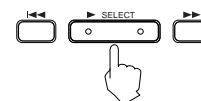

(Remote control)

Using stereo headphones

Connecting stereo headphones

Connect stereo headphones to the PHONES jack at the lower-left of the front panel. The volume level is fixed and cannot be adjusted.

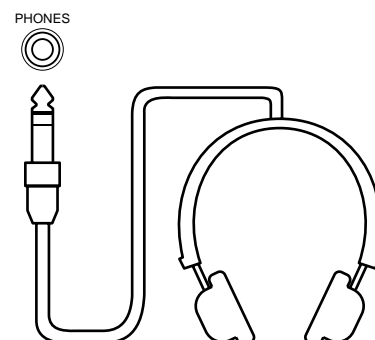

Using the remote control

Presetting the remote control to operate your own TV

You can use the Player's remote control unit to control some functions on your TV set (e.g., turning the TV on and off, adjusting volume, or selecting channels). First, though, you must preset the remote control to make it compatible with your TV.

Operation

1. Check the Preset Code Table (page 10) to determine the two-digit brand code number for your TV.
2. While holding down the TV/VIDEO button on the remote control, press the Number keys to insert the two-digit brand code number. (For example, if the code number is "28", press Number key 2, then 8. If the first digit is a "0", press 10. Thus, if the code number is "09", press Number key 10, then 9. If the code number is "10", press Number key 1, then 10. If it is "20", press Number key 2, then 10.)

Notes

- Before the remote control unit leaves the factory, the brand code number is set as No. 01 (JVC).
- Depending on your television set's age and other factors, brand code numbers may be different from those shown in the table. In such a case, try out other codes until you find one that corresponds to your television.

3. While still holding down the TV/VIDEO button, press the STOP button on the remote control.



4. If the code number is correct, the TV will turn off. Repeat the procedure from the beginning if you weren't successful the first time.

Using the SHIFT button on the remote control unit

You can control other functions with the remote control, simply by holding down the SHIFT button while pressing another button. Some of these functions are useful for Karaoke and Video CD playing, others for controlling the TV.



■ SHIFT button functions for Karaoke and Video CD playing

SHIFT + TV PROG - → KEY CONTROL (b)

SHIFT + TV PROG + → KEY CONTROL (#)

■ SHIFT button functions to control the TV

SHIFT + VCD POWER → Turns the TV on and off

SHIFT + 1 → TV Channel 1

SHIFT + 2 → TV Channel 2

SHIFT + 3 → TV Channel 3

SHIFT + 4 → TV Channel 4

SHIFT + 5 → TV Channel 5

SHIFT + 6 → TV Channel 6

SHIFT + 7 → TV Channel 7

SHIFT + 8 → TV Channel 8

SHIFT + 9 → TV Channel 9

SHIFT + 10 → TV Channel 0*

Note

- The asterisk * indicates that these operations do not work for some manufacturers' television sets.

Preset code table

No.	Television Manufacturer
01	JVC
02	PANASONIC
03	SONY
04	SHARP
05	TOSHIBA/BEIJING/CHANGHONG
06	MITSUBISHI/CHANGHONG
07	HITACHI
08	SANYO
09	FUNAI
10	AIWA
11	DAEWOO
12	SAMSUNG
13	LG (GOLDSTAR)
14	THOMSON
15	FERGUSON
16	PHILIPS/TCL/CHANGHONG
17	GRUNDIG
18	ITT
19	MIVER
20	FINLUX
21	NOKIA
22	NEC
23	JINXING/PEONY1
24	PEONY2
25	PEONY3/CHANGHONG
26	KONKA
27	PEIJIN/NOBLEX
28	TCL

VARIOUS UNIQUE FUNCTIONS

Various functions can enhance your enjoyment

Display of operations status

Preparation

This function is controlled by the remote control.

Operation

Press the **ON SCREEN** button on the remote control. By pressing the **ON SCREEN** button, the following information may be easily and quickly displayed or erased on the television screen.

Time, Disc mode, Echo effect, Key control, Program, Repeat, Random, Multiplexing, Vocal replace, Vocal masking, Bookmark, etc.

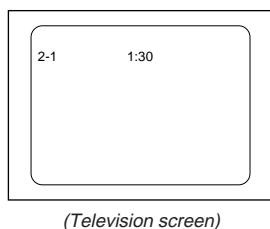
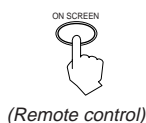

Programming the track sequence you want

Preparation

It is not possible to enter programming mode during play. Verify whether the Player is playing. If playing, stop the player with the **STOP** button.

Operation

1. Press the **PROGRAM** button to enter the programming mode. "PROGRAM" is displayed in the display window.



2. Specify the disc by the **DISC (1 through 3)** button and then the track by the number keys successively. You can program up to nine (9) tracks by repeating this procedure.
3. To play the programmed track press the **▶ SELECT (PLAY)** button.

Notes

- The track number playing, next track programmed, and number of programmed tracks are displayed from the left-top of the television screen. You may use the **ON SCREEN** button to delete this information.
- Once the programmed track is played, it is deleted from the program.
- You may continue to program even while the disc is playing.

Canceling a programmed track

Operation

There are three (3) canceling functions (canceling the last programmed track, canceling the current track, canceling the next track to be played).

- To cancel the last programmed track press the **CANCEL** button on the remote control and the last programmed track will be canceled. This can be done while a disc is playing.

PROGRAMMED SONGS	
2-1	3-1
2-2	1-1
2-3	1-2
2-4	1-3
2-5	

(Television screen)

The number located lowest is the latest track programmed.

- To cancel the current track press **■ STOP** button.
- To cancel the next track, wait until the current track has finished and press the **▶▶|** button and the next track will be canceled and the unit will go to the next programmed track.

Note

To verify the tracks you programmed, stop the Player and see **ON SCREEN** information

Clearing a program

To delete all programmed tracks you have entered, press the ■ STOP button and then the PROGRAM button. "PROG OFF" will be displayed on the television screen.

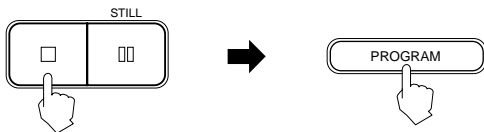

Note
The Player does not cancel the track program even if the ■ (STOP) button is pressed. Pressing the ► SELECT (PLAY) button again causes the Player to resume playing from the next track.

Repeating tracks

It is possible to repeat all discs or only a single track.

Preparation
This function is controlled by the remote control.

Operation
By pressing the REPEAT button, channel REPEAT modes are cycled as shown below.

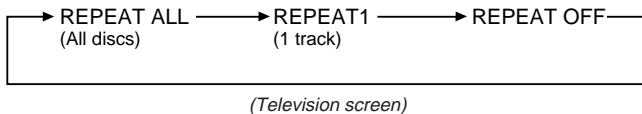
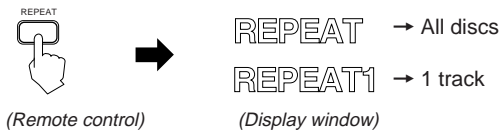

- Notes**
- When playing a programmed sequence of tracks, only one track repeat is available.
 - Only REPEAT1 is available in KARAOKE mode.
 - The Repeat function is not available when the player is set to PBC ON.
 - Only REPEAT ALL is available when the player is in RANDOM mode.

Randomly playing tracks

- Preparations**
- This function is controlled by the remote control.
 - The RANDOM button is effective only in NORMAL/PBC OFF mode.
 - This function plays tracks randomly from a single disc.

- Operation**
1. Stop the Player.
 2. Press the RANDOM button and random playing will start. "RANDOM" is displayed in the display window.

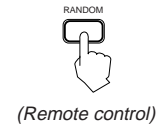

3. To cancel random playing, after stopping the Player [■ (STOP) button], press the RANDOM button again.

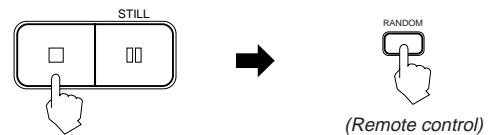

- Note**
- Random is not effective in program or KARAOKE mode.
 - Only REPEAT ALL is available when in RANDOM mode.

Playing a multiplex sound CD

This function is used for multiplex sound discs.

Operation
By pressing the MPX button, channel multiplexing modes are cycled as shown below.

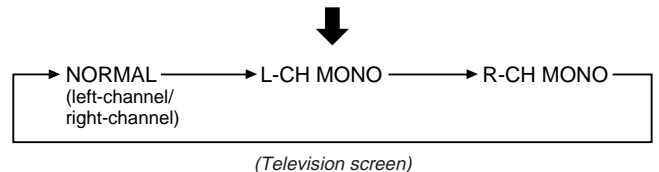

Viewing the VIDEO INTRO of a video CD

Preparation

When you play a video CD with the Playback Control function, the mode switch is recommended to be in the PBC OFF mode or KARAOKE mode.

Operation

1. Play the disc you want to see a digest of.
2. Press the VIDEO INTRO button on the Player or the remote control just after starting disc play. Then the Player starts to display in sequence the first five (5) seconds and track numbers of all tracks on the disc.

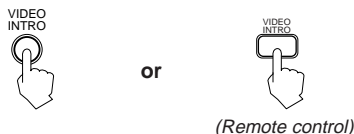

3. To select a track during digest display, press the number key corresponding to the item number on the television screen.

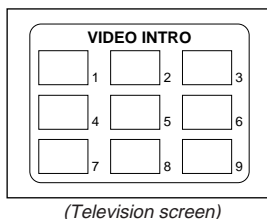

Programming during VIDEO INTRO

Operation

1. Stop play.
2. Press the PROGRAM button so that PROGRAM is lit in the display.
3. Press the disc button you want to play, and enter 1 on the keypad.
4. Press the ► button and then, after the disc has started to play, press the VIDEO INTRO button.
5. The Player starts to display in sequence the first five (5) seconds and track numbers of all tracks on the disc. Select the number you want to program. You can program nine (9) tracks.
6. Press the ► button to play.

Viewing the highlights of a video CD

This function is used for a movie video CD.

Preparations

- When you play a video CD with the Playback Control function, the mode switch is recommended to be in the PBC OFF mode or KARAOKE mode.
- This function is controlled by the remote control unit.

Operation

1. Start playing the track you want to see the highlights of.
2. After the track begins to play, press the HIGHLIGHT button on the remote control.

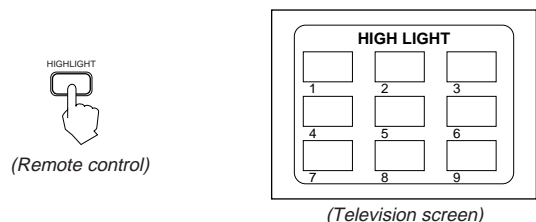

3. To select one of the nine (9) segments, press the number key (1 to 9) of the segment which you want to play.

Notes

- When you choose a highlight it will start from five (5) seconds before the shown time below each segment.
- The highlights show the proceeding five (5) seconds up to the displayed time on each highlight.
- The segments are each of nine (9) equal-time period divisions of the track.
- Nine (9) different highlights are displayed for one (1) minute.
- If no highlight is chosen in the one (1) minute period in normal mode or PBC OFF mode the next nine (9) segment highlights will begin, in KARAOKE mode highlights will stop.
- While in VIDEO INTRO or HIGHLIGHT, sometimes image is garbled partially. This symptom is caused by noise in the disc itself or incorrect manufacturing, it is not caused by a malfunction of the Player.

Selecting the surround mode

You can change the sound ambiance using the Surround function.

Operation

1. Choose from among the following three surround modes to change the disc mood.

- CLUB:** A more intimate sound with greater resonance and bass.
- HALL:** Enhances the mid-frequency range (which the human voice occupies), imitating the effect achieved in a concert hall.
- STADIUM:** Adds presence and spreads the sound, like in a stadium.

2. To select the surround mode, push the SURROUND button until the name of the desired sound mode appears on the television screen and in the display window.

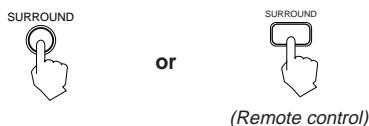

Each time you press the button, you toggle the mode as follows:

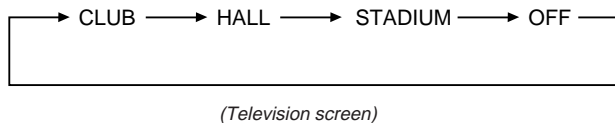

3. To cancel the effect, press the SURROUND button until the word "OFF" appears on the television screen.

Note

- When the Player is in one of the three Surround modes, you cannot use the key control, digital echo, vocal replace and MPX functions.

Playback with the Bookmark function

Marking a segment for later viewing with the Bookmark function

The Bookmark function lets you mark a segment of a Video CD, so that you can have almost instant playback of a desired scene later.

Even if you take the disc out of the player, its bookmark will stay recorded for later use, until you erase them, or disconnect the power cord.

Operation

While playing the disc, press the BOOKMARK button at the segment you want to mark for later playing.

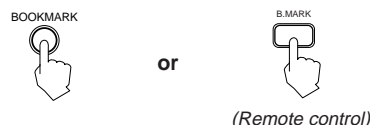

Notes

- The Bookmark function works only with Video CDs.
- You can register one bookmark in a single disc and registration for up to ten discs is possible.
- The Bookmark function is most easily used when the Player is in PBC OFF mode.
- If you mark a segment when the Player is set for the Playback Control (PBC) function, the mark is placed at the beginning of the scene.
- The Bookmark function does not work in Random and Program modes.
- When you disconnect the power cord, Bookmark registration is erased.

Playing the segment you marked

Press the BOOKMARK button when playback is stopped.

Canceling the bookmark

After pressing the BOOKMARK button to start playing the segment you marked, press CANCEL button.

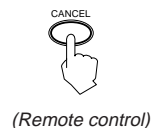

Using a microphone

Using a wired microphone

Operation

1. Insert the connector cable to the end of the microphone.
2. Up to three (3) microphones can be connected to the MIC jacks on the front panel.

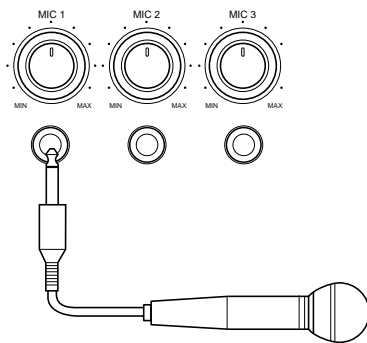

3. Switch the microphone's power on.
4. Turn the MIC 1 through MIC 3 knobs clockwise (level up) or counterclockwise (level down) as desired.

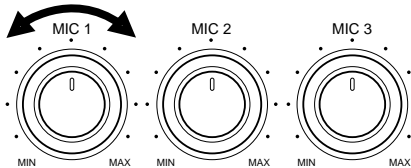

ATTENTION

When you are not using the microphone, to set the MIC switch to **OFF**; otherwise the batteries will discharge even when not in use.

Using a wireless microphone

Antenna preparations

You need to connect the FM antenna to the back of the player.

- Open the FM antenna wire connectors by pushing them to the side, insert the FM antenna wires, and close them by pushing them back into their original position.
- Attach the FM feeder antenna to the wall behind the player so that the wire forms a "T" as illustrated.

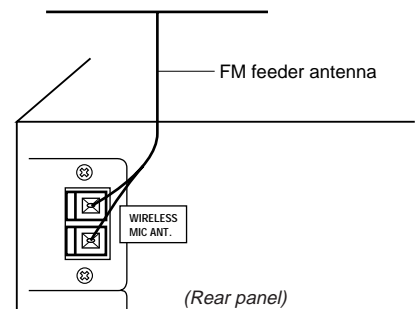

Microphone operation

1. Insert the antenna cable into the end of the microphone as illustrated and turn it clockwise to secure it.

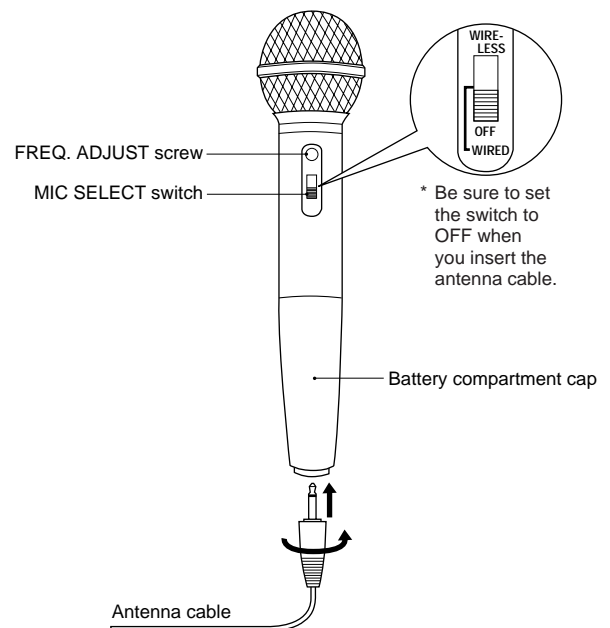

* Be sure to set the switch to **OFF** when you insert the antenna cable.

2. Press the WIRELESS MIC button on the front panel.



VARIOUS UNIQUE FUNCTIONS

3. Set the MIC SELECT switch to "WIRELESS".
4. When the indicator turns green, the wireless microphone has been accepted. If the tuning is not proper (noise or no voice output from the speaker because of interference from TV signals etc.), the indicator turns red.

You can use up to four (4) microphones (3 wired and 1 wireless) at the same time.

5. The wireless microphone voice is mixed into MIC 3. Wireless microphone volume adjustment is performed with the MIC 3 knob.

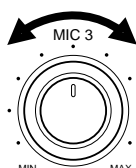

Note

The maximum operating distance of the wireless microphone is about 10m. (This may change depending on room conditions.)

If there is interference when using the wireless microphone

If the indicator turns green in spite of the microphone switch being off, or no voice is output from the speaker because of interference from TV signals etc., continue with the next step.

Operation

1. Try to tune the microphone frequency. First, adjust the FREQ. ADJUST screw in the rear panel using the provided screwdriver, until the interference is gone.

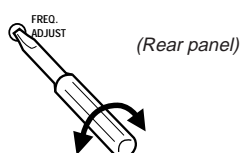

2. Then set the MIC SELECT switch to "WIRELESS".
3. While speaking into the microphone continuously turn the microphone's FREQ. ADJUST screw with the provided screwdriver until the indicator on the front panel button turns green.

Note

When you adjust the frequency, be sure to use the provided screwdriver. Metal head screwdrivers may not adjust correctly or may damage parts inside.

Using a wireless microphone as a wired microphone

When the batteries are dead or interference is too strong, you can use a wireless microphone as a wired microphone.

Operation

Insert the connector cable to the end of the microphone and set the MIC SELECT switch to "WIRED".

Note

- Normally, when not using the microphone as wireless, the WIRELESS MIC button should be off.

Adjusting music key

Press the KEY CONTROL buttons (\flat or \sharp) to change the key in which the music plays. To return the music to its original key, press the NORMAL button.

You can adjust the music using the remote control unit also.

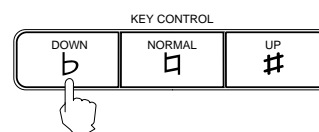

Notes

- The degree the key has been sharpened or flattened is displayed on the television screen.
- When the song ends the key control will return to NORMAL mode automatically.

Adjusting echo effect

Turn the DIGITAL ECHO knob clockwise (level up) or counter-clockwise (level down) to adjust the echo effect as desired.

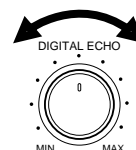

Vocal replace

Preparation

This function is used for multiplex sound discs.

Operation

1. Press the **VOCAL REPLACE** button during play or stop. **REPLACE** will appear on the display window and **VO.REPLACE** will appear on the television screen. When you start singing, the disc vocal is removed and your voice is inserted into the music.

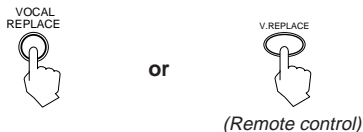

2. To cancel voice replacement, press the **VOCAL REPLACE** button again.

Note

- You cannot use the Vocal Replace function with a disc that has vocals recorded on the left channel.

ATTENTION

Be sure to remove the microphone

Note when connecting the sound output to the input of a TV or VCR: If an excessively strong signal is given to a unit through a microphone, for example when using Karaoke, it may cause an adverse effect such as distorted sound. Lower the sound volume using the microphone control.

Karaoke etiquette

Think of your neighbors when you are enjoying karaoke music. Particularly late at night, the sound you enjoy may reach your neighbors more than you expect. Common sense and courtesy are always appreciated.

OPERATION OF PLAYBACK CONTROL FUNCTION

Playing Video CDs with Playback Control function

This Player provides a Playback Control function which utilizes a procedure (menu selection) programmed in a video CD. The playback operation procedure may differ depending on the disc you use.

The Playback Control function is described below and in the figure.

- High-resolution still image display - Super-fine reproduction of still images with more than 4 times the resolution of video tape.
- Menu-driven playback - interactive menus for easy selection of tracks

Preparations

- A video CD with the Playback Control function is required for this operation.
- Only the NORMAL mode can be used.
- The buttons available for use are the number keys, the **PREV/NEXT** buttons, **SELECT** button, **DISC (1 through 3)** buttons, and **RETURN** button.

Button functions

- Number keys Select a specific menu item from the television screen or monitor.
(Including +20 button and +10 button)
- PREV/NEXT** buttons .. Move through menu.
- SELECT** button Starts up a video CD with the PBC function in DISC tray 1 to 3.
- DISC (1 through 3)** buttons Start up a video CD with the PBC function in the specified DISC tray.
- RETURN** button Returns to the menu.

Operation

1. Verify that the Player is in NORMAL mode.
2. Press the **DISC (1 through 3)** or **SELECT** button, and then the Player starts up the PBC function. "Pb" is shown in the Display window. The main menu, "PBC", and disc/track number are displayed on the television screen.

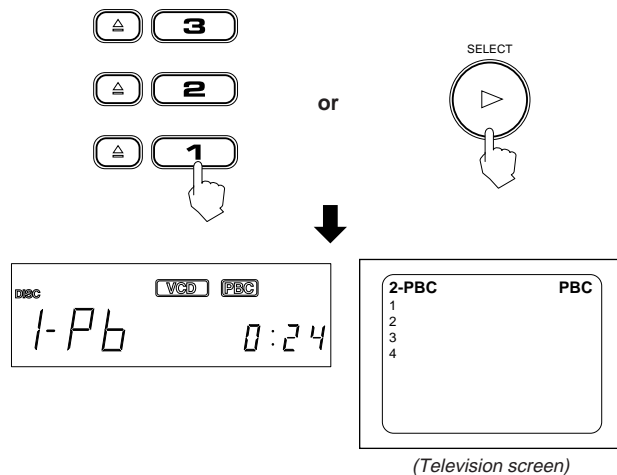

3. To move through the menus, press the **PREV/NEXT** buttons.



4. When the menu you want appears, select an item in the menu by using the number keys. The numbers on the number keys correspond to the menu item numbers.
5. To return to a menu and stop the track being played, press the **RETURN** button.



Notes

- Page numbers in the menu show that preceding pages exist. To move from the current menu, press the **PREV/NEXT** buttons.
- If you have no desire to use the PBC function when playing a disc with the PBC function, switch the MODE switch to "PBC OFF" before playing.
- When you change the mode switch except NORMAL mode during play Playback Control disc, the play stops, so reset again from the beginning.
- If you press number keys directly to select the track, you can't enter the Player into PBC mode.

Video CD with Playback Control function

What is Playback Control function?

The Playback Control function, ushering a new video CD age, allows you to enjoy menu-driven operation and high-resolution still images having a resolution four times greater than moving pictures.

- **Menu-driven playback**
You can interact with the screen using a menu display to select and play an entry.
- **High-resolution still image display**
You can display high-quality images four times clearer than moving pictures.

Example of playback by the Playback Control function

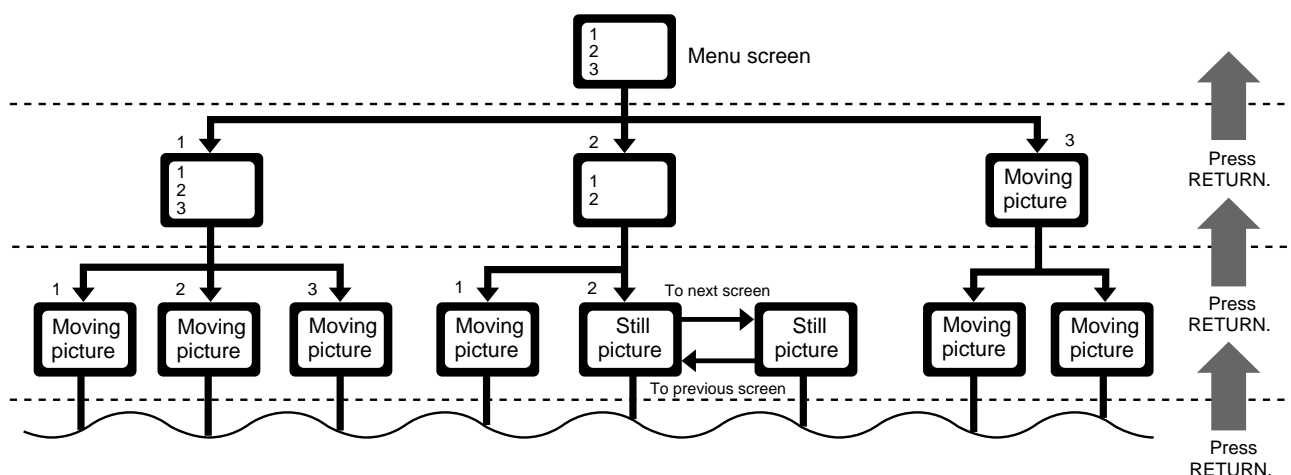

A selection menu is displayed when you start playing a video CD disc with the Playback Control feature. The selection menu shows a list of numbers for selection. Some discs may show moving pictures or a divided screen.

1. When a list of numbers is displayed, selecting a number shows its contents.
2. When a moving picture is displayed, pressing SELECT at the time when a part of the movie you desire is shown plays the movie.

3. When the selection menu is redisplayed after you have played your selection, selecting a number again can replay its contents. (Some discs may show the menu screen several times.) When "Next" and "Prev" are shown, pressing "NEXT" or "PREV" can change the selection menu.

4. After playback, press RETURN to go back to the previous screen.

Note

When a menu is displayed for a long time, about 10 minutes, the screen background automatically fades out to prevent screen burn-in while the setting is suspended.

GRAPHIC/DIGITAL AUDIO CDs

Playing CD Graphics/ digital audio CDs

Playing CD Graphics

Basic video CD-playing procedures apply although the pictures are still. A CD Graphics is identified by "CD-G" shown on the display.

Notes

- The following operations may distort the image on the screen.
 - Searching for starting point of music
 - Fast forwarding/reversing
 - Stop/pause
- If paused, the screen changes to blue in a few minutes. This is to prevent burn-in of the TV screen.

Playing digital audio CDs

Basic video CD-playing procedures apply to the reproduction of sound.

Note

No indicator will turn on to show the type of the disc on the display.

SPECIFICATIONS

Main specifications

XL-MV558GD

Model	Video CD player	
Playback disc	Video CD (with/without Playback Control function) CD Graphics Digital Audio CD	
Total harmonic distortion	0.01% (1kHz)	
S/N ratio	93 dB	
Frequency response	20Hz – 20kHz	
Input terminal	Microphone	2 mV (9.1 k)
Output terminal	Line output	2.0 Vrms (full scale)
	Image output	1.0 Vp-p (75)
	Video (composite)	
Echoing	Digital echoing	
Power requirements	AC 115-127/220-240V \sim , 50/60Hz adjustable with the voltage selector	
Power consumption	22 watts 5 watts (in standby mode)	
Mass	5.4 Kg (11.9 lbs)	
Dimensions	447x 127 x 340.3 mm	
	17-11-16 x 5 x13-7/16 inches	

Accessories

AC power cord	1
Audio video cord	1
Remote control unit (RM-SXMV558U)	1
Batteries (R6P(SUM-3)AA(15F))	2
Microphone	1
FREQ.ADJUST screwdriver	1
FM feeder antenna	1
Connector cable	1
Antenna cable	1
Batteries (R6P(SUM-3)/AA(15F))	2

TROUBLESHOOTING

Troubleshooting

What appears to be a malfunction may not always be serious. Please go through the following list before requesting service.

Symptom	Possible cause	Remedy
Power does not come on.	Power plug is disconnected from AC outlet.	Firmly connect the plug to AC outlet.
	Battery is exhausted.	Replace the battery with a new one.
Remote control does not work.	The tip of the remote controller is not pointed at the right receiving part of the player.	Use the remote control correctly.
No image is displayed on the monitor.	The video cable is not connected.	Firmly connect the cable.
	The TV is not set in video mode.	Set the TV in video mode.
	An incompatible disc is loaded.	Load a disc compatible with the player.
Playback does not start.	No disc is loaded.	Load a disc.
	Disc is loaded upside down.	Reload the disc with the label up.
Speaker does not produce sound.	Audio cable is not connected.	Firmly connect the cable.
	Operation of the external amplifier is wrong.	Operate the amplifier correctly.
Sound is distorted or noise is generated. Image is garbled.	Disc is dirty.	Wipe off the disc surface with a soft cloth.
	Connection is wrong.	Correctly connect cables. (See page 2.)
Sound is intermittent. Image is garbled.	Disc is dirty.	Wipe the disc surface with a soft cloth. (See page 1)
	Disc is scratched.	Replace the disc with a new one.
	Disc is warped.	
Disc tray does not come out when OPEN/CLOSE button is pressed.	Power plug is disconnected from the power outlet.	Firmly insert the plug into the outlet.
Operation is not possible.	Microcomputer malfunctions due to lightning or static electricity.	Turn off the power, then on again.

The malfunction may be caused by a device other than the player. Check other devices connected to the player.

We would like to thank you for purchasing one of our JVC products. Before connecting this unit to the wall outlet, please read the instructions carefully to ensure that you obtain the best possible performance. If you have any questions, please consult your JVC dealer.

Table of contents

GENERAL INFORMATION	1
Care and handling of compact discs	1
BEFORE USING FOR THE FIRST TIME	2
Basic Connections	2
Connecting player to a TV or amplifier using the Audio Video cord	2
Video out select	2
Connecting the power cord	2
Installing batteries	3
Putting batteries in the remote control	3
Putting batteries in the microphone	3
OVERVIEW OF CONTROLS	4
Left front panel of the Player	4
Center front panel of the Player	4
Right front panel of the Player	4
On the remote control unit	5
BASIC OPERATIONS	6
Now you can play a variety of video CDs!!	6
Overview of the three modes	6
Triple disc tray usage	6
Description of the display window	6
Preparation for playing	7
Inserting/removing the disc(s)	7
Starting to play disc(s)	7
Using number keys	7
Stopping play	8
Pausing play	8
Auto search/Manual search	8
Using stereo headphone	8
Using the remote control	9
Presetting the remote control to operate your own TV	9
Using the SHIFT button on the remote control unit	9
Preset code table	10
VARIOUS UNIQUE FUNCTIONS	11
Various functions can enhance your enjoyment	11
Display of operations status	11
Programming the track sequence you want	11
Canceling a programmed track	11
Clearing a program	12
Repeating tracks	12
Randomly playing tracks	12
Playing a multiplex sound CD	12
Viewing the VIDEO INTRO of a video CD	13
Programming during VIDEO INTRO	13
Viewing the highlights of a video CD	13
Selecting the surround mode	14
Playback with the Bookmark function	14
Marking a segment for later viewing with the Bookmark function ...	14
Playing the segment you marked	14
Canceling the bookmark	14
Using a microphone	15
Using a wired microphone	15
Using a wireless microphone	15
If there is interference when using the wireless microphone	16
Using a wireless microphone as a wired microphone	16
Adjusting music key	16
Adjusting echo effect	16
Vocal replace	17
OPERATION OF PLAYBACK CONTROL FUNCTION	18
Playing Video CDs with Playback Control function	18
Video CD with Playback Control function	19
GRAPHIC/DIGITAL AUDIO CDS	20
Playing CD Graphics/digital audio CDs	20
Playing CD Graphics	20
Playing digital audio CDs	20
SPECIFICATIONS	21
Main specifications	21
TROUBLESHOOTING	22
Troubleshooting	22

Main (AC) Line Instruction (not applicable for Europe, U.S.A., Canada, Australia and U.K.)

主 (AC) 電源線路說明（不適用於歐洲、美國、加拿大、澳洲及英國型號）

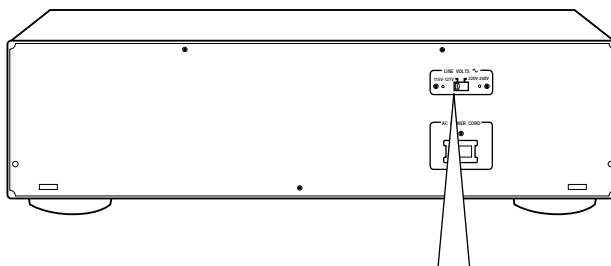

IMPORTANT for main (AC) line

BEFORE PLUGGING IN, do check that your main (AC) line voltage corresponds with the position of the voltage selector switch provided on the outside of this equipment and, if different, reset voltage selector switch, to prevent damage or risk of fire/electric shock.

有關主(AC)電源線路的重要事項

接插電源以前，務請檢查當地的主(AC)電源線路電壓是否和位於本機外面的電壓選擇開關設定的位置一致。如果不一致，即重新設定電壓選擇開關使符合當地電壓，以免損壞機器或引起火災/觸電的危險。