

**Kramer Electronics, Ltd.**



# **USER MANUAL**

**Models:**

**SV-551, SV-551 ALC**

*Processor / Switcher SummitView™ Essentials Kit*

## Contents

<b>1</b>	<b>Introduction</b>	<b>1</b>
<b>2</b>	<b>Getting Started</b>	<b>1</b>
<b>PART I</b>	<b>Your SummitView™ System</b>	<b>2</b>
<b>3</b>	<b>Overview</b>	<b>2</b>
3.1	Your SummitView™ Essentials Kit and SV-551 ALC	2
3.2	Quick Start Configuration Setup	3
3.3	8-Step Essentials Kit Quick Installation Guide	4
<b>PART II</b>	<b>The SV-551 SummitView™ Processor/Switcher</b>	<b>6</b>
<b>4</b>	<b>Defining the SV-551 SummitView™ Processor/Switcher</b>	<b>6</b>
4.1	DDC Support	9
<b>PART III</b>	<b>Detailed Installation Instructions</b>	<b>10</b>
4.2	Defining the RC-63DL Room Controller	10
4.3	Defining the SV-301 and SV-302 Wall Plates	12
4.4	SV-301 and SV-302 (U.S.)	13
4.5	SV-301 and SV-302 (England and Europe)	14
4.6	Connecting the Wall Plates	15
4.7	Operating the SV-551 Remotely	17
<b>5</b>	<b>Installing Optional Ceiling Speakers</b>	<b>18</b>
5.1	Choosing the Best Location	18
5.2	Cutting the Ceiling Tile	18
5.3	Installing the Closed-back Ceiling Speakers	19
5.4	Painting the Speaker	23
5.5	Connecting Several Speakers	23
5.5.1	Adjusting the Tap Selector	24
5.6	Connecting the SV-551 SummitView™ Processor/Switcher	25
5.7	Operating the SV-551 Remotely	26
5.8	Installing the SV-551 in a 19” RK-551 Rack (Option)	27
<b>PART IV</b>	<b>Further information</b>	<b>28</b>
<b>6</b>	<b>ADA Requirements</b>	<b>28</b>
<b>7</b>	<b>Customizing the Controllers' Buttons and Labels</b>	<b>30</b>
7.1	Backlit Buttons	30
7.2	Button Labels Sheet	31
<b>8</b>	<b>Wiring the CAT 5 LINE IN/LINE OUT RJ-45 Connectors</b>	<b>31</b>
8.1	Wiring the CAT 5 RJ-45 Terminals (U.S.)	32
8.2	Wiring the Terminal Block Connector (England and Europe)	32

<b>9</b>	<b>SummitView™ System Cables</b>	<b>33</b>
<b>10</b>	<b>SummitView™ Cable Termination (Connector-to-Cable)</b>	<b>35</b>
<b>11</b>	<b>Technical Specifications</b>	<b>37</b>
<b>12</b>	<b>Detachable SummitView™ Essentials Kit Check List</b>	<b>39</b>

## Figures

Figure 1: SV-551 SummitView™ Processor/Switcher	7
Figure 2: SV-551 Processor/Switcher Underside	7
Figure 3: Connecting the SV-301 to the SV-551	15
Figure 4: Connecting the SV-302 to the SV-551	16
Figure 5: Connecting the SV-303/SV-304/SV-305 to the SV-551	17
Figure 6: Closed-back Ceiling Speakers	19
Figure 7: Installing the Closed-back Ceiling Speakers	20
Figure 8: Wiring a Pair of Speakers to the SV-551	21
Figure 9: Plugging and Securing the Cables	21
Figure 10: Tighten the Mounting Tabs	22
Figure 11: Closed-back Ceiling Speaker Schematic Diagram	24
Figure 12: Adjust Tap Selector	24
Figure 13: Connecting the SV-551 SummitView™ Processor/Switchers	25
Figure 14: Wiring the K-Net Connector	26
Figure 15: Overhead and Side Clearance Requirements	28
Figure 16: High/Low Forward, Side, and Over Obstruction Reach Limit Requirements	30
Figure 17: Sample "Button Labels" Sheet	31
Figure 18: Stickers affixed to Cables	36

## Tables

Table 1: Quick Installation Guide for the SummitView™ Standard Kit	4
Table 2: SV-551 Front, Rear, and Underside Features	7
Table 3: Defining the RC-63DL	11
Table 4: Defining the SV-301 and SV-302 (U.S.)	13
Table 5: Defining the SV-301 (England and Europe)	14
Table 6: Defining the SV-302 (England and Europe)	14
Table 7: Closed-back Ceiling Speakers Hardware Items	20
Table 8: CAT 5 Pinout (U.S.)	32
Table 9: Terminal block Connector Pinout (England and Europe)	33
Table 10: Cables included with the SV-551 SummitView™ Essentials Kit and SV-551 ALC	33
Table 11: Additional Recommended Cables for the SV-551 SummitView™	35
Table 12: SummitView™ Cable Termination	35
Table 13: Technical Specifications of the SV-551	37
Table 14: SummitView™ Essentials Kit Check List	39

## 1 Introduction

Welcome to Kramer Electronics! Since 1981, Kramer Electronics has been providing a world of unique, creative, and affordable solutions to the vast range of problems that confront the video, audio, presentation, and broadcasting professional on a daily basis. In recent years, we have redesigned and upgraded most of our line, making the best even better! Our 1,000-plus different models now appear in 11 groups<sup>1</sup> that are clearly defined by function.

Congratulations on purchasing your Kramer SummitView™ system! This user manual comprises of four parts:

**PART I:** A description of the SummitView™ system, its devices including a quick start section

**PART II:** A definition of the **SV-551** SummitView™ *Processor/Switcher*

**PART III:** Detailed installation instructions - installing the Wall Plates, the Ceiling Speakers, and the **SV-551** SummitView™ *Processor/Switcher*

**PART IV:** Further information

## 2 Getting Started

We recommend that you:

- Unpack the equipment carefully and save the original boxes and packaging materials for possible future shipment
- Check that your SummitView™ Kit is complete. Use the check list in [Table 14](#) to verify the contents of the kit
- Review the contents of this user manual<sup>2</sup>

---

1 GROUP 1: Distribution Amplifiers; GROUP 2: Switchers and Matrix Switchers; GROUP 3: Control Systems; GROUP 4: Format/Standards Converters; GROUP 5: Range Extenders and Repeaters; GROUP 6: Specialty AV Products; GROUP 7: Scan Converters and Scalers; GROUP 8: Cables and Connectors; GROUP 9: Room Connectivity; GROUP 10: Accessories and Rack Adapters; GROUP 11: Sierra Products

2 Download up-to-date Kramer user manuals from <http://www.kramerelectronics.com>

## PART I Your SummitView™ System

**PART I** describes the SummitView™ system and its devices

### 3 Overview

We have designed a complete and simple solution for the integration of media and control in classrooms, training rooms and presentation rooms. SummitView™ is as easy to use as it is to specify and install. The components that make up the SummitView™ system are available as either standalone products or as a Kit with everything included - wall plates, room controllers, amplifier, speakers, cable and enclosures ready to be mounted to projection mounts is included. With SummitView™ you get everything you need for a high end integrated media system – just add the displays and sources. All the signals are transmitted over economical CAT 5 cable and switched using the **SV-551 Switcher/Processor**. The SummitView™ System controlled via the network is everything you need from the company you can count on for quality products and the ultimate in customer support – Kramer Electronics.

The **SV-551 ALC** version is aimed at installers who prefer to design their own SummitView installations. The **SV-551 ALC** kit differs from the standard **SV-551** kit only in regards to the contents of the box.

#### 3.1 Your SummitView™ Essentials Kit and SV-551 ALC

This section defines the SummitView™ Essentials Kit and the **SV-551 ALC** box contents.

The SummitView™ Essentials Kit contains:

- **SV-551** Processor/Switcher
- **RC-63DL** Room Controller
- **SV-301** and **SV-302** *Wall Plate Devices*
- **SPK-CC444** *Speakers* (ordered separately)
- Required cables (for full details see [Section 9](#))
- Check List (see [Table 14](#))
- Screwdrivers (provided with the **RC-62**, **RC-63** and **SV-551**)

The **SV-551 ALC** kit contains:

- **SV-551** Processor/Switcher
- Reduced cable set (for details, see [Section 9](#))

The following additional products are available for purchase (optional):

- **SV-301, SV-302, SV-303, SV-304, and SV-305** *Wall Plate Devices*<sup>1</sup>
- RC-62 Series (**RC-62, RC-62L**), RC-63A Series (**RC-63A, RC-63AL**), and RC-63D Series (**RC-63D, RC-63DL**) *Room Controllers*<sup>2</sup>
- SPK-CC688, SPK-CC448, SPK-CC348F *Speakers*
- MT-P9P 9” and MT-P6P 6” center pole sections for the SV-1 Mounting Box which can be attached to any 1.5NFS projector mounting system
- SV-1 Pole Mounting Box which can be attached to any 1.5NFS projector mounting system
- Additional TP cables (see [Section 9](#))

The following items are not provided by Kramer:

- Projector (or display device)
- Screen (and mounting hardware)
- Source devices, such as, DVD/VCR player, scanner, or computer

To achieve the best performance:

- Consider the condition of the room—its size, the way it is arranged, whether the walls and ceiling are drywall or cement—that may limit where and how you can install SummitView™, where required, refer to the ADA requirements (see [Section 6](#))  
Where an internal installation is impractical (for example, if the walls and ceiling are constructed of cement and you do not want to drill inside them), you can install the SummitView™ Kit externally, that is, install the **SV-551** in a rack (see [Section 5.8](#))
- Connect only good quality connection cables and avoid interference from neighboring electrical appliances and position your SummitView™ away from moisture, and excessive sunlight

	<b>Caution:</b> No operator serviceable parts inside unit
	<b>Warning:</b> Use only the Kramer Electronics input power wall adapter that is provided with the unit
	<b>Warning:</b> Disconnect power and unplug unit from wall before installing or removing the device or servicing unit

## 3.2 Quick Start Configuration Setup

Refer to the color configuration page included with your SummitView™ Kit.

1 Download the user manual: **SV-301, SV-302, SV-303, SV-304, SV-305** from <http://www.kramerelectronics.com>

2 Download the user manual: **RC-62, RC-63A and RC-63D** Series from <http://www.kramerelectronics.com>

### 3.3 8-Step Essentials Kit Quick Installation Guide

This data summarizes how to install your SummitView™ Essentials Kit (similar principles apply if you are installing other SummitView™ configurations).

*Table 1: Quick Installation Guide for the SummitView™ Standard Kit*

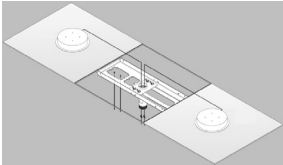
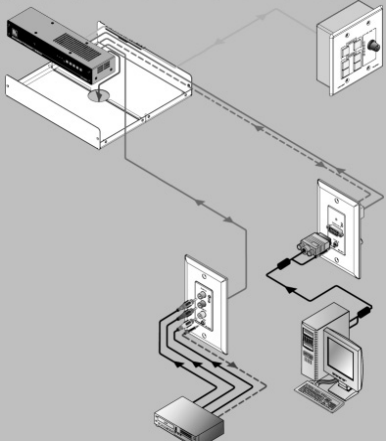
Description	
<p><b>1 Prepare the openings for the Wall Plates SV-301 and SV-302, and the Room Controller RC-63DL</b></p>	
<p><b>2 Route the wiring from the proposed location of the SV-551 via:</b></p> <ol style="list-style-type: none"> <li><b>1. Two STP cables<sup>1</sup> to the intended SV-301 location</b></li> <li><b>2. One STP cable to the intended SV-302 location</b></li> <li><b>3. K-NET cabling to the intended RC-63DL location</b></li> <li><b>4. Speakers cabling to the speakers' intended location</b></li> <li><b>5. If the SV-551 and/or the RC-63DL are to be used as room controllers, route the appropriate control cables to their intended locations</b></li> </ol>	
<p><b>3 Install the Wall Plates by connecting the:</b></p> <ol style="list-style-type: none"> <li><b>1. STP cables to the wall plates and installing the wall plate</b></li> <li><b>2. BCP-KNET-50 cable to the RC-63DL and installing the RC-63DL (see <a href="#">Section 7</a>)</b></li> </ol>	
<p><b>4 Install the Ceiling Speakers</b></p>	

<sup>1</sup> There are two types of STP cable provided with SummitView™: CP-STP-50 (plenum-rated for the SummitView™ US) or C-STP-50 (non-plenum for the SummitView™ Europe)

**Description**

**5 Connect the appropriate wiring—STP, and BCP-2S-25—from the wall plates and the RC-63DL and from the SV-551 to the speakers**

**6 Connect the cables to the SV-551**

**7 Install the projector and the screen. Connect the projector to the SV-551 video outputs using the supplied video cables. Connect the RS-232 cable between the SV-551 and the projector.**

**8 Turn ON the SV-551 and the projector. By choosing the input channels of the SV-551 (from the front panel buttons) and of the projector you should be able to switch between inputs connected to the different wall plates**



## PART II The SV-551 SummitView™ Processor/Switcher

**PART II** defines the **SV-551** SummitView™ Processor/Switcher

### 4 Defining the SV-551 SummitView™ Processor/Switcher

The Kramer **SV-551** SummitView™ *Processor/Switcher* is designed specifically for the SummitView™ system and is an integral part of it. It fits inside the **SV-1** housing. The **SV-551** can only be controlled via the default **RC-63DL** or via one of the other (optional) controllers: **RC-62** and **RC-62L**, or the **RC-63A**, **RC-63AL** and **RC-63D**. The **SV-551** features CAT 5 video and audio inputs (including optional DDC for VGA). It also has an IR output for video sources and features a Master controller, as well as a power amplifier and audio line out. The **SV-551** front panel controls include five input selector buttons, three LEDs, and a USB port. It receives input signals via the RJ-45 CAT 5 connectors from the **SV-301**, **SV-302**, **SV-303**, **SV-304**, and the **SV-305** wall plate devices. The **SV-551** RJ-45 CAT 5 inputs include: two for video, three for computers, and three DDC connectors.

The **SV-551** has a projector output on a 15-pin HD connector, one component video on three RCA connectors, two composite video outputs, each on an RCA connector, and an s-Video output on a 4p connector. In addition, the **SV-551** features terminal blocks for a balanced stereo audio speakers output, terminal blocks for an AUX input, 10V volume, relays, RS-232, and RS-485. The **SV-551** is controlled by one of Kramer's SV controllers (**RC-62** or **RC-63**) via the proprietary communication channel K-NET, and can also be controlled via the Ethernet and/or the front panel input selector buttons. The **SV-551** is 12VDC fed.

Figure 1, Figure 2 and Table 2 define the SV-551 SummitView™ Processor/Switcher.

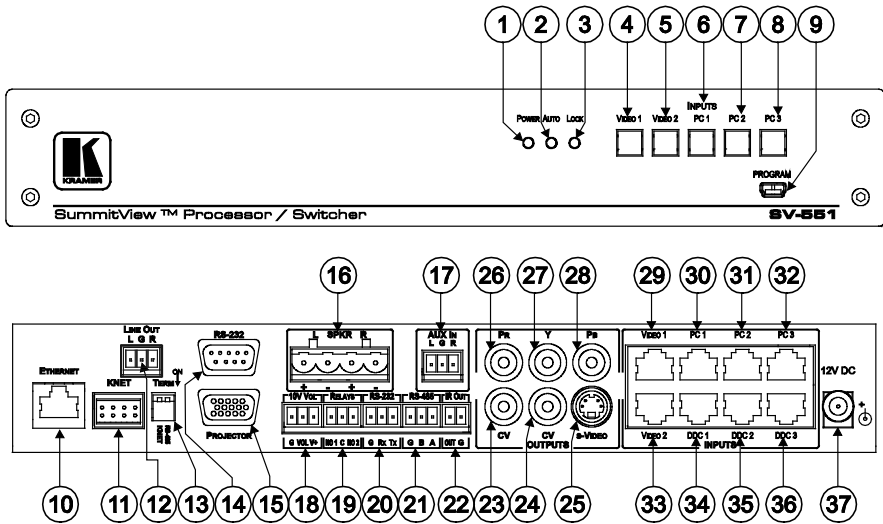

Figure 1: SV-551 SummitView™ Processor/Switcher

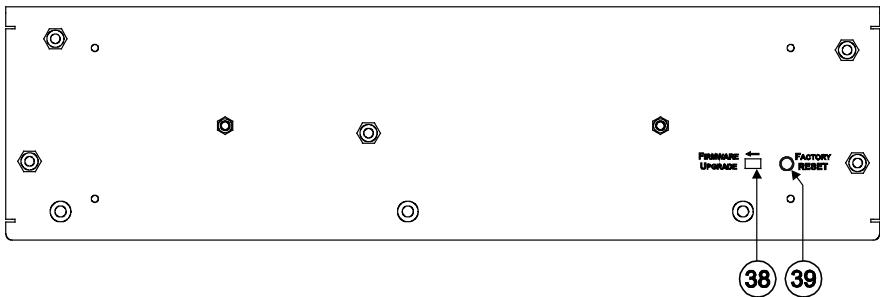
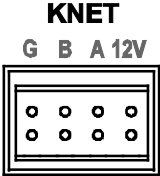

Figure 2: SV-551 Processor/Switcher Underside

Table 2: SV-551 Front, Rear, and Underside Features

#	Feature	Function
1	POWER LED	Lights when receiving power to the unit
2	AUTO LED	Lights when the unit is configured to automatically identify and select an input according to a set priority
3	LOCK LED	Lights when the front panel buttons are locked

## Defining the SV-551 SummitView™ Processor/Switcher

#	Feature	Function	
4	INPUT Buttons (used for testing)	VIDEO 1	Press to select the video source 1
5		VIDEO 2	Press to select the video source 2
6		PC 1	Press to select the PC 1 source
7		PC 2	Press to select the PC 2 source
8		PC 3	Press to select the PC 3 source
9	PROGRAM Connector	Connect to a computer for configuration of the unit (a USB cable is provided with the Controller)	
10	ETHERNET Connector	Connects to the PC or other Controller through computer networking, for control and configuration of the unit. Default IP settings: Address 192.168.1.39, port 50000, subnet mask 255.255.255.0	
11	K-NET <sup>1</sup> Connector	<p>PIN GND is for the Ground connection; PIN B (-) and PIN A (+) are for RS-485, and PIN +12V is for powering the unit. For details of how to connect K-NET, see <a href="#">Figure 14</a></p> <div style="text-align: center;">  <p><b>KNET</b> G B A 12V</p> </div>	
12	LINE OUT Terminal Block	Connect to an external audio amplifier	
13	TERM DIP-switches	DIP-switches for line termination of the unit (DIP-switch 1 is for KNET, DIP-switch 2 is for RS-485)	
14	RS-232 DB 9M Port	Connects to the projector for projector control	
15	PROJECTOR 15-pin HD connector	Connects to the projector	
16	SPKR Terminal Block	Connect to the left and right speakers	
17	AUX IN Terminal Block	Connect to an additional audio source for mixing it with the audio line level input (talk over)	
18	10V VOL Terminal Block	Connect to an external potentiometer on a wall plate <sup>2</sup> to adjust the volume of the speakers	
19	RELAY Terminal Block	Connect to a room item (such as lighting, screen settings, blinds, and so on)	
20	RS-232 Terminal Block	Connect to the RS-232 connector on the A/V equipment or a PC or other Serial Controller	
21	RS-485 Terminal Block	Connect to the RS-485 detachable terminal block on a switcher or PC	
22	IR OUT Terminal Block	Control a machine via an IR Emitter	
23	CV RCA Connector	Connect to the composite video 1 input of the projector	
24	CV RCA Connector	Connect to the composite video 2 input of the projector	
25	s-Video 4p Connector	Connect to the s-Video input of the projector	
26	PR RCA Connector	Connect to the component video input of the projector	
27	Y RCA Connector		
28	Pb RCA Connector		
29	VIDEO 1 RJ-45 Connector	Connect to the video 1 source via the CAT 5 socket on the rear of the SV-302 or SV-303	

<sup>1</sup> K-NET is a proprietary Kramer protocol for interconnecting Kramer units

<sup>2</sup> For example, the RC-63A

#	Feature	Function
30	PC 1 RJ-45 Connector	Connect to the PC 1 source via the CAT 5 socket on the rear of the <b>SV-301</b> . Alternatively, connect to a Component video source (via the <b>SV-304</b> or the <b>SV-305</b> ). The relevant DDC connector, when also connected, can be used for IR control of that source
31	PC 2 RJ-45 Connector	Connect to the PC 2 source via the CAT 5 socket on the rear of the <b>SV-301</b> . Alternatively, connect to a Component video source (via the <b>SV-304</b> or the <b>SV-305</b> ). The relevant DDC connector, when also connected, can be used for IR control of that source
32	PC 3 RJ-45 Connector	Connect to the PC 3 source via the CAT 5 socket on the rear of the <b>SV-301</b> . Alternatively, connect to a Component video source (via the <b>SV-304</b> or the <b>SV-305</b> ). The relevant DDC connector, when also connected, can be used for IR control of that source
33	VIDEO 2 RJ-45 Connector	Connect to the video 2 source via the CAT 5 socket on the rear of the <b>SV-302</b> or <b>SV-303</b>
34	DDC 1 RJ-45 Connector	Connect <sup>1</sup> to the CAT 5 socket on the rear of the <b>SV-301</b> (DDC option)
35	DDC 2 RJ-45 Connector	Connect <sup>1</sup> to the CAT 5 socket on the rear of the <b>SV-301</b> (DDC option)
36	DDC 3 RJ-45 Connector	Connect <sup>1</sup> to the CAT 5 socket on the rear of the <b>SV-301</b> (DDC option)
37	12V DC	+12V DC connector for powering the unit
38	FIRMWARE UPGRADE Switch	For technical support use only
39	FACTORY RESET Button	Press and hold while powering up the unit to reset the audio, switching and Ethernet settings to their factory default values

## 4.1 DDC Support

When establishing a VGA connection between a PC or laptop and a display device, a set of parameters known as EDID are exchanged between them, which is carried over the DDC channel. In some PC graphic cards and laptops, this information exchange is essential for proper VGA OUT operation.

When the **SV-551** is connected to the **SV-301** with two STP cables it supports DDC communication between the connected PC or laptop and the Display device used, thus ensuring trouble free VGA transmission.

For proper operation of the DDC support, select the appropriate PC IN channel of the **SV-551** before turning on the VGA OUT of your laptop.

---

<sup>1</sup> Connect to the DDC for the transfer of specification data from the display device to the source properties, such as maximum resolution and color depth. The video card can then use this information to ensure that the user is presented with valid options for configuring the display

## PART III Detailed Installation Instructions

**PART III** covers these topics: installing the Wall Plates, the Ceiling Speakers and the **SV-551**

We recommend that after deciding where you want to install the screen and the projector, you install in this order, the:

1. Cables and wires.
2. Room Controller and wall plates (see [Section 4.2](#) and [Section 4.3](#)).
3. Ceiling speakers (see [Section 5](#)).

### 4.2 Defining the RC-63DL Room Controller

This section defines the default Kramer SummitView™ **RC-63DL Room Controller**, which is included as part of the SummitView™ *Essentials Kit*.

The **RC-62** and **RC-63A** are also available for additional purchase (optional). Refer to the separate user manual: **RC-62**, **RC-63A** and **RC-63D Series**<sup>1</sup>. Note, that each SummitView™ kit comes with the appropriate set of cables included (see [Section 9](#)). Each room controller can be used as:

- A system controller for the SummitView™ system when connected via **K-Net** cable to the **SV-551 SummitView™ Processor/Switcher**. When used in this way no programming of the room controller is needed
- An advanced, standalone, wall-mounted room controller. When used in this way programming of the room controller is required<sup>2</sup>

The Kramer **RC-63DL** is a 2 Gang wall plate. It features 6 front panel buttons designed in 2 groups; 1 group of 2 buttons, and another group of 4 buttons. Each group can be programmed according to the user's requirements. LCD and plastic cap variations are available. It has a digital volume control adjustment knob with 5 LEDs.

The **RC-63DL** includes 2 relays for the simplified and centralized control of room functions (such as lighting, closing blinds, screen settings, and so on), an IR output, a bi-directional RS-232 port, and 2 **K-Net** ports. In addition, the **RC-63DL** features an IR-learner for the customized control of external sources, absorbing the IR commands from different remote transmitters. A USB port is included for programming the **RC-63DL** via a computer. [Table 3](#) defines the **RC-63DL**.

---

<sup>1</sup> It includes these models: RC-62, RC-62L (the RC-62 Series); RC-63A and RC-63AL (the RC-63A Series) and RC-63D and RC-63DL (the RC-63D Series)

Download it from <http://www.kramerelectronics.com>

<sup>2</sup> Refer to the separate online “K-Config Configuration Guide” at <http://www.kramerelectronics.com>

Table 3: Defining the RC-63DL<sup>1</sup>

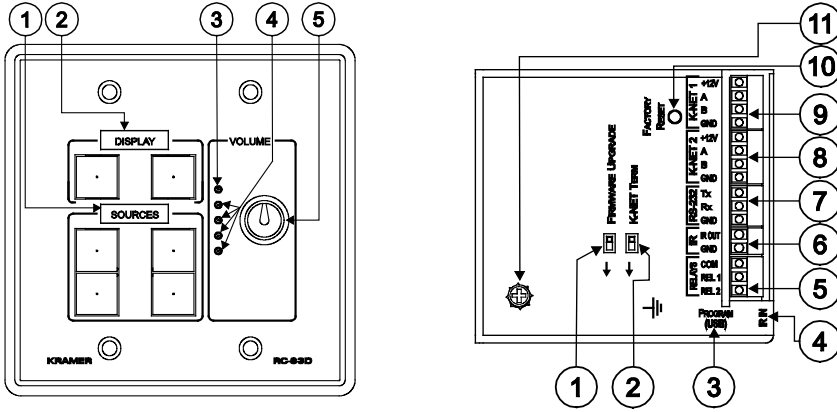

#	Feature	Function
1	<b>SOURCE Buttons</b>	These 4 configurable backlight buttons can set up any supported command (see <a href="#">Section 8.1</a> )  "SOURCES" is printed on the panel, or it is left blank to affix your own label (see <a href="#">Figure 17 in Section 7</a> ), or an LCD version on a blue background is available that displays up to 8 characters at once (programmed via the USB port) and includes rolling text
2	<b>DISPLAY Buttons</b>	These 2 configurable backlight buttons can set up any supported command (see <a href="#">Section 7.1</a> )  "DISPLAY " is printed on the panel, or it is left blank to affix your own label (see <a href="#">Figure 17 in Section 7</a> ), or an LCD version on a blue background is available that displays up to 8 characters at once (programmed via the USB port) and includes rolling text
3	<b>VOLUME LED</b>	Lights red, indicating maximum volume
4	<b>VOLUME LEDs</b>	Lights green, indicating volume level
5	<b>VOLUME Knob</b>	Rotate clockwise to increase the level

#	Feature	Function
1	<b>FIRMWARE UPGRADE Switch</b>	For technical support use only
2	<b>K-NET TERM Switch</b>	For line termination
3	<b>PROGRAM (USB) Connector</b>	Connect to a computer for unit configuration
4	<b>IR IN Receiver</b>	Receives IR remote commands
5	<b>RELAY Connections</b>	Connect to room items (such as lighting, screen settings, blinds, and so on)
6	<b>IR Connections</b>	Control a machine via an IR Emitter
7	<b>RS-232 Connections</b>	Connect to the RS-232 connector on the A/V equipment or a PC or other Serial Controller
8	<b>K-NET 2 Connections</b>	On K-NET 1 and K-NET 2, PIN GND is for the Ground connection <sup>2</sup> ; PIN B (-) and PIN A (+) are for RS-485, and PIN +12V is for powering the unit  (K-Net is a proprietary protocol for interconnecting Kramer units)
9	<b>K-NET 1 Connections</b>	
10	<b>FACTORY RESET Button</b>	Press and hold while powering up the unit to reset the audio, switching and Ethernet settings to their factory default values
11	<b>Grounding Screw</b>	Connects to the grounding wire

1 US version is shown. For the European version, see the RC-62, RC-63A and RC-63D Series user manual

2 The ground connection is sometimes connected to the shield of the RS-485 cable (in most applications, it is not connected)

### 4.3 Defining the SV-301 and SV-302 Wall Plates

The **SV-301** and **SV-302** are included as part of the SummitView™ *Essentials Kit*. Note, that each SummitView™ kit comes with the appropriate set of cables included (see [Section 9](#)). STP cabling 50' (15.24m)<sup>1</sup> long is provided for these wall plates (see [Section 9](#)) with the *Essentials Kit*. When required, longer STP cabling can be used, but we recommend a maximum distance of 100' (30.48m). Exceeding this recommended distance may result in reduced image quality. For the TP pinout see [Section 8](#).

The **SV-301**, **SV-302**, **SV-303**, **SV-304** and **SV-305** are also available for additional purchase (optional)<sup>2</sup>. [Section 4.4](#) and [Section 4.5](#) define the **SV-301** and **SV-302** for the United States and Europe respectively. When purchased separately, SV wall plates are supplied without cables. For details regarding recommended TP cables, refer to [Section 9](#).



#### Advanced User Tip

The **SV-302** IR OUT port enables remote IR control (this requires the appropriate programming of the **SV-551**) over the source connected to it (a DVD player, a VHS player and so on).

---

<sup>1</sup> Plenum-rated for the SummitView™ US version; non-plenum for the SummitView™ Europe

<sup>2</sup> Download the user manual: SV-301, SV-302, SV-303, SV-304, SV-305 from <http://www.kramerelectronics.com>

#### 4.4 SV-301 and SV-302 (U.S.)

[Table 4](#) defines the front and rear views of the SV-301 and SV-302.

Table 4: Defining the SV-301 and SV-302 (U.S.)

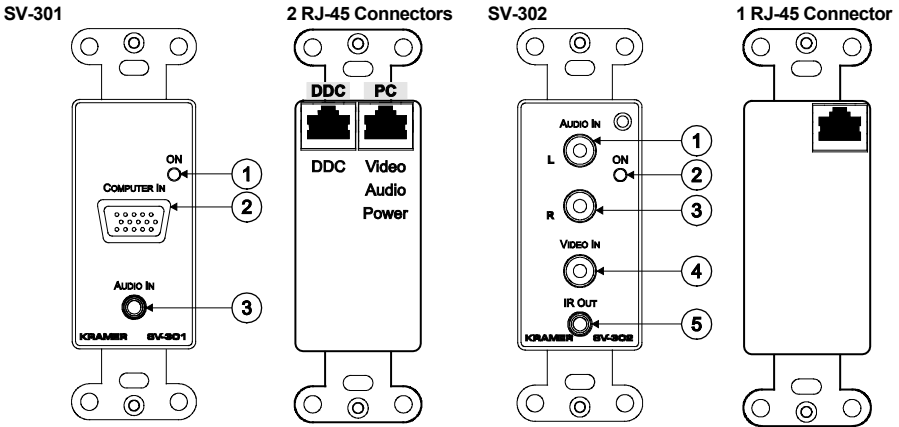

#	Feature	Function
1	ON LED	Lights red when receiving power (when no signal is detected); lights green when receiving a signal
2	COMPUTER IN 15-pin HD Connector	Connect to the computer graphics source
3	AUDIO IN 3.5mm Mini Plug	Connects to the audio source

#	Feature	Function
1	L AUDIO IN RCA Connector	Connect to the left analog audio source
2	ON LED	Lights red when receiving power (when no signal is detected); lights green when receiving a signal
3	R AUDIO IN RCA Connector	Connect to the right analog audio source
4	VIDEO IN RCA Connector	Connect to the composite video source
5	IR OUT 3.5mm Mini Plug	Connect to a machine via an IR Emitter



#### 4.5 SV-301 and SV-302 (England and Europe1)

The **SV-301** and **SV-302** are 1 Gang wall plate inserts. The **SV-301** has two terminal block connectors at the rear and the **SV-302** has one.

Table 5: Defining the SV-301 (England and Europe)<sup>2</sup>

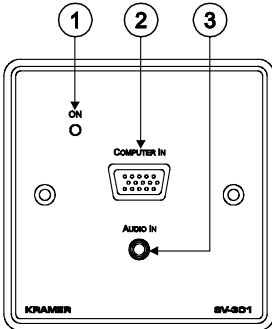

#	Feature	Function
1	ON LED	Lights red when receiving power (when no signal is detected); lights green when receiving a signal
2	COMPUTER IN 15-pin HD Connector	Connect to the computer graphics source
3	AUDIO IN 3.5mm Mini Plug	Connects to the audio source

Table 6: Defining the SV-302 (England and Europe)<sup>2</sup>

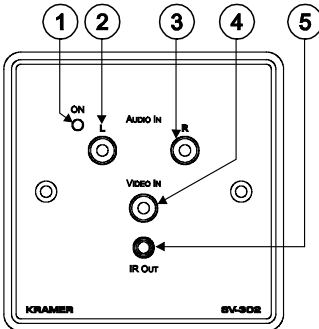

#	Feature	Function
1	ON LED	Lights red when receiving power (when no signal is detected); lights green when receiving a signal
2	L AUDIO IN RCA Connector	Connect to the left analog audio source
3	R AUDIO IN RCA Connector	Connect to the right analog audio source
4	VIDEO IN RCA Connector	Connect to the composite video source
5	IR OUT 3.5mm Mini Plug	Connect to a machine via an IR Emitter

1 The European versions are equipped with easy terminals, see [Section 8.2](#)

2 When mounting in Belgium and Germany, use the standard WP Adapter

## 4.6 Connecting the Wall Plates

The wall plates should be connected to the corresponding inputs on the **SV-551** using the supplied or optional STP cables<sup>1</sup> (see [Section 9](#)). The **SV-301** has two RJ-45 CAT 5 connectors (one for DDC and one for PC (Video/Audio/Power (US version))), as [Table 4](#) defines, and comes with two STP cables. The **SV-302** has one RJ-45 CAT 5 connector (U.S. version) and comes with one STP cable.

**To connect the SV-301, as the example in [Figure 3](#) illustrates (see also the separate color illustration referred to in [Section 5.6](#)):**

1. Connect the computer graphics source (for example, a laptop) to the Computer In 15-pin HD connector and to the unbalanced stereo Audio In 3.5mm mini jack on the front of the **SV-301**, for example, using a Kramer C-GMA/GMA cable (VGA HD15M +Audio jack to VGA HD15M +Audio jack)<sup>2</sup>.
2. On the rear of the **SV-301**, connect the RJ-45 CAT 5 connector marked:
  - “DDC” to the DDC 1 INPUT on the **SV-551**
  - “PC” to the PC 1 INPUT on the **SV-551**

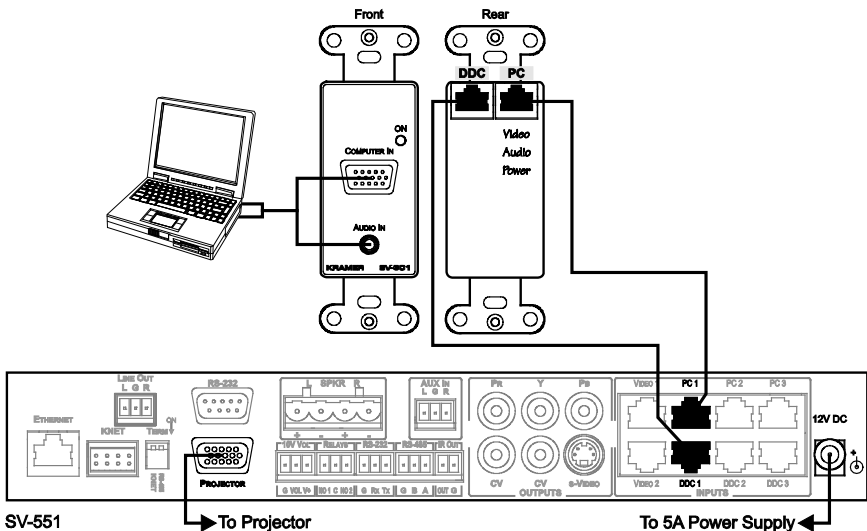

Figure 3: Connecting the SV-301 to the SV-551

1 There are two types of STP cable provided with SummitView™: CP-STP-50 (plenum-rated for the SummitView™ US) or C-STP-50 (non-plenum for the SummitView™ Europe). Other STP cables can also be used. However, when using longer STP cables, image quality can be impaired

2 Not supplied. The complete list of Kramer cables is on our Web site at <http://www.kramerelectronics.com>

To connect the **SV-302**, as the example in [Figure 4](#) illustrates, do the following:

1. On the front of the **SV-302**, connect the:
  - Composite video source (for example, a DVD player) to the yellow RCA connector, and to the unbalanced stereo audio RCA connectors
  - IR OUT 3.5mm mini plug via an IR Emitter<sup>1</sup> Control cable directly onto the IR sensor window of the controlled device (for example, a DVD player)
2. On the rear of the **SV-302**, connect the RJ-45 CAT 5 connector to the VIDEO 1 INPUT on the **SV-551**.

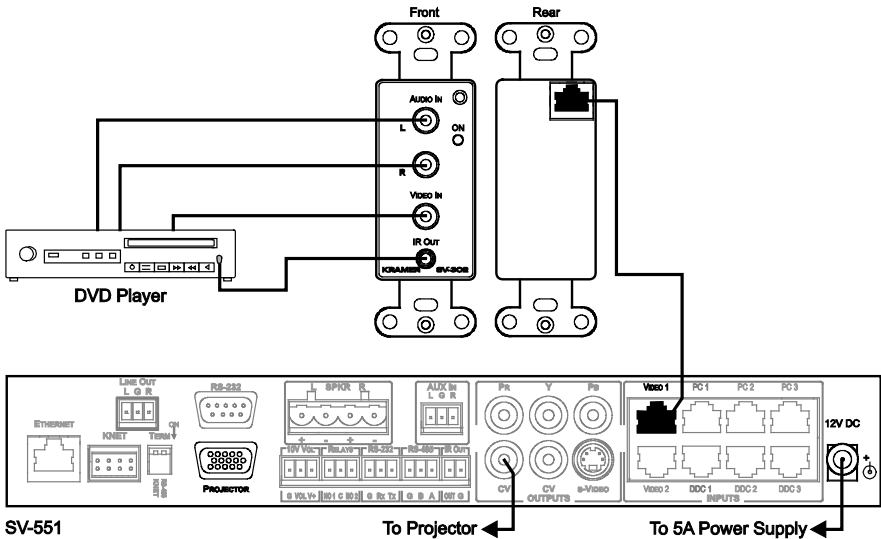

Figure 4: Connecting the SV-302 to the SV-551

In addition, you can connect the:

- **SV-303** (optional), which accepts an s-Video source on a 4p connector and unbalanced stereo audio on RCA connectors. The input signals are converted via an RJ-45 CAT 5 connector at the rear, and transmitted to the **SV-551**. The **SV-303** also has an IR out 3.5mm mini plug connector (connection to the **SV-551** is similar to the **SV-302**)
- **SV-304** (optional), which accepts a component video source on three

<sup>1</sup> The Emitter contains a small infrared LED housed in a miniature, mouse shaped, black plastic shell. It emits visible red light in addition to IR (infrared) control signals when activated by IR commands sent to it by IR receivers or other controllers. The Emitter Control Cable comes with a clear adhesive film included on the emitter housing for attachment to the IR window of the controlled component and pieces of double-sided clear adhesive tape included for replacement purposes

RCA connectors, as well as a digital audio (S/PDIF) input on an RCA connector. The input signals are converted via an RJ-45 CAT 5 connector at the rear and transmitted to the **SV-551**. The **SV-304** also has an IR out 3.5mm mini plug connector as an option using a second RJ-45 connector (connection to the **SV-551** is similar to the **SV-301**. The second DDC STP cable is only needed when using the IR OUT connector of the **SV-304**)

- **SV-305** (optional), which accepts a component video source on three RCA connectors and unbalanced stereo audio on RCA connectors. The input signals are converted via an RJ-45 CAT 5 connector at the rear and transmitted to the **SV-551**. The **SV-305** also has an IR out 3.5mm mini plug connector as an option using a second RJ-45 connector (connection to the **SV-551** is similar to the **SV-301**. The second DDC STP cable is only needed when using the IR OUT connector of the **SV-305**)

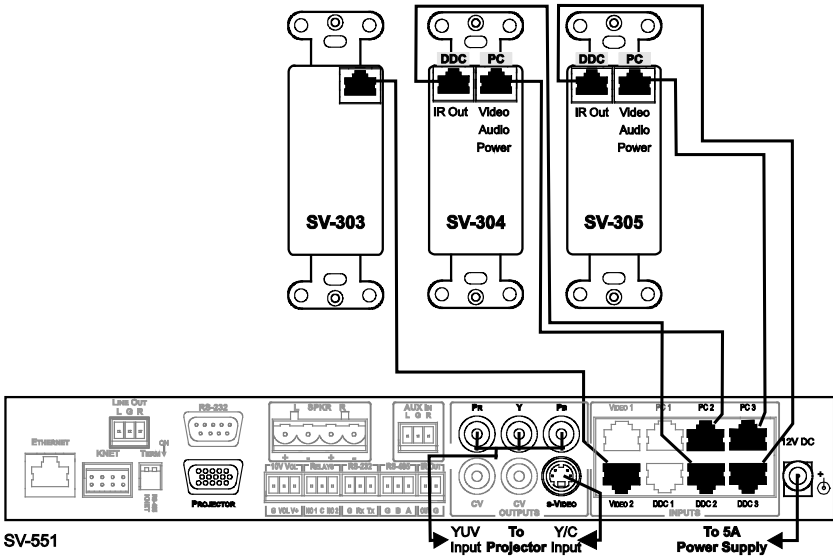

Figure 5: Connecting the SV-303/SV-304/SV-305 to the SV-551

## 4.7 Operating the SV-551 Remotely

The **SV-551** can be operated remotely via Ethernet over a LAN using the Kramer **Site-CTRL™** software. For details see the *Site-CTRL and Web Access Online User Guide*<sup>1</sup>.

<sup>1</sup> Available from <http://www.kramerelectronics.com>

## 5 Installing Optional Ceiling Speakers

The **SummitView™** kits can be ordered with optional ceiling speakers. Wall speakers and shelf speakers are also available for sale separately.

The type of speakers that you choose—for the ceiling, wall, shelf, or floor—will depend on your budget and preferences. The quantity and spacing of the speakers will depend on the height of the ceiling, the size of the room, the seating arrangement, and the acoustics in the room. For example, if the room is square shaped, we would recommend placing the speakers evenly to ensure an even sound coverage and ambient noise level compensation<sup>1</sup>.

This section explains how to install the closed-back ceiling speakers, that is:

- Choosing the best place to locate your speakers (see [Section 5.1](#))
- Cutting the ceiling tile (see [Section 5.2](#))
- Installing the speakers (see [Section 5.3](#))
- Painting the speakers (see [Section 5.4](#))
- Connecting several speakers (see [Section 5.5](#))

### 5.1 Choosing the Best Location

Ideally, locate the speakers above the main listening area. Before doing so, be sure that:

- The desired location is free of obstructions, such as electrical piping, AC ducts or water lines, etc.
- There is enough space behind the mounting surface for the speakers
- The rear side of the speaker is not blocked by wall studs or other objects

### 5.2 Cutting the Ceiling Tile<sup>3</sup>

If you are mounting the speakers onto a ceiling tile, remove the ceiling tiles where you plan to install the speakers. Use the template to trace and then cut out the speaker hole over an empty box.

To cut the ceiling tile, do the following:

1. Remove the circle in the supplied cardboard template<sup>2</sup>.
2. Mark the opening in the correct location by tracing the hole in the template.
3. Cut out the hole according to the template or with a circular cutter set to the appropriate cutout size<sup>3</sup>.

---

<sup>1</sup> In a small square-shaped room with four ceiling speakers each speaker would cover one-fourth of the listening area

<sup>2</sup> Keep this circular piece of cardboard for later use as a mask, as you may want to paint the speakers (see [Section 5.4](#))

<sup>3</sup> Initially, you can cut a smaller area inside the marked hole just to be sure that the space above the speakers is clear

4. Route the wiring from the SPKR terminal block connections of the **SV-551** (see [Table 2](#)) to the speakers' cutout holes, taking care not to place them next to electrical wires or at least at a distance of about two feet from an AC line.

### 5.3 Installing the Closed-back Ceiling Speakers

[Figure 6](#) and [Table 7](#) define the closed-back ceiling speakers.

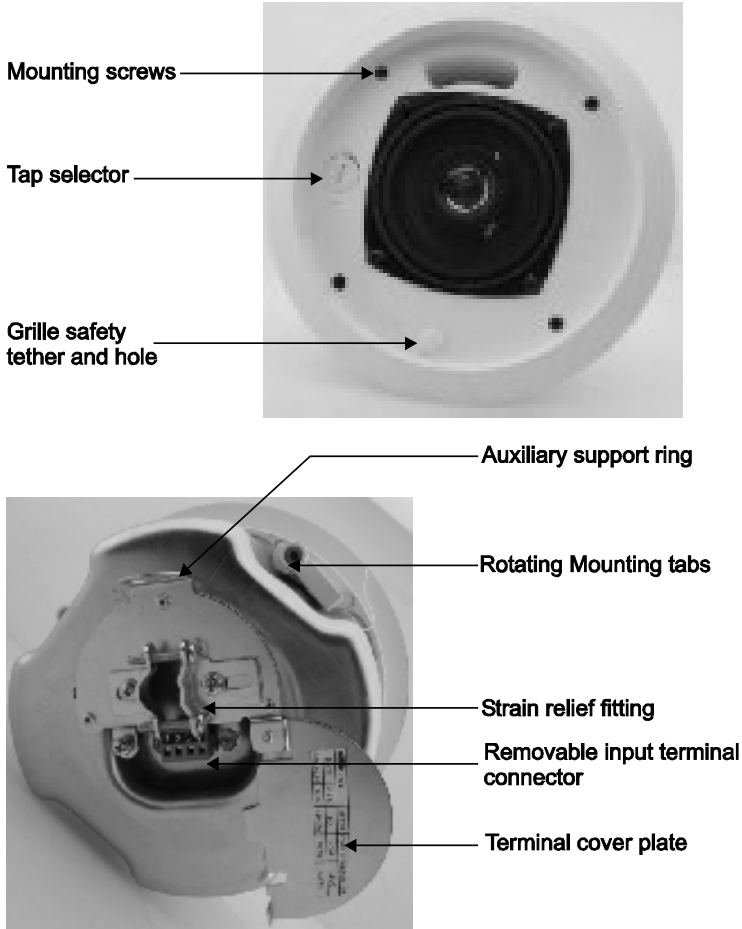

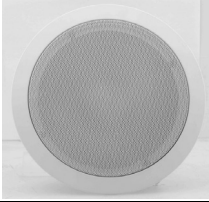





Figure 6: Closed-back Ceiling Speakers

## Installing Optional Ceiling Speakers

Table 7: Closed-back Ceiling Speakers Hardware Items

Description		
A pair of ceiling speakers (one shown) 	Two grilles (one shown) 	Cutout template 
Four support ring screws 	Two ceiling support rings (C-ring) (one shown) 	Two pairs of tile rails – one of a pair shown 

Each closed-back ceiling speaker is supported by a C-ring and two tile rails<sup>1</sup>. When mounting onto the ceiling tiles<sup>2</sup>, use both supports. When mounting onto a sheetrock ceiling, the C-ring alone is used to reinforce the ceiling material.

To install the closed-back ceiling speakers, do the following:

1. Place the C-ring over the hole cut in the ceiling tile (on the “ceiling” side). Place it around the hole so that the tabs are located in parallel to the tile edges (see [Figure 7](#)).

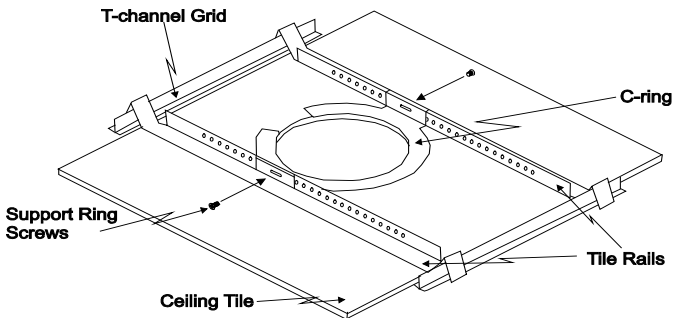

Figure 7: Installing the Closed-back Ceiling Speakers

<sup>1</sup> The tile rails prevent the speakers from falling if the tile itself comes out or falls apart, as their ends catch onto the T-grid

<sup>2</sup> Be sure that the tiles can support the speaker. Smaller sized tiles or fiberglass-type tiles cannot support the weight of the speakers. When this is the case, the speakers will need additional support

2. Place the tile rails on the tile and snap them into the two tabs on the C-ring. Align the rails so that the ends extend over the T-channel grid.
3. Insert a screw through each tab on the C-ring to secure the rails.
4. Connect the speaker wires to the appropriate connector terminals<sup>1</sup> and screw the hold-down screws on the connector until tight.

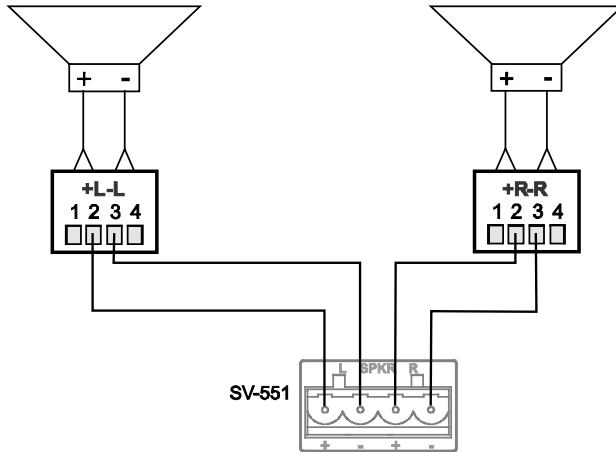

Figure 8: Wiring a Pair of Speakers to the SV-551

5. Plug the connector into the socket in the terminal cup of the speaker and tighten the screws (see [Figure 9](#)).
6. Loosen the horizontal screw and then the strain relief screws.
7. Run the wires through the opening in the fitting and plug the input connector into the terminal block connector of the speaker.

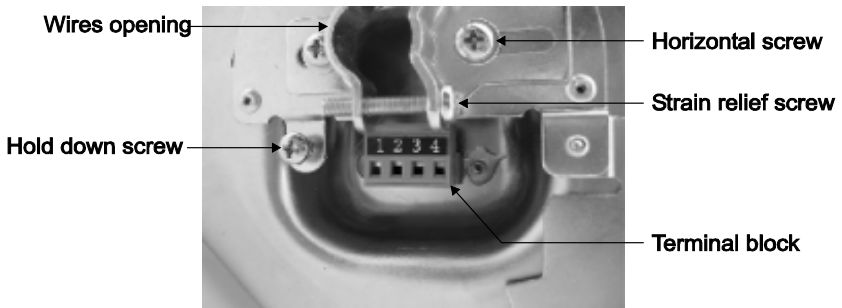
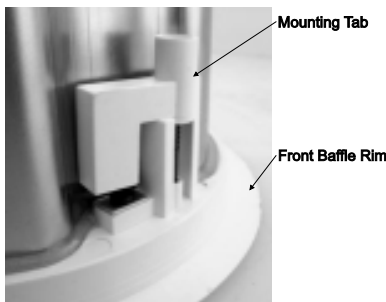

Figure 9: Plugging and Securing the Cables

<sup>1</sup> Pin 1 and Pin 2 are connected internally and are positive (+). Pin 3 and Pin 4 are connected internally and are negative (-)



8. Tighten the strain relief fitting, if plenum cable<sup>1</sup> is used:
  - Slide the wiring through the strain relief on the terminal cover plate
  - Hold the strain relief fitting tight around the cable
  - Tighten the strain relief screws first and then the horizontal screw<sup>2</sup>
9. Push the speaker into the ceiling hole until the front baffle rim is leveled with the ceiling.
10. Tighten the mounting tabs by turning the screw clockwise (see [Figure 10](#)). When tightening the mounting tabs, the tabs automatically turn outward, thus clamping the speaker to the wall from its rear side.  
**Note:** Do not over-tighten the screws. It may cause damage to both the speakers and the surface.



*Figure 10: Tighten the Mounting Tabs*

11. If required, you can further secure the speaker by connecting the speaker support ring to an independent secure anchor point.
12. Adjust each speaker to the appropriate tap setting before installing the grille<sup>3</sup>.
13. Install the grilles to the speakers:
  - Push the grille fastener into the hole in front of the baffle
  - Press the grille into place until the front of the grille is flush with the rim of the baffle
  - Check that the grille is securely seated<sup>4</sup>

---

1 If other types of cables are used, an alternate conduit fitting can be used by removing the existing fitting and replacing with an alternate one

2 In cases of an insulated speaker wire and plenum cable, it is often possible to provide acceptable strain relief force simply by tightening the strain relief screws onto the terminal cover plate

3 In addition to the 4 ohm setting, the power taps are 30W, 15W, 7.5W and 3.7W at both 70.7V and 100V

4 To remove the grille, insert two bent paper clips into the holes in the grille and carefully pull it down. Repeat this around the perimeter of the grille until it is completely removed

## 5.4 Painting the Speaker

You can paint the speakers before or after the speaker is installed.

When painting before installation:

- Clean the rim and grille with mineral spirits or other light solvent so as not to damage the surface
- Spray with color by holding the spray can at an angle of 45°  
**Note:** When spraying the grille, take care not to clog the holes in the grille as this will greatly reduce the sound quality of the speakers

When painting after installation:

- Use the circle that you cut out of the template as a paint mask
- After you finish painting, remove the paint mask

## 5.5 Connecting Several Speakers



### Advanced User Tip

For installations in large rooms, when several speakers are used for each audio channel, you can connect the speakers in two possible layouts:

- **Wiring in parallel:** connect the wire pair of the next speaker to PIN 2 and PIN 3. When one speaker is removed, subsequent speakers will remain connected
- **Daisy-chaining:** connect the wire pair of the next speaker to Pin 1 and Pin 4. When one speaker is removed, subsequent speakers will be disconnected

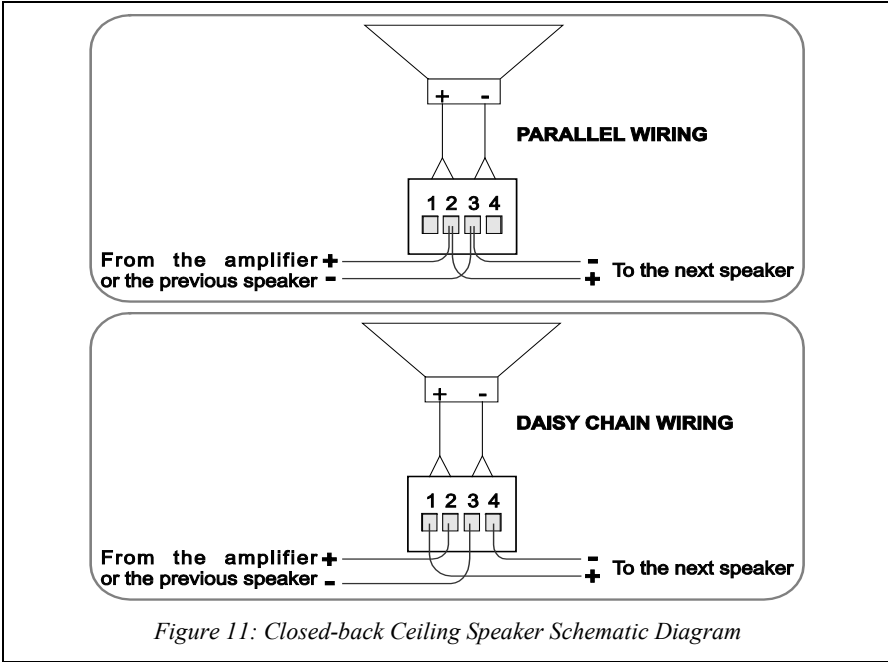

Figure 11: Closed-back Ceiling Speaker Schematic Diagram

### 5.5.1 Adjusting the Tap Selector



#### Advanced User Tip

Use the front mounted selector switch to select the required power level or impedance for your system.

We recommend that you select the power setting before installing the loudspeaker in the ceiling.

To select the required power level:

1. Remove the front grill from the loudspeaker.
2. Using a suitable flat blade screwdriver, select the required power rating or impedance for your installation by turning the selector until the required setting aligns with the arrow marks

Settings for both 70V and 100V line are provided. The 4 Ohm setting should only be used on balanced installations.

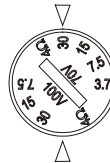

Figure 12: Adjust Tap Selector

## 5.6 Connecting the SV-551 SummitView™ Processor/Switcher

[Figure 13](#) shows how to connect the SV-551.

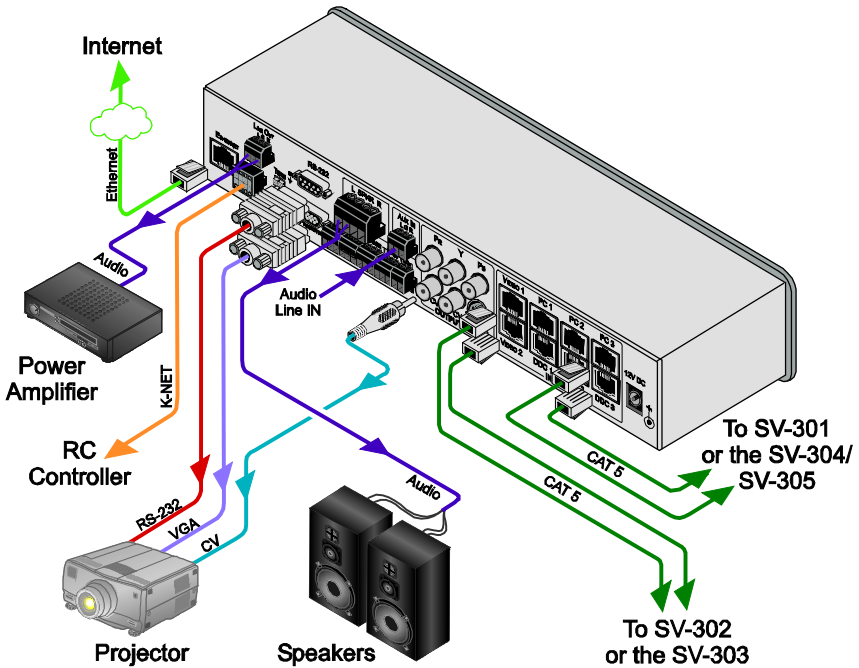

Figure 13: Connecting the SV-551 SummitView™ Processor/Switchers

[Figure 14](#) shows how to wire the K-Net connector.

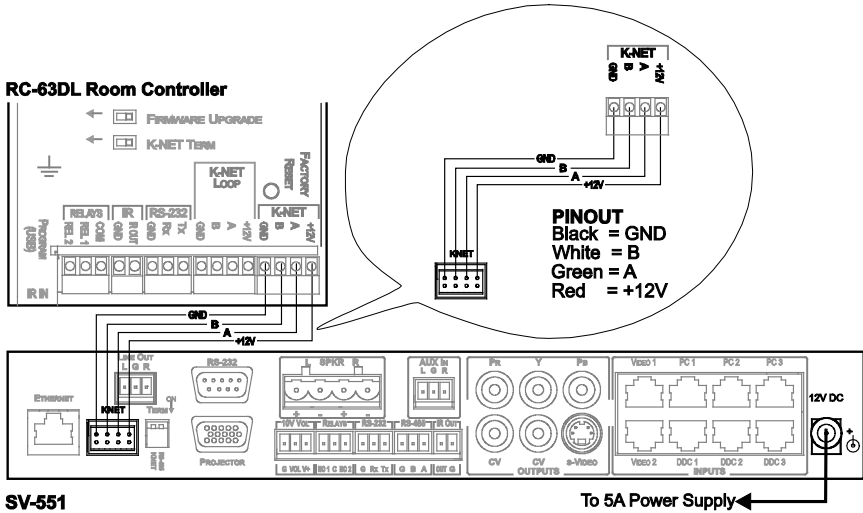

Figure 14: Wiring the K-Net Connector

## 5.7 Operating the SV-551 Remotely

The SV-551 can be operated remotely via Ethernet over a LAN using the Kramer Site-CTRL™ software. For details see the *Site-CTRL and Web Access Online User Guide*<sup>1</sup>.

<sup>1</sup> Available from <http://www.kramerelectronics.com>

## 5.8 Installing the SV-551 in a 19" RK-551 Rack (Option)

This section describes what to do before installing the SV-551 in a 19" rack (as opposed to inside the SV-1) and how to rack mount.

### Before Installing in a Rack

Before installing on a rack, be sure that the environment is within the recommended range:	
Operating temperature range	+5 to +45 Deg. Centigrade
Operating humidity range	10 to 90% RHL, non-condensing
Storage temperature range	-20 to +70 Deg. Centigrade
Storage humidity range	5 to 95% RHL, non-condensing



### CAUTION!!

When installing in a 19" rack, avoid hazards by taking care that:

- 1 It is located within the recommended environmental conditions, as the operating ambient temperature of a closed or multi unit rack assembly may exceed the room ambient temperature.
- 2 Once rack mounted, enough air will still flow around the machine.
- 3 The machine is placed straight in the correct horizontal position.
- 4 You do not overload the circuit(s). When connecting the machine to the supply circuit, overloading the circuits might have a detrimental effect on overcurrent protection and supply wiring. Refer to the appropriate nameplate ratings for information. For example, for fuse replacement, see the value printed on the product label.
- 5 The machine is earthed (grounded) in a reliable way and is connected only to an electricity socket with grounding. Pay particular attention to situations where electricity is supplied indirectly (when the power cord is not plugged directly into the socket in the wall), for example, when using an extension cable or a power strip, and that you use only the power cord that is supplied with the machine.

### How to Rack Mount

To rack-mount a machine (RK-551):

1. Attach the short ear bracket to the right side of the SV-551. To do so:
  - (i). Remove the screws from the right side of the SV-551.
  - (ii). Replace those screws through the short ear bracket.
2. Attach the long ear bracket with the power supply to the left side of the SV-551. To do so:
  - (i). Remove the screws from the left side of the SV-551.
  - (ii). Replace those screws through the long ear bracket.
  - (iii). Release the two screws of the power supply support, and slide the power supply under the power supply support, and tighten the screws.

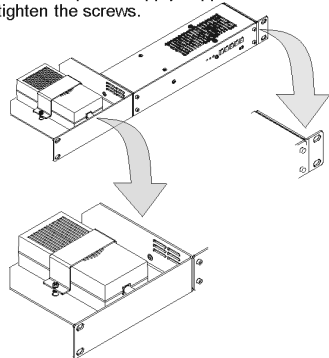

3. Place the ears of the machine against the rack rails, and insert the proper screws (not provided) through each of the four holes in the rack ears.

Note that:

- Detachable rack ears can be removed for desktop use or when installing in the SV-1
- Always mount the machine in the rack before you attach any cables or connect the machine to the power

## PART IV Further information

**PART IV includes further information.**

### 6 ADA Requirements

Attention must be paid to overhead clearances. Refer to the ADA Standards for Accessible Design (courtesy of the U.S. Department of Justice)<sup>1</sup>, and in particular, section 4-4", "Head Room":

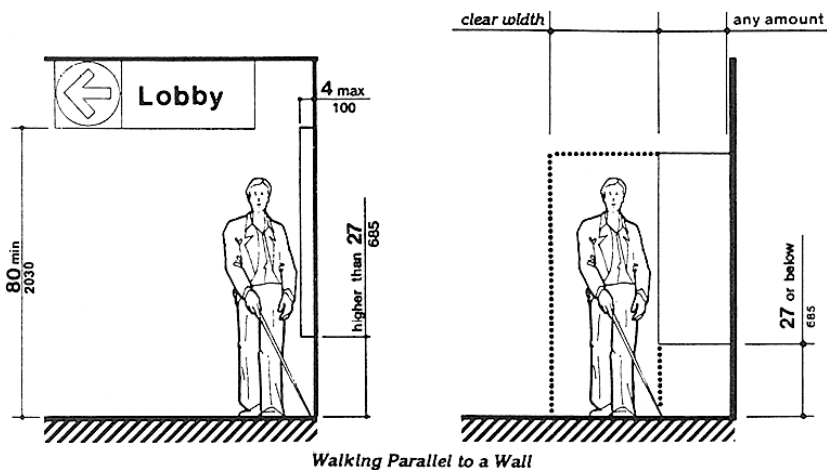
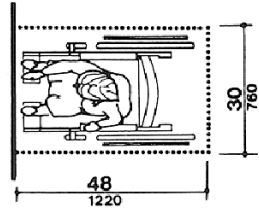
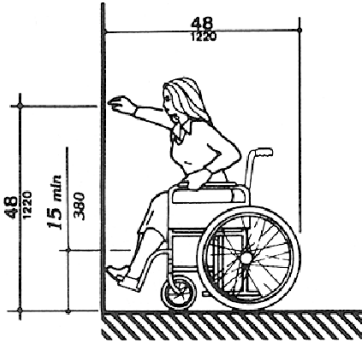
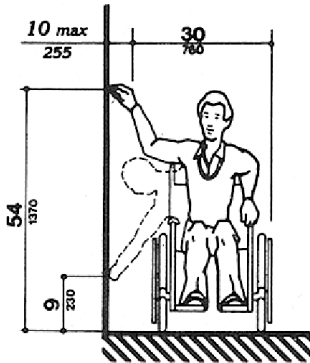

Figure 15: Overhead and Side Clearance Requirements

<sup>1</sup> You can download the file from their Web site at: <http://www.ada.gov/stdspdf.htm>



(a)  
High Forward Reach Limit



(b)  
High and Low Side Reach Limits

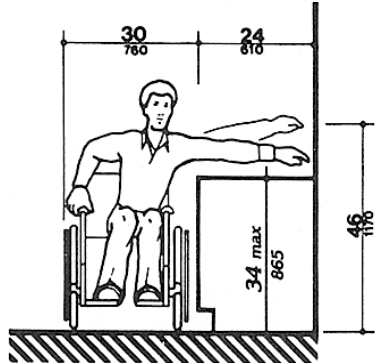

(c)  
Maximum Side Reach over Obstruction



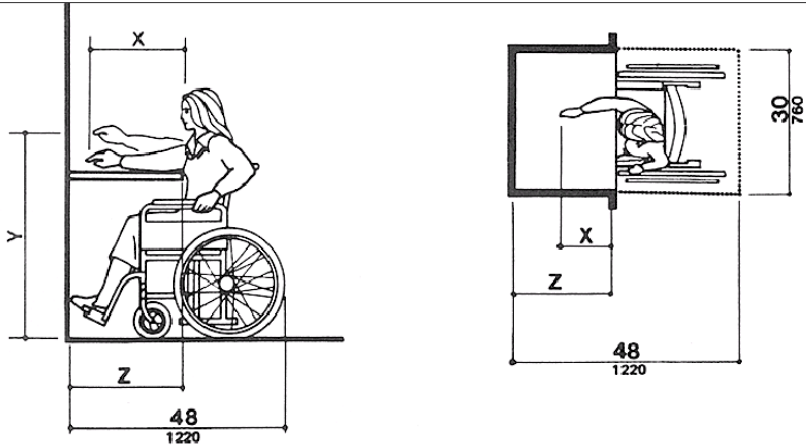

NOTE:  $x$  shall be  $\leq 25$  in (635 mm);  $z$  shall be  $\geq x$ . When  $x < 20$  in (510 mm), then  $y$  shall be 48 in (1220 mm) maximum. When  $x$  is 20 to 25 in (510 to 635 mm), then  $y$  shall be 44 in (1120 mm) maximum.

(b)  
Maximum Forward Reach over an Obstruction

Figure 16: High/Low Forward, Side, and Over Obstruction Reach Limit Requirements

## 7 Customizing the Controllers' Buttons and Labels

This section describes the backlit buttons and the button labels sheet.

### 7.1 Backlit Buttons

The **RC-63DL** backlit buttons<sup>1</sup> are available on plastic caps. To insert a label on a button—we recommend doing this before installing the controller, as it involves removing the face plate—unscrew the faceplate attachment screws, using a screwdriver, gently remove the transparent button cap with your fingers, and insert the label under the button cap. Replace the button cap with the label onto the button base.

<sup>1</sup> You can program the color of the button with flexible RGB values

## 7.2 Button Labels Sheet

[Figure 17](#) illustrates the sample "Button Labels" sheet:

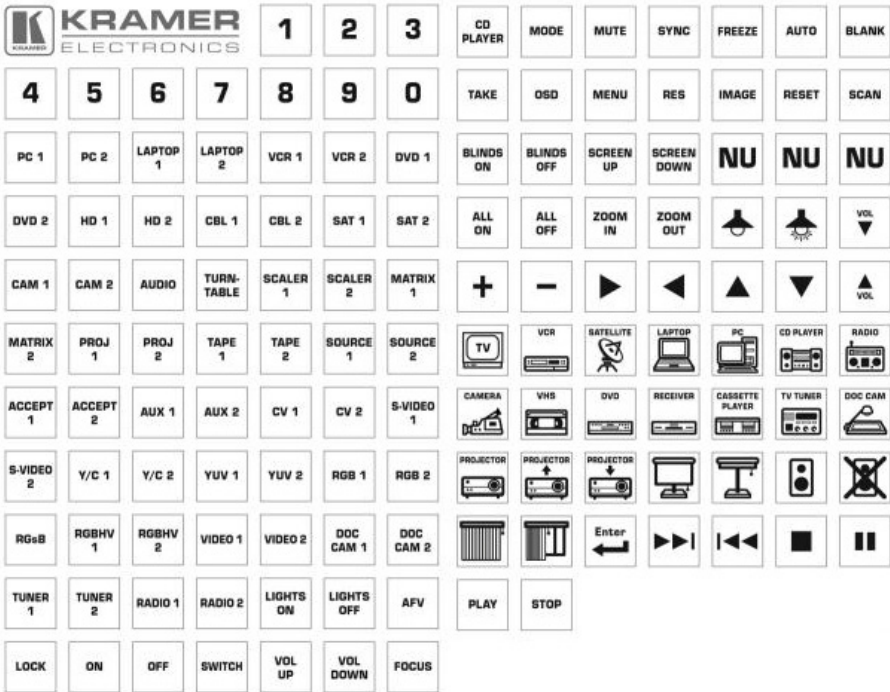

Figure 17: Sample "Button Labels" Sheet

## 8 Wiring the CAT 5 LINE IN/LINE OUT RJ-45 Connectors

STP cabling 50' (15.24m)<sup>1</sup> long is provided with the Kramer A/V SummitView™ Essentials Kit<sup>2</sup>. When required, longer STP cabling can be used when purchased for standalone wall plates but we recommend a maximum transmission range of up to 100' (30.48m). Exceeding the recommended distance may result in reduced image quality (see [Section 9](#)).

1 Plenum-rated for the SummitView™ US version; non-plenum for the SummitView™ Europe

2 Or should be purchased separately for a standalone machine, see [Table 10](#) for reference

This section describes how to connect the rear panel of the:

- US wall plate versions (see [Section 8.1](#))
- European wall plate versions (see [Section 8.2](#))

### 8.1 Wiring the CAT 5 RJ-45 Terminals (U.S.)

The U.S. versions of the SV wall plates are equipped with RJ-45 terminals. [Table 8](#) defines the STP CAT 5 pinout using a straight pin to pin cable with RJ-45 connectors.

Table 8: CAT 5 Pinout (U.S.)

EIA /TIA 568B	
PIN	Wire Color
1	Orange/White
2	Orange
3	Green/White
4	Blue
5	Blue/White
6	Green
7	Brown/White
8	Brown
<b>Pairing</b>	
Pair 1	4 and 5
Pair 2	1 and 2
Pair 3	3 and 6
Pair 4	7 and 8

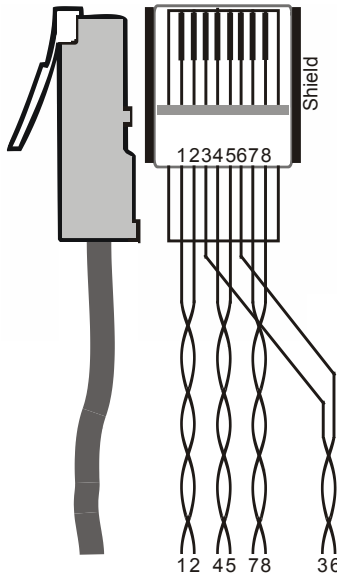

### 8.2 Wiring the Terminal Block Connector (England and Europe)

The European versions are equipped with an easy plug-in terminal for the CAT 5 cables. Use the color coded sticker on these terminals for proper connection of the CAT 5 cable.

[Table 9](#) defines the PINOUT of the terminal block connectors.

Table 9: Terminal block Connector Pinout (England and Europe)

**SV-301, SV-304, SV-305 Rear Panel PINOUT**

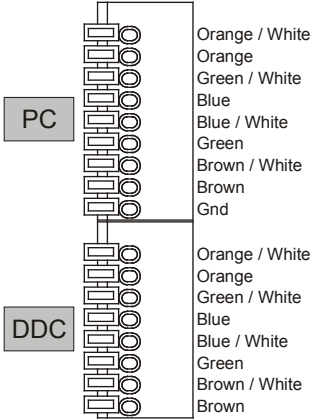

**SV-302, SV-303 Rear Panel PINOUT**

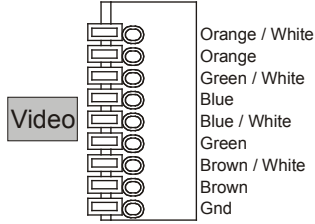

Notes:

- The “PC” section has 9 pins; the “DDC” section has 8 pins. Only use the connector clips to remove the wires, not when inserting them
- Each wire protrudes 9mm in length from the plastic casing so that it can be easily connected. To prevent the wires crossing, be sure that each wire is completely inserted
- With STP cable, the GND pin is used for shielding. For the DDC channel, shielding is not needed, but if desired, connect the GND pin of the PC

## 9 SummitView™ System Cables

[Table 10](#) defines the recommended cables for a SummitView™ installation.

Table 10: Cables included with the SV-551 SummitView™ Essentials Kit and SV-551 ALC

Cable Name	Description	Function	SV-551 ALC	Essentials Kit
Power Cord	AC mains cable	Connect the SV-551 to the AC mains supply	1	1
C-MGM/MGM-3	Molded Micro VGA to VGA cable 3ft (0.91m)	Connect the SV-551 to a display device	1	1
C-RVM/RVM-3	Molded RCA RG-59 video cable 3ft (0.91m)	Connect the SV-551 to a display device	1	1
C-SM/SM-3	s-Video cable 3ft (0.91m)	Connect the SV-551 to a display device	1	-
C-R3VM/R3VM-3	Component MINI high resolution cable 3ft (0.91m)	Connect the SV-551 to a display device	1	-

## SummitView™ System Cables

Cable Name	Description	Function	SV-551 ALC	Essentials Kit
C-D9M/D9F-3	RS-232 cable 3ft (0.91m)	Connect the SV-551 to a display device	1	1
AD-D9F/D9F	RS-232 Gender Changer	9-Pin D (F/F) gender changer	1	-
BCP-2S-25	Speaker cables	Connect the SV-551 to the speakers	-	1
C-UA/MUB-3	USB-A to Mini USB-B cable 3ft (0.91m)	Used to configure the SV-551 or the RC-63DL	1	1
CP-S5E45/S5E45-50 <sup>1</sup>	50ft (15.4m) CAT-5 cable, Plenum. Both sides with RJ-45 connectors	Connect the US wall plates to the SV-551	-	3 (2 for the SV-301, 1 for the SV-301)
C-S5E45/S5E45-50 <sup>2</sup>	50ft (15.4m) CAT-5 cable. Both sides with RJ-45 connectors	Connect US wall plates to the SV-551	-	3 (2 for the SV-301, 1 for the SV-301)
C-S5E45-50 <sup>3</sup>	50ft (15.4m) CAT-5 cable. One side with RJ-45 connector, one side unterminated	Connect EU wall plates to the SV-551	-	3 (2 for SV-301, 1 for SV-301)
BCP-KNET-50 <sup>4</sup>	50ft (15.4m), Plenum, balanced stereo audio/control cable	Connect RC unit to the SV-551	1	1
BC-KNET-50 <sup>5</sup>	50ft (15.4m), balanced stereo audio/control cable	Connect RC unit to the SV-551	1	1

The **SV-551** system EQ and LEVEL settings have been optimized for Kramer's dedicated, 15.2m, pre-cut CAT cable. We recommend using these cables for your SummitView installations whenever possible.

When making custom cables from Kramer bulk cabling, you should limit cable length to between 4m and 30m. Using shorter or longer cables may result in lower image quality.

The Kramer recommended cables should be used as they have been tested to work with the system. Using other cables may result in lower image quality and different supported cable lengths than specified.

<sup>1</sup> Supplied in Kits with US wall plates and in regions where Plenum cables are required

<sup>2</sup> Supplied in kits with US wall plates and in regions where plenum cables are not required

<sup>3</sup> Supplied in kits with EU wall plates

<sup>4</sup> Supplied in kits in regions where plenum cables are required

<sup>5</sup> Supplied in kits in regions where plenum cables are not required

Table 11: Additional Recommended Cables for the SV-551 SummitView™

Cable Part Number	Description	Function
CP-S5E45/S5E45-50	50ft (15.4m) CAT-5 cable, Plenum. Both sides with RJ-45 connectors	Connect US wall plates to the SV-551
C-S5E45/S5E45-50	50ft (15.4m) CAT-5 cable. Both sides with RJ-45 connectors	Connect US wall plates to the SV-551
C-S5E45-50	50ft (15.4m) CAT-5 cable. One side with RJ-45 connector, one side unterminated	Connect EU wall plates to the SV-551
BCP-STP-100M	Bulk, 100m, STP CAT-5, Plenum	Connect wall plates to the SV-551
BC-STP-50/100/300	Bulk, 50m or 100m or 300m, STP CAT-5	Connect wall plates to the SV-551

## 10 SummitView™ Cable Termination (Connector-to-Cable)

Table 10 defines the SummitView™ Cable Termination.

Table 12: SummitView™ Cable Termination

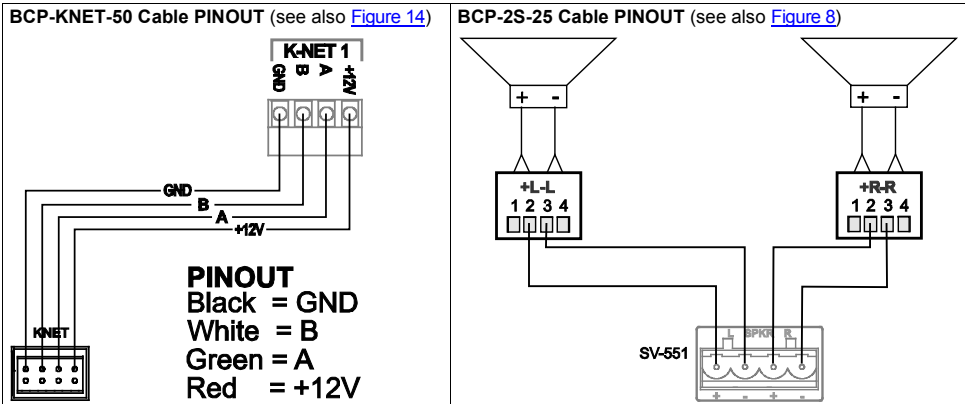
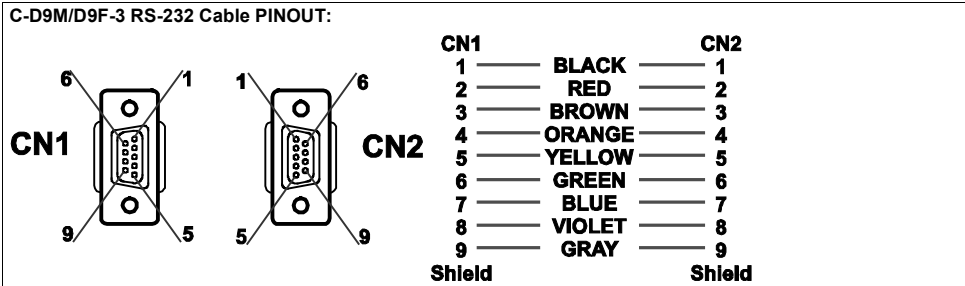

[Figure 18](#) defines the stickers affixed to the SummitView™ cables.

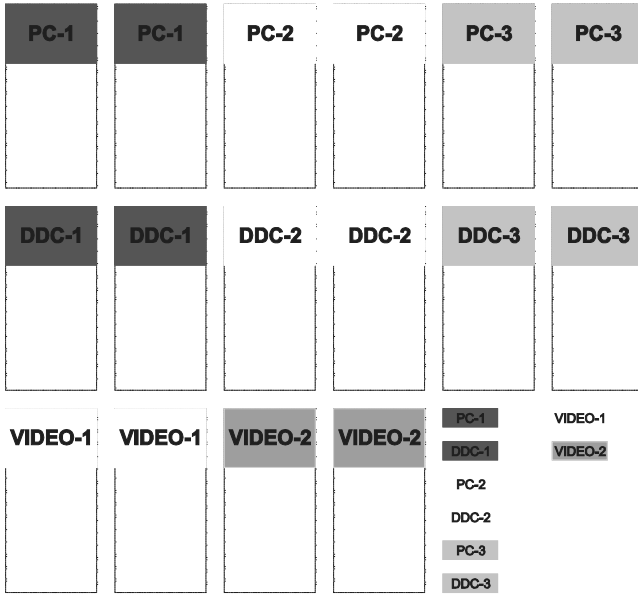

*Figure 18: Stickers affixed to Cables*

## 11 Technical Specifications

[Table 13](#) includes the technical specifications of the **SV-551**.

*Table 13: Technical Specifications<sup>1</sup> of the SV-551*

INPUTS:	1 AUX stereo on a 3-PIN terminal block; 2 video (CV and Y/C), 3 PC (XGA and Y, Pb, Pr), 3 DDC (external display) on RJ-45 connectors	
OUTPUTS:	1 SPKR (speaker) stereo on a 4-PIN terminal block; 1 Projector (XGA) on a15-PIN HD computer graphics video connector; 1 Y, Pb, Pr on 3 RCA connectors; 2 composite video on RCA connectors; 1 s-Video on a 4p connector, 3 DDC (bi-directional, inputs/outputs, as required) on RJ-45 connectors 10V Volume, 2 relays on terminal block connectors (36VAC or DC, 2A, 60VAC maximum on non-inductive load), RS-232, and RS-485 3-PIN terminal blocks; IR OUT 2-PIN terminal block	
MAX. OUTPUT LEVEL:	VIDEO: CV AND Y/C: 3.3Vpp; XGA and Y, Pb, Pr 1.4 to 2Vpp	AUDIO: 2 x 10W on 4Ω speaker
BANDWIDTH (-3dB):	VIDEO: CV AND Y/C: 82MHz to 86MHz; XGA and Y, Pb, Pr 130MHz to 140MHz	AUDIO: 20Hz to 20kHz
DIFF. GAIN:	0.2% to 0.5%	
DIFF. PHASE:	0.2 Deg.	
K-FACTOR:	0.1% to 0.4%	
S/N RATIO:	VIDEO: 62dB to 68dB	AUDIO: 60dB to 72dB
CONTROLS:	IR, RS-232, RS-485, Ethernet, K-NET	
COUPLING:	VIDEO: DC	AUDIO: Input: AC; Output: DC
AUDIO THD + NOISE:	0.06% to 0.7%	
AUDIO 2nd HARMONIC:	0.02% to 0.2%	
POWER SOURCE:	12V 5A desktop power adapter	
DIMENSIONS:	27.78cm x 7.65cm x 4.36cm (10.94" x 3.01" 1.72", W, D, H)	
WEIGHT:	0.65kg (1.43lbs) approx.	
ACCESSORIES:	See <a href="#">Table 10</a>	
OPTIONS:	Power supply, a pair of detachable rack-ears and shelf, <b>RK-551</b> (for installing on a 19" rack as opposed to mounting inside the <b>SV-1</b> )	

<sup>1</sup> Specifications are subject to change without notice



---

## LIMITED WARRANTY

Kramer Electronics (hereafter *Kramer*) warrants this product free from defects in material and workmanship under the following terms.

### HOW LONG IS THE WARRANTY

Labor and parts are warranted for seven years from the date of the first customer purchase.

### WHO IS PROTECTED?

Only the first purchase customer may enforce this warranty.

### WHAT IS COVERED AND WHAT IS NOT COVERED

Except as below, this warranty covers all defects in material or workmanship in this product. The following are not covered by the warranty:

1. Any product which is not distributed by Kramer, or which is not purchased from an authorized Kramer dealer. If you are uncertain as to whether a dealer is authorized, please contact Kramer at one of the agents listed in the Web site [www.kramerelectronics.com](http://www.kramerelectronics.com).
2. Any product, on which the serial number has been defaced, modified or removed, or on which the WARRANTY VOID IF TAMPERED sticker has been torn, reattached, removed or otherwise interfered with.
3. Damage, deterioration or malfunction resulting from:
  - i) Accident, misuse, abuse, neglect, fire, water, lightning or other acts of nature
  - ii) Product modification, or failure to follow instructions supplied with the product
  - iii) Repair or attempted repair by anyone not authorized by Kramer
  - iv) Any shipment of the product (claims must be presented to the carrier)
  - v) Removal or installation of the product
  - vi) Any other cause, which does not relate to a product defect
  - vii) Cartons, equipment enclosures, cables or accessories used in conjunction with the product

### WHAT WE WILL PAY FOR AND WHAT WE WILL NOT PAY FOR

We will pay labor and material expenses for covered items. We will not pay for the following:

1. Removal or installations charges.
2. Costs of initial technical adjustments (set-up), including adjustment of user controls or programming. These costs are the responsibility of the Kramer dealer from whom the product was purchased.
3. Shipping charges.

### HOW YOU CAN GET WARRANTY SERVICE

1. To obtain service on you product, you must take or ship it prepaid to any authorized Kramer service center.
2. Whenever warranty service is required, the original dated invoice (or a copy) must be presented as proof of warranty coverage, and should be included in any shipment of the product. Please also include in any mailing a contact name, company, address, and a description of the problem(s).
3. For the name of the nearest Kramer authorized service center, consult your authorized dealer.

### LIMITATION OF IMPLIED WARRANTIES

All implied warranties, including warranties of merchantability and fitness for a particular purpose, are limited in duration to the length of this warranty.

### EXCLUSION OF DAMAGES

The liability of Kramer for any effective products is limited to the repair or replacement of the product at our option. Kramer shall not be liable for:

1. Damage to other property caused by defects in this product, damages based upon inconvenience, loss of use of the product, loss of time, commercial loss; or.
2. Any other damages, whether incidental, consequential or otherwise. Some countries may not allow limitations on how long an implied warranty lasts and/or do not allow the exclusion or limitation of incidental or consequential damages, so the above limitations and exclusions may not apply to you.

This warranty gives you specific legal rights, and you may also have other rights, which vary from place to place.

**NOTE:** All products returned to Kramer for service must have prior approval. This may be obtained from your dealer.

This equipment has been tested to determine compliance with the requirements of:

- EN-50081: "Electromagnetic compatibility (EMC);  
generic emission standard.  
Part 1: Residential, commercial and light industry"
- EN-50082: "Electromagnetic compatibility (EMC) generic immunity standard.  
Part 1: Residential, commercial and light industry environment".
- CFR-47: FCC\* Rules and Regulations:  
Part 15: "Radio frequency devices  
Subpart B Unintentional radiators"

### CAUTION!

- Servicing the machines can only be done by an authorized Kramer technician. Any user who makes changes or modifications to the unit without the expressed approval of the manufacturer will void user authority to operate the equipment.
- Use the supplied DC power supply to feed power to the machine.
- Please use recommended interconnection cables to connect the machine to other components.  
\* FCC and CE approved using STP cable (for twisted pair products)

## 12 Detachable SummitView™ Essentials Kit Check List

Table 14: SummitView™ Essentials Kit Check List

PART	DESCRIPTION	#	<input checked="" type="checkbox"/>
<b>SV-551</b>	<b>SummitView™ Processor/Switcher</b>	1	
<b>C-D9M/D9F-3</b>	<b>RS-232 cable 3' (0.91m)</b>	1	
<b>BCP-2S-25</b>	<b>Speakers cable</b>	2	
<b>BCP-KNET-50</b>	<b>Balanced Audio/Control cable 50' (15.24m)</b>	1	
<b>C-UA/MUB-3</b>	<b>USB A to mini USB B cable 3' (0.91m)</b>	1	
<b>P.S 12V/5A</b>	<b>US and EU models</b>	1	
<b>POWER CORD</b>	<b>According to country</b>	1	
<b>CD-ROM</b>	<b>RC Configuration software</b>	1	
<b>SCREWDRIVER</b>	<b>For installation</b>	1	
<b>RC-63DL</b>	<b>Room Controller</b>	1	
<b>C-UA/MUB-3</b>	<b>USB A to mini USB B cable 3' (0.91m)</b>	1	
<b>CD-ROM</b>	<b>RC Configuration software</b>	1	
<b>SCREWDRIVER</b>	<b>For installation</b>	1	
<b>SV-301</b>	<b>Wall Plate (Computer Graphics Video + Audio)</b>	1	
<b>C(P)-STP-50<sup>1</sup></b>	<b>STP cable 50' (15.24m)</b>	2	
<b>C-MGM/MGM-3</b>	<b>Molded Micro VGA to VGA cable 3' (0.91m)</b>	1	
<b>SV-302</b>	<b>Wall Plate (Composite Video + Audio)</b>	1	
<b>C(P)-STP-50<sup>1</sup></b>	<b>STP cable 50' (15.24m)</b>	1	
<b>C-RVM/RVM-3</b>	<b>Molded RCA RG-59 video cable 3' (0.91m)</b>	1	
<b>SPK-CC444</b>	<b>Ceiling Speakers</b>	1	

<sup>1</sup> CP-STP-50 is plenum-rated for the SummitView™ US; C-STP-50 is non-plenum for the SummitView™ Europe



---

**For the latest information on our products and a list of Kramer distributors, visit our Web site [www.kramerelectronics.com](http://www.kramerelectronics.com) where updates to this user manual may be found.**

**We welcome your questions, comments and feedback.**



**Caution**

**Safety Warning:**

Disconnect the unit from the power supply before opening/servicing.



---

**Kramer Electronics, Ltd.**

Web site: [www.kramerelectronics.com](http://www.kramerelectronics.com)

E-mail: [info@kramereel.com](mailto:info@kramereel.com)

P/N: 2900-000336 REV 5