

VM9424



What's in the Box

- VM9424 Head Unit
- Left and Right Double DIN Mounting Brackets
- Double DIN Half Sleeve Install Bracket
- Remote Control with Battery
- Two Custom Cosmetic Trim Rings
- Parking Brake Wire
- Hardware Bag
- Speaker Output Harness
- Power Input Harness
- 2 x Accessory Harness
- Installation Guide

Tools and Supplies

- You will need these tools and supplies to install your VM9424:
- Torx type, flat-head and Philips screwdrivers
 - Wire cutters and strippers
 - Tools to remove existing radio (screw driver, socket wrench set or other tools)
 - Electrical tape
 - Crimping tool
 - Volt meter/test light
 - Crimp connections
 - 18 gauge wire for power connections
 - 16 – 18 gauge speaker wire

WARNING! Never install this unit where operation and viewing could interfere with safe driving conditions.

Optional Equipment

- **BTM10:** Allows you to connect to a Bluetooth enabled cell phone or other device.
- **Rear Camera**

Disconnecting the Battery

To prevent a short circuit, be sure to turn off the ignition and remove the negative (-) battery cable prior to installation.

NOTE: If the VM9424 is to be installed in a car equipped with an on-board drive or navigation computer, do not disconnect the battery cable. If the cable is disconnected, the computer memory may be lost. Under these conditions, use extra caution during installation to avoid causing a short circuit.

Replacing the Fuse

When replacing the fuse, use a new 15A replacement fuse. Using a fuse with an improper rating could damage the unit and cause a fire.

ISO-DIN Installation

This unit is designed to fit into a 2.0 DIN dashboard opening, found in many imported cars. The unit has threaded holes in the chassis side panels which may be used with the original factory mounting brackets of some Toyota, Nissan, Mitsubishi, Isuzu, Hyundai and Honda vehicles to mount the radio to the dashboard. Please consult with your local car stereo specialty shop for assistance on this type of installation.

- 1** Remove the existing factory radio from the dashboard or center console mounting. Save all hardware and brackets as they will be used to mount the new radio.
- 2** Remove the factory mounting brackets and hardware from the existing radio and attach them to the new radio.
CAUTION: Do not exceed M5 X 6MM screw size. Longer screws may damage components inside the chassis.
- 3** Place the radio in front of the dashboard opening so the wiring can be brought through the mounting sleeve. Follow the wiring diagram carefully and make certain all connections are secure and insulated with wire nuts or electrical tape. After completing the wiring connections, plug the ISO connectors into the mating sockets on the rear of the chassis. Turn the unit on to confirm operation (vehicle ignition switch must be "on"). If the unit does not operate, re-check all wiring until the problem is corrected.
- 4** Mount the new radio assembly to the dashboard or center console using the reverse procedure in step 1.

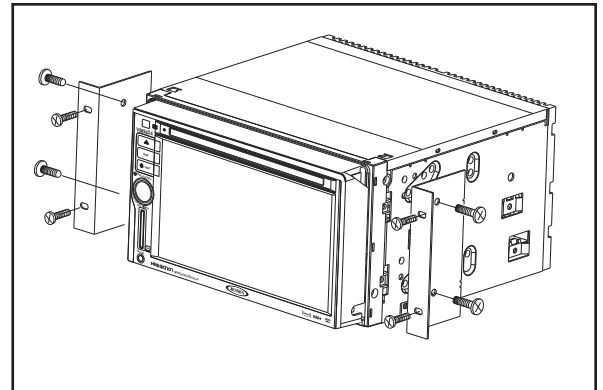

CAUTION! Be careful not to damage the car wiring.

NOTE: It is the end-users responsibility to install and operate this unit in a manner in accordance with local, state and federal laws. The PARKING BRAKE wire MUST BE CONNECTED as directed in the manual.

CAUTION: Do not block the cooling fan exit. If blocked, the unit may overheat and become damaged.

Installation Using Half-Sleeve

- 1** Install half-sleeve in the dashboard.
 - a. Install adapter if necessary (optional).
 - b. Install half-sleeve into adapter or dashboard (use only the supplied screws). Do not force the sleeve into the opening or cause it to bend or bow.
WARNING! Only connect the unit to a 12-volt power supply with proper grounding.
 - c. Locate the series of bend-tabs along the top, bottom and sides of the mounting sleeve. With the sleeve fully inserted into the dashboard opening, bend as many of the tabs outward as necessary so that the sleeve is firmly secured to the dashboard.
- 2** Use the M5 x 6 screws (provided) to install the mounting brackets to each side of the radio using the holes indicated in the diagram. **DO NOT USE OTHER SCREWS.**
- 3** Place the radio in front of the dashboard opening so the wiring can be brought through the mounting sleeve.
- 4** Complete wiring as illustrated in the wiring diagram. Once the wiring is complete, reconnect the battery negative terminal. If there is no ACC available, connect the ACC lead to the power supply with a switch.
CAUTION! Be careful not to damage the car wiring.
- 5** After completing the wiring connections, turn the unit on to confirm operation (ignition switch must be on). If unit does not operate, recheck all wiring until problem is corrected. Once proper operation is achieved, turn off the ignition switch and proceed with final mounting of the chassis.
 - a. Connect wiring adapter to existing wiring harness.
 - b. Connect antenna lead.
 - c. Carefully slide the radio into the half-sleeve, making sure it is right-side-up. Use the supplied screws to attach the radio to the half sleeve.

Using the Cosmetic Trim Ring

Two cosmetic trim rings are packaged with the head unit for installation flexibility. This unit will fit into most import dashes with little or no modification to the dash board/cavity. Some US domestic vehicle dashes will accept a Double-DIN chassis, but there is usually a small gap between the radio and dash piece after installation is complete. In this case, use the appropriate trim ring to conceal any gaps that may be present.

NOTE: For proper operation of the CD/DVD player, the chassis must be mounted within 30° of horizontal. Make sure the unit is mounted within this limitation.

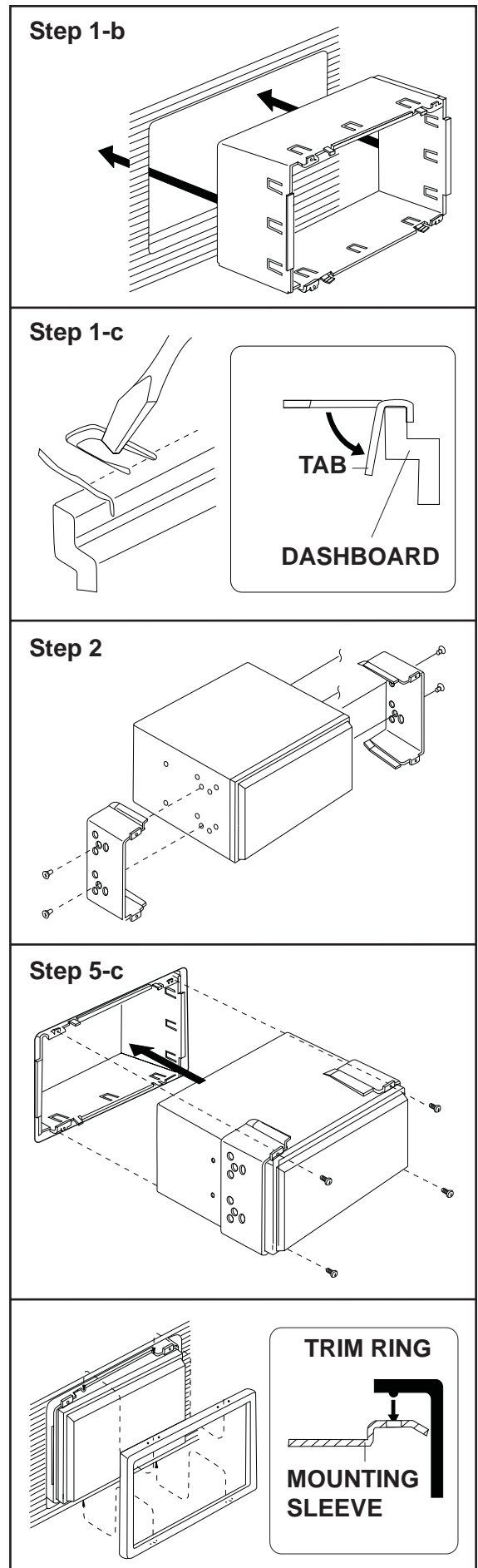

Wiring Diagram

IMPORTANT: Incorrect wiring connections can damage the unit. Follow the wiring instructions carefully, or have the installation handled by an experienced technician.

Need Help? For technical assistance, call the Jensen customer support line at 1-800-323-4815.

