

Please read and save these instructions. Read carefully before attempting to assemble, install, operate or maintain the product described. Protect yourself and others by observing all safety information. Failure to comply with instructions could result in personal injury and/or property damage! Retain instructions for future reference.

Dayton® Propane Construction Heater

Description

Dayton Model 4E769B heater is a 35,000 BTU/Hr construction heater. This heater uses propane gas for combustion and electricity to run the motor. It is primarily intended for temporary heating of buildings under construction, alteration, or repair. This heater should only be used indoors but never in occupied dwellings.

Unpacking

1. Remove all packing items applied to heater for shipment. Keep plastic cover caps (attached to inlet connector and hose/regulator assembly) for storage.
2. Remove all items from carton.
3. Check all items for shipping damage. If heater is damaged, promptly inform dealer where you bought heater.



Figure 1 – Model 4E769B



▲ GENERAL HAZARD WARNING

Failure to comply with the precautions and instructions provided with this heater can result in death, serious bodily injury, and property loss or damage from hazards of fire, explosion, burn, asphyxiation, carbon monoxide poisoning, and/or electrical shock. Only persons who can understand and follow instructions should use or service this heater.

If you need assistance or heater information such as an instructions manual, labels, etc. contact the manufacturer.

▲ WARNING Fire, burn, inhalation, and explosion hazard. Keep solid combustibles such as building materials, paper or cardboard, a safe distance away from the heater as recommended by the instructions. Never use the heater in spaces which do or may contain volatile or airborne combustibles, or products such as gasoline, solvents, paint thinner, dust particles, or unknown chemicals.

▲ WARNING Not for home or recreational vehicle use.

Heater is designed and approved for use as a construction heater under ANSI Z83.7. The primary purpose of construction heaters is to provide temporary heating of buildings under construction, alteration or repair, and to provide temporary emergency heat. Properly used, the heater provides safe economical heating. Products of combustion are vented into the area being heated.

We cannot foresee every use which may be made of our heaters. Check with your local fire safety authority if you have questions about heater use.

Other standards govern the use of fuel gases and heat producing products for specific uses. Local authorities can advise you about these.

Dayton® Propane Construction Heater

General Safety Information

Make certain you read and understand all warnings. Keep these instructions for reference. They are your guide to safe and proper operation of this heater.

Safety information appears throughout these instructions. Pay close attention to them. Below are definitions for the safety information listed throughout this manual.

⚠ DANGER Under this heading, installation, operating, and maintenance procedures or practices will be found that, if not carefully followed, WILL result in IMMEDIATE serious personal injury or death.

⚠ WARNING Under this heading, installation, operating, and maintenance procedures or practices will be found that, if not carefully followed, COULD result in severe personal injury or death.

⚠ CAUTION Under this heading, installation, operating, and maintenance procedures or practices will be found that, if not carefully followed, MAY result in minor personal injury, product, or property damage.

IMPORTANT: Not every possible circumstance that might involve a hazard can be anticipated. The warnings in this manual and on tags or decals affixed to the unit are therefore not all-inclusive. If a procedure, work method, or operating technique not specifically recommended by Dayton is used, you must make sure it is safe for you and others. You should also ensure that equipment will not be damaged or made unsafe by the operating or maintenance method you choose.

⚠ DANGER *Carbon monoxide poisoning may lead to death! Some people are more affected by carbon monoxide than others. Early signs of carbon monoxide poisoning resemble the flu, with headaches, dizziness, and/or nausea. If you have these signs, the heater may not be working properly or the areas may not be sufficiently ventilated. Get fresh air at once! Have heater serviced.*

Propane Gas: *Propane gas is odorless. An odor-making agent is added to propane gas. The odor helps you detect a propane gas leak. However, the odor added to propane gas can fade. Propane gas may be present even though no odor exists.*

⚠ WARNING • *Install and use heater with care. Follow all local ordinances and codes. In the absence of local ordinances and codes, refer to the Standard for Storage and Handling of Liquefied Petroleum Gas ANSI/FPA 58. This instructs on the safe storage and handling of propane gases.-*

- *Use only the hose and factory preset regulator provided with the heater.*
- *Use only propane gas set up for vapor withdrawal.*
- *Provide adequate ventilation. Before using heater, provide at least a six-square-foot opening of fresh, outside air. This heater produces carbon monoxide, which is listed by the State of California as a reproductive toxin under Proposition 65.*
- *For indoor use only. Do not use heater outdoors.*
- *Do not use heater in occupied dwellings or in living or sleeping quarters.*
- *Do not use heater in a basement or below ground level. Propane gas is heavier than air. If a leak occurs, propane gas will sink to the lowest*

possible level and may accumulate to explosive concentrations.

- *Keep appliance area clear and free from combustible materials, gasoline, paint thinner, and other flammable vapors and liquids. Dust is combustible. Do not use heater in areas with high dust content.*
- *Minimum heater clearances from combustibles:
Outlet: 6 Ft. Sides: 2 Ft.
Top: 6 Ft. Rear: 2 Ft.*
- *Keep heater at least six feet from propane tank(s). Do not point heater at propane tank(s) within 20 feet.*
- *Keep propane tank(s) below 100° F.*
- *Check heater for damage before each use. Do not use a damaged heater.*
- *Inspect hose before each use of heater. If highly worn or cut, replace before using heater. Use the replacement hose assembly specified in this manual.*
- *Locate heater on stable and level surface if heater is hot or running.*
- *Never block air inlet (rear) or air outlet (front) of heater.*
- *Keep heater away from strong drafts, water spray, rain, or dripping water.*
- *Keep children and animals away from heater.*
- *Never move, handle, or service a hot, operating, or plugged-in heater. Severe burns may result. You must wait 15 minutes after turning heater off.*
- *Never attach duct work to heater.*
- *Do not alter heater. Keep heater in its original state.*
- *Do not use heater if altered.*
- *Turn off propane supply and unplug heater when not in use.*
- *Use only original replacement parts. This heater must use design-specific parts. Do not substitute or use generic parts. Improper replacement parts could cause serious or fatal injuries.*

Model 4E769B

General Safety Information (Continued)

- *The electrical connections and grounding of the heater shall follow the National Electric Code, ANSI/NFPA 70.*
- *Use only the electrical voltage and frequency specified on model plate.*
- *Electrical grounding instructions — This appliance is equipped with a three-prong (grounding) plug for your protection against shock hazard and should be plugged directly into a properly grounded three-prong receptacle.*
- *Use only a three-prong, grounded extension cord.*

Specifications

ELECTRICAL SPECIFICATIONS

Electrical Input	Amperage
120 Volt/60Hertz	2

GENERAL SPECIFICATIONS

Output Rating BTU/Hr	Fuel	Fuel Consumption	Size L x W x H (Inches)	Regulator Outlet Pressure	Weight (pounds)
35,000	Only Propane Vapor	.38 Gallons/Hour 1.6 Pounds/Hour	18.5 x 7.7 x 12.8	11" WC	14.5 (Heater) 16 (Shipping)

GENERAL SPECIFICATIONS (Cont.)

Manifold Pressure	Hot Air Output (CFM Approx)	Ignition	Supply Pressure To Regulator	Temperature Range For Operating Heater	Motor
10.8" WC	175	Manual Piezo	10 psi Minimum (for purposes of input adjustment) Tank Pressure or 200 psi Maximum	-20° F to 85° F*	2735 RPM

(*) When running heater in temperatures above 85° F, high internal temperatures may cause thermal limit device to shut down heater. Minimum ambient operating temperature: -20°F (-28°C).

Dayton® Propane Construction Heater

Product Identification

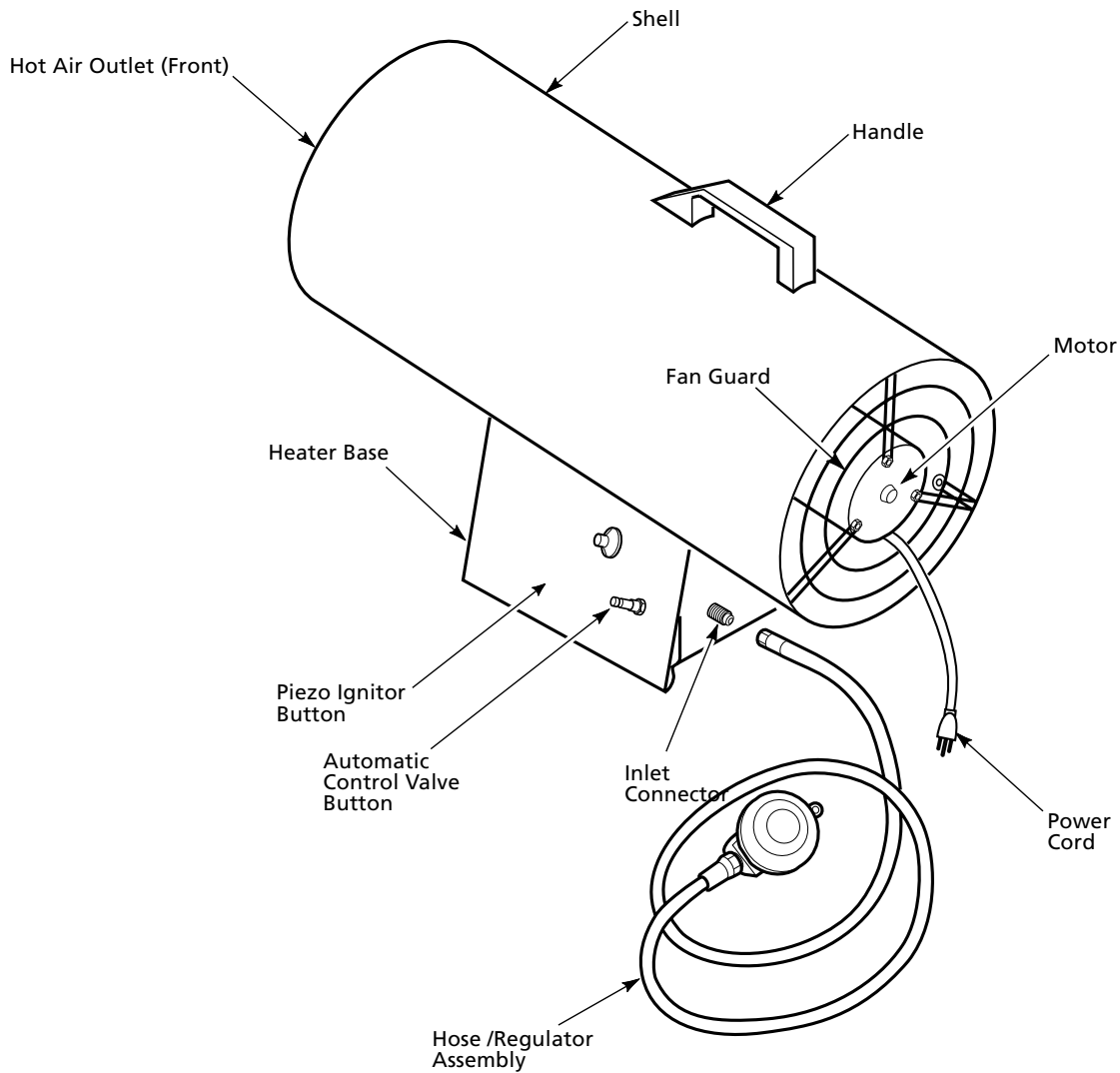

Figure 2 - Model 4E769B

Model 4E769B

Theory of Operation

THE FUEL SYSTEM

The hose/regulator assembly attaches to the propane gas supply. This provides fuel to the heater.

THE AIR SYSTEM

The motor turns the fan. The fan pushes air into and around the combustion chamber. This air is heated and provides a stream of clean, hot air.

THE IGNITION SYSTEM

The piezo ignitor lights the burner.

THE AUTOMATIC CONTROL SYSTEM

This system causes the heater to shut down if the flame goes out.

Propane Supply

Propane gas and propane tank(s) must be provided by the customer.

Use this heater only with a propane vapor withdrawal supply system. See Chapter 5 of the *Standard for Storage and Handling of Liquefied Petroleum Gas, ANSI/NFPA 58*. Your local library or fire department will have this booklet.

The amount of propane gas ready for use from propane tanks varies. Two factors decide this amount:

1. The amount of propane gas in tank(s)
2. The temperature of tank(s)

This heater is designed to operate with a minimum 20-pound propane tank. You may need two or more tanks or one larger tank in colder weather. Use a 100-pound tank for longer operation or in very cold weather. Less gas is vaporized at lower temperatures. Your local propane gas dealer will help you select the proper supply system. The minimum surrounding air temperature rating for each heater is -20°F (-29°C).

Average Temperature (°F) at Tank Location	Number of Tanks (100 pound)
40°	1
32°	1
20°	1
10°	1
0°	1
-10°	2
-20°	2

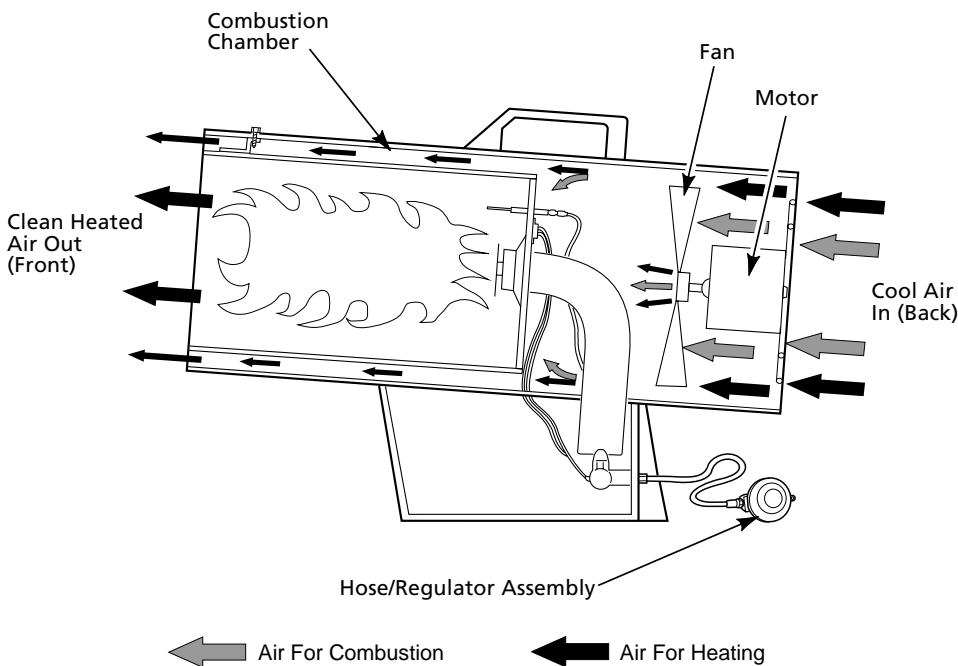

Figure 3 - Cross Section Operational View

Dayton® Propane Construction Heater

Installation

▲WARNING Review and understand the warnings in the General Safety Information Section. They are needed to safely operate this heater. Follow all local codes when using this heater.

▲WARNING Test all gas piping and connections for leaks after installation or servicing. Never use an open flame to check for a leak. Apply a mixture of liquid soap and water to all joints. Bubbles forming show a leak. Correct all leaks at once.

1. Provide propane supply system (See Propane Supply, page 5).
2. Connect POL fitting on hose/regulator assembly to propane tank(s). Turn POL fitting counterclockwise into threads on tank. Tighten firmly using 7/8" wrench.

IMPORTANT: Position regulator so that hose leaving the regulator is in a horizontal position (See Figure 4). This places the regulator vent in the proper position to protect it from the weather.

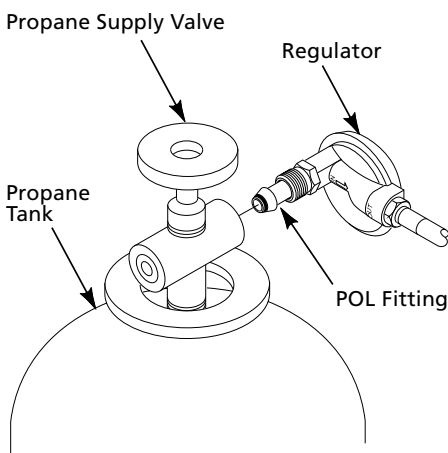

Figure 4 - Regulator Position

3. Connect hose to inlet connector. Tighten firmly using a wrench.

IMPORTANT: Use extra hose or piping if needed. Install extra hose or piping between hose/regulator assembly and propane tank. You must use the regulator supplied with heater.

4. Open propane supply valve on propane tank(s) slowly.

NOTE: If not opened slowly, excess-flow check valve on propane tank will stop gas flow. If this happens, close propane supply valve and open again slowly.

5. Check all connections for leaks.

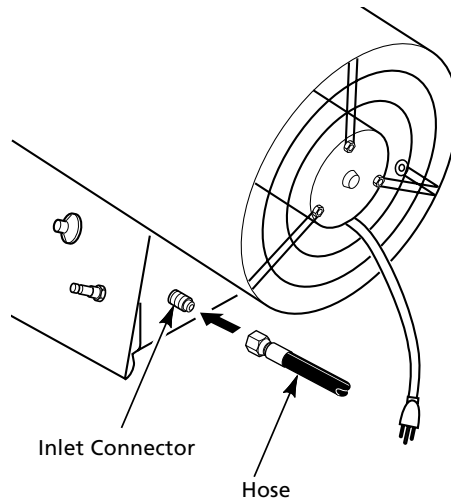

Figure 5 - Hose and Inlet Connector

▲WARNING Never use an open flame to check for a leak. Apply a mixture of liquid soap and water to all joints. Bubbles forming show a leak. Correct all leaks at once.

6. Close propane supply valve.

Ventilation

▲WARNING Provide at least a one-square-foot opening of fresh, outside air while running heater. If proper fresh, outside air ventilation is not provided, carbon monoxide poisoning can occur. Provide proper fresh, outside air ventilation before running heater.

Operation

▲WARNING Review and understand the warnings in the General Safety Information section. They are needed to safely operate this heater. Follow all local codes when using this heater.

TO START HEATER

1. Follow all installation, ventilation, and safety information.
2. Locate heater on stable and level surface. Make sure strong drafts do not blow into front or rear of heater.
3. Plug power cord of heater into a three-prong, grounded extension cord. Extension cord must be at least six feet long. Extension cord must be UL listed.

EXTENSION CORD WIRE SIZE REQUIREMENTS

- Up to 50 feet long, use 18 AWG rated cord.
 51 to 100 feet long, use 16 AWG rated cord.
 101 to 200 feet long, use 14 AWG rated cord.
4. Plug extension cord into a 120 volt/60 hertz, three-hole, grounded outlet. Motor will start. Fan will turn, forcing air out front of heater.
 5. Open propane supply valve on propane tank(s) slowly.

Model 4E769B

Operation (Continued)

NOTE: If not opened slowly, excess-flow check valve on propane tank will stop gas flow. If this happens, close propane supply valve and open again slowly.

▲WARNING *Be sure motor and fan are running before pushing in automatic control valve button. Flames could flash outside heater if motor and fan are not running.*

6. Push in and hold automatic control valve button (See Figure 6). Push piezo ignitor button (See Figure 6). You may need to push piezo ignitor button 3-8 times until the burner lights. When burner lights, keep automatic control valve button pushed in. Release button after 30 seconds.

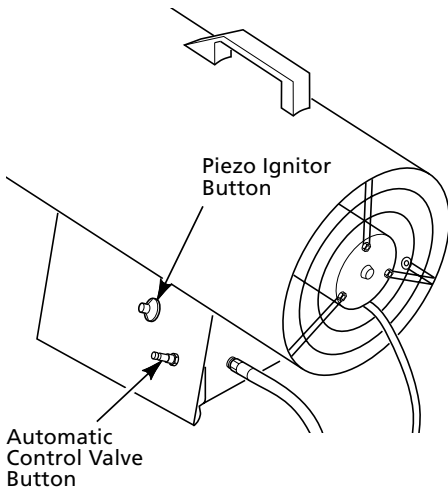

Figure 6 - Automatic Control Valve Button and Piezo Ignitor Button

NOTE: If heater fails to ignite, hose may have air in it. If so, keep automatic control valve button pressed and wait 20 seconds. Release automatic control valve button and wait 20 seconds for unburned fuel to exit heater. Repeat step 6.

NOTE: If heater is unplugged or power outage occurs while heater is running, the thermal limit device will stop fuel flow. A few seconds occur before the thermal limit device activates. During this short time, flames may appear outside the heater. This is normal. The flames will go out when thermal limit device activates.

TO STOP HEATER

1. Tightly close propane supply valve on propane tank(s).
2. Wait a few seconds. Heater will burn gas left in supply hose.
3. Unplug heater.

TO RESTART HEATER

1. Wait five minutes after stopping heater.
2. Repeat steps under *To Start Heater*, page 6.

Storage

▲CAUTION *Disconnect heater from propane supply tank(s).*

1. Store propane tank(s) in safe manner. See Chapter 5 of *Standard for Storage and Handling of Liquefied Petroleum Gases, ANSI/NFPA 58*. Follow all local codes. Always store propane tanks outdoors.
2. Place plastic cover caps over brass fittings on inlet connector and hose/regulator assembly.
3. Store in dry, clean, and safe place. Do not store hose/regulator assembly inside heater combustion chamber.
4. When taking heater out of storage, always check inside of heater. Insects and small animals may place foreign objects in heater. Remove motor and other internal parts if needed to remove foreign objects (See *Service Procedures*, page 8).

Maintenance

▲WARNING *Never attempt to service heater while it is connected to propane supply, operating, or hot. Severe burns and electrical shock can occur.*

▲WARNING *Keep heater clear and free from combustible materials, gasoline, and other flammable vapors and liquids.*

▲WARNING *Do not block the flow of combustion or ventilation air.*

1. Keep heater clean. Clean heater annually or as needed to remove dust and debris. If heater is dirty or dusty, clean heater with a damp cloth. Use household cleaners on difficult spots.
2. Inspect heater before each use. Check connections for leaks. Apply mixture of liquid soap and water to connections. Bubbles forming show a leak. Correct all leaks at once.
3. Inspect hose/regulator assembly before each use. If hose is worn or cut, replace.
4. Have heater inspected yearly by a qualified service agency.
5. Keep inside of heater free from combustible and foreign objects. Remove motor and other internal parts if need to clean inside of heater (See *Service Procedures*, page 8).
6. Clean fan blades each season or as needed (See *Fan*, page 8).

Dayton® Propane Construction Heater

Maintenance (Continued) SERVICE PROCEDURES

⚠ WARNING *Never attempt to service heater while it is connected to propane supply, operating, or hot. Severe burns and electrical shock can occur.*

ELECTRICAL SYSTEM

The entire electrical system for this heater is contained within the motor. If any part of the electrical system is damaged, you must replace motor.

MOTOR REPLACEMENT

1. Remove three screws that attach fan guard to heater shell.
2. Remove motor and fan guard from heater shell (See Figure 7).

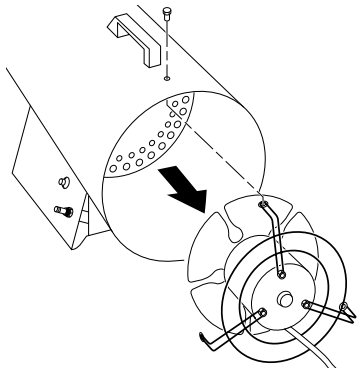

Figure 7 - Removing Motor and Fan Guard from Heater

3. Use pliers to remove the fan nut from front of motor shaft (See Figure 8).

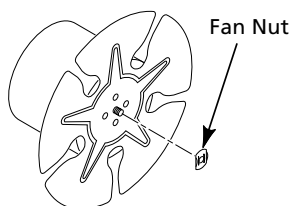

Figure 8 - Removing Fan Nut from Motor Shaft

4. Remove fan. Be careful not to damage the fan blade pitch.
5. Remove three nuts that attach fan guard to motor using nut-driver. Remove fan guard from motor (See Figure 9).

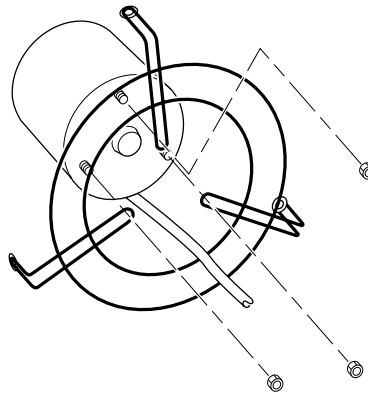

Figure 9 - Removing or Attaching Fan Guard from Motor

6. Discard old motor.
7. Attach fan guard to new motor using three nuts. When attaching fan guard to motor, you must position power cord as shown in Figure 9. Tighten nuts firmly.
8. Place fan onto motor shaft of new motor.

IMPORTANT: When placing fan onto motor shaft, make sure part number stamped on fan is facing motor. Attach fan nut to end of motor shaft. Tighten fan nut firmly.

9. Place motor and fan guard into rear of heater shell. Make sure power cord is properly located (See Figure 10).
10. Insert three screws through heater shell and into fan guard. Tighten screws firmly.

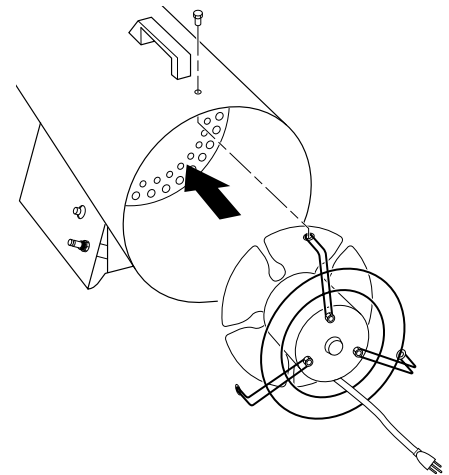

Figure 10 - Replacing Motor and Fan Guard into Heater

FAN

1. Remove three screws that attach fan guard to heater shell.
2. Remove motor and fan guard from heater shell (See Figure 11).

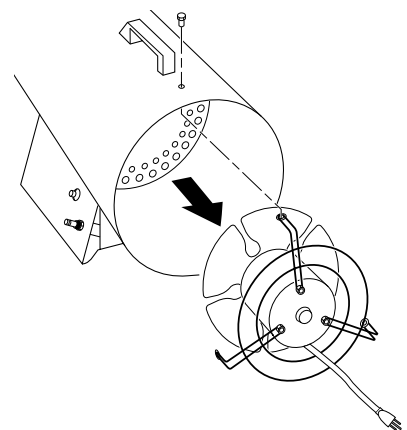

Figure 11 - Removing Motor and Fan Guard from Heater

Model 4E769B

Maintenance (Continued)

- Use pliers to remove the fan nut from front of motor shaft (See Figure 12).

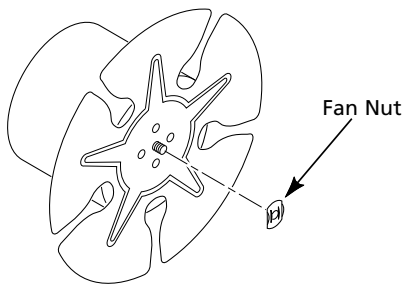

Figure 12 - Removing Fan Nut From Motor Shaft

- If replacing fan, remove old fan and discard. Go to step 7 below.
- If cleaning fan, remove fan. Be careful not to damage the fan blade pitch.
- Clean fan using soft cloth moistened with kerosene or solvent.
- Dry fan thoroughly.
- Place fan onto motor shaft.

IMPORTANT: When placing fan onto motor shaft, make sure part number stamped on fan is facing motor.

- Attach fan nut to end of motor shaft. Tighten fan nut firmly.

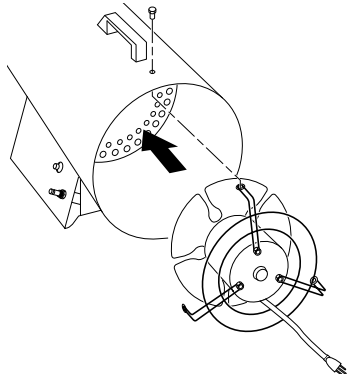

Figure 13 - Replacing Motor and Fan Guard into Heater

- Place motor and fan guard into rear of heater shell. Make sure power cord is properly located (See Figure 13).
- Insert three screws through heater shell and into fan guard. Tighten screws firmly.

IGNITOR

- Remove motor and fan guard from heater (See *Motor*, page 8, steps 1 and 2).
- Remove black ignitor wire from piezo ignitor. Access ignitor wire through underside of heater base (See Figure 14). Push wire up through bushing in heater shell.

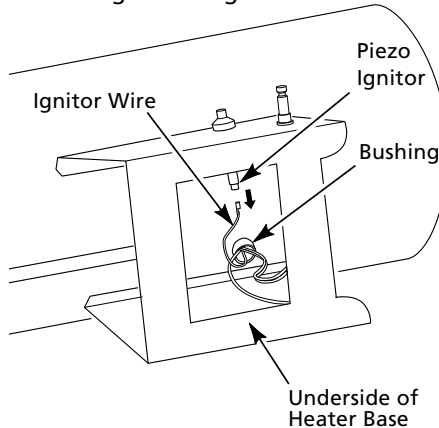

Figure 14 - Removing Ignitor Wire from Piezo Ignitor

- Remove ignitor mounting screw from rear head using nut-driver or standard screwdriver (See Figure 15).
- Remove ignitor from rear head.
- Install new ignitor. Attach ignitor to rear head with ignitor mounting screw.
- Run ignitor wire from new ignitor through bushing in heater shell. Attach ignitor wire to piezo ignitor.

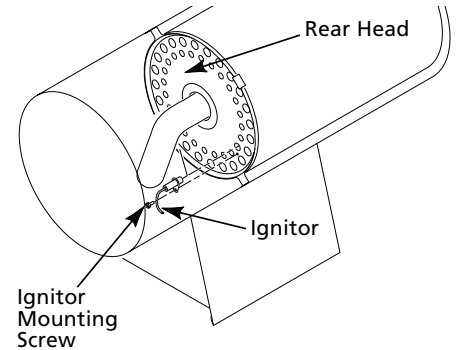

Figure 15 - Removing Ignitor Mounting Screw and Ignitor

- Set gap between ignitor electrode and target plate to .17" (See Figure 16).

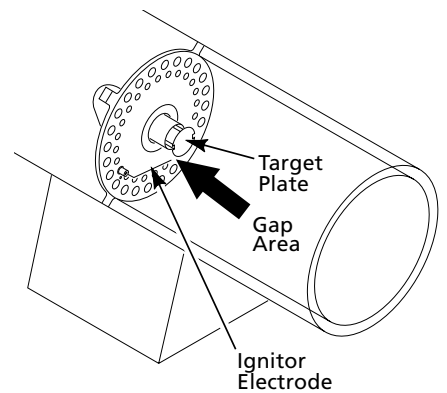

Figure 16 - Clearance Between Ignitor Electrode and Target Plate

- Test for spark.

⚠ WARNING *Make sure heater is disconnected from propane supply. Heater could ignite causing severe burns.*

- Push piezo ignitor button and watch for spark between ignitor electrode and target plate.
- Place motor and fan guard into rear of heater shell (See *Motor*, page 8, steps 9 and 10).

For Replacement Parts, call 1-800-323-0620

24 hours a day - 365 days a year

Please provide following information:

- Model number
- Serial number (if any)
- Part description and number as shown in parts list

Address parts correspondence to:

Grainger Parts
 P.O. Box 3074
 Northbrook, IL 60065-3074 U.S.A.

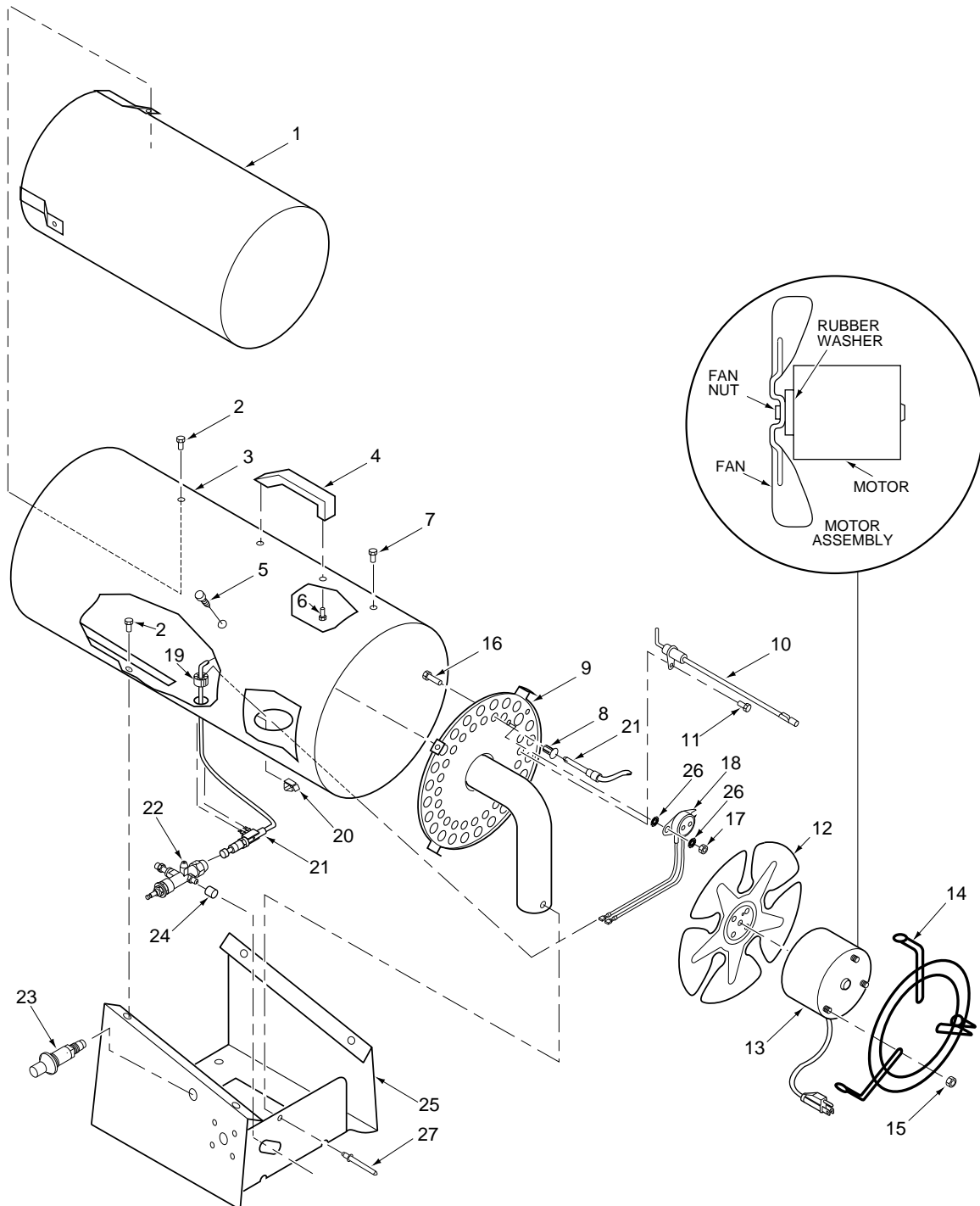

Figure 17 - Replacement Parts Illustration

Replacement Parts List

Reference Number	Description	Part No.	Quantity
1	Inner shell (Combustion Chamber)	099568-01	1
2	#10-16 x 3/8" Hex tap screw	*M11084-26	7
3	Outer shell	099599-01AZ	1
4	Handle	M51104-01	1
5	Hex tap shoulder screw	099230-01	4
6	#10-16 x 3/4" Hex tap screw	*M11084-29	2
7	#12-14 x 1/2" Hex tap screw	*M11084-3	3
8	Thermocouple clip	099237-01	1
9	Burner assembly	099727-01	1
10	Electrode ignitor	099539-01	1
11	#8-18 x 3/8" Hex tap screw	*M11084-38	1
12	Fan	099537-01	1
13	Motor assembly (Includes rubber washer and fan nut)	099521-01	1
14	Fan guard	099540-01	1
15	Captive washer nut	097384-02	3
16	#4-40 x 1/2" Hex screw	*097968-05	2
17	#4-40 Hex nut	*NPC-00C	2
18	Thermal switch kit	101732-02	1
19	Universal bushing	097776-01	1
20	Wire clip	099542-01	1
21	Thermocouple	099538-01	1
22	Valve/orifice assembly	099728-01	1
23	Piezo ignitor	102445-01	1
24	Sleeve cap	078978-03	1
25	Base	103892-01	1
26	#4 Lock washer	*100397-01	4
27	1/8" Steel rivet	*099202-02	1
Δ	Tradename decal	100163-03	1
Δ	Tradename decal	100163-04	1
Δ	General information decal	099548-05	1
Δ	Operation decal	099666-01	1
Δ	LP Warning decal	079663-01	1
Δ	Notice decal	099672-01	1
Δ	Hose/regulator assembly	LPA3090	1

(*) Standard hardware item, available locally.

(Δ) Not shown.

Dayton® Propane Construction Heater

⚠ WARNING

Never attempt to service heater while it is connected to propane supply, operating, or hot. Severe burns and electrical shock can occur.

Troubleshooting Chart

Symptom	Possible Cause(s)	Corrective Action
Fan does not turn when heater is plugged in	<ol style="list-style-type: none"> 1. No electrical power to heater 2. Fan hitting inside of heater shell 3. Fan blades bent 4. Defective motor 	<ol style="list-style-type: none"> 1. Check voltage to electrical outlet. If voltage is good, check heater power cord for breaks 2. Adjust motor/fan guard to keep fan from hitting inside of heater shell. Bend fan guard if necessary 3. Replace fan. See <i>Fan</i>, page 8 4. Replace motor. See <i>Motor</i>, page 8
Heater will not ignite	<ol style="list-style-type: none"> 1. User did not follow installation or operation instructions properly 2. No spark at ignitor. To test for spark, follow step 8 under <i>Ignitor</i>, page 9. If you see spark at ignitor, have heater serviced by qualified service person. If no spark seen: <ol style="list-style-type: none"> A) Loose or disconnected ignitor wire B) Wrong spark gap C) Piezo ignitor loose D) Bad ignitor electrode 	<ol style="list-style-type: none"> 1. Repeat installation and operation instructions. See <i>Installation</i>, page 6 and <i>Operation</i>, page 6 2. <ol style="list-style-type: none"> A) Check ignitor wire. Tighten or reattach loose ignitor wire. See Figure 14, page 9 for ignitor wire location B) Set gap between ignitor electrode and target plate to .17" C) Tighten nut holding piezo ignitor to base of heater D) Replace ignitor electrode. See <i>Ignitor</i>, page 9

Model 4E769B

Troubleshooting Chart (Continued)

Symptom	Possible Cause(s)	Corrective Action
Heater shuts down while running	<ol style="list-style-type: none"> 1. High surrounding air temperature causing thermal limit device to shut down heater 2. Restricted air flow 3. Damaged fan 4. Excessive dust or debris in surrounding area 	<ol style="list-style-type: none"> 1. This can happen when running heater in temperatures above 85°F. Run heater in cooler temperatures 2. Check heater inlet and outlet. Remove any obstructions 3. Replace fan. See <i>Fan</i>, page 8 4. Clean heater. See <i>Maintenance</i>, page 7

⚠ WARNING *Use only in areas free of high dust content.*

Accessories

Description	Part No.
10' Rubber Hose with Brass Fitting U.L. listed.	LPA1020
15' Rubber Hose with Brass Fitting U.L. listed.	LPA1030
Propane Gas Regulator U.L. listed.	LPA2110
Hose/Regulator Assembly U.L. listed.	LPA3090
Fuel Gas Connector Connects regulator to all standard propane tanks. U.L. and A.G.A. listed.	LPA4020
Tank Stabilizer	LPA5000

Dayton® Propane Construction Heater

LIMITED WARRANTY

DAYTON ONE-YEAR LIMITED WARRANTY. Natural gas construction heater, Models covered in this manual are warranted by Dayton Electric Mfg. Co. (Dayton) to the original user against defects in workmanship or materials under normal use for one year after date of purchase. Any part which is determined to be defective in material or workmanship and returned to an authorized service location, as Dayton designates, shipping costs prepaid, will be, as the exclusive remedy, repaired or replaced at Dayton's option. For limited warranty claim procedures, see PROMPT DISPOSITION below. This limited warranty gives purchasers specific legal rights which vary from jurisdiction to jurisdiction.

LIMITATION OF LIABILITY. To the extent allowable under applicable law, Dayton's liability for consequential and incidental damages is expressly disclaimed. Dayton's liability in all events is limited to, and shall not exceed, the purchase price paid.

WARRANTY DISCLAIMER. Dayton has made a diligent effort to provide product information and illustrate the product in this literature accurately; however, such information and illustrations are for the sole purpose of identification, and do not express or imply a warranty that the products are MERCHANTABLE, or FIT FOR A PARTICULAR PURPOSE, or that the products will necessarily conform to the illustrations or descriptions.

Except as provided below, no warranty or affirmation of fact, expressed or implied, other than as stated in "LIMITED WARRANTY" above is made or authorized by Dayton.

PRODUCT SUITABILITY. Many jurisdictions have codes and regulations governing sales, construction, installation, and/or use of products for certain purposes, which may vary from those in neighboring areas. While Dayton attempts to assure that its products comply with such codes, it cannot guarantee compliance, and cannot be responsible for how the product is installed or used. Before purchase and use of a product, review the product applications, and all applicable national and local codes and regulations, and be sure that the product, installation, and use will comply with them.

Certain aspects of disclaimers are not applicable to consumer products; e.g., (a) some jurisdictions do not allow the exclusion or limitation of incidental or consequential damages, so the above limitation or exclusion may not apply to you; (b) also, some jurisdictions do not allow limitations on how long an implied warranty lasts, consequently the above limitation may not apply to you; and (c) by law, during the period of this Limited Warranty, any implied warranties of implied merchantability or fitness for a particular purpose applicable to consumer products purchased by consumers, may not be excluded or otherwise disclaimed.

PROMPT DISPOSITION. Dayton will make a good faith effort for prompt correction or other adjustment with respect to any product which proves to be defective within limited warranty. For any product believed to be defective within limited warranty, first write or call dealer from whom product was purchased. Dealer will give additional directions. If unable to resolve satisfactorily, write to Dayton at address below, giving dealer's name, address, date and number of dealer's invoice, and describing the nature of the defect. Title and risk of loss pass to buyer on delivery to common carrier. If product was damaged in transit to you, file claim with carrier.

Manufactured for Dayton Electric Mfg. Co., 5959 W. Howard St., Niles, Illinois 60714 U.S.A.