

Digital Wireless Transmitter

The supplied CD-ROM includes the Operating Instructions for the DWT-B01 digital wireless transmitter (English, French, German, Italian, Spanish, and Japanese versions) and the frequency lists (English and Japanese versions) in PDF format.

For more details, see "Using the CD-ROM manual" on page 21.

Operating Instructions

Before operating the unit, please read this manual thoroughly and retain it for future reference.

DWT-B01

WARNING

Batteries shall not be exposed to excessive heat such as sunshine, fire or the like.

You are cautioned that any changes or modifications not expressly approved in this manual could void your authority to operate this equipment.

For the customers in the U.S.A.

This equipment has been tested and found to comply with the limits for a Class B digital device, pursuant to Part 15 of the FCC Rules. These limits are designed to provide reasonable protection against harmful interference in a residential installation. This equipment generates, uses, and can radiate radio frequency energy and, if not installed and used in accordance with the instructions, may cause harmful interference to radio communications. However, there is no guarantee that interference will not occur in a particular installation. If this equipment does cause harmful interference to radio or television reception, which can be determined by turning the equipment off and on, the user is encouraged to try to correct the interference by one or more of the following measures:

- Reorient or relocate the receiving antenna.
- Increase the separation between the equipment and receiver.
- Connect the equipment into an outlet on a circuit different from that to which the receiver is connected.
- Consult the dealer or an experienced radio/TV technician for help.

All interface cables used to connect peripherals must be shielded in order to comply with the limits for a digital device pursuant to Subpart B of Part 15 of FCC Rules.

*If you have any questions about this product, you may call;
Sony Customer Information Service Center
1-800-222-7669 or
<http://www.sony.com/>*

Declaration of Conformity

Trade Name: SONY
Model: DWT-B01
Responsible Party: Sony Electronics Inc.
Address: 16530 Via Esprillo, San Diego, CA 92127 U.S.A.
Telephone Number: 858-942-2230

This device complies with part 15 of the FCC Rules. Operation is subject to the following two conditions: (1) this device may not cause harmful interference, and (2) this device must accept any interference received, including interference that may cause undesired operation.

Notice for customers in the U.S.A.

Use of Sony wireless devices is regulated by the Federal Communications Commission as described in Part 74 subpart H of the FCC regulations and users authorized thereby are required to obtain an appropriate license.

IMPORTANT NOTE: To comply with the FCC RF exposure compliance requirements, no change to the antenna or the device is permitted, Any change to the antenna or the device could result in the device exceeding the RF exposure requirements and void user's authority to operate this device.

This device complies with FCC radiation exposure limits set forth for uncontrolled equipment and meets the FCC radio frequency (RF) Exposure Guidelines in Supplement C to OET65. This device has very low levels of RF energy that it is deemed to comply without testing of specific absorption radio (SAR).

For customers in Canada

This Class B digital apparatus complies with Canadian ICES-003.

For the customers in Canada

Operation is subject to the following two conditions: (1) this device may not cause interference, and (2) this device must accept any interference, including interference that may cause undesired operation of the device.

The term "IC" before the radio certification number only signifies that Industry Canada technical specifications were met.

To reduce potential radio interference to other users, the antenna type and its gain should be so chosen that the equivalent isotropically radiated power (EIRP) is not more than that required for successful communication.

This device has been designed to operate with an antenna having a maximum gain of 0 dB.

Antenna having a higher gain is strictly prohibited per regulations of Industry Canada.

The required antenna impedance is 50 ohms.

Notice for customers in Canada:

Use of Sony wireless devices is regulated by the Industry Canada as described in their Radio Standard Specification RSS-123. A licence is normally required. The local district office of Industry Canada should therefore be contacted. When the operation of the device is within the broadcast band, the licence is issued on no-interference, no protection basis with respect to broadcast signals.

For the customers in Europe

If the transmitter develops an abnormally high temperature, a burning odor or smoke during use, remove the battery holder and stop using the transmitter immediately.

Take care not to burn your fingers when removing the battery holder as the batteries may be very hot at this time.

AVERTISSEMENT

N'exposez pas les batteries à une chaleur excessive, au soleil ou près d'un feu par exemple.

Pour les utilisateurs au Canada

Cet appareil numérique de la classe B est conforme à la norme NMB-003 du Canada.

L'utilisation doit répondre aux deux conditions suivantes : (1) ce matériel ne doit pas provoquer de brouillage et (2) il doit accepter tout brouillage, même celui qui est susceptible d'affecter son fonctionnement.

La mention « IC: » devant le numéro de certification/ homologation signifie uniquement que les spécifications techniques d'Industrie Canada sont remplies.

Pour réduire les interférences radio potentielles pour les autres utilisateurs, le type d'antenne et son gain doivent être choisis de sorte que la puissance isotrope rayonnée équivalente (PIRE) ne soit pas supérieure à la puissance requise pour assurer la communication.

Ce dispositif a été conçu pour fonctionner avec une antenne à gain maximum de 0 dB. L'emploi d'une antenne à gain supérieur est strictement interdit par les règles d'Industrie Canada.

L'impédance d'antenne requise est de 50 ohms.

Remarque à l'intention des utilisateurs au Canada:

L'usage des appareils sans fil Sony est réglementé par l'Industrie Canada comme décrit dans leur Cahier des Normes Radioélectriques CNR-123.

Une licence est normalement requise.

Le bureau de l'Industrie Canada doit être contacté. Lorsque le fonctionnement de

l'appareil respecte les limites de la bande de radiodiffusion, la licence est accordée sur la base d'une non-interférence, non-protection pour les signaux de radiodiffusion.

Pour les clients en Europe

Si l'émetteur dégage une température anormalement élevée, une odeur de brûlé ou de la fumée pendant son utilisation, enlevez le support de piles et arrêtez toute utilisation immédiatement.

Attention à ne pas vous brûler les doigts lorsque vous retirez le support de piles car celles-ci peuvent être brûlantes.

WARNUNG

Akkus dürfen keinesfalls übermäßiger Wärmeeinwirkung ausgesetzt werden, wie z.B. Sonneneinstrahlung, Feuer o. ä.

Für Kunden in Europa

Wenn der Sender eine abnorm hohe Temperatur, einen Geruch nach Verbranntem oder Rauch entwickelt, entnehmen Sie den Batterie-Halter und stoppen Sie sofort den Betrieb des Senders. Achten Sie bei der Entnahme des Batterie-Halters darauf, sich nicht die Finger zu verbrennen, denn die Batterien könnten sehr heiß zu diesem Zeitpunkt sein.

AVVERTENZA

Le batterie non devono essere esposte a fonti di calore eccessivo come luce solare diretta, fuoco, ecc.

Per i clienti in Europa

Se il trasmettitore si surriscalda eccessivamente, rilascia odore di bruciato o del fumo, rimuovere il porta-pile e smettere di usare il trasmettitore immediatamente. Fare attenzione a non bruciarsi le dita quando si rimuove il porta-pile poiché le pile potrebbero essere molto calde.

ADVERTENCIA

No se deben exponer las baterías a una fuente de calor excesivo como la luz del sol, el fuego o similar.

Para los clientes de Europa

Si el transmisor desprende temperaturas altas no normales, olor a quemado o humo durante su uso, quite el soporte de las pilas y detenga el uso del transmisor inmediatamente.

Tenga cuidado de no quemarse los dedos cuando quite el soporte de las pilas pues las pilas pueden estar bastante calientes en este momento.

This model has an RF module of the FCC/IC approval built-in.

BUILT IN MODULE RM-215

FCC ID: AK8RM215
IC: 409B-RM215

For the customers in the U.S.A.

This device complies with part 15 of the FCC Rules. Operation is subject to the following two conditions: (1) this device may not cause harmful interference, and (2) this device must accept any interference received, including interference that may cause undesired operation.

CE1731

U.K.	470 - 862 MHz
Germany	470 - 606 MHz, 614 - 862 MHz
Norway	800 - 820 MHz
Luxembourg	470 - 862 MHz
Belgium	470 - 862 MHz
Denmark	800.100 - 819.900 MHz
France	470 - 830 MHz
Italy	470 - 854 MHz
Sweden	470 - 862 MHz
Switzerland	790 - 862 MHz
Finland	790.100 - 821.900 MHz, 854 - 862 MHz
Iceland	470 - 862 MHz
Turkey	470 - 862 MHz

For the customers in Europe

Hereby, Sony Corporation, declares that this DWT-B01 is in compliance with the essential requirements and other relevant provisions of the Directive 1999/5/EC. For details, please access the following URL: <http://www.compliance.sony.de/>

This product is intended to be used in the following countries : United Kingdom, Germany, Norway, Luxembourg, Belgium, Denmark, France, Italy, Sweden, Switzerland, Finland, Iceland, Turkey, and Czech Republic.

Pour les clients en Europe

Par la présente Sony Corporation déclare que l'appareil DWT-B01 est conforme aux exigences essentielles et aux autres dispositions pertinentes de la directive 1999/5/CE.

Pour toute information complémentaire, veuillez consulter l'URL suivante: <http://www.compliance.sony.de/>

Ce produit est prévu pour être utilisé dans les pays suivants: Royaume-Uni, Allemagne, Norvège, Luxembourg, Belgique, Danemark, France, Italie, Suède, Suisse, Finlande, Islande et Turquie.

Für Kunden in Europa

Hiermit erklärt Sony Corporation, dass sich das Gerät DWT-B01 in Übereinstimmung mit den grundlegenden Anforderungen und den übrigen einschlägigen Bestimmungen der Richtlinie 1999/5/EG befindet.

Weitere Informationen erhältlich unter: <http://www.compliance.sony.de/>

Dieses Produkt ist für den Gebrauch in den folgenden Ländern vorgesehen: Vereinigtes Königreich, Deutschland, Norwegen, Luxemburg, Belgien, Dänemark, Frankreich, Italien, Schweden, Schweiz, Finnland, Island und Türkei.

Per i clienti in Europa

Con la presente Sony Corporation dichiara che questo DWT-B01 è conforme ai

requisiti essenziali ed alle altre disposizioni pertinenti stabilite dalla direttiva 1999/5/CE.

Per ulteriori dettagli, si prega di consultare il seguente URL:

<http://www.compliance.sony.de/>

Questo prodotto è destinato all'uso nei seguenti paesi: Regno Unito, Germania, Norvegia, Lussemburgo, Belgio, Danimarca, Francia, Italia, Svezia, Svizzera, Finlandia, Islanda e Turchia.

Para los clientes de Europa

Por medio de la presente Sony Corporation declara que el DWT-B01 cumple con los requisitos esenciales y cualesquiera otras disposiciones aplicables o exigibles de la Directiva 1999/5/CE.

Para mayor información, por favor consulte el siguiente URL:

<http://www.compliance.sony.de/>

Este producto está destinado a utilizarse en los siguientes países: Reino Unido, Alemania, Noruega, Luxemburgo, Bélgica, Dinamarca, Francia, Italia, Suecia, Suiza, Finlandia, Islandia y Turquía.

Voor de klanten in Europa

Hierbij verklaart Sony Corporation dat het toestel DWT-B01 in overeenstemming is met de essentiële eisen en de andere relevante bepalingen van richtlijn 1999/5/EG.

Nadere informatie kunt u vinden op:

<http://www.compliance.sony.de/>

Dit product is bedoeld om in volgende landen gebruikt te worden: Verenigd Koninkrijk, Duitsland, Noorwegen, Luxemburg, België, Denemarken, Frankrijk, Italië, Zweden, Zwitserland, Finland, IJsland en Turkije.

For kunder i Europa

Härmed intygar Sony Corporation att denna DWT-B01 står i överensstämmelse med de väsentliga egenskapskrav och övriga relevanta bestämmelser som framgår av direktiv 1999/5/EG.

För ytterligare information gå in på följande hemsida: <http://www.compliance.sony.de/>

Den här produkten är avsedd för användning i följande länder: Storbritannien, Tyskland, Norge, Luxembourg, Belgien, Danmark, Frankrike, Italien, Sverige, Schweiz, Finland, Island och Turkiet.

Para os clientes da Europa

Sony Corporation declara que este DWT-B01 está conforme com os requisitos essenciais e outras disposições da Directiva 1999/5/CE.

Para mais informacoes, por favor consulte a seguinte URL:

<http://www.compliance.sony.de/>

Este produto destina-se a ser usado nos seguintes países: Reino Unido, Alemanha, Noruega, Luxemburgo, Bélgica, Dinamarca, França, Itália, Suécia, Suíça, Finlândia, Islândia e Turquia.

For kunder i Europa

Undertegnede Sony Corporation erklærer herved, at følgende udstyr DWT-B01 overholder de væsentlige krav og øvrige relevante krav i direktiv 1999/5/EF.

For yderligere information gå ind på følgende hjemmeside:

<http://www.compliance.sony.de/>

Dette produkt er beregnet til brug i de følgende lande: Storbritannien, Tyskland, Norge, Luxembourg, Belgien, Danmark, Frankrig, Italien, Sverige, Schweiz, Finland, Island og Tyrkiet.

Euroopassa oleville asiakkaille

Sony Corporation vakuuttaa täten että DWT-B01 tyyppinen laite on direktiivin 1999/5/EY oleellisten vaatimusten ja sitä koskevien direktiivin muiden ehtojen mukainen.

Halutessasi lisätietoja, käy osoitteessa:

<http://www.compliance.sony.de/>

Tämä tuote on tarkoitettu käytettäväksi seuraavissa maissa: Yhdistynyt kuningaskunta, Saksa, Norja, Luxemburg, Belgia, Tanska, Ranska, Italia, Ruotsi, Sveitsi, Suomi, Islanti ja Turkki.

For kundene i Europa

Sony Corporation erklærer herved at utstyret DWT-B01 er i samsvar med de grunnleggende krav og øvrige relevante krav i direktiv 1999/5/EF.

For flere detaljer, vennligst se:

<http://www.compliance.sony.de/>

Dette produktet er ment for bruk i følgende land: Storbritannia, Tyskland, Norge, Luxemburg, Belgia, Danmark, Frankrike, Italia, Sverige, Sveits, Finland, Island og Tyrkia.

Για τους πελάτες στην Ευρώπη

Με την παρούσα η Sony Corporation δηλώνει ότι DWT-B01

συμμορφώνεται προς της ουσιώδεις απαιτήσεις και τις λοιπές σχετικές διατάξεις της οδηγίας 1999/5/EK..

Για λεπτομέρειες παρακαλούμε όπως ελένξετε την ακόλουθη σελίδα του διαδικτύου:

<http://www.compliance.sony.de/>

Το προϊόν προορίζεται για χρήση στις εξής χώρες: Ηνωμένο Βασίλειο, Γερμανία, Νορβηγία, Λουξεμβούργο, Βέλγιο, Δανία, Γαλλία, Ιταλία, Σουηδία, Ελβετία, Φινλανδία, Ισλανδία και Τουρκία.

За клиентите в Европа

С настоящето Сони Корпорация декларира, че този DWT-B01 отговаря на основните изисквания и другите съответстващи клаузи на Директива 1999/5/EC.

Подробности може да намерите на Интернет страницата :

<http://www.compliance.sony.de/>.

Този продукт е предназначен за употреба в следните държави: Обединеното кралство, Германия, Норвегия, Люксембург, Белгия, Дания, Франция, Италия, Швеция, Швейцария, Финландия, Исландия и Турция.

Pro zákazníky v Evropě

Sony Corporation tímto prohlašuje, že tento DWT-B01 je ve shodě se základními požadavky a dalšími příslušnými ustanoveními směrnice 1999/5/ES.

Podrobnosti lze získat na následující URL:

<http://www.compliance.sony.de/>

Tento produkt je určen k použití v následujících zemích: Spojené království, Německo, Norsko, Lucembursko, Belgie, Dánsko, Francie, Itálie, Švédsko, Švýcarsko, Finsko, Island a Turecko.

Euroopa klientidele

Sony Corporation kinnitab käesolevaga seadme DWT-B01 vastavust 1999/5/EÜ direktiivi põhinõuetele ja nimetatud direktiivist tulenevatele teistele asjakohastele sätetele.

Üksikasjalikum info:

<http://www.compliance.sony.de/>.

See toode on ettenähtud kasutamiseks järgmistes riikides: Suurbritannia, Saksamaa, Norra, Luksemburg, Belgia, Taani, Prantsusmaa, Itaalia, Rootsi, Šveits, Soome, Island ja Türgi.

Európai vásárlóink fi gyelmébe

Alulírott, Sony Corporation nyilatkozom, hogy a(z) DWT-B01 megfelel a vonatkozó alapvető követelményeknek és az 1999/5/EC irányelv egyéb előírásainak.

További információkat a következő weboldalon találhat:

<http://www.compliance.sony.de/>

Ez a termék a következő országokban használható: Egyesült Királyság, Németország, Norvégia, Luxemburg, Belgium, Dánia, Franciaország, Olaszország, Svédország, Svájc, Finnország, Izland és Törökország.

Klientiem Eiropā

Ar šo Sony Corporation deklarē, ka DWT-B01 atbilst Direktīvas 1999/5/EK būtiskajām prasībām un citiem ar to saistītajiem noteikumiem.

Plašāka informācija ir pieejama: <http://www.compliance.sony.de/>

Šis produkts ir paredzēts lietošanai šādās valstīs: Apvienotā Karaliste, Vācija, Norvēģija, Luksemburga, Beļģija, Dānija, francija, Itālija, Zviedrija, Šveice, Somija, Īslande un Turcija.

Klientams Europoje

Šiuo Sony Corporation deklaruoja, kad šis DWT-B01 atitinka esminius reikalavimus ir kitas 1999/5/EB Direktyvos nuostatas. Susipažinti su visu atitiktis deklaracijos turiniu Jūs galite interneto tinklalapyje: <http://www.compliance.sony.de/>

Šis gaminys skirtas naudoti šiose šalyse: Jungtinėje Karalystėje, Vokietijoje, Norvegijoje, Liuksemburge, Belgijoje, Danijoje, Prancūzijoje, Italijoje, Švedijoje, Šveicarijoje, Suomijoje, Islandijoje ir Turkijoje.

Dotyczy klientów z Europy

Niniejszym Sony Corporation oświadcza, że DWT-B01 jest zgodne z zasadniczymi wymaganiami oraz innymi stosownymi postanowieniami Dyrektywy 1999/5/WE. Szczegółowe informacje znaleźć można pod następującym adresem URL: <http://www.compliance.sony.de/>

Ten produkt jest przeznaczony do użytku w następujących krajach: Wielkiej Brytanii, Niemczech, Norwegii,

Luksemburgu, Belgii, Danii, Francji, Włoszech, Szwecji, Szwajcarii, Finlandii, Islandii i Turcji.

Pentru clienții din Europa

Prin prezenta, Sony Corporation declară că acest DWT-B01 respectă cerințele esențiale și este în conformitate cu prevederile Directivei 1995/5/EC. Pentru detalii, vă rugăm accesați următoarea adresă:
<http://www.compliance.sony.de/>

Acest produs este destinat utilizării în următoarele țări: Regatul Unit, Germania, Norvegia, Luxemburg, Belgia, Danemarca, Franța, Italia, Suedia, Elveția, Finlanda, Islanda și Turcia.

Pre zákazníkov v Európe

Sony Corporation týmto vyhlasuje, že DWT-B01 spĺňa základné požiadavky a všetky príslušné ustanovenia Smernice 1999/5/ES. Podrobnosti získate na nasledovnej webovej adrese:
<http://www.compliance.sony.de/>

Tento produkt je určený na používanie v nasledovných krajinách: Veľká Británia, Nemecko, Nórsko, Luxembursko, Belgicko, Dánsko, Francúzsko, Taliansko, Švédsko, Švajčiarsko, Fínsko, Island a Turecko.

Za stranke v Evropi

Sony Corporation izjavlja, da je ta DWT-B01 v skladu z bistvenimi zahtevami in ostalimi relevantnimi določili direktive 1999/5/ES. Za podrobnosti vas naprošamo, če pogledate na URL:
<http://www.compliance.sony.de/>

Izdelek je namenjen za uporabo v naslednjih državah: Veliki Britaniji, Nemčiji, Norveški, Luksemburgu, Belgiji, Danski, Franciji, Italiji, Švedski, Švici, Finski, Islandiji in Turčiji.

Note for customer in UK:

The use of this equipment is subject to individual license granted by the National Frequency Administration Authority.

Hinweis für Kunden in Großbritannien:

Der Gebrauch dieses Geräts unterliegt einer entsprechenden Lizenz von der nationalen Frequenzverwaltungsbehörde.

Merknad for kundene i Storbritannia:

Bruken av dette utstyret er underlagt en spesiell lisens som utstedes av nasjonale frekvensforvaltningsmyndigheter.

Remarque pour les clients résidant au Royaume-Uni:

L'utilisation de cet équipement est soumise à la licence individuelle accordée par les autorités d'administration des fréquences nationales.

Opmerking voor klanten in het Verenigd Koninkrijk:

Het gebruik van deze apparatuur is onderhevig aan een afzonderlijke licentie die is verleend door de nationale autoriteit voor frequentiebeheer.

Bemærkning til kunder i Storbritannien:

Brugen af dette udstyr er underlagt individuel licens givet at telemyndighederne.

Nota per i clienti nel Regno Unito:

L'uso di questo apparecchio è soggetto ad una licenza individuale accordata dall'Autorità per l'amministrazione delle frequenze nazionali..

För kunder i Storbritannien:

Användandet av den här utrustningen sker under enskilda licenser som utfärdas av den nationella myndighet som handhar frekvenstillstånd.

Ilmoitus Yhdistyneessä kuningaskunnassa asuville asiakkaille:

Laitteiston käyttöön tarvitaan paikallisen viestintäviranomaisen myöntämä henkilökohtainen lupa.

Athugasemd fyrir viðskiptavin í Bretlandi:

Notkun þessa búnaðar þarf að vera samkvæmt leyfi frá fjarskiptayfirvöldum.

İngiltere'deki müşteriler için not:

Bu cihazın kullanımı, Ulusal Frekans Yönetimi Makamı tarafından verilen bireysel lisansa tabidir.

Note for customer in Germany:

According to German regulation this equipment can only operate in channels (specify which channels are allowed). The use of this equipment is subject to individual license granted by the National Frequency Administration Authority.

Hinweis für Kunden in Deutschland:

Gemäß den Vorschriften in Deutschland kann dieses Gerät nur auf bestimmten Kanälen betrieben werden (zulässige Kanäle angeben). Der Gebrauch dieses Geräts unterliegt einer entsprechenden Lizenz von der nationalen Frequenzverwaltungsbehörde.

Merknad for kundene i Tyskland:

I henhold til tyske forskrifter kan dette utstyret kun brukes i kanal (angi hvilke kanaler som er tillatt). Bruken av dette utstyret er underlagt en spesiell lisens som utstedes av nasjonale frekvensforvaltningsmyndigheter.

Remarque pour les clients résidant en Allemagne:

Conformément à la réglementation allemande, cet équipement fonctionne uniquement avec des canaux (spécifiez les canaux autorisés).

L'utilisation de cet équipement est soumise à la licence individuelle accordée par les autorités d'administration des fréquences nationales.

Opmerking voor klanten in Duitsland:

Volgens de Duitse wetgeving mag deze apparatuur alleen werken in kanalen (opgeven welke kanalen zijn toegestaan). Het gebruik van deze apparatuur is onderhevig aan een afzonderlijke licentie die is verleend door de nationale autoriteit voor frequentiebeheer.

Bemærkning til kunder i Tyskland:

I henhold til tysk lovgivning kan dette udstyr kun fungere i kanaler (angiv, hvilke kanaler, der er tilladt). Bruget af dette udstyr er underlagt individuel licens givet af teledirektoratet.

Nota per i clienti in Germania:

In base alle norme vigenti in Germania, il presente apparecchio può essere utilizzato solo su canali (specificare i canali consentiti). L'uso di questo apparecchio è soggetto ad una licenza individuale accordata dall'Autorità per l'amministrazione delle frequenze nazionali.

För kunder i Tyskland:

Enligt tysk lagstiftning får den här utrustningen endast användas med följande kanaler (ange vilka kanaler som är tillåtna). Användandet av den här utrustningen sker under enskilda licenser som utfärdas av den nationella myndighet som handhar frekvenstillstånd.

Ilmoitus Saksassa asuville asiakkaille:

Saksassa voimassa olevien määräysten mukaan tätä laitetta saa käyttää ainoastaan kanavilla (ilmoita sallitut kanavat).

Laitteiston käyttöön tarvitaan paikallisen viestintäviranomaisen myöntämä henkilökohtainen lupa.

Athugasemd fyrir viðskiptavin í Þýskalandi:

Samkvæmt þýskum reglum má aðeins nota þennan búnað á rásum (tilgreinið leyfilegar rásir).

Notkun þessa búnaðar þarf að vera samkvæmt leyfi frá fjarskiptayfirvöldum.

Almanya'daki müşteriler için not:

Almanya mevzuatlarına göre, bu cihaz yalnızca (izin verilen kanalları belirtin) kanallarda çalışabilir.

Bu cihazın kullanımı, Ulusal Frekans Yönetimi Makamı tarafından verilen bireysel lisansa tabidir.

Note for customer in Norway:

According to Norwegian regulation this equipment can only operate in channels (specify which channels are allowed) with a maximum RF output power of 20mW.

The use of this equipment is subject to individual license granted by the National Frequency Administration Authority.

Hinweis für Kunden in Norwegen:

Gemäß den Vorschriften in Norwegen kann dieses Gerät nur auf bestimmten Kanälen betrieben werden (zulässige Kanäle angeben), und zwar mit einer maximalen HF-Ausgangsleistung von 20 mW.

Der Gebrauch dieses Geräts unterliegt einer entsprechenden Lizenz von der nationalen Frequenzverwaltungsbehörde.

Merknad for kundene i Norge:

I henhold til norske forskrifter kan dette utstyret kun brukes i kanal (angi hvilke kanaler som er tillatt) med maksimal RF-utgangseffekt på 20 mW.

Bruken av dette utstyret er underlagt en spesiell lisens som utstedes av nasjonale frekvensforvaltningsmyndigheter.

Remarque pour les clients résidant en Norvège:

Conformément à la réglementation norvégienne, cet équipement fonctionne uniquement avec des canaux (spécifiez les canaux autorisés) ayant une puissance de sortie RF maximale de 20 mW.

L'utilisation de cet équipement est soumise à la licence individuelle accordée par les autorités d'administration des fréquences nationales.

Opmerking voor klanten in Noorwegen:

Volgens de Noorse wetgeving mag deze apparatuur alleen werken in kanalen (opgeven welke kanalen zijn toegestaan) met een maximaal RF-uitgangsvermogen van 20 mW.

Het gebruik van deze apparatuur is onderhevig aan een afzonderlijke licentie die is verleend door de nationale autoriteit voor frequentiebeheer.

Bemærkning til kunder i Norge:

I henhold til norsk lovgivning kan dette utstyr kun fungere i kanaler (angiv, hvilke kanaler, der er tilladt) med en maksimal RF-udgangseffekt på 20 mW.

Brugen af dette udstyr er underlagt individuel licens givet af telemyndighederne.

Nota per i clienti in Norvegia:

In base alle norme vigenti in Norvegia, il presente apparecchio può essere utilizzato solo su canali (specificare i canali consentiti) con una potenza di uscita RF massima di 20mW.

L'uso di questo apparecchio è soggetto ad una licenza individuale accordata dall'Autorità per l'amministrazione delle frequenze nazionali.

För kunder i Norge:

Enligt norsk lagstiftning får den här utrustningen endast användas med följande kanaler (ange vilka kanaler som är tillåtna) med en maximal RF-uteffekt på 20 mW.

Användandet av den här utrustningen sker under enskilda licenser som utfärdas av den nationella myndighet som handhar frekvenstillstånd.

Ilmoitus Norjassa asuville asiakkaille:

Norjassa voimassa olevien määrysten mukaan tätä laitetta saa käyttää ainoastaan kanavilla (ilmoita sallitut kanavat) ja siten, että RF-lähetysten enimmäisteho on 20 mW.

Laitteiston käyttöön tarvitaan paikallisen viestintäviranomaisen myöntämä henkilökohtainen lupa.

Athugasemd fyrir viðskiptavin í Noregi:

Samkvæmt norskum reglum má aðeins nota þennan búnað á rásum (tilgreinið leyfilegar rásir) og er hámarkssendistyrkur útvarpsbylgjana 20mW.

Notkun þessa búnaðar þarf að vera samkvæmt leyfi frá fjarskiptayfirvöldum.

Norveç'teki müşteriler için not:

Norveç mevzuatlarına göre, bu cihaz yalnızca RF çıkış gücü maksimum 20mW olan (izin verilen kanalları belirtin) kanallarda çalışabilir.

Bu cihazın kullanımı, Ulusal Frekans Yönetimi Makamı tarafından verilen bireysel lisansa tabidir.

Note for customer in Luxembourg:

The use of this equipment is subject to individual license granted by the National Frequency Administration Authority.

Hinweis für Kunden in Luxemburg:

Der Gebrauch dieses Geräts unterliegt einer entsprechenden Lizenz von der nationalen Frequenzverwaltungsbehörde.

Merknad for kundene i

Luxembourg:

Bruken av dette utstyret er underlagt en spesiell lisens som utstedes av nasjonale frekvensforvaltningsmyndigheter.

Remarque pour les clients résidant au Luxembourg:

L'utilisation de cet équipement est soumise à la licence individuelle accordée par les autorités d'administration des fréquences nationales.

Opmerking voor klanten in Luxembourg:

Het gebruik van deze apparatuur is onderhevig aan een afzonderlijke licentie die is verleend door de nationale autoriteit voor frequentiebeheer.

Bemærkning til kunder i Luxembourg:

Brugen af dette udstyr er underlagt individuel licens givet at telemyndighederne.

Nota per i clienti in Lussemburgo:

L'uso di questo apparecchio è soggetto ad una licenza individuale accordata dall'Autorità per l'amministrazione delle frequenze nazionali.

För kunder i Luxembourg:

Användandet av den här utrustningen sker under enskilda licenser som utfärdas av den nationella myndighet som handhar frekvenstillstånd.

Ilmoitus Luxemburgissa asuville asiakkaille:

Laitteiston käyttöön tarvitaan paikallisen viestintäviranomaisen myöntämä henkilökohtainen lupa.

Athugasemd fyrir viðskiptavin í Lúxemborg:

Notkun þessa búnaðar þarf að vera samkvæmt leyfi frá fjarskiptayfirvöldum.

Lüksemburg'taki müşteriler için not:

Bu cihazın kullanımı, Ulusal Frekans Yönetimi Makamı tarafından verilen bireysel lisansa tabidir.

Note for customer in Belgium:

The use of this equipment is subject to individual license granted by the National Frequency Administration Authority.

Hinweis für Kunden in Belgien:

Der Gebrauch dieses Geräts unterliegt einer entsprechenden Lizenz von der nationalen Frequenzverwaltungsbehörde.

Merknad for kundene i Belgia:

Bruken av dette utstyret er underlagt en spesiell lisens som utstedes av nasjonale frekvensforvaltningsmyndigheter.

Remarque pour les clients résidant en Belgique:

L'utilisation de cet équipement est soumise à la licence individuelle accordée par les autorités d'administration des fréquences nationales.

Opmerking voor klanten in België:

Het gebruik van deze apparatuur is onderhevig aan een afzonderlijke licentie die is verleend door de nationale autoriteit voor frequentiebeheer.

Bemærkning til kunder i Belgien:

Brugen af dette udstyr er underlagt individuel licens givet af teledirektoratet.

Nota per i clienti in Belgio:

L'uso di questo apparecchio è soggetto ad una licenza individuale accordata dall'Autorità per l'amministrazione delle frequenze nazionali.

För kunder i Belgien:

Användandet av den här utrustningen sker under enskilda licenser som utfärdas av den

nationella myndighet som handhar frekvenstillstånd.

Ilmoitus Belgiassa asuville asiakkaille:

Laitteiston käyttöön tarvitaan paikallisen viestintäviranomaisen myöntämä henkilökohtainen lupa.

Athugasemd fyrir viðskiptavin í Belgíu:

Notkun þessa búnaðar þarf að vera samkvæmt leyfi frá fjarskiptayfirvöldum.

Belçika'daki müşteriler için not:

Bu cihazın kullanımı, Ulusal Frekans Yönetimi Makamı tarafından verilen bireysel lisansa tabidir.

Note for customer in Denmark:

According to Danish regulation this equipment can only operate in channels (specify which channels are allowed). The use of this equipment is subject to individual license granted by the National Frequency Administration Authority.

Hinweis für Kunden in Dänemark:

Gemäß den Vorschriften in Dänemark kann dieses Gerät nur auf bestimmten Kanälen betrieben werden (zulässige Kanäle angeben).

Der Gebrauch dieses Geräts unterliegt einer entsprechenden Lizenz von der nationalen Frequenzverwaltungsbehörde.

Merknad for kundene i Danmark:

I henhold til danske forskrifter kan dette udstyret kun bruges i kanal (angi hvilke kanaler som er tillatt).

Bruken av dette utstyret er underlagt en spesiell lisens som utstedes av nasjonale frekvensforvaltningsmyndigheter.

Remarque pour les clients résidant au Danemark:

Conformément à la réglementation danoise, cet équipement fonctionne uniquement

avec des canaux (spécifiez les canaux autorisés).

L'utilisation de cet équipement est soumise à la licence individuelle accordée par les autorités d'administration des fréquences nationales.

Opmerking voor klanten in Denemarken:

Volgens de Deense wetgeving mag deze apparatuur alleen werken in kanalen (opgeven welke kanalen zijn toegestaan). Het gebruik van deze apparatuur is onderhevig aan een afzonderlijke licentie die is verleend door de nationale autoriteit voor frequentiebeheer.

Bemærkning til kunder i Danmark

I henhold til dansk lovgivning kan dette udstyr kun fungere i kanaler (angiv, hvilke kanaler, der er tilladt).

Brugen af dette udstyr er underlagt til individuel licens givet af teledirektoratet.

Nota per i clienti in Danimarca:

In base alle norme vigenti in Danimarca, il presente apparecchio può essere utilizzato solo su canali (specificare i canali consentiti).

L'uso di questo apparecchio è soggetto ad una licenza individuale accordata dall'Autorità per l'amministrazione delle frequenze nazionali.

För kunder i Danmark:

Enligt dansk lagstiftning får den här utrustningen endast användas med följande kanaler (ange vilka kanaler som är tillåtna). Användandet av den här utrustningen sker under enskilda licenser som utfärdas av den nationella myndighet som handhar frekvenstillstånd.

Ilmoitus Tanskassa asuville asiakkaille:

Tanskassa voimassa olevien määräysten mukaan tätä laitetta saa käyttää ainoastaan kanavilla (ilmoita sallitut kanavat).

Laitteiston käyttöön tarvitaan paikallisen viestintäviranomaisen myöntämä henkilökohtainen lupa.

Athugasemd fyrir viðskiptavin í Danmörku:

Samkvæmt dönskum reglum má aðeins nota þennan búnað á rásum (tilgreinið leyfilegar rásir).

Notkun þessa búnaðar þarf að vera samkvæmt leyfi frá fjarskiptayfirvöldum.

Danimarka'daki müşteriler için not:

Danimarka mevzuatlarına göre, bu cihaz yalnızca (izin verilen kanalları belirtin) kanallarda çalışabilir.

Bu cihazın kullanımı, Ulusal Frekans Yönetimi Makamı tarafından verilen bireysel lisansa tabidir.

Note for customer in Italy:

According to Italian regulation this equipment can only operate in channels (specify which channels are allowed). The use of this equipment is subject to individual license granted by the National Frequency Administration Authority.

Hinweis für Kunden in Italien:

Gemäß den Vorschriften in Italien kann dieses Gerät nur auf bestimmten Kanälen betrieben werden (zulässige Kanäle angeben).

Der Gebrauch dieses Geräts unterliegt einer entsprechenden Lizenz von der nationalen Frequenzverwaltungsbehörde.

Merknad for kundene i Italia:

I henhold til italienske forskrifter kan dette utstyret kun brukes i kanal (angi hvilke kanaler som er tillatt).

Bruken av dette utstyret er underlagt en spesiell lisens som utstedes av nasjonale frekvensforvaltningsmyndigheter.

Remarque pour les clients résidant en Italie:

Conformément à la réglementation italienne, cet équipement fonctionne

uniquement avec des canaux (spécifiez les canaux autorisés).

L'utilisation de cet équipement est soumise à la licence individuelle accordée par les autorités d'administration des fréquences nationales.

Opmerking voor klanten in Italië:

Volgens de Italiaanse wetgeving mag deze apparatuur alleen werken in kanalen (opgeven welke kanalen zijn toegestaan). Het gebruik van deze apparatuur is onderhevig aan een afzonderlijke licentie die is verleend door de nationale autoriteit voor frequentiebeheer.

Bemærkning til kunder i Italien:

I henhold til italiensk lovgivning kan dette udstyr kun fungere i kanaler (angiv, hvilke kanaler, der er tilladt).

Brugen af dette udstyr er underlagt individuel licens givet af teledirektoratet.

Nota per i clienti in Italia:

In base alle norme vigenti in Italia, il presente apparecchio può essere utilizzato solo su canali (specificare i canali consentiti).

L'uso di questo apparecchio è soggetto ad una licenza individuale accordata dall'Autorità per l'amministrazione delle frequenze nazionali.

För kunder i Italien:

Enligt italiensk lagstiftning får den här utrustningen endast användas med följande kanaler (ange vilka kanaler som är tillåtna). Användandet av den här utrustningen sker under enskilda licenser som utfärdas av den nationella myndighet som handhar frekvenstillstånd.

Ilmoitus Italiassa asuville asiakkaille:

Italiassa voimassa olevien määräysten mukaan tätä laitetta saa käyttää ainoastaan kanavilla (ilmoita sallitut kanavat).

Laitteiston käyttöön tarvitaan paikallisen viestintäviranomaisen myöntämä henkilökohtainen lupa.

Athugasemd fyrir viðskiptavin á Ítalíu:

Samkvæmt ítölskum reglum má aðeins nota þennan búnað á rásum (tilgreinið leyfilegar rásir).

Notkun þessa búnaðar þarf að vera samkvæmt leyfi frá fjarskiptayfirvöldum.

İtalya'daki müşteriler için not:

İtalya mevzuatlarına göre, bu cihaz yalnızca (izin verilen kanalları belirtin) kanallarda çalışabilir.

Bu cihazın kullanımını, Ulusal Frekans Yönetimi Makamı tarafından verilen bireysel lisansa tabidir.

Note for customer in Sweden:

According to Swedish regulation this equipment can only operate in channels (specify which channels are allowed).

The use of this equipment is subject to individual license granted by the National Frequency Administration Authority.

Hinweis für Kunden in Schweden:

Gemäß den Vorschriften in Schweden kann dieses Gerät nur auf bestimmten Kanälen betrieben werden (zulässige Kanäle angeben).

Der Gebrauch dieses Geräts unterliegt einer entsprechenden Lizenz von der nationalen Frequenzverwaltungsbehörde.

Merknad för kundene i Sverige:

I henhold til svenske forskrifter kan dette utstyret kun brukes i kanal (angi hvilke kanaler som er tillatt).

Bruken av dette utstyret er underlagt en spesiell lisens som utstedes av nasjonale frekvensforvaltningsmyndigheter.

Remarque pour les clients résidant en Suède:

Conformément à la réglementation suédoise, cet équipement fonctionne uniquement avec des canaux (spécifiez les canaux autorisés).

L'utilisation de cet équipement est soumise à la licence individuelle accordée par les autorités d'administration des fréquences nationales.

Opmerking voor klanten in Zweden:

Volgens de Zweedse wetgeving mag deze apparatuur alleen werken in kanalen (opgeven welke kanalen zijn toegestaan). Het gebruik van deze apparatuur is onderhevig aan een afzonderlijke licentie die is verleend door de nationale autoriteit voor frequentiebeheer.

Bemærkning til kunder i Sverige:

I henhold til svensk lovgivning kan dette udstyr kun fungere i kanaler (angiv, hvilke kanaler, der er tilladt).

Brugen af dette udstyr er underlagt individuel licens givet af teledirektoratet.

Nota per i clienti in Svezia:

In base alle norme vigenti in Svezia, il presente apparecchio può essere utilizzato solo su canali (specificare i canali consentiti).

L'uso di questo apparecchio è soggetto ad una licenza individuale accordata dall'Autorità per l'amministrazione delle frequenze nazionali.

För kunder i Sverige:

Enligt svensk lagstiftning får den här utrustningen endast användas med följande kanaler (ange vilka kanaler som är tillåtna). Användandet av den här utrustningen sker under enskilda licenser som utfärdas av den nationella myndighet som handhar frekvenstillstånd.

Ilmoitus Ruotsissa asuville asiakkaille:

Ruotsissa voimassa olevien määräysten mukaan tätä laitetta saa käyttää ainoastaan kanavilla (ilmoita sallitut kanavat).

Laitteiston käyttöön tarvitaan paikallisen viestintäviranomaisen myöntämä henkilökohtainen lupa.

Athugasemd fyrir viðskiptavin í Svíþjóð:

Samkvæmt sænskum reglum má aðeins nota þennan búnað á rásum (tilgreinið leyfilegar rásir).

Notkun þessa búnaðar þarf að vera samkvæmt leyfi frá fjarskiptayfirvöldum.

İsveç'teki müşteriler için not:

İsveç mevzuatlarına göre, bu cihaz yalnızca (izin verilen kanalları belirtin) kanallarda çalışabilir.

Bu cihazın kullanımı, Ulusal Frekans Yönetimi Makamı tarafından verilen bireysel lisansa tabidir.

Note for customer in Switzerland:

According to Swiss regulation this equipment can only operate in channels (specify which channels are allowed).

The use of this equipment is subject to individual license granted by the National Frequency Administration Authority.

Hinweis für Kunden in der Schweiz:

Gemäß den Vorschriften in der Schweiz kann dieses Gerät nur auf bestimmten Kanälen betrieben werden (zulässige Kanäle angeben).

Der Gebrauch dieses Geräts unterliegt einer entsprechenden Lizenz von der nationalen Frequenzverwaltungsbehörde.

Merknad for kundene i Sveits:

I henhold til sveitsiske forskrifter kan dette utstyret kun brukes i kanal (angi hvilke kanaler som er tillatt).

Bruken av dette utstyret er underlagt en spesiell lisens som utstedes av nasjonale frekvensforvaltningsmyndigheter.

Remarque pour les clients résidant en Suisse:

Conformément à la réglementation suisse, cet équipement fonctionne uniquement avec des canaux (spécifiez les canaux autorisés).

L'utilisation de cet équipement est soumise à la licence individuelle accordée par les autorités d'administration des fréquences nationales.

Opmerking voor klanten in Zwitserland:

Volgens de Zwitserse wetgeving mag deze apparatuur alleen werken in kanalen (opgeven welke kanalen zijn toegestaan). Het gebruik van deze apparatuur is onderhevig aan een afzonderlijke licentie die is verleend door de nationale autoriteit voor frequentiebeheer.

Bemærkning til kunder i Schweiz:

I henhold til schweizisk lovgivning kan dette udstyr kun fungere i kanaler (angiv, hvilke kanaler, der er tilladt). Brugen af dette udstyr er underlagt individuel licens givet af telemyndighederne.

Nota per i clienti in Svizzera:

In base alle norme vigenti in Svizzera, il presente apparecchio può essere utilizzato solo su canali (specificare i canali consentiti).

L'uso di questo apparecchio è soggetto ad una licenza individuale accordata dall'Autorità per l'amministrazione delle frequenze nazionali.

För kunder i Schweiz:

Enligt schweizisk lagstiftning får den här utrustningen endast användas med följande kanaler (ange vilka kanaler som är tillåtna). Användandet av den här utrustningen sker under enskilda licenser som utfärdas av den

nationella myndighet som handhar frekvenstillstånd.

Ilmoitus Sveitsissä asuville asiakkaille:

Sveitsissä voimassa olevien määräysten mukaan tätä laitetta saa käyttää ainoastaan kanavilla (ilmoita sallitut kanavat). Laitteiston käyttöön tarvitaan paikallisen viestintäviranomaisen myöntämä henkilökohtainen lupa.

Athugasemd fyrir viðskiptavin í Sviss:

Samkvæmt svissneskum reglum má aðeins nota þennan búnað á rásum (tilgreinið leyfilegar rásir).

Notkun þessa búnaðar þarf að vera samkvæmt leyfi frá fjarskiptayfirvöldum.

İsviçre'deki müşteriler için not:

İsviçre mevzuatlarına göre, bu cihaz yalnızca (izin verilen kanalları belirtin) kanallarda çalışabilir.

Bu cihazın kullanımı, Ulusal Frekans Yönetimi Makamı tarafından verilen bireysel lisansa tabidir.

Note for customer in Finland:

According to Finnish regulation this equipment can only operate in channels (specify which channels are allowed). The use of this equipment is subject to individual license granted by the National Frequency Administration Authority.

Hinweis für Kunden in Finnland:

Gemäß den Vorschriften in Finnland kann dieses Gerät nur auf bestimmten Kanälen betrieben werden (zulässige Kanäle angeben).

Der Gebrauch dieses Geräts unterliegt einer entsprechenden Lizenz von der nationalen Frequenzverwaltungsbehörde.

Merknad for kundene i Finland:

I henhold til finske forskrifter kan dette utstyret kun brukes i kanal (angi hvilke kanaler som er tillatt).

Bruken av dette utstyret er underlagt en spesiell lisens som utstedes av nasjonale frekvensforvaltningsmyndigheter.

Remarque pour les clients résidant en Finlande

Conformément à la réglementation finlandaise, cet équipement fonctionne uniquement avec des canaux (spécifiez les canaux autorisés).

L'utilisation de cet équipement est soumise à la licence individuelle accordée par les autorités d'administration des fréquences nationales.

Opmerking voor klanten in Finland:

Volgens de Finse wetgeving mag deze apparatuur alleen werken in kanalen (opgeven welke kanalen zijn toegestaan). Het gebruik van deze apparatuur is onderhevig aan een afzonderlijke licentie die is verleend door de nationale autoriteit voor frequentiebeheer.

Bemærkning til kunder i Finland:

I henhold til finsk lovgivning kan dette udstyr kun fungere i kanaler (angiv, hvilke kanaler, der er tilladt).

Brugen af dette udstyr er underlagt individuel licens givet af telemyndighederne.

Nota per i clienti in Finlandia:

In base alle norme vigenti in Finlandia, il presente apparecchio può essere utilizzato solo su canali (specificare i canali consentiti).

L'uso di questo apparecchio è soggetto ad una licenza individuale accordata dall'Autorità per l'amministrazione delle frequenze nazionali.

För kunder i Finland:

Enligt finsk lagstiftning får den här utrustningen endast användas med följande kanaler (ange vilka kanaler som är tillåtna). Användandet av den här utrustningen sker under enskilda licenser som utfärdas av den

nationella myndighet som handhar frekvenstillstånd.

Ilmoitus suomalaisille kuluttajille:

Suomessa voimassa olevien määräysten mukaan tätä laitetta saa käyttää ainoastaan kanavilla (ilmoita sallitut kanavat).

Laitteiston käyttöön tarvitaan Viestintäviraston myöntämä henkilökohtainen lupa.

Athugasemd fyrir viðskiptavin í Finnlandi:

Samkvæmt finnskum reglum má aðeins nota þennan búnað á rásum (tilgreinið leyfilegar rásir).

Notkun þessa búnaðar þarf að vera samkvæmt leyfi frá fjarskiptayfirvöldum.

Finlandiya'daki müşteriler için not:

Finlandiya mevzuatlarına göre, bu cihaz yalnızca (izin verilen kanalları belirtin) kanallarda çalışabilir.

Bu cihazın kullanımı, Ulusal Frekans Yönetimi Makamı tarafından verilen bireysel lisansa tabidir.

Note for customer in Iceland:

The use of this equipment is subject to individual license granted by the National Frequency Administration Authority.

Hinweis für Kunden in Island:

Der Gebrauch dieses Geräts unterliegt einer entsprechenden Lizenz von der nationalen Frequenzverwaltungsbehörde.

Merknad for kundene på Island:

Bruken av dette utstyret er underlagt en spesiell lisens som utstedes av nasjonale frekvensforvaltningsmyndigheter.

Remarque pour les clients résidant en Islande:

L'utilisation de cet équipement est soumise à la licence individuelle accordée par les autorités d'administration des fréquences nationales.

Opmerking voor klanten in IJsland:

Het gebruik van deze apparatuur is onderhevig aan een afzonderlijke licentie die is verleend door de nationale autoriteit voor frequentiebeheer.

Bemærkning til kunder i Island:

Brugen af dette udstyr er underlagt individuel licens givet af teledirektoraterne.

Nota per i clienti in Islanda:

L'uso di questo apparecchio è soggetto ad una licenza individuale accordata dall'Autorità per l'amministrazione delle frequenze nazionali.

För kunder i Island:

Användandet av den här utrustningen sker under enskilda licenser som utfärdas av den nationella myndighet som handhar frekvenstillstånd.

Ilmoitus Islannissa asuville asiakkaille:

Laitteiston käyttöön tarvitaan paikallisen viestintäviranomaisen myöntämä henkilökohtainen lupa.

Athugasemd fyrir viðskiptavin á Íslandi:

Notkun þessa búnaðar þarf að vera samkvæmt leyfi frá fjarskiptayfirvöldum.

İzlanda'daki müşteriler için not:

Bu cihazın kullanımı, Ulusal Frekans Yönetimi Makamı tarafından verilen bireysel lisansa tabidir.

Table of Contents

Features	20	Setting the encrypted transmission function (ENCRYPTION)	34
Using the CD-ROM manual	21	Generating an internal signal (INTERNAL SG)	34
Preparations	21	Locking the power switch (POWER SW LOCK)	34
Reading the CD-ROM manual	21	Wireless remote control function (RF REMOTE)	35
Parts identification	22	Setting the brightness of the display (BRIGHTNESS)	35
Power supply	24	Automatic dimming of the display (DIMMER MODE)	35
Installing the batteries	24	Resetting parameters to their factory settings (FACTORY PRESET)	35
Setting the transmission channel	25	Displaying the software version (VERSION)	35
Selecting the group/channel ..	25	Attaching with the soft case	36
Using the wireless remote control function	26	Removing the clip	36
Pairing with a receiver	26	Block diagram	37
Using the encrypted transmission function	28	Troubleshooting	38
Using secure key mode (SECURE KEY)	28	Important notes on operation	40
Using password mode (PASSWORD)	29	Notes on using the transmitter	40
Using a USB keyboard	30	On cleaning	40
Basic menu operations	31	Specifications	41
Setting menus	32		
Naming of transmitter (NAME)	32		
Selecting the group/channel (GP/CH)	32		
Selecting the frequency band (BAND)	32		
Setting the RF Output Power (RF POWER)	33		
Setting the audio input level (INPUT LEVEL)	33		
Low-cut filter setting (LCF) ..	33		
Power save setting (POWER SAVE)	34		
Displaying the accumulated use time (TIME)	34		

Features

The DWT-B01 is a digital wireless transmitter for a UHF synthesized wireless microphone system to be used for broadcast or movie production purpose. This transmitter is suitable for Electronic News Gathering (ENG) and Electronic Field Production (EFP).

What are the strengths of a Digital Wireless Microphone System?

This system has the following special features and qualities:

- High-quality audio signal transmission approaching to the quality of wired microphone
- Extremely tolerant to interference waves and secure wireless transmission
- Simultaneous multi-channel operation
- Encrypted transmission
- Metadata transmission.

Note that the DWT-B01 digital wireless transmitter cannot be used to transmit to analog wireless receivers.

The features of this transmitter are described below.

Wide RF carrier frequency range

The DWT-B01 transmitter covers an extremely wide RF carrier frequency range. The U3040 and U4250 models (US models) can cover a 66-MHz band and 60-MHz band respectively — much wider than 24-MHz of the analog wireless microphone system, while the CE6267 model (European model) can cover a 48-MHz

band. This remarkably wide coverage on a single model offers cost efficiency and operational convenience, because it allows one transmitter to be operated in many different areas.

Compact, lightweight, and rugged design

The DWT-B01 is designed to be extremely compact and lightweight, essential qualities for use by artists in fast-moving TV and outdoor productions.

Switchable mic or line input level and adjustable attenuator

The audio input level of the DWT-B01 is selectable from either MIC or LINE. When MIC is selected, the attenuator can be adjusted in 3-dB steps from 0 dB to 48 dB. The reference input level of the MIC and LINE is -58 dBu (-60 dBV) and $+4$ dBu, respectively.

Selectable RF output power: 1 mW, 10 mW, and 50 mW

The 1 and 10 mW output is suitable for multi-channel operations, while the 50 mW output is intended for long-distance.

Power sleep mode

The DWT-B01 is equipped with a power sleep/wake up mode that can be wirelessly controlled from an optional digital wireless receiver.

Digital low-cut filter

Equipped with a digital low-cut filter, the DWT-B01 can reduce the effects of undesired ambient noise.

Easy-to-see, full dot-matrix OLED (Organic Light-Emitting Diode) Display

The quick response of the OLED display enables real-time operating conditions to be displayed clearly and accurately.

Using the CD-ROM manual

The supplied CD-ROM includes the Operating Instructions for the DWT-B01 (English, French, German, Italian, Spanish, and Japanese versions) and the frequency lists (English and Japanese versions) in PDF format.

Preparations

The following program must be installed on your computer in order to read the Operating Instructions contained on the CD-ROM.

- Adobe Reader Version 6.0 or higher

Memo

If Adobe Reader is not installed, you can download it from the following URL:
<http://www.adobe.com/>

Adobe and Adobe Reader are trademarks of Adobe Systems Incorporated in the United States and/or other countries.

Reading the CD-ROM manual

To read the Operating Instructions and frequency lists contained on the CD-ROM, do the following.

- 1** Insert the CD-ROM in your CD-ROM drive.

A cover page appears automatically in your browser.

If it does not appear automatically in the browser, double-click on the index.htm file on the CD-ROM.

- 2 Select and click on the Operating Instructions or the frequency lists that you want to read.

This opens the selected PDF file.

Memo

The files may not be displayed properly, depending on the version of Adobe Reader. In such a case, install the latest version you can download from the URL mentioned in “Preparations” above.

Note

If you have lost or damaged the CD-ROM, you can purchase a new one to replace it.

Parts identification

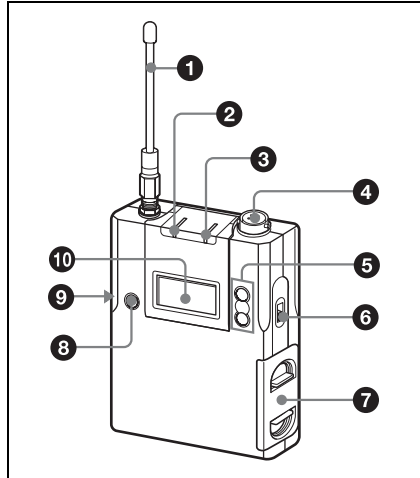

1 Antenna

2 AF (audio input level) /PEAK indicator

Lights up green when the signal input is stronger than the reference level.
Lights up red when the signal input is 3 dB below the level at which distortion begins.

3 POWER indicator

Lights up green when the transmitter is turned on. When the battery is exhausted, the indicator starts flashing.

4 Audio input connector (SMC9-4S)

Connects the output plug from the optional lavalier microphone.

This connector also accepts the input from another wired microphone connected through the supplied microphone cable, or the audio output from a mixer, etc.



- 1:+5V (OUTPUT)
- 2:Hot
- 3:Cold
- 4:GND

To connect a microphone

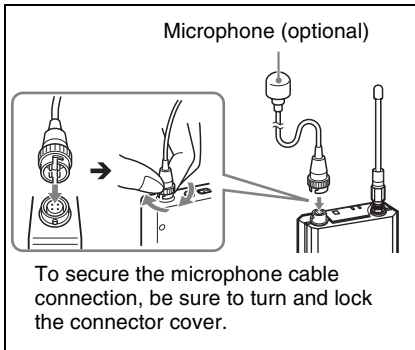

To secure the microphone cable connection, be sure to turn and lock the connector cover.

5 + or – button

Selects functions or values shown on the display.

Holding down the – button while switching on the transmitter activates the pairing operation for the wireless remote control function.

6 POWER switch

Turns the transmitter ON or OFF.

7 Battery compartment

Accommodates two LR6 (size AA) alkaline batteries.

For details on how to insert the batteries, see “Power supply” on page 24.

8 SET button

Adjusts displayed function settings and enters the value.

Holding down the SET button while switching on the power turns the transmitter on without sending a signal.

9 USB connector (Micro USB)

Use this connector to connect an optional USB keyboard to carry out menu functions

using key operations. By connecting the digital wireless receiver to this connector with the supplied USB cable, you can exchange the encryption key for encrypted transmission function.

10 Display section

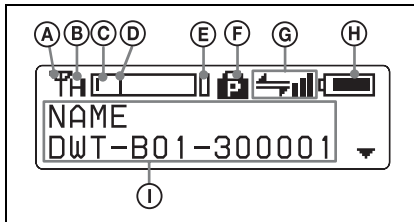

A RF transmission indication

Indicates the current transmission status.

☐: Currently transmitting

—: Transmission stopped

B RF (radio frequency) transmission power indication

Indicates the current transmission power setting. You can change the setting with the RF transmission power setting function.

H: transmitting at 50 mW

M: transmitting at 10 mW

L: transmitting at 1 mW

C Audio input level meter

Indicates the input signal level of the audio input connector

D Reference level gauge

Indicates the reference input level. When the attenuation is 0 dB with the input level set to “mic”, –58 dBu (–60 dBV) is indicated. When the line level is set, +4 dBu is indicated.

E Peak indicator

Warns of excessive input by lighting up when the signal is 3 dB below the level at which distortion begins.

ⓕ Power switch lock indicator

Indicates that the power switch is locked, preventing the transmitter from being accidentally turned off or on.

For details, see “Locking the power switch (POWER SW LOCK)” on page 34.

ⓐ Wireless remote control condition indication

Indicates the signal transmission condition of the wireless remote control function (4 levels).

📶: Good transmission

📶: Somewhat good transmission

📶: Somewhat poor transmission

📶: Poor transmission

📶: Unable to communicate with paired receiver

When the wireless remote control function is off, this indication does not appear.

ⓓ Battery indication

Shows the battery condition.

For details, see “Battery indication” on page 24.

① Menu display section

The status of 16 different functions are displayed here. To select the function, press the + or – button repeatedly.

For details, See “Setting menus” on page 32.

Power supply

The transmitter can operate on two LR6 (size AA) alkaline batteries continuously for about 3.5 hours at 25°C (77°F).

Installing the batteries

- 1 Squeeze the battery-holder tabs inward (in the direction of the arrows) and slide out the battery holder.

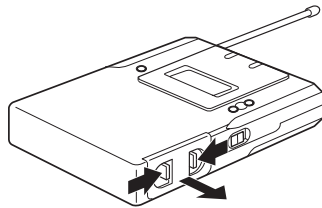

- 2 Insert new batteries, making sure the polarities are correct, and then return the battery holder to its original position.

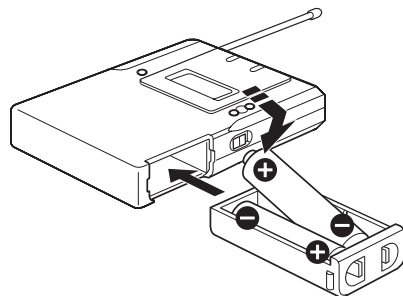

Battery indication

The power status is indicated by eight level indications.

Replace both batteries when the battery indication starts to flash.

Be sure to check the expiration date printed date on the new batteries before using them.

Note

The indication is based on the use of new LR6 (size AA) Sony Alkaline batteries. An incorrect indication may result when a different kind of batteries, a different brand of batteries or old batteries are used. If you plan to use the transmitter for a long period of time, it is recommended that you replace the batteries with brand new ones.

Setting the transmission channel

The transmitter provides groups of interference-free channels. When using multiple microphones and transmitters at the same time (simultaneous multi-channel operations) within the same area, selecting the same group and using a channel within that group can prevent signal interference. To set the transmission channel on the transmitter, first you select the group and channel using the RF indicator and scanning functions on the receiver. Next you set the group and channel parameters to match the setting on the receiver.

Selecting the group/channel

Notes

- Before doing this procedure, use the BAND function (*see page 33*) to set the transmitter to the bandwidth of the receiver you are using.
- The setting for this function cannot be changed during actual signal transmission.

Set the transmitter group (GP) and channel (CH) as follows:

For details on groups and channels, refer to “Sony Digital Wireless Microphone System Frequency Lists” on the supplied CD-ROM.

For details on menu operation, see “Basic menu operations” on page 31.

- 1 Turn off the power, and then while holding down the SET button, turn the power on.

The signal transmission stops.

- 2 Press the + or – button repeatedly until the GP/CH indication is displayed.

- 3 Hold down the SET button until the item to be set flashes.

- 4 Press the + or – button repeatedly to select a group.

- 5 Press the SET button to enter the group.

The channel indication starts flashing.

- 6 Press the + or – button repeatedly to select a channel.

- 7 Press the SET button to enter the channel.

To set the group/channel using the pairing mode of the wireless remote control function

When the transmitter is paired with the receiver, the transmission channel of the transmitter is set to the receiving channel on the receiver automatically.

For details, see “Pairing with a receiver” on page 26.

Using the wireless remote control function

This transmitter is equipped with a wireless remote control function that can be used to set the parameters (low-cut filter, attenuation operation, power save mode, etc.) of the transmitter through the receiver or other devices. This function makes it easier to operate and manage the microphone system while in the field. This wireless control is 2.4 GHz IEEE802.15.4 compliant and has no effect on the RF band of digital wireless audio. This function is activated when pairing is established between the transmitter and the receiver using the RF REMOTE function. Pairing must be done first before the wireless remote control function can be used.

Pairing with a receiver

Pairing links the transmitter with the receiver which the wireless remote control function is to be used.

When the transmitter has been paired with a receiver through the receiver operation, turning on the transmitter while holding down the – button establishes the pairing immediately.

To carry out pairing through menu operations on the transmitter, do the following.

- 1 Set the receiver to be used for controlling the transmitter to pairing mode.

For details, refer to the operating instructions supplied with the receiver.

- 2** Press the + or – button repeatedly until the RF REMOTE indication is displayed.
- 3** Hold down the SET button until the item to be set flashes.
- 4** Press the + or – button repeatedly to select PAIRING.
- 5** Press the SET button to enter.

The transmitter sends a pairing request to the receiver which is on pairing mode.

Before established pairing, if you press any operation key on the transmitter, pairing mode will be cancelled.

When pairing has been established, the wireless remote control condition level (indicated by ) goes up, RF REMOTE turns on, and the remote control function becomes operative.

To use the wireless remote control function with a previous pairing

In the RF REMOTE indication, select ON.

Notes

- When you set RF REMOTE to ON, the transmitter will communicate with the receiver to which it was previously paired. To use the wireless remote control function with another receiver, you must perform the pairing procedure for that receiver.
- Multiple transmitters cannot be paired with the same receiver.

The following transmitter settings can be done from the wireless remote control:

- Group/channel/BAND setting

- RF transmission power setting
- Attenuator for the audio input setting
- Low-cut filter setting
- Power save setting

For details on menu operation, see “Setting menus” on page 32.

To cancel the wireless remote control function

In the RF REMOTE indication, select OFF.

Notes on the wireless remote control function

The wireless remote control function on the transmitter uses the 2.4-GHz band and may thus be subject to interference from other devices.

- When pairing fails (“Pairing fail” is displayed), successful communication between the transmitter and the receiver has not occurred within a given amount of time. Pairing may be harder to do when another receiver is engaged in pairing nearby.
- When it becomes hard to use the remote control, the remote control may be improved by switching the wireless remote control function off, then on again in the RF REMOTE display, then re-pairing with the transmitter (change to a channel with less interference).

Using the encrypted transmission function

To prevent hacking of the signal, the transmitter scrambles the signal during transmission. To use this function, select one of the following encrypted transmission modes:

Secure key mode: An encryption key that is automatically generated by the transmitter is used by both the transmitter and receiver in this one-to-one encrypted transmission method.

Password mode: You choose a password of up to eight characters that can be set for multiple transmitters and receivers. This enables encrypted transmission within a group.

Note

Make sure the same mode is set on the transmitter and receiver.

Using secure key mode (SECURE KEY)

Use this mode for one-to-one encrypted transmission between one transmitter and one receiver.

An encryption key that cannot be read from the outside is automatically generated by the transmitter. This key is transmitted to the receiver through a USB connection or the RF REMOTE function, enabling encrypted transmission to take place.

The encryption key used by the transmitter and receiver is newly generated for each key transmission, resulting in highly secure communication.

The encryption key used between the transmitter and the receiver is saved when the power is turned off, so the encrypted transmission can be resumed the next time the power is turned on.

1 Preparing the transmitter (this unit)

- ① Hold down the SET button until the item to be set flashes in ENCRYPTION indication on the transmitter.
- ② Press the + or – button repeatedly to select SECURE KEY, and then press the SET button.

2 Preparing the receiver

Select SECURE KEY on the receiver that receives the encryption key.

For details on receiver operations, refer to the operating instructions supplied with the receiver.

3 Exchanging the encryption key

On the receiver, select USB or REMOTE (wireless remote) as the method for encryption key exchange. When the RF REMOTE function is off, REMOTE cannot be selected.

When you select USB:

Connect the transmitter to the receiver with the supplied USB cable and USB adapter cable.

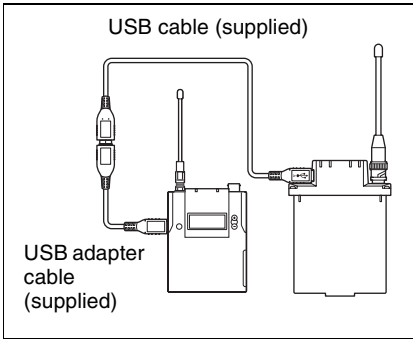

For details on receiver operations, refer to the operating instructions supplied with the receiver.

When you select REMOTE:

The transmitter searches for a receiver that it has been paired with. After the transmitter detects the receiver, the transmitter exchanges the encryption key with receiver and encrypted transmission begins.

2 Press the + or – button repeatedly to select PASSWORD, and then press the SET button.

3 Input a password of up to eight characters on the transmitter.

To enter a password, use the procedure described in “Naming of transmitter (NAME)” on page 32.

4 Set the encrypted transmission function setting on the receiver to PASSWORD.

5 Set the same password that was set on the transmitter.

For details on receiver operations, refer to the operating instructions supplied with the receiver.

Note

It is recommended that you change the password periodically.

Using password mode (PASSWORD)

Set this mode when multiple transmitters are paired with multiple receivers for encrypted transmission.

If both transmitters and receivers are set with the same user-designated password, the audio signal can be decoded. This mode is useful when multiple transmitters and receivers are used as a single group, or when the audio signal from one transmitter is received by multiple receivers at the same time.

1 Hold down the SET button until the item to be set flashes in the ENCRYPTION indication on the transmitter.

Using a USB keyboard

Connecting an optional USB keyboard to the transmitter allows you to perform menu operations and enter your name and password for the encrypted transmission function from the keyboard.

A Micro USB connector is used on the transmitter. For this reason, use the supplied USB adapter cable.

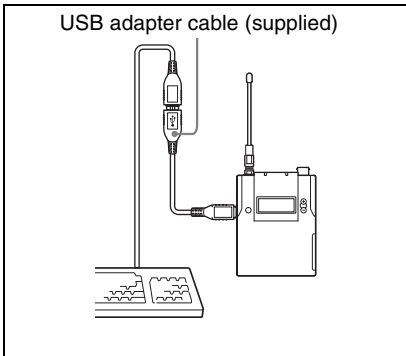

Menu operations with a USB keyboard

You can use a USB keyboard to perform the same menu operations that you do on the transmitter.

The transmitter buttons correspond to the following keys on a USB keyboard:

Buttons on the transmitter	USB keyboard
SET	ENTER
+	↑
-	↓

To enter a text

With a USB keyboard, you can enter names and passwords for encrypted transmissions.

Characters that can be entered from a USB keyboard: (space), 0, 1, 2, 3, 4, 5, 6, 7, 8, 9, A, B, C, D, E, F, G, H, I, J, K, L, M, N, O, P, Q, R, S, T, U, V, W, X, Y, Z, !, #, &, \$, @, +, -, =, _, (,), [,]

(Passwords may consist of the numbers 0 to 9 and letters A to Z only.)

Special key: Backspace (BS) and Delete (DEL) keys.

Notes

- The number keys on the keyboard cannot be used.
- This transmitter is compatible with English-language keyboards only.
- USB keyboards with multiple functions, such as USB hub and pointing device, cannot be used.
- Power to the connected keyboard is supplied by the USB connector on the transmitter. The power rating is 100 mA. Keyboards that consume more power than that cannot be used.
- Do not leave the transmitter connected to the keyboard when not in use. If you do, the batteries in the transmitter will be drained more quickly.
- Text editing should be done with the alphabet, BS, DEL, and Enter keys.

Basic menu operations

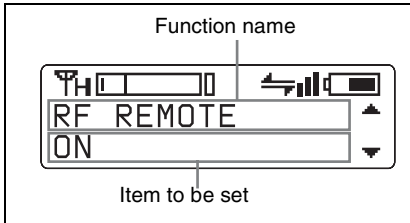

- BRIGHTNESS (display brightness) setting
- DIMMER MODE (automatic dimming of the display) setting
- FACTORY PRESET (factory setting) function
- VERSION (software version) indication

- 1** Press the + or – button repeatedly until the function to be set appears.
- 2** Hold down the SET button until the item to be set flashes.
- 3** Press the + or – button to change the setting.
- 4** Press the SET button to enter the setting.

Types of menu:

- NAME (transmitter name) setting
- BAND (frequency band) selection
- GP/CH (group/channel) selection
- RF POWER (RF transmission power) setting
- INPUT LEVEL (audio input level) setting
- LCF (low-cut filter) setting
- POWER SAVE setting
- TIME (accumulated use time) indication
- ENCRYPTION (encrypted transmission function) setting
- INTERNAL SG (internal signal generator)
- POWER SW LOCK (power switch lock) function
- RF REMOTE (wireless remote control) function

Setting menus

The functions and parameters of the settings menu are explained here. Underlined items are the factory setting.

Naming of transmitter (NAME)

You can specify a transmitter name of up to 16 characters. The factory setting for the transmitter name is the model name and serial number. The transmitter name is sent to the receiver as metadata and is used by the receiver to distinguish between different transmitters.

+: The first press on the + button displays the character set. You can then use the + and – buttons to select the desired character. And then, pressing the SET button adds the selected character to the end of the current name.

–: Deletes the last character in the current name.

SET: Enters the character or edited name.

Note

You cannot insert or delete a character in the middle of the name.

To edit with a keyboard

You can enter data from an optional keyboard connected to the USB connector.

For details, see “Using a USB keyboard” on page 30.

Selecting the group/channel (GP/CH)

The factory settings are as follows:

US models

U3040: 00 3001 566.125MHz

U4250: 00 4201 638.125MHz

European model

CE6267: 00 6201 798.125MHz

For details, see “Selecting the group/channel” on page 25.

Selecting the frequency band (BAND)

Matches the frequency range on this transmitter to that of the Sony digital wireless receiver.

The frequency range that can be set for the optional receiver combined with this transmitter differs as follows:

US models

3040U

TV30-33, TV34-36, TV38-41

Not available for TV37

4250U

TV42-45, TV46-49, TV50-51

European model

6267CE

TV62-64, TV67-69

Not available for TV65 and TV66

For details about the frequency range of each band, refer to “Sony Digital Wireless Microphone System Frequency Lists” on the supplied CD-ROM.

Note

The setting for this function cannot be changed during actual signal transmission. To change the setting, turn off the transmitter first. Then, while holding down

the SET button, turn the power on. Then change the setting after the signal transmission has stopped.

Setting the RF Output Power (RF POWER)

You can set the RF output power.

1 mW (LOW): transmitted by 1 mW

10 mW (MID): transmitted by 10 mW

50 mW (HIGH): transmitted by 50 mW

Using wireless remote control, this function can be controlled from the receiver and other devices.

Note

The setting for this function cannot be changed during actual signal transmission. To change the setting, turn off the

transmitter first. Then, while holding down the SET button, turn the power on. And then, change the setting after the signal transmission has stopped.

Setting the audio input level (INPUT LEVEL)

You can set the input level to an analog head amp.

Select LINE or MIC, depending on the audio source connected to the audio input connector.

When MIC is selected, the ATT (attenuation) level will flash next. With the microphone connected, speak into the microphone as you monitor the input level meter and press the + or – button repeatedly to select the appropriate attenuation level. The reference levels for the various settings are as follows:

Input	Attenuation (dB)	Reference input level (dB)	Maximum input level (dBu)	Headroom (dB)
MIC	0	-58	-22	36
	3	-55	-19	
	6	-52	-16	
	9	-49	-13	
	3 dB step	3 dB step	3 dB step	
	45	-13	+23	
	48	-10	+24	34
LINE	–	+4	+24	20

With the wireless remote control function, the attenuation level can be changed from the receiver and other devices.

Low-cut filter setting (LCF)

The frequency of the low-cut filter can be set.

**20 30 40 50 60 70 80 90 100
120 140 160 180 200 220 (Hz):**

Low-cut filter is set according to the selected frequency.

OFF: Turns off the low-cut filter.

Using wireless remote control, this function can be controlled from the receiver and other devices.

Power save setting (POWER SAVE)

To conserve power, this setting allows you to put all transmitter functions to sleep.

ACTIVE: The transmitter operates normally.

SLEEP: The sleep function is on. During sleep, the POWER indicator flashes at 2-second intervals.

To change back to normal operation

During sleep, press the SET, +, or – button.

You can also use the wireless remote control to change the receiver back to normal operation.

For details on wireless remote control function, see “Using the wireless remote control function” on page 26.

Displaying the accumulated use time (TIME)

You can display the accumulated battery use time as a rough estimate of total transmitter usage.

The factory setting is “00:00”.

To reset the accumulated time indication

- 1 Hold down the SET button until the time indication flashes.
- 2 Press the – button so “00:00 RESET” appears, and then press the SET button.

Setting the encrypted transmission function (ENCRYPTION)

You can set the encrypted transmission function.

SECURE KEY: Sets the secure key method.

PASSWORD: Sets the password method.

OFF: The encrypted transmission function is not used.

For details, see “Using the encrypted transmission function” on page 28.

Generating an internal signal (INTERNAL SG)

This transmitter generates a 1-kHz reference level sine wave that can be used to adjust or check the audio level of the receiver or the system that you are using. This internal signal is outside the control of the attenuator.

1 kHz: A 1-kHz internal signal is generated.

OFF: An internal signal is not generated.

Note

If the transmitter is turned off while the reference signal function is on, the function will turn off automatically.

Locking the power switch (POWER SW LOCK)

The power switch can be locked to prevent the transmitter from being accidentally turned off or on.

Even when the power switch is locked, all parts of the transmitter other than the power switch remain functional.

UNLOCK: The power switch is not locked.

LOCK: The power switch is locked. When LOCK is selected, the power switch lock icon appears in the display.

Wireless remote control function (RF REMOTE)

This function must be set to allow the wireless remote control function to be used between the transmitter and receiver.

OFF: Stops the wireless remote control function.

ON: Starts the wireless remote control function with the previously paired receiver.

PAIRING: Executes a new pairing.

For details, see “Pairing with a receiver” on page 26.

Setting the brightness of the display (BRIGHTNESS)

Ten levels of brightness can be selected for the organic light-emitting diode display. The selectable settings are the following: (Dark) **1 2 3 4 5 6 7 8 9 10** (Bright)

Automatic dimming of the display (DIMMER MODE)

The organic light-emitting diode display can be set to dim or turn off after a certain amount of time.

AUTO OFF: The display turns off after 30 seconds. The display goes on again when you press the SET, +, or – button.

AUTO DIMMER: The display dims after 30 seconds. The display becomes bright again when you press the SET, +, or – button.

ALWAYS ON: The display stays on at the brightness level set with the BRIGHTNESS function.

Resetting parameters to their factory settings (FACTORY PRESET)

All parameter settings can be returned to their factory settings.

Holding down the SET button until a message appears asking for confirmation. Press the + or – button repeatedly to select YES, and then press the SET button to enter. The transmitter parameters are reset to their factory settings.

Note

The setting for this function cannot be changed during actual signal transmission. To change the setting, turn off the power first. Then while holding down the SET button, turn the power on. Then change the setting after the signal transmission has stopped.

Displaying the software version (VERSION)

The version of the transmitter software can be displayed.

Attaching with the soft case

The transmitter can be attached to the user with the supplied soft case.

All operations are possible when the transmitter is attached with the soft case.

The clip can be attached to the soft case at an angle of 0, 90, 180, or 270 degrees, allowing you to attach the transmitter in a variety of positions.

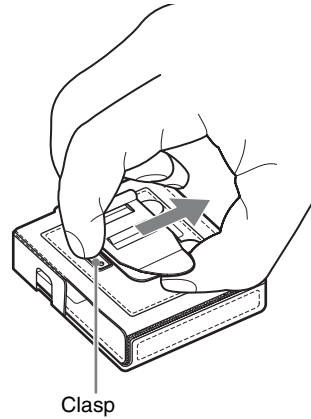

Removing the clip

Remove the transmitter from the soft case before attaching or removing the supplied clip.

- 1** Remove the transmitter from the soft case.
- 2** Insert your fingers between the clip and the soft case as shown in the illustration and pull the clip in the direction of the arrow.

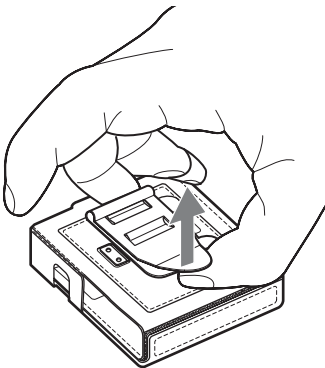

- 3** Press down on the clasp as shown in the illustration and slide the clip in the direction of the arrow.

Block diagram

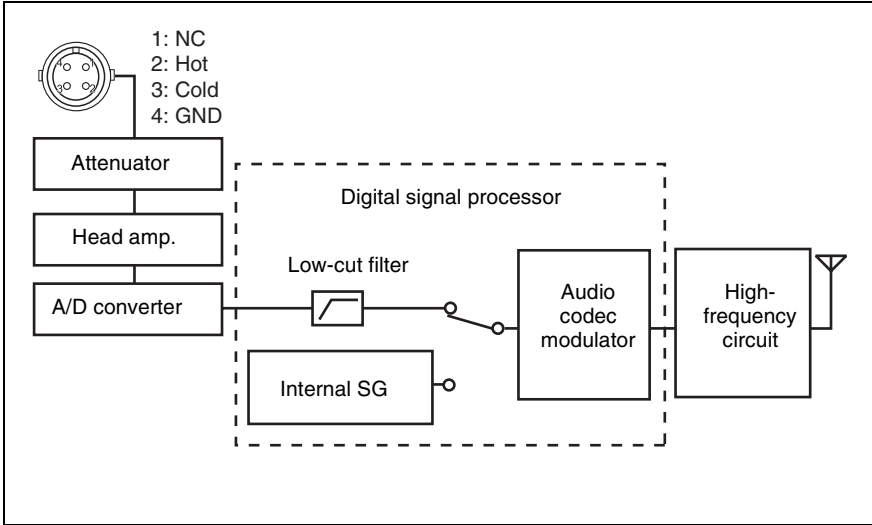

Troubleshooting

If you encounter a problem using this transmitter, use the following checklist to find a solution. For any problems with the receiver or adapter, refer to the operating instructions supplied with the respective device. If the problem persists, consult your Sony dealer.

Symptom	Meanings	Remedy
The transmitter does not turn on.	The batteries are inserted backwards in the battery compartment.	Reinsert the batteries with the correct orientation.
	The batteries are exhausted.	Replace the batteries with new ones.
The batteries drain quickly.	Manganese batteries are being used.	Use alkaline batteries.
	The transmitter is being used under cold conditions.	The batteries drain quickly under cold conditions.
Interruptions in the reception occurs.	The transmitter is too far from the receiver.	Decrease the distance to the receiver and check the reception.
	The transmission power setting is set to "L: 1mW".	Increase the transmission power.
There is no sound.	The channel setting on the transmitter is different from that on the receiver.	Use the same channel setting on both the transmitter and receiver.
	The setting of the encrypted transmission function on the receiver is different from that on the transmitter.	Confirm that the setting of the encrypted transmission function is the same on both the transmitter and the receiver.
The sound is weak.	The audio input level of the transmitter is set to LINE or the attenuation level is too high.	If a microphone is connected to the transmitter, set the audio input to MIC. While monitoring the audio input level meter, set the attenuator to an appropriate level.
There is distortion in the sound.	The attenuator is set too low for the audio input level of the transmitter.	While monitoring the audio input level meter, set the attenuator to a level that does not produce distortion.
The bass is weak.	The frequency of the low-cut filter is set too high.	While monitoring the sound, decrease the low-cut filter frequency to a level that produces the proper sound quality.

Symptom	Meanings	Remedy
There is too much bass.	The microphone connected to the transmitter produces excessive bass because the frequency response of the transmitter extends into the low 20-Hz range.	Use the low-cut filter to cut the bass.
The power does not turn off even though the power switch is turned to OFF.	The power switch is locked.	Turn off the POWER SW LOCK function.
Wireless remote control is not possible.	Pairing has not been established between the transmitter and receiver.	Carry out pairing (see page 26).
	The receiver is too far from the transmitter for communication to occur.	Check the wireless remote control condition level. If it is low, decrease the distance between the transmitter and the receiver.
	The transmitter that was paired with the receiver has been paired with another receiver.	On the receiver, carry out pairing again with the transmitter that you want to control.
The USB keyboard does not work.	You are using a USB keyboard that is not compatible with the transmitter.	Check the conditions for using a USB keyboard with the transmitter (see page 30).
The display is too dark.	The display brightness is set to low.	Adjust the brightness of the display (see page 35).

Important notes on operation

Notes on using the transmitter

- The digital wireless microphone system product must be used within a temperature range of 0°C to 50°C (32°F to 122°F).
- Operating the transmitter near electrical equipment (motors, transformers, or dimmers) may cause it to be affected by electromagnetic induction. Keep the transmitter as far from such equipment as possible.
- The presence of the lighting equipment may produce electrical interference over the entire frequency range. Position the transmitter so that interference is minimized.
- To avoid degradation of the signal-to-noise ratio, do not use the transmitter in noisy places or in locations subject to vibration, such as the following:
 - near electrical equipment, such as motors, transformers or dimmers
 - near air conditioning equipment or places subject to direct air flow from an air conditioner
 - near public address loudspeakers
 - where adjacent equipment might knock against the tunerKeep the transmitter as far from such equipment as possible or use buffering material.

On cleaning

- If the transmitter is used in a very humid or dusty place or in a place subject to an active gas, clean its surface as well as the connectors with a dry, soft cloth soon

after use. Lengthy use of the transmitter in such places or not cleaning it after its use in such places may shorten its life.

- Clean the surface and the connectors of the transmitter with a dry, soft cloth. Never use thinner, benzene, alcohol or any other chemicals, since these may mar the finish.

Notes on simultaneous multi-channel operation

- Keep the transmitter at least 30 centimeters (11 ⁷/₈ inches) away from another transmitter.
- When only digital wireless microphones are being used, keep the transmitter at least 4 meters (13 feet) away from the antenna of a receiver for up to 10 channels, and at least 6 meters (20 feet) away for 11 or more channels.
- When a mixture of digital and analog wireless microphones is being used, keep the transmitter at least 6 meters (20 feet) away from the antenna of a receiver.
- This system should be kept at least 100 meters (328 feet) away from any analog wireless systems using the same frequency when both are being used in a wide area with no walls or obstructions.
- If you experience noise, increase the distance between the transmitter and receiver or decrease the transmission power on the transmitter.

Note on microphone and transmitter combinations

It is recommended that you use the ECM-77BC/9X Sony lavalier microphone with this transmitter. The transmission signal may cause noise on some microphones. If you experience noise, you may be able to reduce it by changing the position of the microphone cable, moving the microphone

connection away from the antenna, or lowering the transmission power.

To prevent electromagnetic interference from portable communication devices

The use of portable telephones and other communication devices near the DWT-B01 may result in malfunction and interference with audio signals. It is recommended that portable communication devices near the DWT-B01 be turned off.

Specifications

Transmitting section

Oscillator type

Crystal-controlled PLL synthesizer

Carrier frequencies

US models:

U3040: 566 to 607 MHz (TV-30 to TV-36 channels); 615 to 638 MHz (TV-38 to TV-41 channels)

U4250: 638 to 698 MHz (TV-42 to TV-51 channels)

European model:

CE6267: 798 to 822 MHz (TV-62 to TV-64 channels); 838 to 862 MHz (TV-67 to TV-69 channels)

Channel step

US models:

U3040/U4250: 125 kHz

European model:

CE6267: 25 kHz

RF power output

1 mW/10 mW/50 mW (e.r.p)
selectable

Antenna type

$\lambda/4$ flexible wire

Occupied RF bandwidth

192 kHz or less

Audio delay

1.5 ms

Transmission frequency stability level

± 6.5 ppm

Type of emission

G1E or G1D

Modulation method

$\pi/4$ Shift QPSK

Audio section

Maximum input level

MIC: -22 dBu (with 0 dB attenuator)
 LINE: +24 dBu
 Audio attenuator adjustment range (pad)
 0 to 48 dB (3dB steps, MIC input mode only)
 Microphone input connector
 Sony 4-pin (SMC9-4S) (female)
 Input impedance
 4.7 kohms or more
 Frequency response
 20 Hz to 22 kHz
 T.H.D 0.03% or less
 Dynamic range
 106 dB or more

0 dBu = 0.775 V

General

Operating voltage
 3 V DC, with two LR6 (AA) alkaline batteries
 Battery life
 Continuous operating time
 3.5 hours (at 25 °C (77 °F), 10-mW output using Sony LR6 (AA)-size alkaline batteries with the wireless remote control function off and the display set to AUTO OFF)
 Operating temperature
 0 to 50 °C (32 to 122 °F)
 Storage temperature
 -20 to +60 °C (-4 to +140 °F)
 Wireless remote control
 2.4-GHz IEEE802.15.4 compliant

Dimensions (unit: mm (inches))

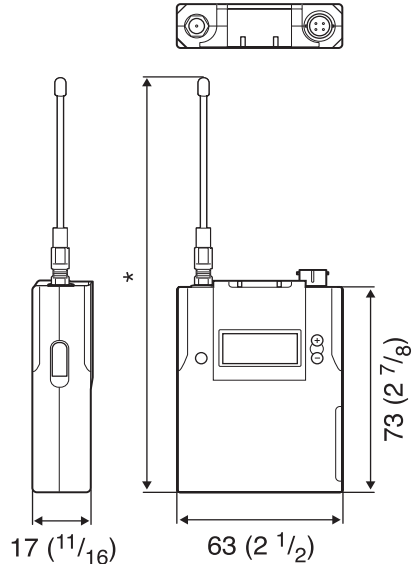

* CE6267 model: 169 (6 ³/₄)
 3040U model: 206 (8 ¹/₈)
 4250U model: 188 (7 ¹/₂)

Mass Approx. 125 g (4 oz) including batteries
 Supplied accessories
 Spare battery case (1)
 Soft case (1)
 Microphone cable (4-pin to XLR-type 3-pin) (1)
 USB adapter cable (1)
 USB cable (1)
 Carrying case (1)
 Scribble sheet (1)
 Operating Instructions (1)
 CD-ROM (1)
 Optional accessories
 ECM-77BC/9X lavalier microphones

Design and specifications are subject to change without notice.

Note

Always verify that the unit is operating properly before use. SONY WILL NOT BE LIABLE FOR DAMAGES OF ANY KIND INCLUDING, BUT NOT LIMITED TO, COMPENSATION OR REIMBURSEMENT ON ACCOUNT OF THE LOSS OF PRESENT OR PROSPECTIVE PROFITS DUE TO FAILURE OF THIS UNIT, EITHER DURING THE WARRANTY PERIOD OR AFTER EXPIRATION OF THE WARRANTY, OR FOR ANY OTHER REASON WHATSOEVER.



Printed on recycled paper.

<http://www.sony.net/>

Sony Corporation
Printed in Japan
