

# VinylJet 36™

## Printer Reference Guide

Text P/N 219476-1

Copyright © Eastman Kodak Company, 2002

NOVAJET®, KODAK®, ENCAD®, CadJet®, Extreme Color Printing™, VinylJet™, and Quality Imaging Supplies™ are trademarks of Eastman Kodak Company.

Other trademarks are the property of their respective owners.

Except as provided below, no part of this manual may be copied or distributed, transmitted, transcribed, stored in a retrieval system, or translated in any human or computing language, in any form or by any means, electronic, mechanical, magnetic or otherwise, or disclosed to a third party without the express written permission of Encad, Inc., 6059 Cornerstone Court West, San Diego, CA 92121, U.S.A.

Certain manuals are distributed by Eastman Kodak Company in an electronic format on CD-ROM or over the internet. The registered user of a KODAK or ENCAD product whose manuals are distributed in this fashion may print one copy for their personal use only.

### Revision History

Beta September 6, 2002

---

## WARRANTY CLAIMS

### United States

ENCAD warrants its printers (“PRODUCT”) to be free from defects in workmanship and materials for a period of one year from the date of purchase. In order to submit a Warranty claim, please contact the ENCAD Help Desk at (858) 452-4350.

ENCAD reserves the right to make changes or improvements to Products, without incurring any obligation to similarly alter Products previously purchased.

Buyer’s sole and exclusive rights pursuant to this Warranty shall be for the repair or replacement of defective Product. ENCAD specifically disclaims any and all other warranties, expressed or implied, including but not limited to, implied warranties of merchantability and fitness for a particular purpose. In no event shall ENCAD be liable for any loss of profit or other commercial damages, special, incidental or consequential damages, or any other damages or claims, whatsoever.

This Warranty gives Buyer specific legal rights, and Buyer may also have other rights that vary from state to state.

This Warranty applies only to printers purchased from ENCAD, or authorized ENCAD distributors or dealers. The intent of this Warranty is to repair or replace defective Products subjected to normal wear and tear, when operated according to ENCAD instructions.

#### **This warranty does not cover damage to the Product resulting from the following:**

- **Accident or negligence.**
- **Unauthorized modification of the Product.**
- **Adverse environmental conditions.**
- **Service of the Product by other than an ENCAD authorized service provider.**
- **Unauthorized or improper use, including but not limited to:**
  - **Use in applications for which the Product was not designed.**
  - **Using cartridges or ink other than those supplied by ENCAD.**
  - **Lubricating any part of the printer.**

Internationally: Contact your dealer or distributor for warranty information.

Extended Warranty: An extended warranty is available for your ENCAD printer. Contact your dealer/distributor or ENCAD for further details.

---

## FCC Statement (U.S.A.)

The United States Federal Communications Commission has specified that the following notice be brought to the attention of users of ENCAD printers.

FEDERAL COMMUNICATIONS COMMISSION RADIO AND TELEVISION INTERFERENCE FOR CLASS A DEVICE

### Statement

This equipment has been tested and found to comply with the limits for a Class A digital device, pursuant to Part 15 of the FCC Rules. These limits are designed to provide reasonable protection against harmful interference in a residential installation. This equipment generates, uses, and can radiate radio frequency energy, and if not installed and used in accordance with the instructions, may cause harmful interference to radio communications.

### User Instructions:

If the equipment does cause harmful interference to radio or television reception, which can be determined by turning the equipment on and off, the user is encouraged to try to correct the interference by one of the following measures:

- Reorient or relocate the receiving antenna.
- Increase the separation between the equipment and receiver.
- Connect the equipment into an outlet on a circuit different from that to which the receiver is connected.
- Consult the dealer or an experienced radio/TV technician for help.

Changes or modifications not expressly approved by ENCAD could void the user's authority to operate the equipment.

Note: This product was FCC certified under test conditions that included the use of shielded I/O cables and connectors between system components. To be in compliance with FCC regulations, the user must use shielded cables and connectors and install them properly.

## VDE statement

Hiermit wird bescheinigt, daß der Drucker in Übereinstimmung mit den Bestimmungen der BMPT-AmstbIVfg 234/1991 funktentstört ist. Der vorschriftsmäßige Betrieb mancher Geräte (z.B. Meßsender) kann allerdings gewissen Einschränkungen unterliegen. Beachten Sie deshalb die Hinweise in der Bedienungsanleitung.

Dem Zentralamt für Zulassungen im Fernmeldewesen würde den Inverkehrbringen dieses Gerätes angezeigt und die Berechtigung zur Überprüfung der Serie auf die Einhaltung der Bestimmungen eingeräumt.

## Industry Canada

This Class A digital apparatus meets all requirements of the Canadian Interference-Causing Equipment Regulations.

Cet appareil numérique de la classe A respecte toutes les exigences du Règlement sur le matériel brouilleur du Canada.

## Material safety data sheet

To obtain information on the proper use, handling, and disposal of any ENCAD AquaVinyl (AV) ink, consult the material safety data sheet included in the ink kit or obtain a copy from ENCAD at:

6059 Cornerstone Court West  
San Diego, California 92121-3734  
(858) 452-4350

International users should contact their local dealer or distributors.

## General operating safety

The use of a <HAR> cord set (rated 10A, 250VAC) with the proper plug configuration for the country where the device will be used, is required for continued safety compliance.

Ein harmonisiertes (<HAR>) Netzkabel (min. 10A, 250V~) mit dem vorgeschriebenen Netzstecker für das entsprechende Land in dem das Gerät installiert wird, ist unbedingt notwendig für die elektrische Sicherheit.

El uso de cable poder <marcado HAR> (capacidad de 10A, 250V~), con el enchufe apropiado para el país donde se use el producto, es requerido para acatamiento de seguridad eléctrica.

L'emploi d'un cordon surmoulé <HAR> (estimé 10A, 250V CA) avec la configuration de la fiche convenable pour le pays où l'appareil sera utilisé, est exigé pour la conformité à la sécurité continuée.

---

## For your safety

This section provides safety guidelines. Test results indicate safe Federal agencies emissions levels per OSHA-PEL and ACGIH-TLV.



Vapors may arise from the printer during printing. For additional information, and for information on proper disposal of materials, refer to the Materials Safety Data Sheet.



Always unplug the printer before servicing it.



**Proper room ventilation and housekeeping are required.** This is accomplished by providing fresh air circulation into the room, not necessarily by a filtration and/or external ventilation device.



“Vapors” which arise during printing may adhere to certain surfaces. Please be sure to clean any residue with soap and water to keep your working area clean and safe.



Use vinyl/PVC media only.



Keep hands, hair, and clothing away from the infrared (IR) lamp.



If you are operating the printer within the state of California, to comply with California Proposition 65, the “Proposition 65” placard provided with your printer must be posted.





Media must be attached to the takeup roll when printing.



Do not leave printer unattended.

## Manual conventions

-  Indicates a procedure for you to follow in order to perform a specific function. Read the accompanying explanatory text before following the step-by-step procedure.
-  Indicates a warning. Ignoring the warning can damage the printer or result in an unsatisfactorily printed image.
-  Indicates a tip or suggestion that can make using the printer easier or improve your printed images.

## Other reference materials

In addition to this guide, the following additional documentation is included with your printer:

**Quick Start Guide** - Tells you how to attach the printer stand, load media, install cartridges, and connect the printer to your computer.

**CD-ROM** - contains the following:

### **Documents**

- EFPU Guide
- Reference Manual
- Maintenance Guide
- Quality Primer

### **Applications**

- EFPU
- Windows 95/98/NT/2000/ME Drivers
- Flexibanner (Trial Version on separate CD)

### **Other**

- Demo Files

---

---

# Contents

---

<b>Chapter 1 Printer setup .....</b>	<b>1-1</b>
Printing .....	1-2
Obtaining quality results .....	1-2
Caring for your ink and cartridges .....	1-3
<b>Chapter 2 Printer options .....</b>	<b>2-1</b>
Returning to the default settings .....	2-1
Printing the settings .....	2-1
Important notes about image size vs. dpi .....	2-1
Color mode .....	2-2
Choosing quality mode options .....	2-2
Choosing feed media options .....	2-3
Media counter .....	2-3
Choosing paper options .....	2-4
Auto-load delay .....	2-4
Save media .....	2-5
Auto-Wipe .....	2-5
Defining user setup .....	2-5
Choosing a language .....	2-6
Choosing ink options .....	2-7
Printer default settings .....	2-9
<b>Chapter 3 Printing .....</b>	<b>3-1</b>
<b>Chapter 4 HP-GL/2.....</b>	<b>4-1</b>
CAD printing modes .....	4-1
Printing vector data .....	4-1
Accessing HP-GL/2 features .....	4-2
Palette select .....	4-2
Control .....	4-3
Rotation .....	4-3
Reprints .....	4-4
Nesting .....	4-5
Nest time .....	4-6
Ink limit .....	4-7

---

---

<b>Appendix A Installing additional memory.....</b>	<b>A-1</b>
Acceptable SIMM sizes .....	A-1
SIMM installation .....	A-1
<b>Appendix B Menu tree .....</b>	<b>B-1</b>
Main menu at a glance .....	B-1
Main menu .....	B-2
Feed media menu .....	B-2
Setup menu at a glance (Bold indicates the default) .....	B-3
Utility menu at a glance (Bold indicates the default) .....	B-4
Setup menu .....	B-5
Utility menu .....	B-8
<b>Appendix C Technical information .....</b>	<b>C-1</b>
<b>Appendix D Error messages.....</b>	<b>D-1</b>
Cartridge errors .....	D-1
<b>Appendix E Troubleshooting .....</b>	<b>E-1</b>
troubleshooting quick list .....	E-1
Isolating problems .....	E-1
Printer health .....	E-2
Data Transfer .....	E-9
Application Software .....	E-11
Calling for Help .....	E-13
Customer Technical Support .....	E-14

---



This Reference Guide describes the VinylJet 36™ printer. This chapter provides an overview of the printer. Refer to the Quick Start Guide for setup instructions.

The printer is a wide-format color inkjet printer that gives you professional-quality output on uncoated vinyl, using aqueous-based inks. Designed specifically for the needs of small sign shops, the VinylJet 36 lets you experience the value of exceptional, full color graphics on banners and signs designed for outdoor use.

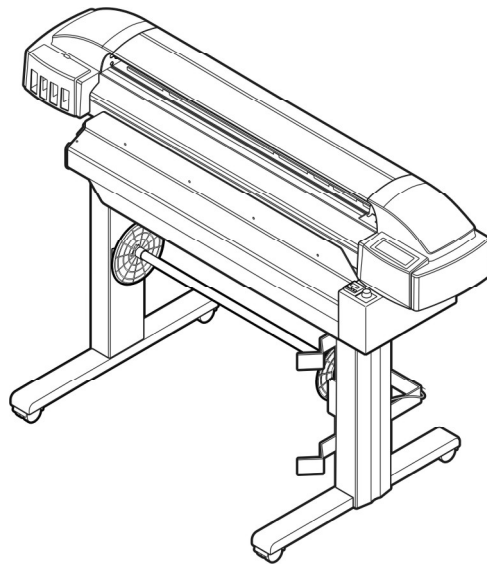

## Printing

Your printer features thermal ink cartridges with 208 jets. Reservoirs hold up to 500 ml of ink. You can print with four colors of ink (CMYK) which yield millions of colors.

The printers accept raster-oriented data in the format of HP RTL or HPGL. In this mode, printing begins immediately after the first complete line of HP RTL data is received.

There are many Raster Image Processors (RIPs) which convert Postscript or CGM to HP RTL. When choosing a RIP or a file format converter for output to the printer, make sure it has the features you need. (Contact your ENCAD distributor or dealer for an up-to-date listing.) If your applications do not support HP RTL, there are several software utilities available to convert various raster file formats (TIFF, GIF, BMP, etc.) into HP RTL.

## Obtaining quality results

You have probably seen a demonstration of your printer's capabilities or sample output. If so, you are aware of the superb color graphics which can be obtained on uncoated vinyl media. Note, however, that to obtain high-quality results, you must consider several factors. Follow the simple guidelines in the sections that follow to obtain excellent results.

## Use the right inks and media

ENCAD's commitment to Extreme Color encompasses media, ink, and cartridges. A team of color scientists and media specialists work with world class ink and media manufacturers to develop supplies that are scientifically matched to ENCAD printers.



---

## Caring for your ink and cartridges

- Handle cartridges only on the plastic areas. Touching the copper electrical interconnect or the inkjets can damage the cartridge.
- Use only AV ink intended for the VinylJet36. Do not mix inks.
- Do not shake ink refill containers.
- Store ink and cartridges in the same environment as the printer whenever possible.
- If you remove a cartridge from the printer, do not leave it exposed to the air for an extended period because the jets may clog. Replace the original tape on the jet plate. Place the cartridge in a cartridge garage or sealed plastic bag and store it in a closed area at room temperature. Keep it out of direct sunlight.
- Open new cartridges only when you are ready to install them.
- Use only ENCAD-brand ink refills and cartridges.
- Drawings containing both black and color elements require alignment of the cartridges to each other as described in the Quick Start Guide.

## Choose the right media

The VinylJet 36 is designed to print **ONLY** on uncoated vinyl media, not on paper.

## Caring for your media

Store media in its original packaging in a cool, dry area until you are ready to use it. The environment should be stable; i.e., no extremes of heat and cold, and non-condensing humidity. If conditions are outside the operating ranges recommended for the printer, allow the media to acclimate in the operating environment for at least 48 hours before using it.

If you remove a roll of media from the printer, be sure to store it in a manner which keeps it clean and dust-free. Ideally, you should return it to its original packaging for storage.

**Print on the correct side!** Roll media is wound with the printable side out.

**Handle with care!** Handle your media carefully to avoid creases, scrapes, and tears. Avoid crushing or damaging roll media edges.

## **Choose the correct printing mode**

By choosing from a variety of color, quality, and resolution modes, you can make choices between drawing quality, colors, and speed. When printing images with large areas of color, always choose one of the enhanced printing modes (Enhanced or Best).

## **Use the right software**

The quality of the software driver or the RIP can be very important, especially when printing continuous tone images. Error diffusion or stochastic screening algorithms can yield photo-like images, even when these images are scaled to full size. Software without advanced imaging features may produce images which are grainy when enlarged.

You can define printer options through your application software or by choosing settings from the printer's control panel. The following printer options are described in this chapter:

- Initialize (return to printer default settings)
- Print Mode
- Paper Options
- User Setup

## Returning to the default settings

Pressing the **Setup/User Setup /Init Settings** buttons returns all printer options to the factory defaults. All saved user settings are lost. The table at the end of this chapter shows the printer defaults.

## Printing the settings

Pressing the **Setup/User Setup/Print Settings** buttons causes the printer to print a listing of its current settings. Be sure to have media loaded before you start.

## Important notes about image size vs. dpi

The printer always prints at 600 dpi. DPI (dots per inch) refers to the resolution at which your image is created, not the resolution at which it is printed. If your image is created at 300 dpi, it will print at 1/4 the size of the original. Therefore, you will want to save it at 600 dpi before printing.

## Color mode

Color mode refers to whether you are printing in color, grayscale or monochrome.



### To choose the color mode

- 1 Press **Setup/Print Mode/Color Mode**.
- 2 Choose **Color, Mono, or Gray**.
- 3 Press OK.

## Choosing quality mode options

Your printer offers several print quality modes which let you make choices between speed and quality.

The quality mode you use depends on various factors, such as your software application and whether you're printing in color or monochrome. Each quality mode directly affects the printing speed and quality of the image you print, so you should understand the differences.

Each of the quality modes attempts to strike a balance between speed and quality, with the quality mode providing quality images at a reasonable printing speed for most users. Whenever you choose a quality mode other than Enhanced, you will choose to emphasize either speed or quality. Draft and Enhanced modes are suited for jobs with light solid fills. These modes are not recommended for printing images, because bleeding may occur in areas of heavy fills or dark shading when printed with these modes.

There are four print quality modes.

**Draft** - A 30% ink depletion mode. This mode generally is used when speed is more important than quality. Use it to check position, layout, color, etc. It will rarely be used for finished quality images.

**Enhanced** - Fast, better than average quality.

**Photo** - This setting is for fast, average quality (default)

**Best** - For images that have sections of high quality continuous tone where quality is more important than printing speed.



## To choose print quality

- 1 Press **Setup/Print Mode/Quality Mode**.
- 2 Choose the desired quality.
- 3 Press **OK**.

## Choosing feed media options

Feed media options allow you to:

- advance the media\*
- display/enter Media Counter values

\*Media feeding and loading are described in the Quick Start Guide.

## Media counter

Media Counter gives you a means of **estimating** the amount of media left on a roll. When a new roll of media, or a used roll where the remaining length is known, is installed on the printer, you can enter the length of the roll into the printer's front panel display. As the printer prints, this amount is decremented. You can view the estimated amount of media remaining on the printer's front panel display. When you are ready to remove the roll, you can print the estimated amount of media remaining on the roll. When you reload this media, you can use this figure to enter into the printer's front panel display. The media counter can be reset to 0 to avoid confusion if it is not being used. The media counter will not decrement below 0. The current value of the media counter is maintained across power cycles but is not stored as a user parameter.



## To enter a media length value

- 1 Press **Feed Media/Media Counter**.
- 2 Set the media length.
- 3 Press **OK**.



### To display the current value

- 1 Press **Feed Media/Display Counter**.
- 2 View the current value.
- 3 Press **EXIT**.



### To print the current value

- 1 Press **Feed Media/Display Counter**.
- 2 Press **Print Counter**.
- 3 Press **EXIT**.



### To reset the media counter

- 1 Press **Feed Media/Media Counter**.
- 2 Press **Reset Counter**.
- 3 Press **OK**.

## Choosing paper options

Paper options let you define the following:

- Auto-Load Delay
- Save Media
- Auto-Wipe

### Auto-load delay

Auto-Load Delay lets you set the time between when the printer senses the media and when printing starts. This lets you manually reposition the media if necessary. The default is 6 seconds, selectable from a range of 1-12 seconds.



### To set auto-load delay

- 1 Press **Setup/Paper Option/Auto-Load Delay**.
- 2 Choose the delay time.
- 3 Press **OK**.



---

## Save media

When the Save Media is On (the default), the media advances only as far as needed to print the image. With the Save Media option turned off, the printer advances the length of a standard sheet, for example, 24x36 or 36x48 inches.



### To turn off Save Media

- 1 Press **Setup/Paper Option/Save Media**.
- 2 Choose **Off**.
- 3 Press **OK**.

## Auto-Wipe

The cartridge jet plates are periodically wiped during printing. The default for this function is ON. If you are having problems with banding, you can sometimes solve the problem by setting the wiper to OFF; however, this can cause clogging of the inkjets.



### To turn off the wiper

- 1 Press **Setup/Paper Option/Auto-Wipe**.
- 2 Choose **Off**.
- 3 Press **OK**.

## Defining user setup

You can save the options you use most frequently so you don't have to reconfigure the printer each time you print an image. You can define up to eight different combinations of options and save them with a user number ranging from 1-8. Select the user number you want to use before sending an image to the printer.

**Note:** If your printer driver has host-controlled settings, the user setup may be overridden. If possible, disable the driver control settings.

You can save settings for the following options:

- Auto-Wipe On or Off
- Quality Mode
- Color Mode
- Save Media On or Off



### To save user setup

- 1 Press **Setup/User Setup/Save User**.
- 2 Scroll to the number for the user settings.
- 3 Press **OK**.



### To use a previously saved user setting

- 1 Press **Setup/User Setup/Select User**.
- 2 Scroll to the number for the user settings (i.e., user 1, user 2, etc.) to use.
- 3 Press **OK**.

## Choosing a language

Printer menus and options can be displayed in the following languages: English, German, French, Italian, Portuguese, Spanish, traditional and simplified Chinese, Japanese, and Korean.



### To choose a language

- 1 Press **Setup/User Setup/Language**.
- 2 Choose the language to display.
- 3 Press **OK**.

## Printing the settings

Pressing the **SetupMenu/User Setup Menu/Print Settings** buttons causes the printer to print a listing of its current settings and configuration. Be sure to have media loaded before you start.

## Returning to the default settings

Pressing the **Setup Menu/User Setup Menu/Init Settings** buttons returns all printer options to the factory defaults. All saved user settings are lost. The table at the end of this chapter shows the printer defaults.

---

## LCD contrast

The LCD Contrast function lets you adjust the brightness of the control panel. The range is 1-16, where 16 is less contrast. The default is 9. Note that if brightness is set too high, you may not be able to see the text displayed on the control panel.



### To set LCD contrast

- 1 Press Setup/User Setup/LCD Contrast.
- 2 Choose the contrast value.
- 3 Press OK.

## Choosing ink options

Ink options let you define the following:

- Ink reduction
- Ink Preheat
- Dry EOP
- Manual EOP

## Ink reduction

Ink reduction lets you reduce the percentage of ink laid down by the printer. This feature applies only to HPGL/2 format images (vector-based images) and has no effect on continuous tone images. It is especially useful for images with large amounts of printed area and helps to avoid bleeding or oversaturating the media. It does, however, change the appearance of colors, so you may want to run a small test print.



### To set ink reduction

- 1 Press **Setup/Ink Option/Ink Reduction**.
- 2 Choose a reduction percentage - 12.5, 25%, 37.5, or 50%.
- 3 Press **OK**.

## Ink preheat

Cartridge heat settings are optimized for media being printed in a standard office environment. If you are experiencing banding, poor fills, or too much dot gain, and you have tried all other means to correct these conditions, you may want to experiment with the ink preheat settings. These will vary depending on the ambient temperature where the printer is located and the media used.

When you adjust the ink settings, you are increasing or decreasing the heat from the default temperature. Pressing the + (plus) button increases the temperature, pressing - (minus) decreases it. When you have reached the limits of the temperature range, the panel will display either MAX or OFF. These settings are saved in the printer. If you change to a different type of ink, you may need to change the heater settings to accommodate the new ink type.

Only the default setting is recommended. However, if you are working in a cold or dry environment, try turning the heat up for a larger dot size. If the heat is turned up too far, the ink may run or sputter. Settings which are too low may result in reverse ghosting. If you are working in a humid or hot environment, turn the heat down for a smaller dot size. Generally a change of one or two increments is all that is needed.



### To set the ink preheat time

- 1 Press **Setup/Ink Option/Ink Preheat**.
- 2 Choose a preheat value.
- 3 Press **OK**.

## Dry EOP

End of page dry ON enables the printer at the completion of the print job to automatically advance the media at the printing speed 12 inches to fully pass the IR heater. The media is then fed back into the printer at 25% of the normal reserve speed to avoid cockling on the retract move. End of Page dry OFF does not perform this at job completion and should be used when multiple plots are being printed.



### To set dry EOP

- 1 Press **Setup/Ink Option/EOP Dry**.
- 2 Choose On.
- 3 Press **OK**.

---

## Printer default settings

<b>USER SETTINGS</b>	<b>DEFAULT</b>	<b>OTHER OPTIONS</b>
COLOR MODE	COLOR	MONO, GRAY
QUALITY MODE	PHOTO	DRAFT, PHOTO, ENHANCED, BEST
AUTO-LOAD DELAY	6	1-12 SEC.
SAVE MEDIA	ON	OFF
CALIB XY	ON	OFF
SELECT USER	1	1 TO 8
SAVE USER	1	1 TO 8
UNITS SELECT	ENGLISH	METRIC
LANGUAGE	ENGLISH	GERMAN, FRENCH, ITALIAN, SPANISH, PORTUGUESE, JAPANESE. TRADITIONAL AND SIMPLIFIED CHINESE, KOREAN
<b>SYSTEM SETTINGS</b>	<b>DEFAULT</b>	<b>OTHER OPTIONS</b>
LCD CONTRAST	9	1-16
MEDIA COUNTER	0	1-500 FT.
DRY EOP	ON	OFF
<b>CALIBRATION SETTINGS</b>	<b>DEFAULT</b>	<b>OTHER OPTIONS</b>
DEADBAND	N/A	0...20
SLOW DEADBAND	0	-2...+2
CYAN VERTICAL	0	-9...+9
MAGENTA VERTICAL	0	-9...+9
YELLOW VERTICAL	0	-9...+9
CYAN HORIZONTAL	0	-9...+9
MAGENTA HORIZONTAL	0	-9...+9
YELLOW HORIZONTAL	0	-9...+9
PAPER AXIS	33.00	32-34

The way you print from your computer depends on the driver or RIP you have installed. Your printer comes with a Windows driver and one RIP:

- Windows driver for general use
- EFPU
- Flexibanner (trial version)

## Printing a file

The Windows driver allows you to print from virtually any Windows-based application.



### To print a file using the Windows driver

- 1 Open the file from within an application.
- 2 Choose **File/Print**.
- 3 Select your printer.
- 4 Click **Features**.
- 5 From here, **Page Setup** and **Advanced** tabs allow you to adjust printer specific options for your print file. Generally, you should only need to set paper size and orientation options.
- 6 Click **OK**, then click **OK** again to send your file to the printer.

## Notes about printing

Print only on untreated vinyl. This printer is not intended for printing on coated vinyl or other media.

This printer is not designed for unattended operation. Be sure that the media weight bar is placed on the media as shown in the Quick Start Guide. This keeps the media the correct distance from the IR bulb and helps to assure proper ink curing.

### End of Print function

The End of Print function moves the last part of a print down under the IR bulb to cure it. However, this does not work at the end of a roll. Vinyl media is taped to the core of the supply roll. Before printing, be sure there is sufficient media left on the roll to do the print and advance the entire print past the IR bulb to cure it. You can determine whether there is sufficient media by choosing **Feed Media Menu/Media Counter**.

This chapter discusses setting printing parameters generally used with vector-based files, including palette selection, printer control, rotation, reprints, nest time, nest enable, and ink limit.

ENCAD's implementation of HP-GL/2 supports vector/raster merge and conforms to "The HP-GL/2 and HP RTL Reference Guide, Third Edition" by Hewlett-Packard Company (Addison-Wesley, 1997, ISBN 0-201-31014-7). Please refer to this guide for details on HP-GL/2 commands.

## Printing modes

Your printer offers several print modes which let you make choices between speed and quality. The procedure for selecting print modes is described in Chapter 2.

The print mode you use depends on various factors, such as your drawing application, whether you're printing in color or monochrome, and what type of media you're using. Each print mode directly affects the printing speed and quality of the image you print, so you should understand the differences.

Draft or Photo modes are suited for drawings with light solid fills. These modes are not recommended for continuous tone printing images, because bleeding may occur in areas of heavy fills or dark shading when printed with these modes.

## Printing vector data

When printing vector data, you can control certain options from your software application, or you can assign control to the printer and set its options. Whether you assign control to the software (the default) or the printer depends on your personal preferences. You might choose to override software control because the software is not providing the features you want.



---

## Accessing HP-GL/2 features

The following functions are available from the HP-GL/2 menu: palette select, printer vs. software control, rotation, ink reduction (see Chapter 2), reprints, nest time, nest enable, and ink limit.



### To access HP-GL/2 features

- 1 From the main menu, choose **Setup Menu/HP-GL/2 Options**.
- 2 Press **Select**.

The HP-GL/2 Options menu displays with further options.

## Palette select

Palette select lets you choose either the HP-GL/2 or AutoCAD palette. Both palettes allow 256 active colors with eight colors predefined. The predefined colors for each palette are shown in the following table.

	HP-GL/2	AutoCAD
Pen 0	White	White
Pen 1	Black	Red
Pen 2	Red	Yellow
Pen 3	Green	Green
Pen 4	Yellow	Cyan
Pen 5	Blue	Blue
Pen 6	Magenta	Magenta
Pen 7	Cyan	Black



### To choose a palette type

- 1 From the main menu, choose **Setup menu/HP-GL/2 Options/Palette**.
- 2 Press **Select**.
- 3 Use the up or down arrow button to display either **AutoCAD** or **HP-GL/2**.
- 4 Press **Select**.

---

## Control

Control determines whether certain printing parameters are set in the software application or overridden by the printer's front panel. Control overrides the following parameters of the HP-GL/2 header file: repeat plot (RP) and enable auto cutter (EC).

**Repeat Plot:** With Control set to **Printer**, the printer will ignore RP commands in the plot file and only print one plot. From the printer's front panel you can specify additional copies using the **Reprints** menu.

**Enable Auto Cutter:** With Control set to **Printer**, the printer will ignore EC commands in the plot file and will not automatically cut after each plot. From the printer's front panel, you can enable automatic cutting or initiate a command for a single cut.

- ✓ Do not override software control when sending merged raster/vector data to the printer.



### To set control

- 1 From the main menu, choose **Setup Menu/HP-GL/2 Options/Control**.
- 2 Press **Select**.
- 3 Use the up or down arrow button to display either **Software** or **Printer**.
- 4 Press **Select**.

## Rotation

The printer automatically prints an image with the long side on the paper axis. To better fit images and save media, you can use the **Rotation** option to turn vector files counterclockwise 90 degrees at a time. If the rotation specified won't fit on the media or contains raster images, it will not be rotated. When the Rotate value is set to **AUTO**, the algorithm will automatically rotate the plot if it determines that the rotation will save media (regardless of whether **Nesting** is enabled). If **Rotate** is set to 0, the plot will not be rotated. The Control function does not override the RO command in the plot file.

**Note:** Rotation is supported for HP-GL/2 files only. It is not supported for RTL files.



### To rotate the image

- 1 From the main menu, choose **Setup Menu/HP-GL/2 Options/Rotation**.
- 2 Press **Select**.
- 3 Use the up or down arrow button to display the desired rotation angle (0, 90, 180, 270, Auto).
- 4 Press **Select**.

## Reprints

You can print up to 99 copies of a specific vector file. When **Reprint** is set to 0, only one image is printed.



### To make multiple prints

- 1 From the main menu, choose **Setup Menu/HP-GL/2 Options/Reprints**.
- 2 Press **Select**.
- 3 Use the up or down arrow button to display the desired number of reprints (0 to 99).
- 4 Press **Select**.

## Nesting

Nesting allows the user to save media by printing multiple plots along the horizontal width of the media. This feature makes the most efficient use of consumables and reduces the time required to print multiple plots.

When nesting is active, HP-GL/2 plots will be stored within the printer, accumulating in a *nest*. Printing will only begin when a nest becomes full, when a nesting timeout occurs, if printer memory is exhausted, or when a plot that is incompatible with the current nest is received.

A nest is full when the printer determines that no further jobs can be fitted across the page.

Nest timeouts are governed by the **Nest Time** parameter, which is set via the printer's front panel.

If the printer runs out of memory, the current nest will be printed immediately, so that memory may be reclaimed for use by new plots.

An incompatible plot is either a non-HP-GL/2 plot or an HP-GL/2 plot which has different job characteristics than the current nest, such as quality, dpi, or margins.

If any of the following plot parameters are different between one plot and the next, the last plot will be incompatible with the current nest, causing the nest to begin printing immediately.

The following parameters are monitored for nest compatibility:

- Print quality;
- Number of passes;
- Print direction;
- Speed;
- Color mode;
- DPI;
- Dry time;
- Margins;
- Wipe on/off; and
- Media Save.

The following parameters will not affect nesting:

- Ink limiting;
- Replots;
- If Auto Rotation is enabled, then the nesting algorithm is free to rotate the plot if it determines that doing so will save media. Plots are sequentially fitted across the page from right to left; and
- The HP-GL/2 EC command can be used to control cutting. If any plot in a nest has the cutter enabled, the plotter will cut after the nest.



### To enable nesting

- 1 From the main menu, choose **Setup Menu/HP-GL/2 Options/Nest Enable**.
- 2 Press **Select**.
- 3 Use the up or down arrow button to display **Nest On** or **Off**.
- 4 Press **Select**.

## Nest time

Nest time is the amount of time the printer waits for the next plot to fill the current nest.

The printer will begin printing whenever the printer has been idle for the specified time interval. The time is reset whenever a print job is received.



### To define nesting wait time

- 1 From the main menu, choose **Setup Menu/HP-GL/2 Options/Nest Time**.
- 2 Press **Select**.
- 3 Use the up or down arrow button to display the desired nest time.
- 4 Press **Select**.

## Ink limit

The printer can assign an ink limit to polygon fills and wide vectors. This helps prevent bleeding. The default for this option is On. If you are using high quality media, this option may not be needed and can be turned off.



### To enable the ink limit

- 1 From the main menu, choose **Setup Menu /HP-GL/2 Options/Ink Limit**.
- 2 Press **Select**.
- 3 Use the up or down arrow button to display **ON**.
- 4 Press **Select**.

The VinylJet 36 ships with 32 MB of DRAM, upgradable to a maximum of 128 MB, 64 MB per socket. Additional memory helps to free the host computer more quickly.

## Acceptable SIMM sizes

Printer memory may be upgraded by installing 72-pin 60 nanosecond (or faster) SIMMs that are either 32 or 36 bits wide. (The printer does not use parity bits.) The SIMMs must not exceed a height of 2 inches (5 cm) and must conform to JEDEC Std. 21-C, release 4.

The printer will accept 4 MB, 8 MB, 16 MB, 32 MB or 64 MB SIMMs. Recommended SIMMs are ENCAD P/N 210610 (32MB SIMM).

## SIMM installation

The SIMMs are located on the MPCB inside the right cover. The MPCB comes with one SIMM slot empty and a 32 MB RAM SIMM installed on the board. The following procedures describe how to remove the right cover, remove any currently installed SIMM(s), install new SIMM(s) and replace the cover. You will need a #2 Phillips screwdriver to complete the procedures.

**! ALWAYS UNPLUG THE POWER CORD BEFORE BEGINNING.**

**!** To avoid static damage to the printer, never touch the circuit board or its components without first touching the bright metal portions of the printer. Static damage is more likely when the relative humidity is low. If possible, wear a grounding strap when touching the circuit board.



### To remove the right cover

- 1 Disconnect the power and the interface cables.
- 2 Remove the printer's top cover.
- 3 Remove the three screws under the right side of the printer which attach the right side cover and the two screws which attach the cover to the right plate.
- 4 Slide back the pin that holds the right cover to the rear cover.
- 5 Move the right cover, being careful to clear the parallel port on the back of the unit.
- 6 Carefully disconnect the ribbon cable from the connector on the PC board and the other two cables that go to the cover.



## To remove the SIMMs

- 1 Facing the top of the SIMMs, push the side clips gently to the outside (away from the SIMM).
- 2 Push over and pull out, being careful not to damage the fingers on the top.

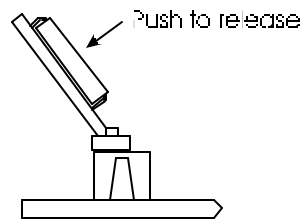
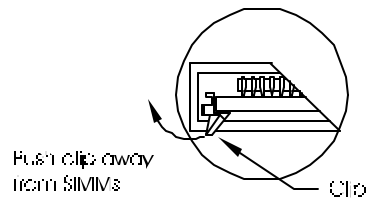
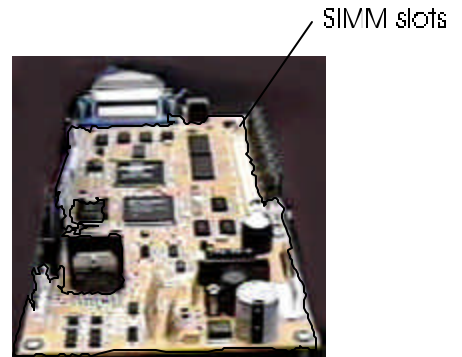

## To install the new SIMM

- 1 Insert at a 45 degree angle and slowly push the SIMM to a 90° angle until the two side clips snap into place. Make sure the SIMM is fully seated.

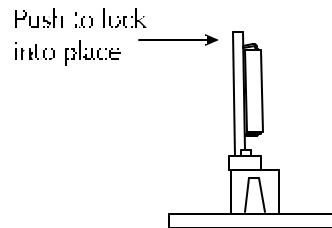
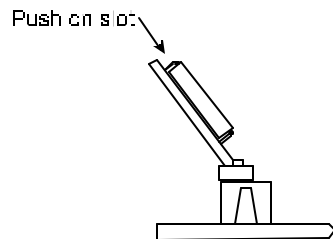

- 2 Carefully reconnect the ribbon cable harness to the connector on the PC board. Reattach the other connectors removed earlier.
- 3 Reinstall the right cover and top cover.



This section contains an overview of the printer's menu tree. Text items in *italics* indicate that selecting the option gives access to a menu with further options. Items in **bold** are the default option.

## Main menu at a glance

<b>Main Menu</b>	Load Media
	Cut
	Pause
	Reset
	<i>Feed Media Menu</i>
	Forward
	<i>Media Counter</i>
	<i>Display Counter</i>
	Backward
	Exit
	<i>Setup Menu</i>
	<i>Print Mode Menu</i>
	<i>Paper Option Menu</i>
	<i>HP-GL/2 Menu</i>
	<i>User Setup Menu</i>
	<i>Ink Option Menu</i>
	<i>Serial Comm Menu</i>
	Exit
	<i>Utility Menu</i>
	<i>Prime Menu</i>
	Access Cartridge
	<i>Color Calib Menu</i>
	<i>Calibration Menu</i>
	Display Settings
	Print Settings
	<i>Service Menu</i>
	Exit
	Exit

## Main menu

Load Media	moves media into or away from the platen.
Cut	cuts media.
Pause	provides access to further options for canceling print jobs, reinitializing the printer, or examining the job.
Reset	clears the print buffer. When cancelling a print, first remove it from the computer's print queue, then press the Reset button on the printer.
Feed Media Menu	provides access to further options for moving the media forward or backward and entering/displaying media length values.
Setup Menu	provides access to further submenus for setting printing options.
Utility Menu	provides access to further submenus for calibration and other functions.

## Feed media menu

Forward	advances media toward the front of the printer.
Media Counter	provides access to additional options where the length of a roll of media (0 to 500') can be entered and the media counter reset.
Display Counter	displays a screen where the current value of the media length can be viewed and printed on the media.
Backward	moves media toward the back of the printer.
Exit	returns to Main menu.

---

## Setup menu at a glance (Bold indicates the default)

<b>Setup</b>	Print Mode Menu	
	<i>Color Mode</i>	<b>Color</b> , mono, gray
	<i>Quality Mode</i>	draft, <b>photo</b> , enhanced, best
	Exit	
	Paper Option Menu	
	<i>Auto-Load Delay</i>	1-12, <b>6</b>
	<i>Save Media</i>	<b>On/Off</b>
	<i>Auto-Wipe</i>	<b>On/Off</b>
	Exit	
	HPGL/2 Menu	
	Palette Select	<b>HP-GL/2</b> , AutoCAD
	Control	<b>Software</b> , Printer
	Rotation	90, 180, 270, <b>Auto</b>
	<i>Nesting Menu</i>	
	Reprints	0...99 ( <b>0</b> )
	Ink Limit	<b>On/Off</b>
	Exit	
	User Setup Menu	
	<i>Select User</i>	1-8, <b>1</b>
	<i>Save User</i>	1-8, <b>1</b>
	<i>Units Select</i>	<b>English</b> , Metric
	<i>Language</i>	<b>English</b> , German, French, Italian, Spanish, Portuguese, Japanese, simplified and traditional Chinese, Korean
	Init Settings	
	Print Settings	
	<i>LCD Contrast</i>	1-16, <b>9</b> (16 is less contrast)
	Exit	
	Ink Option Menu	
	<i>Ink Reduction</i>	<b>0</b> , 12.5, 25, 37.5, 50
	<i>Ink Preheat Menu</i>	-7 (off) to 7 (max) for each cartridge ( <b>0</b> )
	EOP_Dry	<b>On</b> , Off
	Exit	

## Utility menu at a glance (Bold indicates the default)

### *Utility*

#### *Prime Menu*

- Prime All
- Clean
- Prime Single
- Start Routine

#### Access Cartridge

#### *Color Calib Menu*

- (color) vertical
- (color) horizontal
- Calib Print Test

#### *Calibration Menu*

- Use Calib XY* **On/Off**
- Paper Axis Test

#### *Color Db Menu*

#### *Open Jet Menu*

- Paper Axis* 32.00 - 34.00 (**33.00 default**)

#### Display settings

#### Print settings

#### *Service menu*

- Calibration menu
- Diagnostics menu
- About
- Cartridge Info
- Test Print

---

## Setup menu

Print Mode Menu	provides access to options for color, quality, dots per inch, and EOP dry.
Paper Option Menu	provides access to options for loading paper.
HP-GL/2 Menu	provides access to options for setting HP-GL/2 features.
User Setup Menu	provides access to options for defining and saving user settings.
Ink Option Menu	provides access to options for setting ink reduction and dry time.
Serial Comm Menu	provides access to options for setting communications parameters.
Exit	returns to the main menu.

## Print Mode

Color mode	provides access to a further menu to select <b>color (default)</b> , monochrome, or grayscale printing.
Quality mode	provides access to a further menu to select the print mode.
Exit	returns to the Setup menu.

## Paper Option Menu

Auto-Load Delay	provides access to a further menu to change the delay between when the media is positioned for loading and when loading occurs. This allows users to adjust the media if necessary. Select 1-12 seconds. <b>Default = 6.</b>
Save Media	provides access to a further menu to turn Save media <b>On (default)</b> or Off. When set to On, printing will stop at the end of the image rather than scrolling out the full paper size.
Auto-Wipe	provides access to a further menu to turn the Auto-wipe function On or <b>Off (default)</b> . When on, the cartridges are wiped during printing.
Exit	returns to the Setup menu.

## HP-GL/2 Menu

Palette Select	provides access to a further menu to select an AutoCAD color palette or a generic HP-GL/2 palette.
Control	determines whether certain printing parameters are set in the software application or overridden by the printer's front panel display.
Rotation	provides access to a further menu to enable rotation and set the rotation angle.
Nesting Menu	provides access to a further menu that controls nesting.
Reprints	controls the number of copies that are printed.
Ink Limit	limits the amount of ink that is used in polygon fills and wide vectors.
Exit	returns to the Setup menu.

## User Setup Menu

Select user	provides access to a further menu to select a previously saved user configuration. <b>Default = User 1.</b>
Save user	provides access to a further menu to save the current printer configuration to the selected user number. <b>Default = User 1.</b>
Units select	provides access to a further menu to choose the calibration units: <b>English (default)</b> or Metric.
Language	provides access to a further menu to select the language used for the display. Choose from <b>English (default)</b> , German, French, Italian, Spanish, Portuguese, Japanese, simplified and traditional Chinese, Korean.
Init settings	returns the printer to its default settings. All previously saved options are erased.
Print settings	prints the current printer settings.
LCD contrast	lets you select the contrast level of the display. Range is 1-16, <b>9 (default)</b> (16 is less contrast)
Exit	returns to the Setup menu.

---

---

## Ink Option Menu

Ink reduction	(applies to HPGL/2 only) provides access to a further menu in which to set the percentage by which to decrease the amount of ink emitted to help prevent bleeding or pooling of ink. Options are <b>0</b> , 12.5, 25, 37.5, and 50.
Ink preheat	provides access to a further menu in which you can select the cartridge for which you want to set the preheat value. Then you can set the ink preheat value for each cartridge. Options are -7 (off) to 7 (max) ( <b>default = 0</b> ).
EOP_Dry	EOP (End of page drying) ON enables the printer at the completion of the print job to automatically advance the media at the printing speed 12 inches to fully pass the IR heater. The media is then fed back into the printer at 25% of the normal reserve speed to avoid cockling on the retract move. End of Page dry OFF does not perform this at job completion and should be used when multiple copies are being printed.
Exit	returns to the Setup menu.

## Serial Comm Menu (Bold indicates the default)

For use by technical support only.

Baud rate	provides access to a further menu to select the baud rate: <b>9600 (default)</b> , 19200, 38400.
Data bits	7, 8
Parity bits	provides access to a further menu to select parity: <b>None (default)</b> , Even, Odd.
Exit	returns to the Setup menu.

## Utility menu

Prime Menu	provides access to further selections for prime single, prime all, start routine, and clean.
Access Cartridge	moves the ink carriage away from the service station for installing and replacing cartridges and the media cutter.
Color Calib Menu	provides access to further menus for printing the color calibration test pattern and for entering values determined by examining the test patterns.
Calibration Menu	provides access to a further menu for calibration options and diagnostics.
Display Settings	displays information such as media and page width and height, on time, and cumulative plot time.
Print Settings	prints information such as media size, firmware revision, RAM size, and plot hours.
Service Menu	provides access to the Service menu (technical support only)
Exit	returns to the Main menu.

---



---

## Prime menu

Prime All	Prints the prime pattern for each cartridge.
Prime Single	Provides access to a further menu in which you can choose to prime an individual cartridge.
Start Routine	Prints a recovery pattern/jet status plot.
Clean (Color)	Causes the selected cartridge to clear its jets by expelling a small amount of ink into the service station.
Clean All	Clears the jets for all the cartridges. Select this function whenever the printer has been idle for four hours or more.

## Color Calibration Menu

(Color) Vertical	lets you enter the number which corresponds to the best vertical alignment in the test pattern for the C, M, and Y cartridges.
(Color) Horizontal	lets you enter the number which corresponds to the best horizontal alignment in the test pattern for C, M, and Y cartridges.
Calib Print Test	prints the current heads, current horizontal head to head, and other calibration patterns described in the Quick Start Guide.

## Calibration Menu (Bold indicates the default)

Use Calib XY	provides access to a further menu in which you can set this function <b>On (default)</b> or Off.
Paper Axis Test	prints the paper axis test pattern.
Color Db Menu	provides access to a further set of menus in which you can print the color deadband test pattern and set deadband velocity compensation for each cartridge.
Open Jet Menu	provides access to a further set of menus in which you can print the jet status pattern and set the compensation for jets in each cartridge.
Paper Axis	provides access to a further menu in which to enter values determined by examining the paper axis test pattern.

## Service Menu (Bold indicates the default)

Calibration Menu	provides access to calibration options.
Diagnostics Menu	provides access to a further set of menus for performing diagnostics (tech support only) and for printing the color test.
About	provides information about the printer's firmware version, BROM, RAM, and printer size.
Cartridge Info	provides information about the type and color of ink in each cartridge stall, and the extent to which the cartridge is used. Cartridge usage is displayed in milliliters. The display changes in 2ml increments. 300ml indicates that the cartridge should be replaced. When 700ml is displayed, the cartridge will stop functioning.
Test Print	automatically prints a test file stored in ROM on the printer. Use only under direction of technical support.
Exit	returns to the Main menu.

# Technical information

# C

## **MEDIA TYPES:**

Untreated calendared vinyl, cast vinyl,  
banner vinyl

## **MEDIA ROLL PARAMETERS:**

Inner roll core: 2" +/- 1/16", and 3" +/- 1/16"  
with adapter  
Max. outside roll diameter: 6"  
Max. roll width: 36"  
Max. media weight: 60 lbs.

## **RESOLUTION:**

600 x 600 dpi

## **FEATURES:**

Power feed and takeup  
8 user-savable settings  
Power PC 33 MHZ processor  
Ink cartridges (4)  
500 ml ink reservoirs (4)  
Two sets of ink lines (8)  
Ink priming system

## **LINE LENGTH ACCURACY:**

+/- 0.2% in paper and carriage axis.  
  
Image frame length (x-axis) variation  
+/- 0.2% and with (y-axis) variation +/-0.06%  
+/-0.024" (.6mm).

## **BUFFER:**

Two 72-pin, 32-bit wide DRAM sockets.  
32 MB standard. User upgradeable to 128  
MB, 60 ns or faster, ENCAD approved.

## **INTERFACES:**

Bidirectional Parallel (IEEE 1284)  
10/100BaseT (optional)

## **POWER:**

200 - 240 VAC, 50 - 60 Hz, 7 amps

Consumption:

20 W Idle  
1000 W Typical  
1500 W Maximum

## **OPERATING ENVIRONMENT:**

59° - 85°F (15° - 30°C)  
20 - 70% RH, Non-condensing

## **STORAGE ENVIRONMENT:**

40° - 95°F (4° - 35°C)  
5-80% RH, Non-condensing

## **CERTIFICATIONS:**

Safety

UL 1950, 3<sup>rd</sup> Edition  
CSA 22.2 – 950  
EN 60 950  
NOM-019-SCFI-1993  
IEC 950, 2<sup>nd</sup> Edit.  
AS/NZS 3260

EMI

FCC Part 15 (Class A)  
CSA C108.8  
EN 55 022 Class A  
CE Mark  
CISPR 22- Class A  
AS/NZS 3548

**Made in the U.S.A.**

---

**DIMENSIONS:**

<b>Height (with stand) (platen above floor)</b>	44" (1120 mm)
<b>Width</b>	87" (2209.8 mm)
<b>Depth</b>	28" (710 mm)
<b>Weight</b> printer and stand	140 lbs. (62.2 kg)
<b>Print width</b>	24" min. to 36" max. printable

# Error messages

## D

A yellow LED on the control panel lights to indicate error conditions.

When the yellow LED lights, check the display for messages which will help you determine the status of the printer and possible corrective action to take.

### Cartridge errors

The printer automatically performs tests on the cartridges and uses the information to improve image quality, monitor cartridge life, and update the user with system status. Some tests are performed between prints and require no user input, while others require user input.

The following table shows cartridge-related error messages.

Error Message	Corrective Action
Unrecognized cartridge	Be sure the cartridge is the appropriate ENCAD cartridge for your printer model. Your printer will not work with cartridges from other models. Remember, the printer is reading the value programmed into the chip on the cartridge, it is not actually detecting the cartridge type. Replace the cartridge if necessary.
Cartridge end of life attained.	Replace cartridge. You can check cartridge status by choosing Disp Cart Info from the Service menu. End of cartridge life is indicated as 700ml.
Unrecognized ink type.	Be sure the cartridge is the appropriate ENCAD cartridge for your printer model. Your printer will not work with cartridges from other models. Ink type information is stored on the cartridge chip. If you are using a new type of ink which has been introduced since you purchased your printer, you will need to upgrade the printer's firmware to accommodate the new ink type. Check ENCAD's web site at <a href="http://www.encad.com">www.encad.com</a> for instructions.

When the cartridge error is displayed, choose Service Menu/Cartridge Info to get information about the cartridge. Press Utility Menu/Access Cartridge to move the cartridges out of the service station. After the cartridge has been replaced, cleaned, etc., press Access Cartridge again to return the cartridges to the service station.

---

## Memory Errors

If the "Insufficient raster memory" message displays, press the Reset button on the Main Menu to clear the message and abort the print job.

This appendix contains valuable information to help you solve the most common printer problems. The problems addressed are divided into these types:

- Printer health
- Print quality
- Data transfer
- Application software

## Troubleshooting quick list

Many common problems can be solved by checking for just two items:

- Is the printer connected to a good power source?
- Does the printer driver software match the emulation selected on the printer?

## Isolating problems

You can quickly isolate problems to either the printer, computer/printer interface, or application software using the following procedure:

1. Turn the printer OFF, then ON.
2. Load media, then run a prime to assure that all jets fire.
3. Perform a color calibration.

If your printer fails during any of the above steps, call your ENCAD distributor/dealer or call ENCAD Technical Support. Otherwise, continue with the steps that follow.

4. Send a sample print directly to the printer through the parallel port. For example, on Windows 95/98, type: `copy /b <filename>.rtl lpt1`. On Windows NT type: `print /d:lpt1 <filename>`.
5. If your computer is running on a network, login and copy the sample file to the printer over the network.
6. If steps 4 or 5 fail, repeat them using another computer.  
If any of these steps fail, your printer may not be correctly connected to your computer and/or network. Contact your network administrator or your ENCAD dealer. Otherwise, continue with the steps that follow.
7. Print directly to the printer from several software applications.

8. If you are networked, login and try printing from several software applications.
9. If steps 7 or 8 fail, repeat them using another computer or remove from the network and test standalone.

If one application fails, but others print successfully, that can indicate a problem with a specific software package. Call technical support of the failed product. If all the applications fail, determine what they have in common; for example, a RIP box or Windows driver. Call technical support of the particular vendor.

## Printer health

### **"Smoke" is coming from the media.**

This is actually water vapor coming off the media as it cures. This is normal.

### **Printer will not turn on**

Make sure the power cord is securely attached to the printer and plugged into an operating outlet.

Make sure the power switch is turned on.

Be sure that the grill in front of the IR bulb is securely engaged in the interlocking switch clip.

### **Printer intermittently reboots**

Clean and reseal memory SIMMs.

Replace memory SIMMs. (See Appendix A.)

Check that power is coming to the printer.

### **Display does not come on**

Check that the power cord is plugged in and the printer switch is turned on.

### **Printing doesn't start immediately when a file is sent**

If you are using a Windows application, be sure the Print Manager is OFF. Turn off the Print Manager with the ENCAD Windows driver.



---

### File will not print

If you are using a parallel cable, be sure it meets the specifications of IEEE 1284.

Check your electrical connections.

From your software application, print to a file and send the file to the printer in DOS using the DOS Copy command. At the DOS prompt, type **COPY /b filename portname** (LPT or COM port). Alternately, use the GO.EXE program which can be downloaded from ENCAD's website (<http://www.encad.com>). To print the file, type **GO filename**.

In Windows 95/98/NT4.0/2000/ME, you can use the EFPU, available on the System CD.

### Slow printing under Windows

Windows applications naturally print slower than DOS applications. Be sure the Windows Print Manager is turned OFF.

### Cutter doesn't work or tears the media

Make sure the cutter is properly installed. (See Quick Start Guide.)

**TURN POWER OFF** and clean the inside of the black belt using alcohol and a lint-free cloth. Push the carriage back and forth to access all areas of the belt. Manually push the carriage all the way to the left to force the cutter to drop. Turn power on.

If the cutter is worn, replace it.

### Carriage jams

Check for media jams or blockage.

Be sure the service station is lowering. If it does not lower, push it left and down, or the cutter will not disengage.

### Carriage axis failure

An obstruction in the path of the carriage assembly is hindering carriage movement. The obstruction may or may not be visible. Other common causes include dirty encoder strip, media interference, worn carriage bushings, cutter malfunction, and loose trailing cable connections.

After checking the following items, reboot the printer to ensure proper operation.

**Note:** If the error recurs, observe whether the carriage is in the same or different location.

If the carriage is in the same spot, check the encoder strip for visible damage (clear plastic strip under the trailing cable tray and above the belt) Refer to the figure which follows.

**Printer front view**

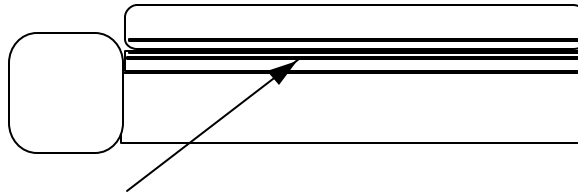

**Encoder strip under second trailing cable cover level, (clear plastic strip directly behind the shaft)**

**MAKE SURE POWER IS OFF BEFORE PERFORMING THIS STEP.** Verify that carriage movement is free and smooth by turning the power off and moving the carriage from one end of the shaft to the other (make sure there is no binding and that nothing is blocking the carriage movement ).

Clean the top and bottom of the encoder strip using a cotton swab and distilled water (let it dry completely, approximately 30 minutes, before trying to operate the printer).

Remove the cutter from the left side of the carriage and check it for visible damage. Make sure cutter version 3 (or newer) is installed (see the figure which follows).

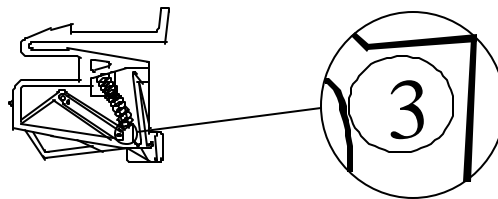

Check the shaft for visible damage (carriage moves back and forth on it during operation).

Clean the shaft with a lint free cloth and isopropyl alcohol (let it dry completely before trying to operate the printer).

Check the belt for visible damage such as fraying and pieces coming off it.

Check the trailing cable (cable that moves during printer operation) for visible damage.

---

---

Check whether the idler assembly (located at the left end of the belt) moves freely.  
Check whether it is cracked or broken.

### **Ink cartridges do not fire properly**

Be sure that cartridges and the service station are cleaned daily to maintain good print quality. (See the Maintenance Guide.)

Cartridges may wear out after extended use. Try replacing the cartridge.

Store cartridges in a sealed container at room temperature when not in use for extended periods of time.

Make sure the protective tape is removed from the cartridges.

Remove the cartridge and reinstall it, or clean the electrical contact on the cartridge and carrier. Be sure it is clean and dry. Be sure the cartridge is seated properly.

### **Various jets are clogged or stop firing**

Remove, clean, and reinstall cartridge. Use alcohol to clean the jet area if ink has dried on it.

Clean service station; clean cartridge again.

Clean cartridge electrical contacts using a cotton swab moistened with water. Dry contact. Do not use acetone or any other harsh cleaner as this may cause damage to the flex cable.

Jet may have failed. Bypass the jet using the Open Jet menu available from Utility Menu/Calibration Menu. If that doesn't help, replace cartridge.

Check to see whether spray from printing has contaminated the flex contact. Remove the cartridge and wipe the carriage flex and cartridge flex with a cotton swab moistened with water.

### **Ink spills on the flex cable**

Flex cable refers to the copper contacts on the carriage where the cartridge seats. Clean the flex cable gently with a cotton swab moistened with water. Do not use acetone or any other harsh cleaner as this may cause damage to the flex cable.

### **Printer settings are lost when printer is turned off or rebooted**

Be sure to save your printer settings to a User number. (See "Saving User Settings" in Chapter 2.) When you are ready to print, select the User number that you saved.

---

### **What if I need a firmware upgrade?**

You can download firmware upgrades from ENCAD's Internet web page ([www.encad.com](http://www.encad.com)).

#### **Firmware Download Procedure (Upgrade/Printer Refresh)**

You can use the ENCAD File Print Utility (EFPU) to download new firmware to your printer. The EFPU can be found on the System CD.

For Windows:

1. Using the EFPU, send the XXXX.ROM file to the printer. Approximately 20 - 40 seconds later, the unit will reboot, indicating the download was successful. After a one second delay, the printer will automatically reboot. The printer should come up normally. Verify the new firmware revision by sequencing through **Utility Menu/Service Menu/About**.
2. If there is no beep, reboot printer and reseal parallel port connection. Resend the .ROM file to the printer.

### **Print Quality**

Many of the print quality concerns can be resolved by priming, cleaning, and calibrating the cartridges. When this is the case, "clean, calibrate, or replace" is indicated with other solutions. Refer to the following chapters for details:

Clean - see Maintenance Guide

Calibrate - see Quick Start manual.

Replace - see Quick Start manual.

### **No print appears**

Check that tape has been removed from the printhead of the cartridge.

Make sure that the septum valve in the carriage and the needle two-piece septum, and the tubing part of the needle are tight and don't leak. Because this printer uses lots of heat, with time, the connections in the needle may become loose.

Be sure that ink levels are correct. Less than 50 ml in the reservoir can cause the lines to lose prime. Refill the reservoirs and reprime if necessary.

### **White lines or large gaps on print or portions of characters missing**

Clean, calibrate, or replace cartridges.

Make sure the media feeds freely.

---

**Overall print quality is poor**

Clean, calibrate, or replace cartridges.

Make sure the printer is positioned on level ground.

Use a higher quality print mode.

Be sure the media tension bar is inserted on the media as shown in the Quick Start Guide.

If you are using banner vinyl, be sure to insert the spacer bar into the media guides and run the media over the spacer bar.

Be sure that the platen temperature and IR lamp settings are correct for the media you are using.

Be sure you are using genuine ENCAD AV inks.

Blot the nozzle plate and nozzles with a wet lint-free cloth after every 50 ml of printing. This will help assure good quality printing and lengthen the cartridge life. Dry blot with a lint-free cloth and make sure ink comes out. Run the prime pattern.

**Streak marks**

Clean the service station daily, or more often, depending on the number of prints you are running. (See the Maintenance Guide.)

Clean, calibrate, or replace cartridges.

**Ink is not cured properly**

If the IR bulb has more than 1000 hours of printing, it may need to be replaced. (See the Quick Start Guide.)

**Colors print as monochrome**

Be sure the print mode mode is set correctly. To change a specific drawing from monochrome to color or vice versa, you must switch the print mode setting and re-transmit the file.

**Ink smears after removing the print**

Be sure that the platen heat and cure temperature are set correctly. It may be necessary to adjust the temperature depending on the ambient temperature in the room where the printer is used. Refer to the Quick Start Guide for details.

---

### **Smudged or dark characters**

Make sure the media is straight and unwrinkled when loading it into the printer.

Clean, calibrate, or replace cartridges.

Try a different print mode.

### **Improperly formed or misaligned characters**

Calibrate cartridges.

### **Color problems or shadowing**

Calibrate cartridges.

### **Excessive graininess**

Perform color deadband compensation. Refer to the Quick Start manual.

### **Colors are not correct or sections of print missing**

Clean, calibrate, or replace cartridges.

Check ENCAD's WEB site or bulletin board and download the latest Windows drivers. These drivers have calibrated color tables which act as a filter to your file and make the colors come out closer to what is on your computer screen.

If you are using a third party RIP, contact the RIP vendor to determine whether they have updated their color tables to work with ENCAD inks.

### **Image is the wrong size**

Be sure that your image file is set to 600 dpi.

### **Print contains only partial image**

Check that your image is not larger than the printable area of the media (34.8").

### **Jagged vertical lines**

Clean, calibrate, or replace cartridges.

If these suggestions fail, call Technical Support for instructions on cleaning the encoder strip and performing deadband calibration.

---

### **Spotchy area fill**

Try using **Best** mode. If the problem persists, clean, calibrate, or replace cartridges. Adjust cartridge preheat as described in Chapter 2.

### **Excessive banding in area fills**

Consistent banding is generally a hardware problem; inconsistent banding is generally a software problem.

Change the **Print Mode** option to **Best or Enhanced**. (See "Print Modes" in Chapter 2.)

Clean, calibrate, or replace cartridges.

Adjust cartridge preheat as described in Chapter 2.

### **Portions of lines are missing**

Clean, calibrate, or replace cartridges.

Clean service station; clean cartridge again; repeat prime.

Clean carriage flex cable and cartridge electrical contacts; repeat prime. Do not use alcohol, acetone, or other cleansers. Use a cotton swab moistened in distilled water.

Use tap water if distilled water is not available.

### **Poor vertical or horizontal line quality**

Perform color calibration. (See Quick Start Guide.)

## **Data Transfer**

### **Printer doesn't generate a print**

Be sure your printer is connected to the port to which you are sending the file.

If you are printing over a network, you will need to determine whether the problem is in the network. Try connecting the printer directly to your computer and send the file again.

### **Parallel printing doesn't work**

Some UNIX workstations have difficulty communicating with the printer using a parallel connection. Try connecting the printer to the network using a network interface box.

To ensure the highest quality and reliability of the data that is sent to the printers, the IEEE standard 1284 parallel cable is required to be used when utilizing the parallel port on the printers.

**Note:** Be sure that your parallel cable does not exceed the maximum of 10 ft.

This standard uses shielded twisted pair technology that reduces noise and increases performance at higher transfer speeds.

This cable is recommended on all printers built by ENCAD in 1997 and later.

To order from ENCAD, use part number 208559.

Try using another parallel cable. Be sure that it is securely connected.

### **No output when printing from Unix**

If you encounter “no output” problems when printing from Unix, try the following:

1. Check the printer hardware.
  - Check that the printer is plugged in and turned on.
  - ? Check that the cable is connected to the port on the printer and the port on the workstation or server.
    - Check that the cable is the correct cable and is not defective.
    - Check that hardware switches for the port are correctly set.
    - Run the demo print available from Utility Menu/Service Menu/Test Print to assure that the printer is functioning.
2. Verify network connections.
  - On a print client or server, type *ping system-name* and press Return. This command checks that the network link between the print server and print client is set up correctly.

If the message says the system is alive, the network is functioning. The message also tells you that either a naming service or the local /etc/hosts file has translated the host (system) name entered into an IP address. If it hasn't, you must enter the IP address.

- If you get a “not available” message, check the following:
  - How is NIS or NIS+ set up at the site?



- 
- Do you need to take additional steps to allow the print servers and print clients to communicate with each other?
  - If your site is not running NIS or NIS+, have you entered the IP address for the print server in each client's /etc/hosts file and entered all print client IP addresses in the /etc/hosts file of the print server?
  - Check that the port monitor is configured correctly on the print server.
  - Check that the network listen services are registered with the port monitor on the print server.
3. Check the LP print service.
- On both the print server and print client, make sure the LP print service is running.
  - On both the print server and client, make sure the printer is accepting requests.
  - On both the print server and print client, make sure the printer is enabled to print requests.
  - On the print server, make sure the printer is connected to the correct serial port.
  - On both the print server and print client, make sure the printer is configured properly.
  - On the print server, make sure the printer is not waiting because of a fault.
  - Make sure the printer is not set up as a login terminal.

## Application Software

### Isolating a problem to your software

Sometimes printing problems are application software-specific.

Try printing the test print available from the Service menu. If it prints correctly, the printer's health is probably good.

Try printing a simple file from your application or from another application. If this prints correctly, the problem may be with your software.

If you are using a Windows application and the file does not print from Windows, try printing a file from DOS. If this prints correctly, your problem may be with your Windows driver or Windows setup.

**Difficulty generating prints ranging from A to D size**

Many software applications limit the maximum print size to “C” or “D” size due to the way that they map their internal coordinate system to memory.

Some applications which limit maximum print size are listed below:

- Microsoft Word: 22 x 22”
- Lotus 123: 17 x 22”
- CorelDRAW: 30 x 30” (TIFF files are limited to 11 x 17”)
- Microsoft Project: 36 x 61”
- Micrographx Designer: 68” maximum
- Ashlar Vellum: 101” maximum

**Windows GDI Print Length Limitation**

The Windows operating system uses a Graphics Device Interface which limits printing to 16,000 pixels. The media length at 300 dots per inch is equal to 16,000 divided by 300.

What all this means is:

There is a limit of 53" for vector data in Windows 95. For raster images, the limit is 109". These limits are imposed by the Windows 95 Graphics Device Interface (GDI). The limitation of 53" is based upon a 16,000 pixel limit for a vector. The printer has a resolution of 300 Dots Per Inch (DPI). To find the largest size divide 16,000 by 300 to get the size in inches. (53.333"). The limitation of 109" is for the size of the digital word that is sent between the application and the driver. This word is 16-bits long. The maximum positive value that can be placed in a 16-bit word is 32,767. Therefore, by dividing 32,767 by 300 we get 109.223". Many Windows applications limit the maximum print size to "C" or "D" size due to the way that they map their internal coordinate system to memory.

Some applications which limit maximum print size are listed below:

Microsoft Word:	22" x 22"	Micrographx Designer:	68" maximum
Lotus 123:	17" x 22"	Ashlar Vellum:	101" maximum
Microsoft Project:	36" x 61"	Adobe PageMaker:	42" x 42"
QuarkXPress:	48" x 48"	CorelDRAW:	30" x 30"*

\*(TIFF files are limited to 11" x 17")

\*Note: This is a 30" x 30" page size, and is relevant to Corel 5.0 applications only. CorelDRAW 6 and later versions are now capable of supporting page sizes beyond 36 x 36 inches to a maximum of 150 feet x 150 feet. Due to a limitation in the HP DesignJet 650C Series printers driver, the maximum attainable page size is approximately 55 x 55

---

inches. Larger page sizes may be attainable if the resolution in the driver is lowered. This limitation also applies to the HP 750C printer, and 16 bit printer drivers under Win95. Programs that use their own internal drivers that bypass the Windows operating system are not real common but they do exist. Also, other driver programs or RIPs were created specifically to achieve special capabilities including: increased speed, scaling, color correction / calibration, extended print length, etc.

These programs don't use their own O/S (operating system). But, they create certain conditions that bypass those particular areas of the Windows O/S limitations. Some programs with internal drivers to print from include: AutoCAD, MicroStation, FlexiSign Pro, PosterShop, CactusJet, etc. External printer driver RIPs are made by Pisa, Fiery (EFI), ZenoGraphics, Intelligent Systems, Wasatch, etc.

It should also be noted that this limitation is only because of the GDI limitations. ENCAD printers do not have this limitation. Length limitations are a function of software or RIP parameters. Any conflicts that do not use the GDI interface should be directed to the software vendors.

## Calling for Help

If you have tried the suggestions in this manual and still need assistance, call the ENCAD dealer where you purchased your printer.

Before you call technical support for help, be sure that you have all of the following information available:

### **Printer Information**

- model
- firmware revision (letter)
- memory
- serial number

### **Computer Information**

- model
- operating system

## Customer Technical Support

To resolve printer problems, use the suggestions provided in this guide. If you continue to have problems, you can get help from any of the following:

### ENCAD Inc. Support

ENCAD Inc.  
6059 Cornerstone Ct. West  
San Diego, CA 92121-3734

Main Number	(858) 452-0882
Customer Support	(877) ENCADTS
Customer Support FAX	(858) 558-4672
Home Page	<a href="http://www.encad.com/">www.encad.com/</a>
Warranty Cartridge Exchange	(877) ENCADTS
Supplies Sales	(888) 747-9303
No. American Sales	(800) 45-ENCAD

### ENCAD Inc. - France

Customer Support	+33-1-58098100
Customer Support FAX	+33-1-58098101

### ENCAD Inc. - Germany

Customer Support	+49-89-6603-90342
Customer Support FAX	+49-89-6603-9043

### ENCAD Inc. -Asia

Customer Support	+852-2881-8969
Customer Support FAX	+852-2881-0912

\*Priority support is available for all customers - warranty and non-warranty. The cost of \$2.50 per minute is billed directly to your phone bill. Be sure to have your printer's serial number when calling.

\*\* available for all customers - warranty and non-warranty. For non-warranty customers, the cost is \$25.00 per call which can be billed to a credit card. Be sure to have your printer's serial number when calling.