

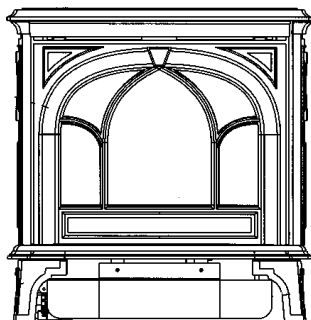

GF 200 DV Lillehammer Gas Heater



Installation
and
Operation
Instructions



WARNING:

IF THE INFORMATION IN THESE INSTRUCTIONS ARE NOT FOLLOWED EXACTLY, A FIRE OR EXPLOSION MAY RESULT CAUSING PROPERTY DAMAGE, PERSONAL INJURY OR LOSS OF LIFE.

FOR YOUR SAFETY:

DO NOT STORE OR USE GASOLINE OR OTHER FLAMMABLE VAPORS AND LIQUIDS IN THE VICINITY OF THIS OR ANY OTHER APPLIANCE.

INSTALLATION:

INSTALLATION AND SERVICE MUST BE PERFORMED BY A QUALIFIED INSTALLER, SERVICE AGENCY OR LICENSED GAS SUPPLIER.

WHAT TO DO IF YOU SMELL GAS:

- **DO NOT TRY TO LIGHT ANY APPLIANCE.**
- **DO NOT TOUCH ANY ELECTRICAL SWITCHES.**
- **DO NOT USE THE PHONE IN YOUR BUILDING. IMMEDIATELY CALL YOUR GAS SUPPLIER FROM A NEIGHBOR'S PHONE.**
- **FOLLOW YOUR GAS SUPPLIER'S INSTRUCTIONS.**
- **IF YOU CANNOT REACH YOUR GAS SUPPLIER, CALL THE FIRE DEPARTMENT.**

AVERTISSEMENT:

ASSUREZ-VOUS DE BIEN SUIVRE LES INSTRUCTIONS DANS CETTE NOTICE POUR REDUIRE AU MINIMUM LE RISQUE D'INCENDIE OU POUR EVITER TOUT DOMMAGE MATERIEL, TOUTE BLESSURE OU MORTALIT'E.

NE PAS ENTREPOSER NI UTILISER D'ESSENCE NI OU LIQUIDES INFLAMMABLES DANS LE VOISINAGE DE CET APPAREIL OU DE TOUT AUTRE APPAREIL.

L'INSTALLATION LE SERVICE DOIVENT ETRE EXECUTES PAR UN INSTALLATEUR QUALIFIE, AGENCE DE SERVICE OU LE FOURNISSEUR DE GAZ.

QUE FAIRE SI VOUS SENTEZ UNE ODEUR DE GAZ.

- **NE PAS TENTER D'ALLUMER L'APPAREIL**
- **NE TOUCHEZ A AUCUN INTERRUPTEUR.**
- **NE PAS VOUS SERVIR DES TELEPHONES SE TROUVANT DANS LE BATIMENT OU VOUS VOUS TROUVEZ.**
- **APPELEZ IMMEDIATEMENT VOTRE FOURNISSEUR DE GAZ CHEZ UN VOISIN. SUIVEZ LES INSTRUCTIONS DU FOURNISSEUR.**
- **SI VOUS NE POUVEZ REJOINDRE LE FOURNISSEUR DE GAZ, APPELEZ LE SERVICE DES INCENDIES.**

Welcome to Jøtul...

Congratulations on the purchase of your new Jøtul GF 200 DV Lillehammer - a direct vented gas heater especially designed and approved for installation into a variety of configurations where close clearance to combustibles is required.

We at Jøtul are glad you've made the decision to warm your hearth with a Jøtul product. Your new Lillehammer benefits from our experience as the world's largest manufacturer of solid fuel burning appliances for over 140 years. We've been making fine quality cast iron wood and coal stoves and fireplaces continuously since 1853.

In the Lillehammer, we've combined advanced gas technology with the warm, traditional elements of cast iron. With proper care and use, your Jøtul stove will provide you with many years of safe, dependable and satisfying service.

Please take a few minutes to familiarize yourself with this manual and the features of your Lillehammer gas stove. Locate the serial number stamped onto the Rating Plate which is attached to the bottom of the stove. Record this number in the Maintenance Record section of this manual for future reference.



Jøtul GF 200 Lillehammer Direct Vent Gas Heater

Manufactured and Distributed by:
Jøtul A.S.A.
Fredrikstad, Norway
Jøtul North America
Portland, Maine

Test Standards

This appliance complies with National Safety standards and is tested and listed by Intertek Testing Services of

Middleton, Wisconsin to ANSI Z21.88-1998 (NFPA 54) and CSA 2.33-M98 for Canada.

DO NOT ATTEMPT TO ALTER OR MODIFY THE CONSTRUCTION OF THE APPLIANCE OR ITS COMPONENTS. ANY MODIFICATION OR ALTERATION WILL VOID THE WARRANTY, CERTIFICATION AND LISTING OF THIS APPLIANCE.



Suggested Tools for Installation and Service

- External regulator (for Propane only)
- Piping which complies with local code
- Manual shutoff valve - **T-Handle in MA**
- Sediment trap - if required by code
- Tee joint
- Pipe wrench
- Pipe sealant
- 10mm open end wrench
- 1/2", 7/16" open end wrench
- Phillips head screwdriver
- Flat head screwdriver
- 1/4" nut driver
- Gloves
- Safety glasses
- Torx T20 screwdriver
- Leak test solution
- Reciprocating Saw
- Power Drill

Table of Contents

Specifications	3
General Information	5
Safety Information	6
Hearth Protection Requirements	6
Clearance Requirements	7
Mantel and Trim Clearances	7
Venting Requirements	8
Draft Restrictors	8
Vertical Vent Systems	9
Co-linear Hearthmount Systems	10
Vent Height Requirements	11
Horizontal Vent Options	12
Wall Shield Installation	13
Vent Termination Clearances	14
Mobile Home Installation	15
Fuel Conversion	16
Gas Connection	17
Gas Pressure	18
High Altitude Adjustment	19
Air Shutter Adjustment	20
Log Set Installation	20
Thermostat / Remote Control	21
Checking the System	21
Operation	22
Maintenance	23
Maintenance Record	24
Parts Illustration	25
Replacement Parts List	26
Lighting Instructions	Back Cover

**THIS PRODUCT MUST BE INSTALLED BY
A LICENSED MASTER PLUMBER OR GAS-
FITTER WHEN INSTALLED IN THE COM-
MONWEALTH OF MASSACHUSETTS.**

Jøtul GF 200 DV Lillehammer Specifications

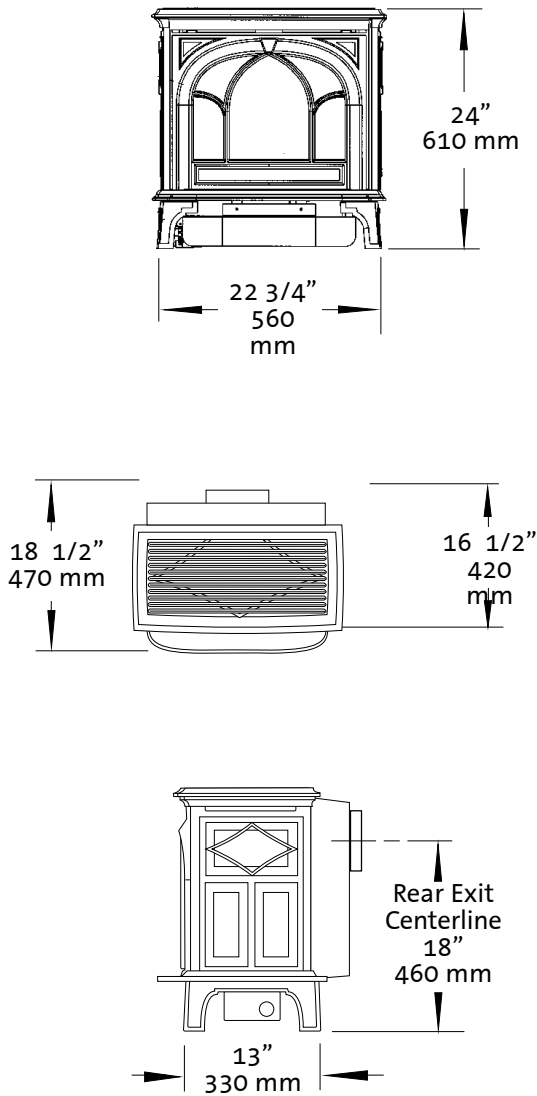

Figure 1. Dimensional Views - GF 200 DV Lillehammer

Input Rates

Natural Gas

18,000 BTU/hr. maximum input
13,500 BTU/hr. minimum input

Propane

18,000 BTU/hr. maximum input
13,500 BTU/hr. minimum input

Inlet Pressure:

	<u>MIN</u>	<u>MAX</u>
Natural Gas:	5.0 WC (1.24 kPa)	7.0 WC (1.74 kPa)
Propane:	11.0 WC (2.73 kPa)	13.5 WC (3.36 kPa)

Manifold Pressure:

	<u>MIN</u>	<u>MAX</u>
Natural Gas:	2.2 WC (.54 kPa)	3.5 WC (.87 kPa)
Propane:	6.5 WC (1.61 kPa)	10.0 WC (2.49 kPa)

Efficiency: 82%

Steady State (A.F.U.E.): 73%

Piezo Ignitor / Standing Pilot

The Jøtul GF 200 DV Lillehammer is a Direct Vent wall furnace designed as a sealed combustion, air circulating gas appliance for residential applications. This appliance is approved for installation using 6 5/8" X 4" vent pipe from the following manufacturers:
Simpson Dura-Vent GS
Security Vent, Ltd.
Amerivent Inc.

The Jøtul Lillehammer gas stove is designed to burn NATURAL GAS or PROPANE only. **It is shipped from the factory equipped to burn Natural Gas. If use with Propane is desired, the stove must first be converted for use with that gas. Use the LP Fuel Conversion Kit included with this stove See page 15.**

GF 200 DV Lillehammer Options

- Fuel Conversion Kit - NG..... 155349
- Fuel Conversion Kit - LP 155350
- High Altitude Conversion Kit - NG 154371
- High Altitude Conversion Kit - LP 154373
- Wall Thermostat 750003
- Remote Control 129706
- Mobile Home Floor Bracket Kit 154342

General Information

- **THIS HEATER MUST BE INSTALLED AND MAINTAINED BY A QUALIFIED SERVICE AGENCY.**
- **THIS APPLIANCE MUST NOT BE CONNECTED TO A CHIMNEY OR FLUE SERVING ANY OTHER APPLIANCE.**
- The installation and repair of this appliance must be done by a qualified service person. Failure to properly install and maintain this heater could result in an unsafe or hazardous installation, which may result in a fire, explosion, property damage, personal injury or loss of life.
- This appliance should be inspected before use and at least annually. More frequent cleaning may be required due to excessive lint from carpeting, bedding material, etc. It is imperative that control compartments, burners, and circulating air passageways of the appliance be kept clean.
- The installation must conform to local codes. Your local Jøtul dealer can assist you in determining what is required in your area for a safe and legal installation. Some areas require a permit to install a gas burning appliance. Always consult your local building inspector, or authority having jurisdiction, to determine what regulations apply in your area.
- **REMEMBER:** Your local officials have final authority in determining if a proposed installation is acceptable. Any requirement that is requested by the local authority having jurisdiction, that is not specifically addressed in THIS manual, defaults to local code. In the absence of local codes, the installation requirements must comply with the current National codes. In the U.S., these requirements are established in the National Fuel Code, ANSI Z223.1.(NFPA 54). In Canada, the codes have been established in CAN/CGA B149 Fuel Installation Code.
- Installer l'appareil selon les codes ou règlements locaux, ou, en l'absence de tels règlements, selon les Codes d'installation CAN/CGA-B149.
- **DO NOT OPERATE THIS STOVE IF ANY PART HAS BEEN UNDER WATER.** Call a qualified service technician to inspect the heater and to replace any part of the control system and any gas control which may have been under water.
- Ne pas se servir de cet appareil s'il a été plongé dans l'eau, complètement ou en partie. Appeler un technicien qualifié pour inspecter l'appareil et remplacer toute partie du système de contrôle et toute commande qui ont été plongés dans l'eau.

Glass Panel

DO NOT OPERATE THE LILLEHAMMER GAS STOVE WITH THE GLASS FRONT REMOVED, CRACKED OR BROKEN. REPLACEMENT OF THE GLASS SHOULD BE DONE BY A LICENSED OR QUALIFIED SERVICE PERSON. ONLY REMOVE GLASS FOR ROUTINE SERVICE. ALWAYS HANDLE GLASS CAREFULLY.

SEE THE MAINTENANCE CHAPTER FOR INSTRUCTIONS ON REPLACING THE GLASS PANEL.

Safety Information

The Jøtul GF 200 Lillehammer gas stove during normal operation, will reach high surface temperatures. Read and follow the safety guidelines below.

- Due to the high operating temperatures, this appliance should be located out of traffic and away from furniture and draperies.
- Children and adults should be alerted to the hazards of high surface temperatures and should stay away to avoid burns or clothing ignition.
- Young children should be supervised while they are in the same room as the Lillehammer gas stove.
- Clothing or other flammable materials should not be placed ON or NEAR the Lillehammer gas stove. Surveiller les enfants. Garder les vêtements, les meubles, l'essence ou autres liquides à vapeur inflammables loin de l'appareil.
- NEVER store or use gasoline or any other flammable vapors or liquids in the vicinity of the Lillehammer gas stove.
- Never burn any other materials in your Lillehammer gas stove, it is strictly designed for use with natural gas or propane fuel ONLY.
- Any safety screen, glass or guard removed for servicing the appliance must be replaced prior to operating the appliance.

Locating the Stove

In selecting the location, the aesthetic and functional use of the appliance are primary concerns. However, proper venting systems and access to the fuel supply are also important issues. Due to the high surface temperatures of the Lillehammer, one must also consider the proximity of traffic ways, furniture, draperies, etc.

This appliance may be located on or near conventional construction materials. HOWEVER, always maintain the proper clearances to combustibles, as this provides adequate ventilation air around the appliance.

The following clearances and hearth requirements are the minimum requirements when installing the Lillehammer gas stove near or on combustible surfaces. Always provide adequate access around the appliance for servicing and proper operation.

A combustible surface is anything that can burn (i.e. sheet rock, wall paper, wood, fabrics etc.). These surfaces are not limited to those that are visible and also include materials that are behind non-combustibles.

If you are not sure of the combustible nature of a material, consult your local fire officials. Remember, "Fire Resistant" materials are considered combustible: they are difficult to ignite, but will burn. Also, "fire-rated" sheet rock is considered combustible.

Hearth Requirements

The Jøtul GF 200 Lillehammer gas stove CANNOT be installed directly on carpeting, vinyl flooring, Pergo®, or linoleum. If it is desired to install this appliance on any combustible material OTHER THAN WOOD, a floor pad must be installed that is either metal, wood or a listed hearth pad. This floor protection must extend the full width and depth of the appliance. It is not necessary to remove the carpeting, vinyl or linoleum from underneath the floor protection.

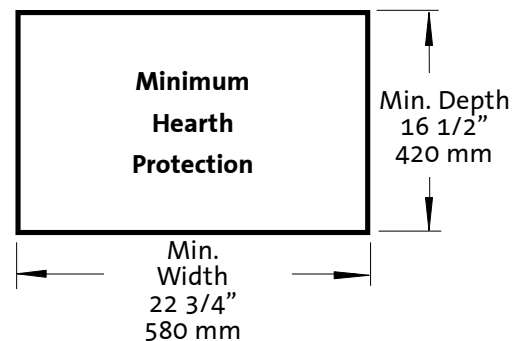

Figure 2. Lillehammer Hearth Protection

Clearance to Combustibles

Minimum Stove Clearance

Rear	0"	(0mm)
Ceiling	17"	(432mm)
Corner	2"	(51mm)
Right Side	2"	(51mm)
Left Side	*10"	(255mm)

* Necessary for complete access to pull out required Lighting Instructions Plate.

Minimum Vent Pipe Clearance

Horizontal runs:

Off the top of the pipe -	2"	(26mm)
Off the sides and bottom -	1"	(26mm)

Vertical runs:

All sides -	1"	(26mm)
-------------	----	--------

See Figures 4 and 5.

Mantel and Trim Clearances

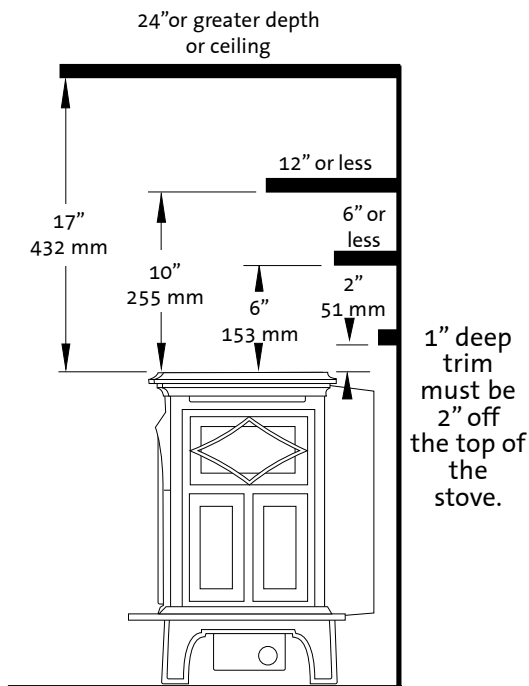
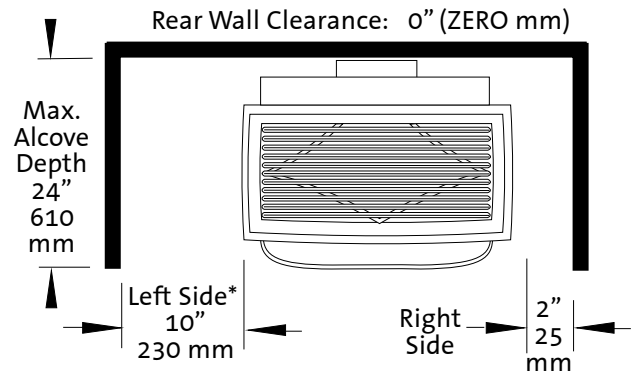

Figure 3. Mantel / Trim Clearances

Parallel Installation



* Allow 10" on left side of the appliance for complete access to the lighting instructions and control valve.

Figure 4. Clearances with stove parallel to the walls

Alcove Installation

Maximum Depth:	24"	(610mm)
Minimum Width:	35"	(890mm)
Minimum Ceiling Height:	42"	(1067mm)

Corner Installation

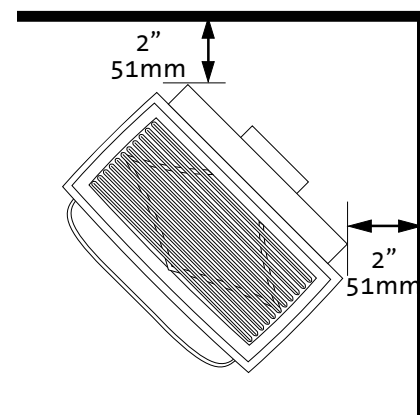

Figure 5. Clearance to rear corners.

Venting Requirements

There are three types of venting configurations approved for use with the Lillehammer gas stove:

- **Hearthmount Co-Linear** (Vertical Termination)
- **Vertical Venting** (Vertical Termination)
- **Horizontal Termination** (Horizontal Termination)

The Lillehammer is approved for use with the vent systems listed below. Use parts of one manufacturer only - DO NOT MIX VENT COMPONENTS FROM DIFFERENT MANUFACTURERS IN THE SAME SYSTEM.

- **Simpson Dura-Vent GS**
- **Amerivent Corporation**
- **Security Vent Ltd.**

Installation of any components not manufactured or approved by Jøtul or failure to meet all clearance requirements will void all warranties and could result in property damage, bodily injury, or serious fire.

The approved vent configurations described in this manual are derived from extensive testing under controlled laboratory conditions. Gas appliance performance can be negatively affected by variables present in the installation environment, i.e.: atmospheric pressure, strong prevailing winds, adjacent structures and trees, snow accumulation, etc. These conditions should be taken into consideration by the installer and stove owner when planning the vent system design.

IMPORTANT

- **JOINT SEALING REQUIREMENT:** APPLY A 1/8" BEAD OF HIGH-TEMPERATURE (750°F) SEALANT TO THE MALE SECTION OF THE INNER VENT PIPE. SEE FIG. 9. THE CEMENT SHOULD FORM A SEAL BETWEEN THE INNER AND OUTER PIPES.
- NEVER MODIFY ANY VENTING COMPONENT, OR USE ANY DAMAGED VENTING PRODUCT.
- THE GAS APPLIANCE AND VENT SYSTEM MUST BE VENTED DIRECTLY TO THE OUTSIDE OF THE BUILDING AND NEVER ATTACHED TO A CHIMNEY SERVING A SOLID FUEL OR GAS BURNING APPLIANCE. EACH DIRECT VENT GAS APPLIANCE MUST HAVE ITS OWN SEPARATE VENT SYSTEM. COMMON VENT SYSTEMS ARE PROHIBITED.
- IF VENTING SYSTEM IS DISASSEMBLED FOR ANY REASON, REINSTALL PER THE INSTRUCTIONS

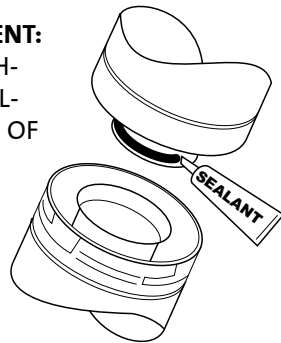

Vent Restriction

The GF 200 DV Lillehammer includes two draft restrictor plates found in the parts bag. These must be installed together within the stove in the following vent configurations:

- 1) ANY vertically vented installation
- 2) ANY horizontal vent utilizing a Snorkel Termination.

Additional restriction may be necessary, depending on the vent height.

The plates are used to compensate for draft characteristics that would otherwise interfere with proper burner performance such as low heat output, weak flame picture, or inefficient combustion. **Both restrictors must be installed. See Figs. 6 and 7.**

Install the Exhaust Restrictor Plate

1. Remove the Top Plate to access the Glass Panel.
2. Release the Glass Panel latches and lift the panel straight up off of the firebox.
2. Carefully remove the Log Set pieces from the firebox.
2. Use a 1/4" nut driver to remove the two lower sheet metal screws located inside the firebox below the exhaust outlet. Install the rectangular restrictor plate over the lower half of the outlet and secure it using the same screws.

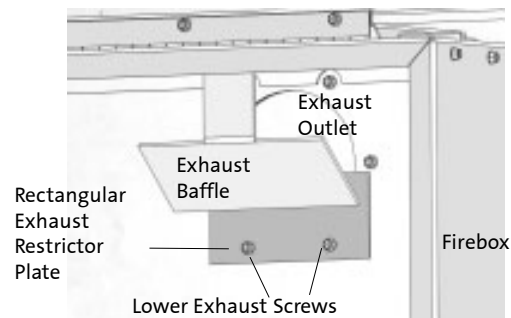

Figure 6. Install the Exhaust Restrictor Plate.

Install the Air Inlet Restrictor Plate

1. Using a 1/4" nut driver, remove the left hand sheet metal screw holding the Air Deflector to the rear wall of the firebox. See Fig. 7.
2. Slide the Air Inlet Restrictor down along the rear wall of the firebox behind the Air Deflector, so that the Restrictor plate completely covers the air intake inlet.
3. Secure both the Restrictor plate and the Deflector to the rear wall using the same screw.

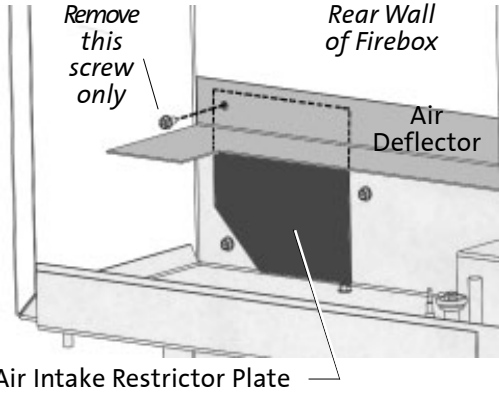

Figure 7. Install the Air Inlet Restrictor Plate.

Vertical Venting Requirements

These requirements apply to any installation that includes a vertical vent run.

The GF 200 DV Lillehammer can be vertically vented through a roof or ceiling following these guidelines:

- Steep roofs, nearby trees, and predominantly windy conditions can contribute to poor draft or down-draft occurrences. Increasing the height of the vent may alleviate these conditions.
- Use Simpson Dura-Vent Wall Straps (#988) to support an offset pipe run at three feet intervals to avoid excessive stress on the offsets.
- Whenever possible use 45° elbows instead of 90° elbows as they are less restrictive to exhaust gas and intake air flow.
- **GAS VENT RULE:** In no case shall any discharge opening on the cap be less than 2' (610mm) horizontally from the roof surface. See Figure 11.
- A firestop is required at every floor. The opening should be framed to 10" X 10" inside dimension. **Simpson Dura-Vent Ceiling Firestop #943 is required.**
- Any venting that is exposed above the first floor, regardless of attic space or living space, must be enclosed. Always maintain the required 1" clearance from all sides of the vertical vent system.
- **Install the Exhaust Gas Restrictor in all Vertically Terminated vent systems.** See the Adding Restriction section on page 8.
- A vertical run in any horizontally-terminated system must rise a minimum of 1 ft. See Fig. 12-5.

VERTICAL VENTING, OR ANY HORIZONTAL VENTING WITH VERTICAL RISE, MUST TERMINATE (END) WITHIN THE SHADED AREA.

- RESTRICTOR REQUIRED ON ALL VERTICAL VENTING.
- ALWAYS MAINTAIN THE PROPER CLEARANCES TO COMBUSTIBLES.

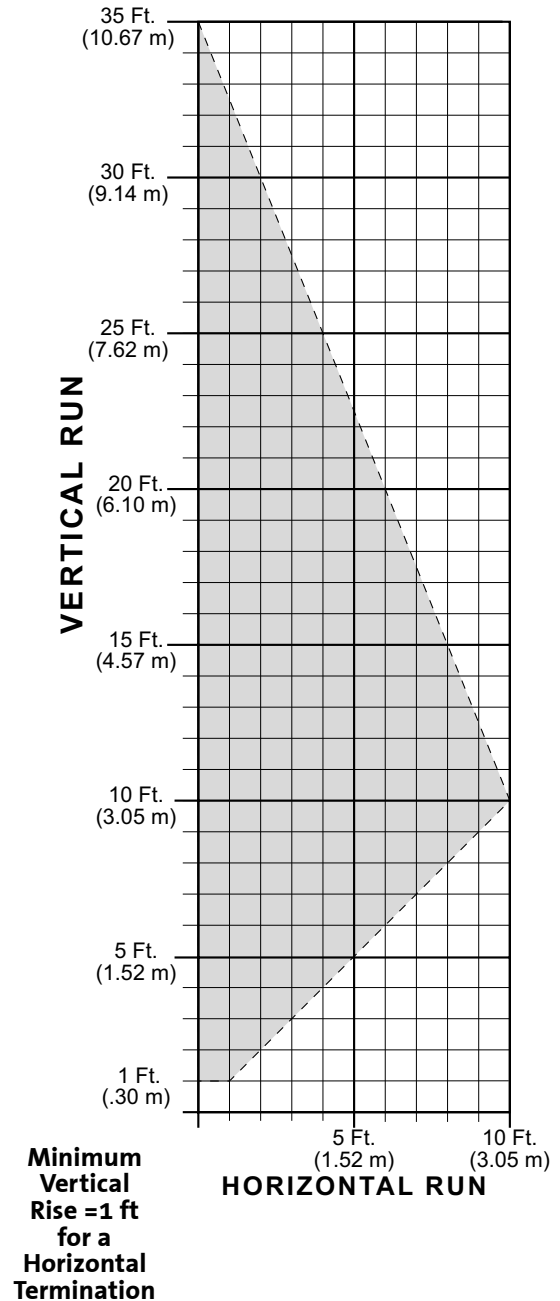

Table 1. Vertical vent run Termination Window.

Co-linear Hearthmount Installation

The Jøtul GF 200 DV Lillehammer may be vented through a masonry fireplace using Simpson Dura-Vent Chimney Liner Conversion Kit 923GK. When installed in the manner described below, this system can improve the performance of the appliance in cold climate situations, as well as simplify the vent installation.

These guidelines must be followed:

1. Prior to the installation, the chimney flue must be thoroughly cleaned and inspected by a qualified chimney service person.
2. In a masonry chimney, a fireclay liner or listed steel liner, must be present the entire length of the chimney.
3. No appliance can be installed into a chimney flue serving any other appliance of any kind.
4. The minimum length of the **AIR INTAKE FLEX** is **6 feet- measured off of the back of the appliance** and **IT MUST EXTEND PAST THE DAMPER AREA OF THE FIREPLACE.**
5. If the intake flex does not extend the full length of the chimney and connect to both the unit and the termination cap, A **METAL BLOCK OFF PLATE** MUST BE CONSTRUCTED AND INSTALLED ABOVE THE UNIT PRIOR TO THE END OF THE INTAKE FLEX AND MUST COMPLETELY SEAL THE CHIMNEY FLUE FROM THE ROOM.

Consult with the local code authority having jurisdiction before proceeding with this type of installation.

Refer to the vent manufacturer's instructions for specific installation requirements.

WARNING: FAILURE TO POSITION THE PARTS AND STOVE IN ACCORDANCE WITH THESE DIAGRAMS OR FAILURE TO USE ONLY PARTS SPECIFICALLY APPROVED FOR USE WITH THIS APPLIANCE MAY RESULT IN PROPERTY DAMAGE OR PERSONAL INJURY. BE SURE TO MAINTAIN THE PROPER CLEARANCES TO COMBUSTIBLES AS DEFINED IN THIS MANUAL AND INM THE INSTRUCTIONS PROVIDED WITH EACH VENT COMPONENT.

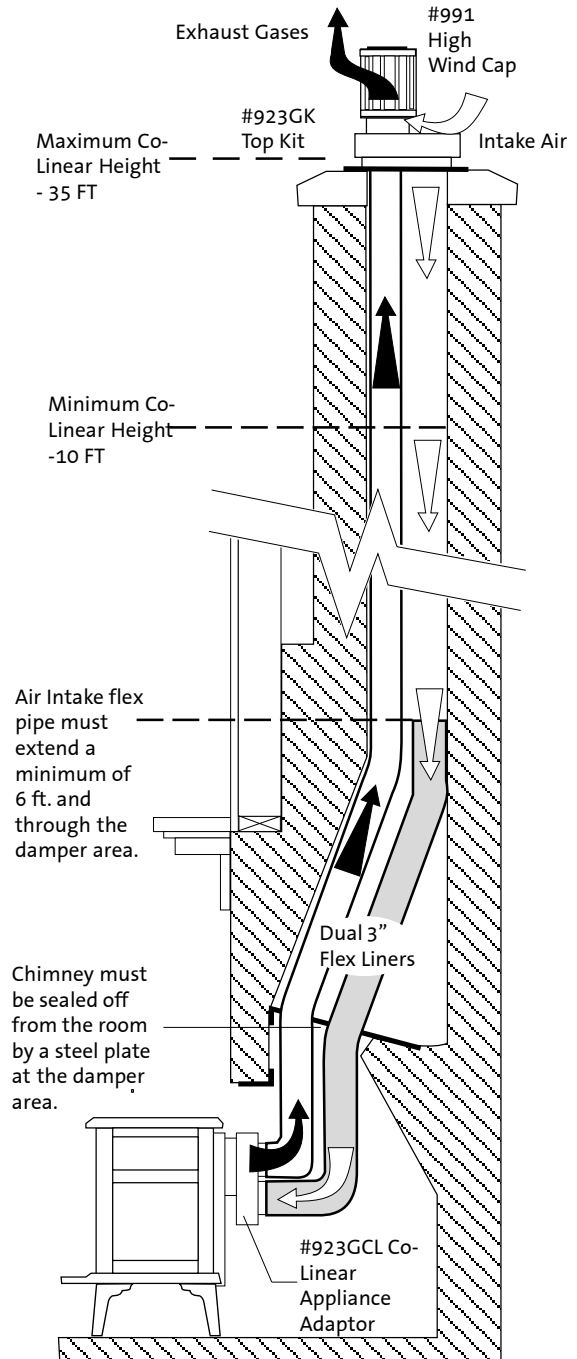

Figure 8. Co-Linear Vent System installed in a masonry fireplace.

IMPORTANT NOTICE

THE USE OF AN EXISTING CHIMNEY AS AN AIR INTAKE IS NOT COVERED UNDER THE ANSI Z21.88-1999-CSA 2.33-M99 TEST METHODS AND RESULTING ITS/WHI PRODUCT CERTIFICATION. THE CODE AUTHORITY HAVING JURISDICTION MUST BE CONSULTED PRIOR TO PROCEEDING WITH THIS INSTALLATION

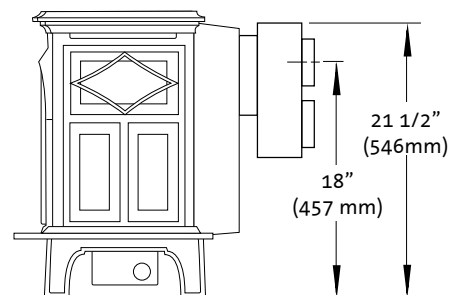

Figure 9. Co-Linear Adaptor dimensions with Plinth legs.

Masonry or Prefabricated Chimney Conversion

The GF200 DV Lillehammer is approved for use with Simpson Dura-vent Chimney Kit #934 in a masonry chimney or a prefabricated solid fuel listed chimney. These installation requirements must be followed:

1. In masonry chimney, a fireclay liner or listed steel liner, must be present the entire length of the chimney.
2. The liner must have an inside dimension of 6" round or greater. (USE KIT #934)
3. Prefabricated chimneys must be UL 103 or ULC S-629 listed and have a minimum INSIDE diameter of 6 inches, (150 mm). Prefabricated chimneys must be listed for the specific Simpson Dura-Vent Chimney Conversion Kit. (USE KIT #931, #932, or #933)
4. The Exhaust Restrictor plate, shipped with the stove, must be installed according to the instructions on page 8.

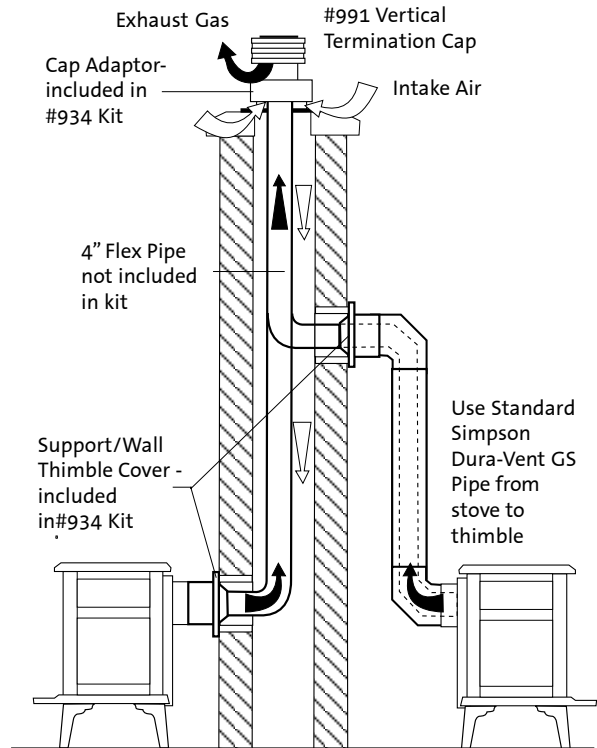

Figure 10. Vent System through a masonry chimney using the Simpson Dura-Vent Chimney Conversion Kit #934. May also be used in listed prefabricated chimneys. Drawing is for illustrative purposes only - **DO NOT VENT TWO APPLIANCES INTO A SINGLE CHIMNEY.**

IMPORTANT NOTICE

THE USE OF AN EXISTING CHIMNEY AS AN AIR INTAKE IS NOT COVERED UNDER THE ANSI Z21.88-1999-CSA 2.33-M99 TEST METHODS AND RESULTING ITS/WHI PRODUCT CERTIFICATION. THE CODE AUTHORITY HAVING JURISDICTION MUST BE CONSULTED PRIOR TO PROCEEDING WITH THIS INSTALLATION METHOD.

WARNING:

FAILURE TO POSITION THE PARTS AND STOVE IN ACCORDANCE WITH THESE DIAGRAMS OR FAILURE TO USE ONLY PARTS SPECIFICALLY APPROVED WITH THIS APPLIANCE MAY RESULT IN PROPERTY DAMAGE OR PERSONAL INJURY. BE SURE TO MAINTAIN THE PROPER CLEARANCES TO COMBUSTIBLES AS DEFINED IN THIS MANUAL AND IN THE INSTRUCTIONS PROVIDED WITH EACH SIMPSON DURA-VENT COMPONENT.

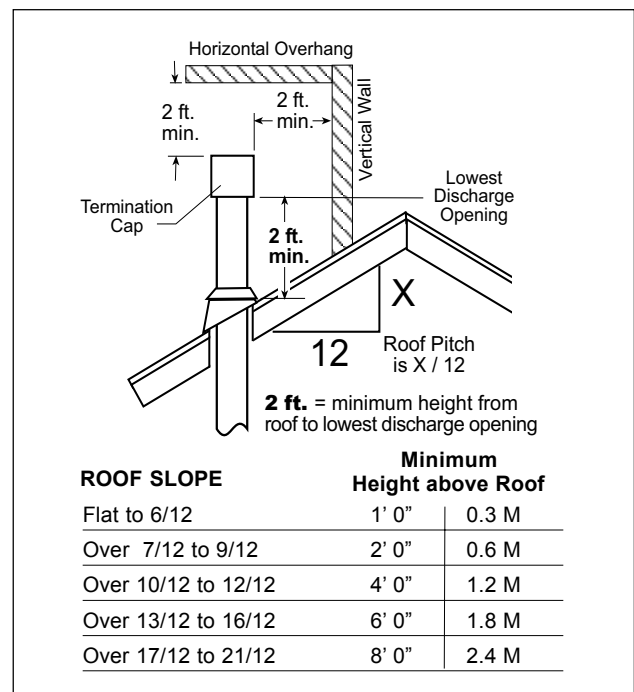

Figure 11. Gas Vent Height Rule: Vertical vent termination height above roof.

Horizontal Venting (Horizontal Termination)

- The maximum horizontal run made directly off the rear of the stove into a standard horizontal cap (#984 or #985) must be no more than a 9" section of Simpson Dura-vent (#907B). See Figure 12-1.
- The maximum horizontal run made directly off the rear of the stove into a 14" snorkel cap (#982) must be no more than a 24" section of Simpson Dura-vent (#904). See Figure 12-3.
- The horizontal termination cap must maintain a 3" clearance (80 mm) to any overhead combustible projections 2 1/2" (60 mm) or less. Maintain 12" (300 mm) clearance from projections exceeding 2 1/2". See Figure 13.
- Any horizontal run of vent must be level or have a 1/4" (5 mm) rise for every foot (300 mm) of run toward the termination cap. **DO NOT ALLOW THE VENT TO RUN DOWNWARD, AS THIS CAN CAUSE HIGH TEMPERATURES AND THE POSSIBILITY OF A FIRE.**
- A 1" (26 mm) clearance must be maintained around all co-axial vent pipe.
- For buildings with vinyl siding, a Vinyl Siding Standoff should be installed between the vent cap and the exterior wall (Simpson Dura-Vent #950). The Standoff prevents exposure of the vinyl siding to excessive heat that can damage the siding material.
- A 10" X 10" (250 mm x 250 mm) square hole is required to maintain proper vent clearances through a combustible wall. Simpson Dura-Vent Wall Thimble #942 installed according to the manufacturer's instructions meets clearance requirements.
- **DO NOT FILL AIR SPACE WITH ANY TYPE OF INSULATION.**
- Do not recess the termination cap into the exterior wall or siding.

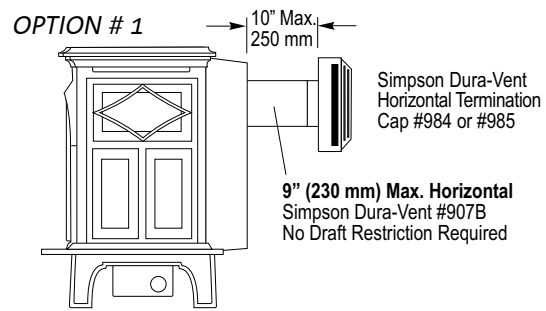

Figure 12-1. Maximum horizontal run to rear termination.

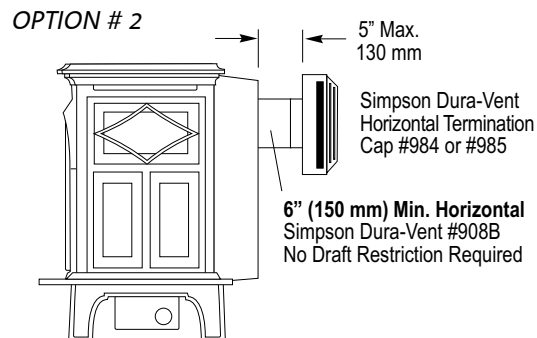

Figure 12-2. Minimum horizontal run to rear termination.

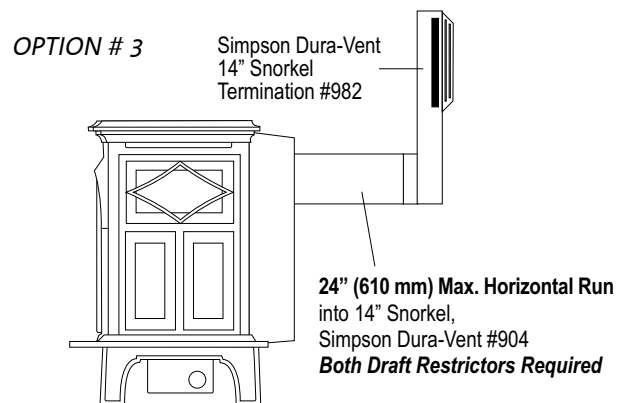

Figure 12-3. Maximum horizontal run to a snorkel termination.

IMPORTANT:
FOLLOW THE INSTALLATION INSTRUCTIONS PROVIDED WITH EACH SIMPSON DURA-VENT COMPONENT.

OPTION # 4

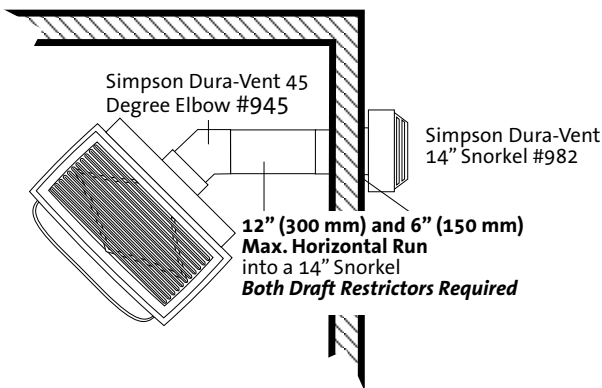

Figure 12-4. Maximum horizontal run with single elbow to a snorkel termination.

OPTION # 5

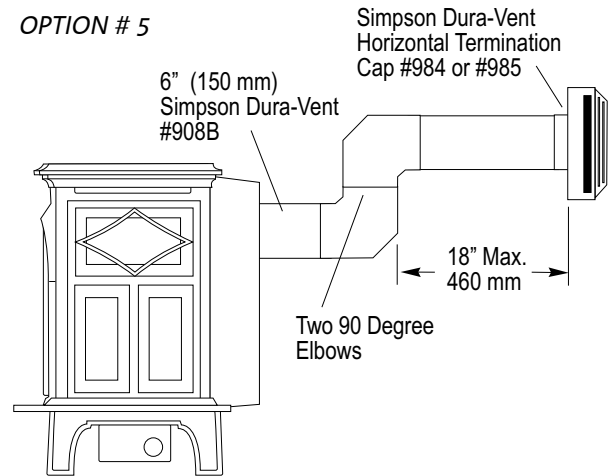

Figure 12-5. Horizontal vent with two elbows.

OPTION # 5

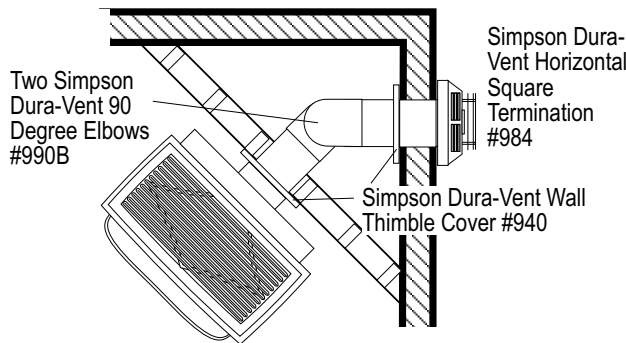

Figure 12-5a. Horizontal vent with two elbows.

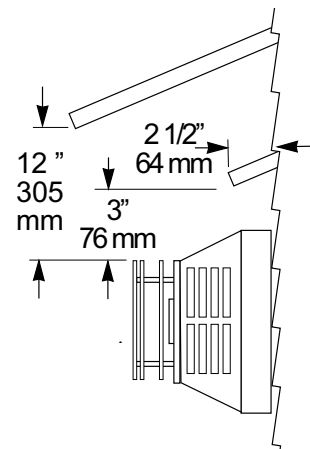

Figure 13. Termination clearances to exterior overhangs.

Wall Shield Installation

When horizontally venting directly off the rear of the stove, install the decorative Wall Shield #129349, (included in the stove), to cover the top of the venting hole in the wall. See Figure 14.

1. Remove the top four 1/4" hex head screw from the rear shroud of the stove.
2. Align the holes in the wall shield with the holes in the rear shroud.
3. Secure the wall shield to the stove with the four 1/4" hex head screws.

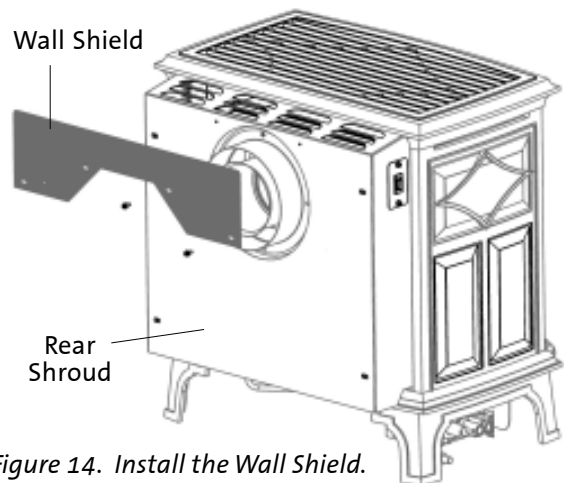

Figure 14. Install the Wall Shield.

Vent Termination Requirements

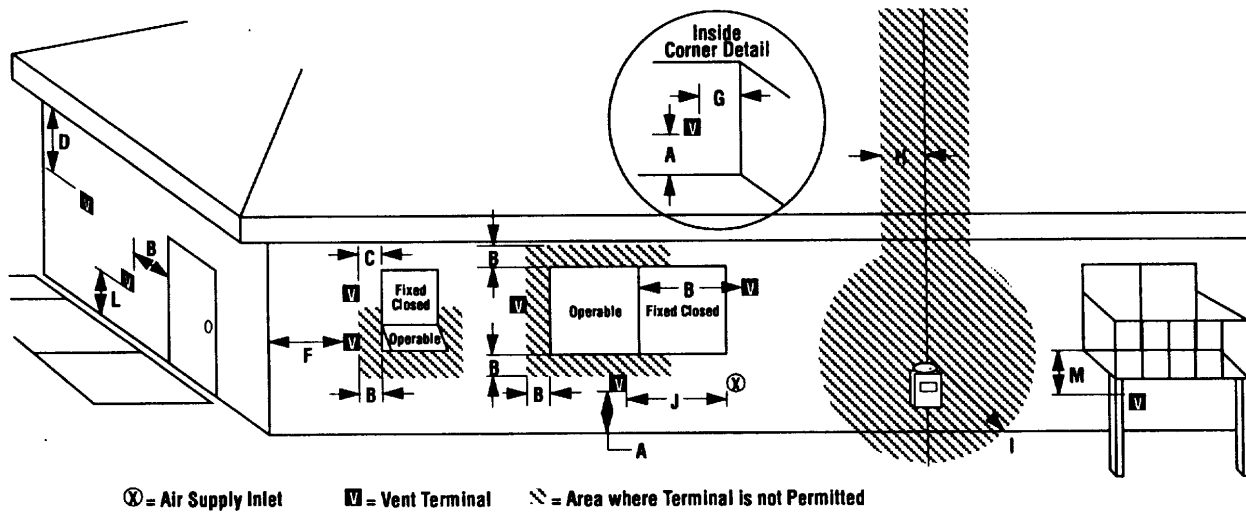

Figure 15. Vent Terminal Clearances - National Fuel Gas Code

A = Clearance above grade, veranda, porch, deck, or balcony: ***12 inches (30 cm) minimum.**

B = Clearance to window or door that may be opened: **9 inches (23 cm) minimum.** We recommend 12 inches to help prevent condensation.

C = Clearance to permanently closed window: **minimum 12 inches (30 cm)** recommended to prevent condensation on the window.

D = Vertical clearance to ventilated soffit located above the terminal within a horizontal distance of 2 feet (60 cm) from the centerline of the terminal: **18 inches (46 cm) minimum.**

E = Clearance to unventilated soffit: **12 inches (46 cm) minimum.**

F = Clearance to outside corner: **9 inches (23 cm) min.** Jøtul N.A. strongly recommends 12 inches (30 cm), particularly where windy conditions are prevalent.

G = Clearance to inside corner: **6 inches (16 cm) min.** Jøtul N.A. strongly recommends 12 inches (30 cm), particularly where windy conditions are prevalent.

H = *Not to be installed above a meter/regulator assembly **within 3 feet (90 cm)** horizontally from the center-line of the regulator.

I = Clearance to service regulator vent outlet: **6 feet (1.8 m) minimum.**

J = Clearance to nonmechanical air supply inlet to building or the combustion air inlet to any other appliance: ***12 inches (30 cm) minimum.**

K = Clearance to a mechanical air supply inlet: ***6 feet (1.8 m) minimum.**

L = ** Clearance above paved sidewalk or a paved driveway located on public property: ***7 feet (2.1 m) min.**

M = Clearance under veranda, porch, deck, or balcony: ***12 inches (30 cm) minimum.**¹

* As specified in CGA B149 Installation Codes. Note: Local Codes and Regulations may require different clearances.

** A vent shall not terminate directly above a sidewalk or driveway which is located between two single family dwellings and serves both dwellings.*

¹ Only permitted if veranda, porch, deck, or balcony, is fully open on a minimum of two sides beneath the floor.*

Mobile Home Installation

The Jøtul GF 200 DV Lillehammer can be installed for use in a mobile home in the U.S. and Canada provided:

1. The stove is secured to the floor of the mobile home. Use Jøtul Floor Mounting Kit #154342.
2. The stove is installed in accordance with Title 24 CFR, Part 3280- Manufactured Home Construction and Safety Standard, in the U.S. Comply with CSA Z240.4, Gas Equipped Recreational Vehicles and Mobile Housing, in Canada.
3. Always contact your local building code officials about installation restrictions and specific requirements in your area.

THIS APPLIANCE MAY BE INSTALLED AS AN OEM INSTALLATION IN A MANUFACTURED (MOBILE) HOME AND MUST BE INSTALLED IN ACCORDANCE WITH THE MANUFACTURER'S INSTRUCTIONS AND THE MANUFACTURED HOME CONSTRUCTION AND SAFETY STANDARD, TITLE 24 CFR, PART 3280. THIS APPLIANCE IS ONLY FOR USE WITH THE TYPE OF GAS THAT IS INDICATED ON THE STOVE'S RATING PLATE. A GAS CONVERSION KIT IS PROVIDED WITH THE LILLEHAMMER DIRECT VENT GAS STOVE.

THIS APPLIANCE MAY BE INSTALLED IN AN AFTERMARKET PERMANENTLY LOCATED, MANUFACTURED (MOBILE) HOME, WHERE NOT PROHIBITED BY LOCAL CODES.

CET APPAREIL PEUT ETRE INSTALLE DANS UN MAISON PREFABRIQUEE (MOBILE) DEJA INSTALLEE A DEMEURE SI LES REGLEMENTS LOCAUX LE PERMETTENT. CET APPAREIL DOIT ETRE UTILISE UNIQUEMENT AVEC LES TYPES DE GAS INDIQUES SUR LA PLAQUE SIGNALETIQUE. NE PAS L'UTILISER AVEC D'AUTRES GAS SAUF SI UN KITDE CONVERSION CERTIFIE EST INSTALLE.

Gas Conversion

The Jøtul GF 200 DV Lillehammer gas stove is shipped from the factory equipped to burn NATURAL GAS. Install the Fuel Conversion Kit, included with the stove, if Propane use is necessary. The kit contains all the necessary components needed for safe conversion and includes appropriate conversion notice labels.

WARNING:

THE CONVERSION KIT IS TO BE INSTALLED BY AN AUTHORIZED JØTUL SERVICE TECHNICIAN IN ACCORDANCE WITH THE MANUFACTURER'S INSTRUCTION AND ALL CODES AND REQUIREMENTS OF THE AUTHORITY HAVING JURISDICTION. FAILURE TO FOLLOW THESE INSTRUCTIONS COULD RESULT IN SERIOUS INJURY OR PROPERTY DAMAGE. THE QUALIFIED AGENCY PERFORMING THIS WORK ASSUMES RESPONSIBILITY FOR THIS CONVERSION.

Tools Required:

- 1/4" Nut driver
- 7/16" and 1/2" open end wrench
- Torx T-20 or slotted screwdriver.

Fuel Conversion Kit Contents:

- 1 regulator tower labeled for Propane
- 3 regulator tower screws
- 1 burner orifice (#48 for NG, 3/64 for LPG)
- 1 pilot orifice (#51 for NG, #30 for LPG)
- Label A - to be completed and applied to the back of the stove.
- Label B - to be applied to the stove Rating Plate.
- Small valve label - apply to the Control Valve body.

Conversion instructions are also included in the conversion kit.

Canadian Requirements

THE CONVERSION SHALL BE CARRIED OUT IN ACCORDANCE WITH THE REQUIREMENTS OF THE PROVINCIAL AUTHORITIES HAVING JURISDICTION AND IN ACCORDANCE WITH THE REQUIREMENTS OF THE CAN1-B149.1 AND .2 INSTALLATION CODE.

Gas Conversion Procedure

See Figure 29, page 25 for parts identification.

1. **Turn off gas supply** to the stove.
2. **Remove the stove Top Plate** (3).
3. **Remove the Front Panel.** Using a 10mm open-end wrench, loosen the two bolts holding the Front Panel (1) to the side panels (2). (Note: You do not have to remove these bolts.) Pull the Front Panel away from the stove and lift off of Bottom Plate.
4. **Release the Glass Retainer Clips** (12) on top of the firebox and carefully lift the Glass Panel up and out.
5. **Remove the Logs** (14) using care to avoid chipping or other damage.
6. **Lift out the Air Deflector** (17). Remove the Air Divider (16) by lifting right side and slowly rotating forward.
7. **Remove Burner Tube** (15): Using a 1/4" nut driver, remove the two screws securing the Burner Tube to the stove bottom. Lift out the Burner Tube. **WHEN RE-INSTALLING THE BURNER TUBE, BE SURE THAT THE TUBE IS PULLED FORWARD IN THE MOUNTING HOLES.** Secure with the two 1/4" screws.
8. **Remove the Burner Orifice Holder Shield** (18) around the orifice. Using a 1/4" nut driver remove the screw attaching the shield to the rear wall of the firebox. Slide the shield left and remove.
9. **Change the Main Burner Orifice** (38). Use a 1/2" open end wrench to remove the burner orifice and replace with the appropriate orifice supplied in the kit.
#48 for Natural Gas
3/64" for Propane
10. **Adjust the Air Shutter on the Burner Tube** (15) to allow for the proper mixing of air and gas. See fig. 16. The correct settings:

Open 1/8" for Natural Gas

Open 3/4" for Propane

11. **Change the Pilot Orifice.** From within the firebox, pull the Spring Clip back to release the Pilot Hood from the Pilot Base. Use the 4mm hex key to remove the original Pilot Orifice from the base, (counterclockwise). See fig. 17.

Install the appropriate pilot orifice:

#51 for Natural Gas

#30 for Propane.

Be certain the orifice is securely tightened. If the orifice is loose, gas flow will not be properly regulated.

Replace the Pilot Hood onto the base by re-engaging the spring clip around its collar.

12. **Replace the variable Regulator.** Using a Torx T-20 screwdriver, remove the three mounting screws

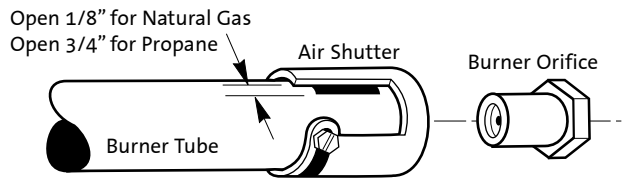

Figure 16. Air Shutter adjustment and Burner Orifice.

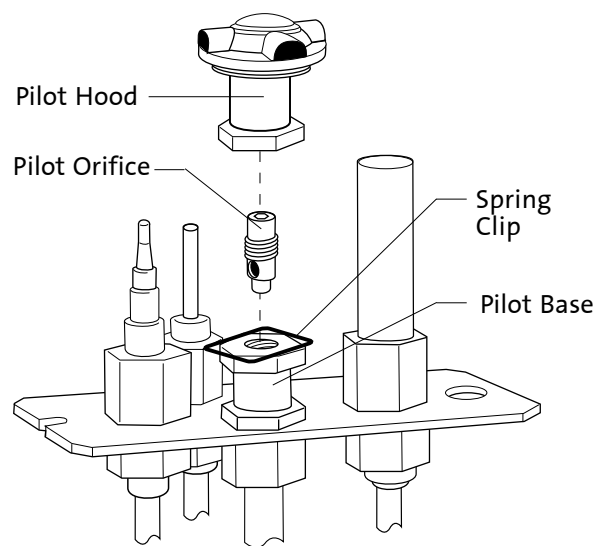

Figure 17. Pilot assembly and orifice.

- from the front of the valve Regulator. See fig. 18.
13. Remove the regulator tower and the gasket.
 14. Install the new variable regulator parts, confirming that the gasket is properly positioned. Replace the regulator cover and tighten the three screws securely.
 15. Apply the identification labels to locations as follows:
 - Label A - apply to back of stove.
 - Label B - apply to stove's rating plate.
 - Small Conversion Label - apply to valve.
 16. Reassemble the stove. Connect supply gas to the system and check for leaks using a soapy water solution.

WHEN RE-INSTALLING THE BURNER TUBE, BE SURE THAT THE TUBE IS PULLED FORWARD IN THE MOUNTING HOLES AND SECURED WITH THE TWO 1/4" SCREWS.

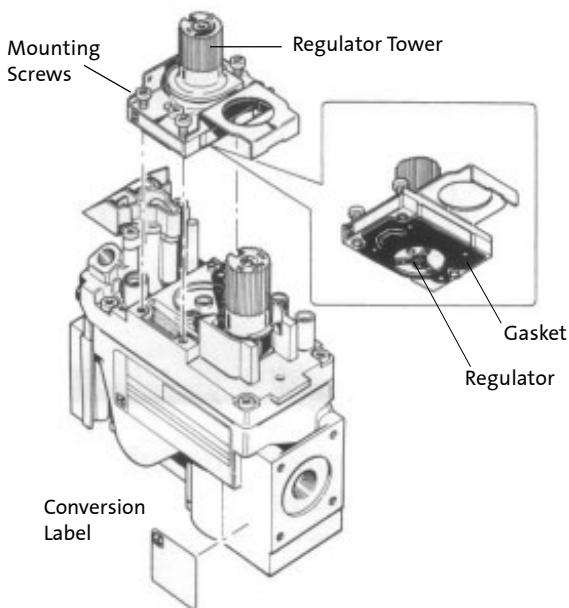

Figure 18. Regulator Assembly.

ALWAYS REFER TO THE LIGHTING INSTRUCTIONS ON THE BACK COVER OF THIS MANUAL WHEN LIGHTING YOUR LILLEHAMMER.

Connect the Gas Supply

The gas supply line connection is made to the valve just inside the left rear leg. The gas supply line should be 3/8" npt with a 1/2" diameter supply, or the appropriate size to provide sufficient gas pressure to the valve regardless of the input setting.

The use of Flexible Gas Appliance Connectors is acceptable in many areas in the U.S. However, Canadian methods vary depending on local code.

ALL INSTALLATIONS MUST COMPLY WITH LOCAL CODE OR IN THE ABSENCE OF LOCAL CODE, MUST COMPLY WITH THE MOST RECENT EDITION OF THE NATIONAL FUEL GAS CODE ANSI Z223.1/NFPA 54 OR CAN-B149.

All codes require a gas shut-off valve (gas cock) and union, to be installed in the supply line, and in the same room as the appliance. This allows for the disconnection of the stove for servicing and maintenance. See Figure 19.

T-HANDLE GAS COCKS ARE REQUIRED IN MASSACHUSETTS IN COMPLIANCE WITH CODE 248CMR.

Secure all joints tightly using appropriate tools and sealing compounds. For propane units be sure to use compounds that are propane resistant. Turn on gas supply and test for gas leaks using a soapy water solution.

NEVER USE AN OPEN FLAME TO CHECK FOR GAS LEAKS.

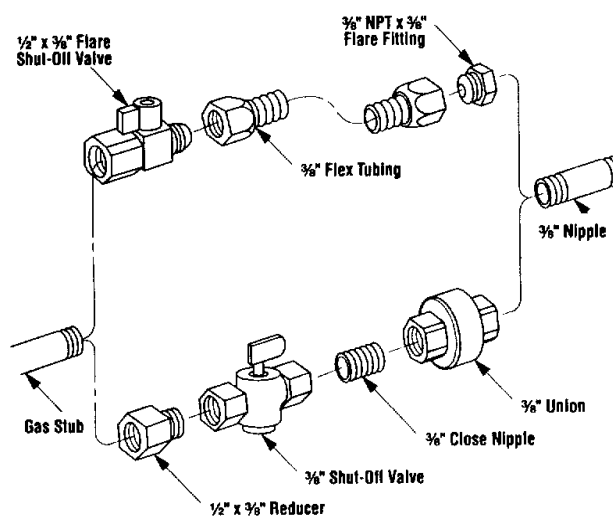

Figure 19. Supply Line Shut-off Valve Configurations.

Leak Test:

- Mix a 50-50 solution of water and dish soap.
- Light appliance- see lighting instructions on page 21 of this manual or on the stove's rating plate.
- Brush or spray all joints and connections with the soapy water solution.

If bubbles appear at any connection or seam or a gas odor is detected immediately turn gas control knob to the OFF position.

Tighten or reconnect the leaking joint and retest for any gas leaks.

Gas Pressure

Correct gas pressure is essential for efficient and safe operation of this appliance. It is important that the correct pressure is established at the time of the installation. Proper gas pressure provides a consistent flow of gas to the appliance and is instrumental in checking for gas leaks.

The gas control valve on the stove is equipped with pressure test points for gauge connections. It is possible then to test SUPPLY/INLET pressure and manifold pressure at the appliance.

Testing the available gas pressure should be done by attaching a manometer to the appropriate test point on the valve. The gauge connections are located on the front of the valve under the On/Off/Pilot- knob. Gauge connections are identified by:

E - for **Inlet** or supply pressure (the amount of gas coming to the valve.)

A - for **Manifold** pressure (the amount of gas that is coming out of the valve to the burner.) See fig. 20.

ALWAYS TEST PRESSURES WITH REGULATOR CONTROL KNOB SET ON HIGH.

Required Inlet Gas Pressures (in. W.C.)

	MIN.	MAX.
NATURAL GAS	5.0	7.0
PROPANE	11.0	13.5

The appliance and its main gas valve must be disconnected from the gas supply piping system during any pressure testing on that system at test pressures in excess of 1/2 psig (3.5kPa).

The appliance must be isolated from the gas supply line by closing its individual manual gas shut-off valve (gas cock) during any pressure testing of the gas supply piping system that is equal to or exceeds pressures of 1/2 psig (3.5kPa).

Required Manifold Pressure (in. W.C.)

	MIN.	MAX.
NATURAL GAS	2.2	3.5
PROPANE	5.5	10.0

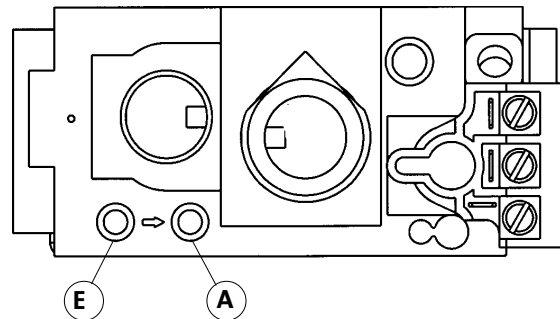

Figure 20. Supply and Manifold pressure test points.

High Altitude Adjustment

When installing the Lillehammer in high altitude (above 2500 ft.) locations, it becomes necessary to compensate for the thinner air (less volume of oxygen per cubic foot). High altitudes affect the atmospheric pressure and heat value of gaseous fuels. The lower oxygen content in the air and the lower gas viscosity require the use of a different orifice to achieve efficient, clean combustion at the burner tube.

U.S. Requirements

THE DERATING KIT MUST BE INSTALLED BY AN AUTHORIZED SERVICE TECHNICIAN IN ACCORDANCE WITH THE MANUFACTURER'S INSTRUCTIONS AND ALL CODES AND REQUIREMENTS OF THE AUTHORITY HAVING JURISDICTION. THE INFORMATION STICKER MUST BE FILLED OUT BY THE INSTALLER AND ADHERED TO THE APPLIANCE AT THE TIME OF THE CONVERSION. THE QUALIFIED SERVICE AGENCY PERFORMING THIS WORK ASSUMES RESPONSIBILITY FOR THIS DERATING.

Canadian Requirements

This unit has been tested for installation at high altitudes in accordance with Canadian test standard CAN/CGA-2.17.

THE DERATING SHALL BE CARRIED OUT IN ACCORDANCE WITH THE REQUIREMENTS OF THE PROVINCIAL AUTHORITIES HAVING JURISDICTION AND IN ACCORDANCE WITH THE REQUIREMENTS OF THE CAN1-B-149.1 AND .2 INSTALLATION CODE.

For installations from 610 - 1370 meters (2000-4500 ft.) the orifice size for natural gas is #49 and for propane gas #56. SEE THE HIGH ALTITUDE ORIFICE CHART

See the Rating Plate for additional information. For high altitude installations, consult the local gas distributor or the authority having jurisdiction for proper rating methods. If the installer must convert the unit to adjust for varying altitudes, the information sticker must be filled out by the installer and adhered to the appliance at the time of the conversion.

Derating Procedure:

To derate this unit, install the appropriate orifice as shown in the High Altitude chart.

1. Remove the two 1/4" hex head screw that holds the burner tube/log support to the bottom of the stove.
2. Remove the burner tube/log support to expose the main burner orifice.
3. Remove the air deflector shield around the main burner orifice.
4. Remove the orifice and replace with the appropriate one from the high altitude kit.
5. Be sure to attach the high altitude conversion sticker provided with the kit to the rating plate on the appliance.

GAS TYPE	ORIFICE SIZE	ELEVATION	PART NUMBER
NATURAL GAS	#48	0-2000' (0-610m)	129407
NATURAL GAS	#49	2001-4500' (611-1370m)	129411
PROPANE GAS	3/64	0-2000' (0-610m)	129409
PROPANE GAS	#56	2000-4500' (611-1370m)	154373

Table 3. High Altitude Orifice Chart.

A self-adhesive Conversion Label (Fig. 21) is included with the High Altitude Kit. Apply this label to the control valve after it has been converted for high altitude.

THIS STOVE HAS BEEN CONVERTED FOR USE AT AN ALTITUDE OF _____

Orifice Size _____ Manifold Press: _____

Input BTU/Hr. _____ Fuel Type _____

Date of Conversion _____

Figure 21. High Altitude Conversion Label.

Air Shutter Adjustment / Flame Picture

The Lillehammer is shipped from the factory equipped to use NATURAL GAS. When converted for use with propane gas, the air shutter on the burner tube must be adjusted to achieve the proper gas to air mix.

Air Shutter Settings: See Figure 22.

1/8" open for Natural Gas

3/4" open for Propane

The air shutter can also help achieve the desired flame appearance. Generally, flame appearance is a matter of preference, however most consumers enjoy the warm yellowish flame.

Too large a setting - the appliance will generate a flame that is blue and transparent, or an "anemic" flame.

Too small a setting - the appliance will generate very long yellow flames resulting in soot. Sooting produces black deposits on the logs, on the inside walls of the appliance, and potentially on the exterior termination cap.

Sooting is caused by incomplete combustion in the flames and lack of combustion air entering the air shutter opening.

To adjust the air shutter, remove the burner tube and using a phillips head screwdriver loosen the screw at the air shutter and adjust accordingly. Be sure to retighten the screw that holds the air shutter setting. Reassemble the stove and close the door, allow stove to burn 30 minutes on the HIGH setting, observing the flame continuously. If the flame appears weak, slow, or sooty, repeat the process described above until the flame is as desired.

Recommended Air Shutter Settings:

Natural Gas - 1/8" open

Propane - 3/4" open

WARNING:
AIR SHUTTER ADJUSTMENTS SHOULD
ONLY BE PERFORMED BY A
QUALIFIED PROFESSIONAL SERVICE
TECHNICIAN.

NOTE: Air shutter should never be LESS than 1/8" open.

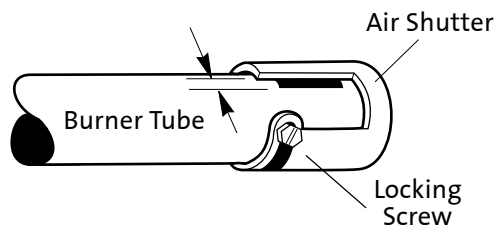

Figure 22. Air shutter opening.

Install the Log Set

The Lillehammer is equipped with a one piece log set and is packaged in bubble wrap inside the firebox. The log set must be removed from the packaging and arranged in the unit prior to start up of the gas stove. Do not handle the log set with your bare hands. Always wear gloves to prevent skin irritation from the ceramic fibers.

To install the log set, remove the packaging and place the log set inside the firebox, centered from left to right and completely against the rear wall of the stove. See Figure 23.

A package of Glow Embers is included with the Log Set. These are to be placed across the burner tube on the screen. It is best to equally space these embers for optimum flame appearance. Note: All of the embers do not have to be used.

Use work gloves to handle the ceramic logs and and Glow Embers. These parts can irritate skin. If contact and irritation occurs, gently wash your hand with a mild soap and warm water.

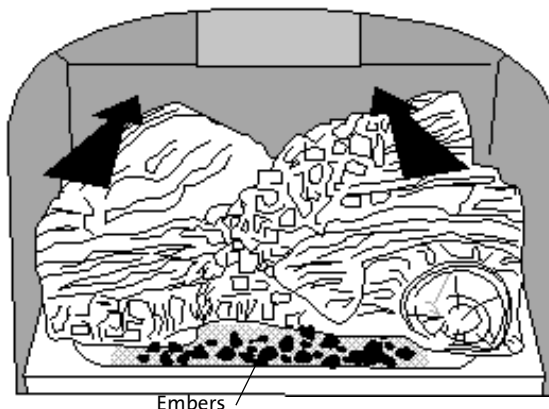

Figure 23. Seat log set against rear wall.

Installing the Optional Wall Thermostat of Remote Control

When installing a wall mounted thermostat to the Lillehammer, it must be 750 millivolt DC two-wire circuit thermostat. The thermostat should be placed in the same room as the heater, typically 5' off the floor. Avoid drafty areas or any area that may affect the accuracy of the thermostat.

The thermostat should be connected to the Lillehammer using a minimum of 16 gauge wire with a maximum length of 35 feet of wire.

Connect the two thermostat wire leads to the two lower terminals on the terminal block located directly above the ignitor button. Do not over-tighten the connections. IT IS NOT NECESSARY TO DISCONNECT ANY OTHER WIRES. See Figure 24.

For the thermostat to work, the On/Off/T-Stat switch on the back of the stove must be in the T-stat position, and the pilot light must be running, as it is the power source for the thermostat.

At the thermostat the two wires should be connected to the two connections screws on the thermostat base plate per the manufacturers instructions.

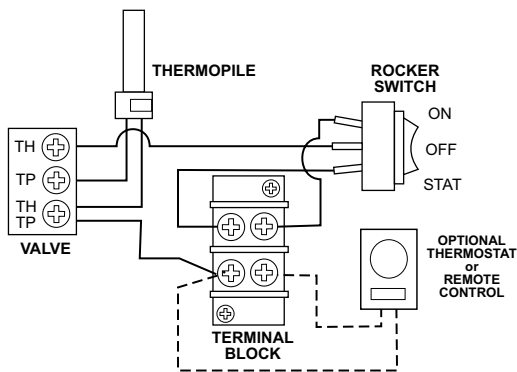

Figure 24. Thermostat / Remote Control Wiring Diagram.

Remote Control

When using a remote, the remote receiver should be wired to the terminal block the same way the thermostat would be. See the instructions above.

CAUTION:

LABEL ALL WIRES PRIOR TO DISCONNECTION WHEN SERVICING THE CONTROLS. WIRING ERRORS CAN CAUSE IMPROPER AND DANGEROUS OPERATION. ALWAYS VERIFY PROPER OPERATION AFTER SERVICING THE APPLIANCE.

Checking the System

- 1. Purging the Gas Line:** When lighting the appliance for the first time it will take a few moments to clear the gas line of air. Once this purge is complete, the appliance will operate as described in the lighting instructions located on the stove's rating plate. All subsequent lightings of the stove will not require such purging of the gas line.
- 2. Pilot Flame:** The pilot flame should be steady, not lifting or floating. The flame should be blue in color around the pilot hood, with traces of yellow toward the outer edges.

It is imperative that the pilot flame engulf the top 3/8" of the thermopile (power generator) and the top 1/8" of the quick drop out thermocouple. The pilot flame should project out of the pilot hood 1" at all three ports. See Figure 25.

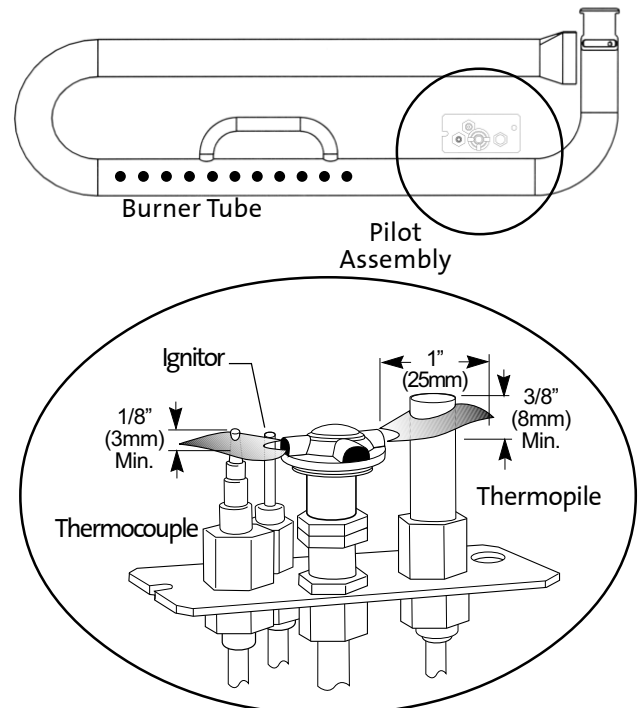

Figure 25. Pilot Location and Correct Appearance

Operation of Appliance

3. Burner Adjustment: The Lillehammer is equipped with a variable gas control valve that provides easy adjustment of the flame height appearance and heat output. To adjust the flame between the HI and LOW setting, rotate the HI/LOW knob, located in the center of the valve face. **Flame height will adjust approximately 1.0" to 1.5" between the LOW and HIGH settings.** See Figure 26.

NO SMOKE OR SOOT SHOULD BE PRESENT. CHECK LOG PLACEMENT IF ANY SOOT OR SMOKE IS DETECTED. IF SOOT OR SMOKE PERSIST, THE AIR SHUTTER MAY NEED TO BE ADJUSTED.

See Air Shutter/Flame Appearance section of this manual for proper air shutter settings and adjustments. Note: the more offsets on the vent system, the greater the need for an air shutter adjustment.

WARNING: AIR SHUTTER ADJUSTMENTS SHOULD ONLY BE PERFORMED BY A QUALIFIED PROFESSIONAL SERVICE TECHNICIAN.

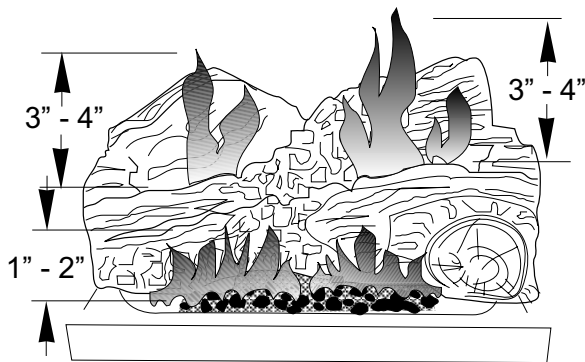

Figure 26. Correct flame picture.

The illustration above depicts the flame appearance on the "high" setting after burning approximately 15 to 20 minutes.

CAUTION: DO NOT ATTEMPT TO ALTER THE FLAME APPEARANCE BY POSITIONING THE GAS VALVE IN ANY OTHER POSITION OTHER THAN THE FULL "ON" POSITION.

1. Always follow the Safety Guidelines and Lighting Instructions found on page 27 (inside back cover). These instructions are also found on the metal Rating Plate attached to the stove.
2. The Lillehammer is equipped with an On/Off/T-stat rocker switch or can be controlled using an optional wall mounted thermostat.
3. When lit for the first time, the Lillehammer will emit an odor for several hours. This odor is the burn-off by-products of internal paints and lubricants used in the manufacturing process.
4. Condensation may occur on the glass upon each lighting of the appliance. This "fog" will disappear as the appliance heats up.
5. Keep the controls and the area under the appliance free of debris, vacuum this area frequently. Always keep the appliance area clear and free from combustible materials, gasoline and other flammable liquids.

If and when a vacuum is used for any service on the stove, ALWAYS be sure the stove is cold and that there are NO hot embers or sparks.

6. Remember, this appliance has a continuous burning pilot flame. Exercise caution when using products with combustible vapors. Always shut-off the gas supply while servicing the stove.
7. **CAUTION: DO NOT OPERATE THIS APPLIANCE WITH THE GLASS REMOVED CRACKED OR BROKEN.** Replacement of the glass should be done by a licensed or qualified service person. Use only replacement glass provided by your authorized Jøtul dealer. Never use any substitute materials.
8. Clean the glass only when necessary. Wipe surface with a clean, dampened, soft cloth. Follow with a dry, soft towel as desired. Take care not to scratch the glass surface.

WARNING: DO NOT USE ABRASIVE CLEANERS ON THE GLASS. NEVER CLEAN THE GLASS WHEN IT IS HOT.

Maintenance

The GF 200 DV Lillehammer gas stove and its venting system should be inspected before use and at least annually by a qualified service technician.

IMPORTANT:
ALWAYS TURN OFF THE GAS SUPPLY TO THE STOVE BEFORE ANY SERVICE WORK IS PERFORMED ON THE STOVE.

General cleaning: The firebox should be vacuumed out annually to remove any surface build up. Be sure to vacuum or wipe off the pilot assembly and burner orifice and burner tube. Also, when vacuuming the log set, be sure to handle it carefully as it is very fragile.

Gasket inspection: It is important that the glass gasket be inspected at least annually. Examine the rope gasket for signs of deterioration and make sure the gasket has a positive seal. This is important to prevent combustion gases from escaping into the room. Replace the gasket if necessary, refer to the replacement parts list on page 25.

Always replace any damaged or broken parts with JØTUL AUTHORIZED PARTS ONLY. These are available through your Jøtul dealer. Never use any substitute parts on your Lillehammer Direct Vent stove.

With proper care and maintenance, your Jøtul gas stove will provide you with many years of service. If you experience any problems with Jøtul GF 200 DV, contact your authorized Jøtul dealer for assistance.

Fill out the Maintenance Record form on the next page and keep it up to date. It will provide useful information of service activity to help you and your dealer keep your stove in top condition.

RETAIN THIS MANUAL FOR REFERENCE AND MAKE IT AVAILABLE TO ANYONE USING OR SERVICING THE STOVE.

WARNING: OBSERVE CAUTION NEAR THE GLASS. THE GLASS PANEL MAY SHATTER UNEXPECTEDLY IF STRUCK WITH AN OBJECT. ALWAYS HANDLE THE GLASS PANEL WITH CARE. WHEN SERVICING THE STOVE ALWAYS PULL THE GLASS ASSEMBLY STRAIGHT UP FOR REMOVAL.

Glass Front

Do not operate the Lillehammer gas stove with the glass front removed, cracked or broken. Replacement of the glass should be done by a licensed or qualified service person. Only remove glass for routine service. Always handle glass carefully.

Glass and Gasket Replacement

1. Using a nail punch inserted into the perf holes, carefully pry the two glass retainer tabs back. See fig. 27.
2. Peel away all remnants of the old gasket material and clean any adhesive residue off the glass.
3. Peel the paper backing off the replacement gasket to expose the adhesive.
4. Apply the gasket to the panel, wrapping the adhesive side down around the panel edge. See fig. 28.
5. Insert the gasketed glass panel into the frame and use the nail punch to bend the retainer tabs over the edge.

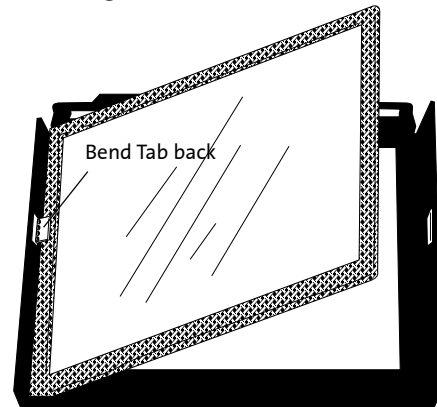

Figure 27. Glass removal.

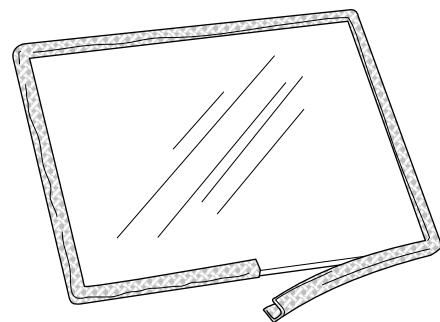

Figure 28. Glass gasket replacement.

Maintenance Record

**Jøtul GF 200 Lillehammer
Direct Vent Stove**

Model:

Serial Number: _____

Date of Purchase: _____

Dealer: _____

Address: _____

Phone: _____

Type of Fuel: Natural Gas Propane

Fuel Conversion? YES NO

Installer: _____

Service Date: _____

Service Notes:

Service Date: _____

Service Notes:

Service Date: _____

Service Notes:

Illustrated Parts List

GF 200 DV Lillehammer

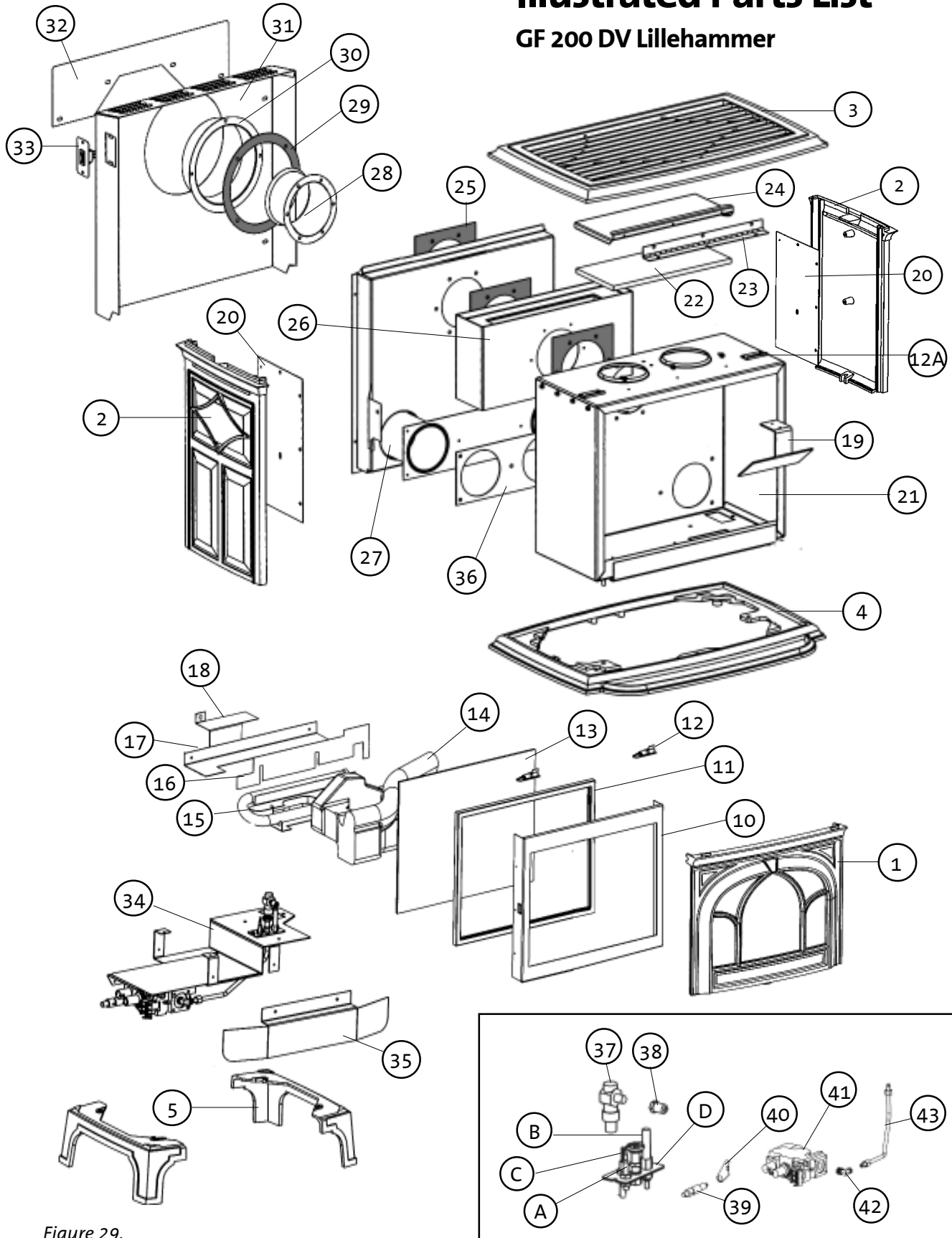

Figure 29.

Painted & Enamelled Cast Iron Parts

CASTING	Matte Black	Blue Black	Ivory	Forest Green	Jøtul Iron		
1	Front Panel	103905	10390527	10390529	10390536	10390585	NOTE: ONLY USE GENUINE JØTUL REPLACEMENT PARTS PRO- VIDED BY AN AUTHORIZED JØTUL DEALER.
2	Side Panel	103907	10390727	10390729	10390736	10390785	
3	Top Casting	103906	10390627	10390629	10390636	10390685	
4	Bottom Plate	103900	10390027	10390029	10390036	10390085	
5	Leg Plinth	103908	10390827	10390829	10390836	10390885	

Firebox Assembly		Part No.
10	Glass Frame	12931692
11	Glass Gasket (7/16" tadpole)	129124
12	Glass Clip	129135
	Glass Frame Assembly	154337
12A	Latch Keeper	129149
13	Glass	129113
14	Log Set	129122
*	Embers	129123
15	Burner Tube	129331
16	Air Divider	129320
17	Air Deflector	129109
18	Burner Orifice Holder Shield	129329
19	Exhaust Baffle	129310
20	Side Heat Shield	129317
21	Firebox	129300
22	Relief Door Gasket	129319
23	Relief Door Hinge/Spring	129373
24	Relief Door	129314
25	Heat Exchanger Gasket	129313
26	Heat Exchanger	129302
27	Air Intake Manifold	129306
28	4" Pipe Collar	129321
29	Starter Gasket 6.6"	129118
30	6.6" Pipe Collar	129322
31	Rear Shroud	129311
32	Wall Shield	129349
33	On/Off/T-stat Switch	129153
*	Switch Heat Shield	129342
*	Wiring Harness, complete	154339
34	Valve Bracket	129105
35	Valance	129106
36	Air Manifold Gasket	129119
37	Orifice Holder	129128
*	Jam Nut, for holder	129152
38	Burner Orifice - NG #48	129407
*	Burner Orifice - LP 3/64	129409
A	Thermocouple	129447
B	Thermopile	3094527
C	Electrode	129173
D	Pilot Assembly w/NG orifice (PopTop)	129471
*	Gasket Pilot Assembly	129116

* not illustrated

Firebox Assembly	Part No.	
*	Pilot Orifice - NG #51	129472
*	Pilot Orifice - LP #30	129473
*	Pilot Line	129446
*	Terminal Block	129154
39	Ignitor Button	3902573
40	Ignitor Bracket	3902576
41	Valve NG	3902159
*	Valve LP	3902160
42	Brass Valve Elbow (3/8"NTP to 5/8")	129129
43	Main Gas Line (flexible)	129462
*	Exhaust Restrictor	129344
*	Air Intake Restrictor	129347
*	Spud Plate Assembly	154336

Hardware List	Part No./Qty.
Leg Plinth - M6 X 20 Bolts	117117 4
Washers	120004 4
Front-to-Sides - M6 X 20 Bolt	117117 2
Washers	120004 4
Sides-to-Base - M6 X 25 Bolt	9905 2
Washers	120004 2
Heatshield -to-Sides M6 X 12 Bolt	117130 4
Valve-to-Bracket	117911 4
Ignitor Bracket-to-Valve (M4 X 8 philips)	117920 1
Pilot Assembly-to-Valve Bracket (#8)	117917 2
Firebox-to-Base - Nut only M6	9930 2
On/Off Assembly-to-Rear Shroud (#8)	117917 1
Starter Elbow to firebox (#10X1/2)	117917 4
Valance Screws (#10 X 1/2)	117917 2
Retainer Clip	117965 1

Accessories	Part No.
Wall Thermostat	750003
Remote Control Model L	750002
Mobile Home Floor Bracket Kit	154342
Fuel Conversion Kit - NATURAL	155349
Fuel Conversion Kit - PROPANE	155350
Torx T-20 Screwdriver	110002

To order replacement parts, contact your local Authorized Jotul Dealer. Parts and specifications are subject to change without notice.

LIGHTING INSTRUCTIONS

FOR YOUR SAFETY, READ BEFORE LIGHTING.

WARNING:

IF YOU DO NOT FOLLOW THESE INSTRUCTIONS EXACTLY, A FIRE OR EXPLOSION MAY RESULT CAUSING PROPERTY DAMAGE, PERSONAL INJURY, OR LOSS OF LIFE.

- A.** This appliance has a pilot which must be lit by hand. When lighting the pilot, follow these instructions exactly.
- B. BEFORE LIGHTING**, smell all around the appliance area for gas. Be sure to smell next to the floor because some gas is heavier than air and will settle to the floor.
- WHAT TO DO IF YOU SMELL GAS:**
- Extinguish any open flame.
 - Open windows.
 - Do not light any appliance.
 - Do not touch any electrical switches.
 - Do not use any phone in your building.
- Immediately call your gas supplier from a neighbor's phone.
 - If your gas supplier cannot be reached, call the fire department.
- C.** Use only your hand to push in or turn the gas control knob. Never use tools. If the knob will not push in or turn by hand, do not try to repair it. Call a qualified technician. Force or attempted repair may result in a fire or explosion.
- D.** Do not use this appliance if any part has been under water. Immediately call a qualified service technician to inspect the appliance and to replace any part of the control system and any gas control which has been under water.

LIGHTING INSTRUCTIONS

1. STOP! Read the safety information above.
2. Access the lower controls.
3. Turn the stove ON/OFF switch to "OFF", or set the thermostat to lowest setting (if used).
4. Confirm that the gas supply line shut-off valve is open.
5. Push in gas control knob slightly and turn clockwise to "OFF".

NOTE: Knob cannot be turned from "PILOT" to "OFF"

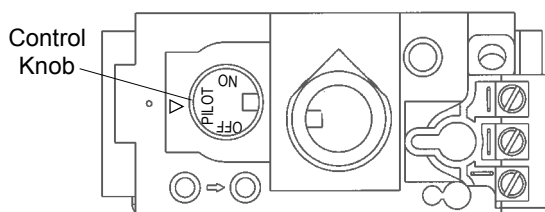

CONTROL VALVE

unless the knob is pushed in slightly. Do not force.

6. Wait five (5) minutes to clear out any gas. If you then smell gas, STOP! Follow "B" in the safety information above on this page. If you do not smell gas, go to the next step.

7. Push in gas control knob slightly and turn counterclockwise  to "PILOT".
8. Push in control knob all the way and hold in. Immediately light the pilot by triggering the spark ignitor (push the red button repeatedly) until pilot lights. Continue to hold the control knob in for about one minute after the pilot lights. Release knob and it should spring back. The pilot should remain lit. If it goes out, repeat Steps 5 through 8.

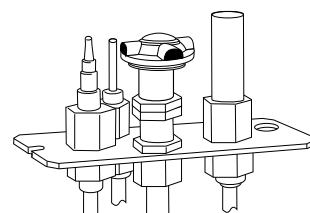

PILOT ASSEMBLY

- If knob does not return when released, stop and immediately call your service technician or gas supplier.
 - If pilot will not stay lit after several tries, turn the control knob to OFF and call your service technician or gas supplier.
9. Turn gas control knob counterclockwise  to "ON".
 10. Turn the stove ON/OFF switch to "ON", or set thermostat (if used) to desired temperature.

TO TURN OFF GAS TO THE APPLIANCE:

1. Turn ON/OFF switch to "OFF". The pilot will remain lit for normal service.
2. For complete shutdown, turn ON/OFF switch to "OFF".
3. Access the lower controls.
4. Depress gas control knob slightly and turn clockwise  to "OFF". Do not force.



Stoves and fireplaces must be installed to conform to local and national building regulations. In preparing to install this appliance, it is important that all instructions issued with the unit are carefully read and strictly followed. Jøtul pursues a policy of continual product development. Products supplied may therefore differ in specification, color and type of accessories from those illustrated and described in various publications.

..

Jøtul vise sans cesse a ameliorer ses produits. C'est pourquoi, il se reserve le droit de modifier les specifications, couleurs etequipement sans avis prelable.

Jøtul ASA

P.O. Box 1411
N-1602 Fredrikstad, Norway

Jøtul North America

400 Riverside Street
Portland, ME 04104