



Radio | CD | SD/MMC | MP3

Bremen MP76

7 646 828 310

Operating instructions





<http://www.blaupunkt.com>

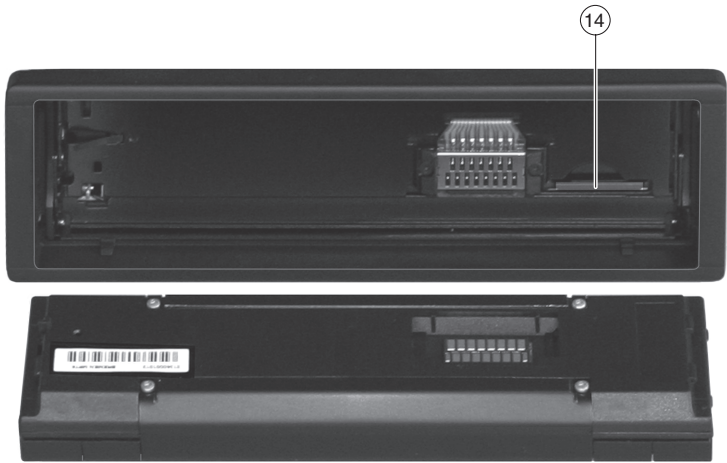
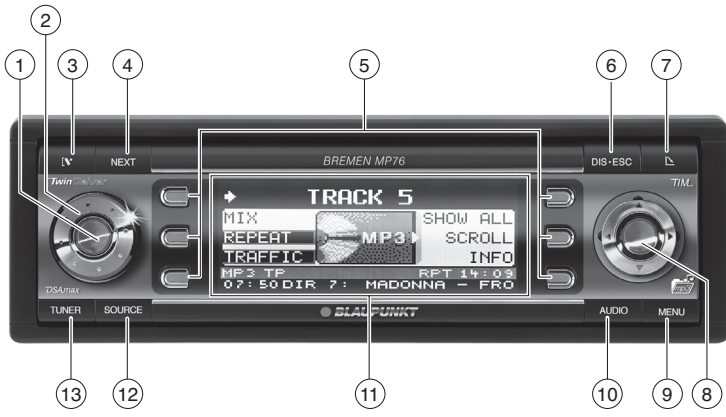

BLAUPUNKT



- ① Button to switch the device on and off
Muting the device
- ② Volume control
- ③  button to unlock the detachable control panel
- ④ **NEXT** button to display additional pages of a menu
Changing the memory bank in radio mode
- ⑤ Softkeys, the function of the softkeys is dependent upon the respective content of the display
- ⑥ **DIS•ESC** button to change the display and exit menus
- ⑦  button to open the foldable and detachable control panel
- ⑧ Joystick and **OK** button
- ⑨ **MENU** button to call up the menu for the basic settings (short press)
Switching demo mode on/off (long press)
- ⑩ **AUDIO** button for setting bass, treble, balance, fader and X-BASS (short press)
Calling up DSA Max equalizer (long press)
- ⑪ Display
- ⑫ **SOURCE** button to start the CD or CD changer playback or Compact Drive MP3 (only if connected) or to start the radio mode
or
Playback of an external audio source (only if connected)
- ⑬ **TUNER** button for direct selection of radio mode
Calling up the radio function menu (only possible in radio mode)
- ⑭ Slot for MMC/SD

Notes and accessories.....	58	Radio mode	68
Disposal of old unit		Adjusting the tuner.....	68
(EU countries only)	58	Setting the number of antennas	68
Road safety.....	58	Switching to radio mode	69
Safety note	58	Selecting static/dynamic radio	
Installation.....	58	mode (FM only)	69
Optional equipment (not part of the		Convenient RDS functions (AF, REG)....	70
scope of delivery)	58	Selecting the waveband/	
Activating/deactivating demo mode..	59	memory bank	71
Theft protection	59	Tuning into a station	72
Detachable control panel	59	Setting the sensitivity of station	
Detaching the control panel.....	59	seek tuning	72
Attaching the control panel.....	60	Scanning receivable stations (SCAN) .	73
Switching on/off.....	60	Setting the scanning time.....	73
Switching on/off using button ① ...	60	Storing stations	73
Switching on/off using the vehicle		Storing stations automatically	
ignition.....	60	(Travelstore)	73
Volume	61	Listening to stored stations	74
Setting the power-on volume	61	Programme type (PTY)	74
Risk of injury!	61	Optimising radio reception	75
Mute.....	61	Activating/deactivating the radio	
Telephone audio	61	text display	75
Navigation audio	62	TIM – Traffic Information Memory.....	76
Sound and volume relationship.....	63	Switching TIM on/off	76
Adjusting the bass	63	Playing stored traffic announcements...77	
Adjusting the treble.....	63	Recording traffic announcements.....	77
Setting the left/right volume ratio		Setting the timer	78
(balance).....	64	Selecting timers	78
Adjusting the front/rear volume		Traffic information.....	79
ratio (fader)	64	Switching traffic information	
X-BASS	64	priority on/off	79
Display.....	65	Setting the volume for traffic	
Adjusting the viewing angle	65	announcements.....	79
Adjusting the display brightness.....	65	CD mode	80
Setting the button illumination colour ..65		Risk of severe damage to	
Setting the display illumination		the CD drive!	80
colour	66	Starting CD mode, inserting a CD	80
Adjusting the spectrum analyser	67	Ejecting a CD.....	80
Inverting display contents	67	Selecting tracks.....	80
		Fast searching (audible).....	81

Random track play (MIX)	81	Manually changing the graphical equalizer	94
Repeating tracks (REPEAT)	81	Selecting the Equalizer	95
Scanning tracks (SCAN).....	81	Resetting the equalizer	95
Displaying CD text.....	81	Selecting a sound presetting (Preset) ...	95
Adjusting the scrolling text	82	Adjusting the stage effect.....	96
Traffic announcements in CD mode ..	82	Selecting a sound effect.....	96
MP3 mode.....	82	DNC.....	97
Preparing an MP3 CD	82	Calibrating DNC.....	97
Inserting/removing MMCs/SDs	83	Switching DNC off.....	97
Inserting an MMC/SD	84	Selecting a DNC increase	98
Removing an MMC/SD	84	Subwoofer and centre speaker	98
Switching to MMC/SD mode.....	84	Adjusting the subwoofer increase.....	98
Activating the MP3 mode of CD.....	84	Adjusting the subwoofer phase position.....	99
Operation during the MP3 mode	84	Setting the low-pass filter.....	99
Selecting tracks.....	85	Setting the subsonic filter	99
Fast searching (audible).....	85	Adjusting the centre speaker	100
Scanning tracks (SCAN).....	86	Adjusting high-pass filters for front/rear	100
Random track play (MIX)	86	Crossover	101
Repeating individual tracks or whole directories (REPEAT).....	86	TMC for dynamic navigation systems	101
Configuring the display	86	Amplifier/Sub-Out	102
CD changer mode (optional).....	88	Switching the internal amplifier on/off	102
Switching to CD-changer mode	88	External audio sources	102
Selecting CDs.....	88	Switching the AUX input on/off	103
Selecting tracks.....	88	Naming the AUX input.....	103
Fast searching (audible).....	88	Miscellaneous	104
Scanning tracks (SCAN).....	88	Entering a switch-on message.....	104
Repeating individual tracks or whole CDs (REPEAT)	89	Displaying the serial number.....	104
Random track play (MIX)	89	Resetting the device.....	104
Naming CDs	89	Specifications	105
Clock - time	91		
Setting the time	91		
Permanent time display	92		
DSA Max -Digital Sound Adjustment ...	92		
Switching DSA on/off	92		
Automatically calibrating the equalizer	93		
Viewing vehicle acoustics with/ without equalizer	94		

Notes and accessories

Please read these operating instructions before using the equipment for the first time.

We provide a manufacturer's warranty for our products purchased within the European Union. The warranty terms can be called up under www.blaupunkt.de or requested directly from:

Blaupunkt GmbH
Hotline
Robert Bosch Str. 200
D-31139 Hildesheim

Disposal of old unit (EU countries only)

 Do not dispose of your old device in the household trash!

Use the return and collection systems available to dispose of the old device.



Road safety

Road safety has absolute priority.

- Only operate your car sound system if the road and traffic conditions allow you to do so.
- Familiarise yourself with the device before setting off on your journey.

You should always be able to hear police, fire and ambulance sirens in good time from inside your vehicle.

- For this reason, listen to your car sound system at a suitable volume level during your journey.
-



Safety note

The car sound system and the control panel of the device (flip-release panel) warm up during operation.

- For this reason, touch the flip-release panel only at non-metallic surfaces for removal purposes.
 - If you want to uninstall the car sound system, let it cool down first.
-

Installation

If you want to install your car sound system yourself, please read the installation and connection instructions that follow these operating instructions.

Optional equipment (not part of the scope of delivery)

Only use accessories approved by Blaupunkt.

Remote control

The remote control RC 08, RC 10 or RC 10H (available as optional equipment) allows you to safely and conveniently operate most of the basic functions of your car sound system.

You cannot switch the device on/off using the remote control.

Amplifiers

You can use all Blaupunkt and Velocity amplifiers.

CD changers

The following CD changers are available as accessories for the devices: CDC A 03, CDC A 08 and IDC A 09.

Activating/deactivating demo mode

The device is supplied from the factory with demo mode activated. The various functions of the device are displayed graphically as animations in the display during demo mode. You can also deactivate demo mode.

- Press and hold down the **MENU** button  for longer than four seconds to activate/deactivate demo mode.

Theft protection

Detachable control panel

The device is equipped with a detachable control panel (flip-release panel) as a way of protecting your equipment against theft. The device is worthless to a thief without this control panel.

Protect your device against theft by taking the control panel with you whenever you leave your vehicle. Do not leave the control panel inside your vehicle - not even in a hiding place.

The control panel has been designed to be easy to use.

Notes:

- Never drop the control panel.
- Never expose the control panel to direct sunlight or other heat sources.
- Store the control panel in the supplied case.
- Avoid direct contact with the control panel's electrical contacts. If necessary, clean the contacts with a lint-free cloth and some alcohol.

Detaching the control panel

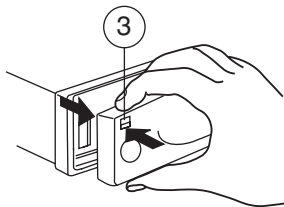

- Press the **LV** button (3).

The locking mechanism of the control panel is unlocked.

- Pull the control panel straight out of the device and to the left.

Notes:

- After removing the control panel from the device, the device switches off.
- All the current settings are saved.
- Any CD already inserted in the device remains there.

Attaching the control panel

- Push the control panel into the guides of the device from the left to the right.
- Carefully push the left side of the control panel into the device until it clicks into place.

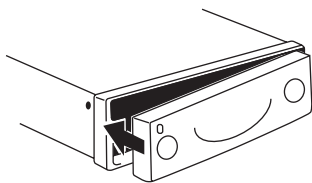

Note:

When attaching the control panel, make sure you do not push on the display.

Switching on/off

There are various ways of switching the device on/off:

Switching on/off using button (1)

- To switch on the device, press button (1).

The device switches on.

- To switch off the device, press and hold down button (1) for longer than two seconds.

The device is switched off.

Switching on/off using the vehicle ignition

The device will switch on/off simultaneously with the ignition if the device is correctly connected to the vehicle's ignition and you did not switch the device off by pressing button (1).

The device can also be switched on with switched-off ignition.

- Press the button (1).

Note:

To protect the vehicle battery, the device will switch off automatically after one hour if the ignition is off.

Volume

You can adjust the volume in steps from 0 (off) to 50 (maximum).

To increase the volume,

- turn the volume control (2) clockwise.

To decrease the volume,

- turn the volume control (2) counter-clockwise.

Setting the power-on volume

You can set the default volume level at which the device plays when it is switched on.

- Press the **MENU** button (9).
- Press the softkey (5) with the display label "VOLUME".
- Press the softkey (5) with the display label "ON VOL".
- Adjust the desired volume with volume control (2).
- Press the **OK** joystick (8) or the **MENU** button (9) to exit the menu.

The settings are saved.

Note:

The volume played last before switch-off can also be selected as the power-on volume. For this purpose, press the softkey with the display label "LAST VOL" in the Volume menu



Risk of injury!

If the power-on volume is set to maximum, the volume level can be very high when the device is switched on!

If the volume was set to maximum before the device was switched off and the power-on volume is set to "LAST VOL", the volume level can be very high when the device is switched on again!

Severe damage to your hearing can be caused in both cases!

Mute

You can decrease the volume abruptly.

- Briefly press button (1).

The display shows "MUTE".

Cancelling mute

- Briefly press button (1) again

or

- turn the volume control (2).

Telephone audio

If your car sound system is connected with a cellphone, "picking" up the phone automatically mutes the car sound system and the call is layed back via the loudspeakers of the car sound system. For this purpose, the cell phone must be connected to the device as described in the installation instructions.

If the sound system receives a traffic announcement during a telephone call, you will only be able to hear the traffic announcement after the call is finished (in so far as the traffic announcement is still being broadcast).

If the sound system receives a call during a traffic announcement, the playback of the traffic announcement is interrupted and the call is answered.

You can adjust the volume with which the telephone calls are answered.

- Press the **MENU** button (9).
- Press the softkey (5) with the display label "VOLUME".
- Press the softkey (5) with the display label "PHONE" to set the volume.
- Adjust the desired volume with volume control (2).
- Press the **OK** joystick (8) or the **MENU** button (9) to exit the menu.

The settings are saved.

Note:

During the phone call, you can always change the volume by means of the volume control (2).

Navigation audio

Instead of a second external audio source ("AUX2", see "External audio sources"), you can also connect a navigation system.

If your car sound system is connected to navigation system, the voice output of the navigation is "mixed" in with the current audio source and played back using the loudspeakers of the car sound system.

For this purpose, the navigation system be connected to the car sound system as described in the installation instructions and switched on in the menu.

You can find out from your Blaupunkt dealer which navigation systems can be used with your car sound system.

Activating the navigation audio

You can connect either a second external audio source or a navigation system to this device. For this purpose, you must define in the menu which device has been connected.

- Press the **MENU** button (9).
- Press the softkey (5) with the display label "AUX".

The AUX menu is displayed.

- If you connected a navigation system, press the softkey (5) with the display label "NAV/AUX2" repeatedly until the setting "NAVIGATION ON" appears.
- Press the **OK** joystick (8) or the **MENU** button (9) to exit the menu.

The settings are saved.

Adjusting the navigation minimum volume

You can set the volume level at which the navigation announcements are mixed in.

Note:

Adjust the volume at the navigation system to the maximum value. If interferences occur during playback, slightly reduce the volume at the navigation system.

- Press the **MENU** button (9).
- Press the softkey (5) with the display label "VOLUME".
- Press the softkey (5) with the display label "NAVI DIFF" to set the volume.
- Adjust the desired volume with volume control (2).
- Press the **OK** joystick (8) or the **MENU** button (9) to exit the menu.

The settings are saved.

Note:

During the voice output, you can always change the volume by means of the volume control (2). This setting applies to the current voice output and is not stored.

Sound and volume relationship

Note:

You can perform separate adjustments for bass and treble for each audio source.

Adjusting the bass

- Press the **AUDIO** button (10).
"AUDIO MENU" appears on the display.
- Press the softkey (5) with the display label "BASS".
- Move the joystick (8) up or right to increase the bass or down or left to decrease the bass.

When you have finished making your changes,

- press the **OK** joystick (8) or the **AUDIO** button (10).

Adjusting the treble

- Press the **AUDIO** button (10).
"AUDIO MENU" appears on the display.
- Press the softkey (5) with the display label "TREBLE".
- Move the joystick (8) up or right to increase the treble or down or left to decrease the treble.

When you have finished making your changes,

- press the **OK** joystick (8) or the **AUDIO** button (10).

Setting the left/right volume ratio (balance)

➤ To adjust the balance, press the **AUDIO** button (10).

"AUDIO MENU" appears on the display.

➤ Press the softkey (5) with the display label "BALANCE".

➤ Move the joystick (8) up or right or down or left to adjust the right/left volume distribution.

When you have finished making your changes,

➤ press the **OK** joystick (8) or the **AUDIO** button (10).

Adjusting the front/rear volume ratio (fader)

➤ To adjust the fader, press the **AUDIO** button (10).

"AUDIO MENU" appears on the display.

➤ Press the softkey (5) with the display label "FADER".

➤ Move the joystick (8) up or right or down or left to adjust the front/rear volume distribution.

When you have finished making your changes,

➤ press the **OK** joystick (8) or the **AUDIO** button (10).

X-BASS

X-Bass allows for boosting the bass at low volume levels. The X-Bass boost (Level) can be set in steps ranging from 0 to 6 for **one** of the following frequencies: 32 Hz, 40 Hz, 50 Hz, 63 Hz or 80 Hz. Selecting 0 deactivates the X-Bass function.

➤ Press the **AUDIO** button (10).

"AUDIO MENU" appears on the display.

➤ Press the softkey (5) with the display label "X-BASS".

➤ Move the joystick (8) to the left or the right to select the frequency to be increased.

➤ Move the joystick (8) up to increase the X-BASS or down to decrease the X-BASS.

When you have finished making your changes,

➤ press the **OK** joystick (8) or the **AUDIO** button (10).

Display

You can adjust the display to suit the installation position in your vehicle and to suit your needs.

Adjusting the viewing angle

- Press the **MENU** button (9).
- Press the softkey (5) with the display label "DISPLAY".
- Press the softkey (5) with the display label "ANGLE".
- Move the joystick (8) up or right or down or left to adjust the viewing angle.
- Press the **OK** joystick (8) or the **MENU** button (9) to exit the menu.

The settings are saved.

Adjusting the display brightness

If your car sound system is connected as described in the installation instructions, the display brightness switches with the headlights. The display brightness can be adjusted separately for day and night in increments from 1-16.

Display brightness

- Press the **MENU** button (9).
- Press the softkey (5) with the display label "DISPLAY".
- Press the softkey (5) with the display label "BRIGHT".

The top line of the display shows "DAY" and "NIGHT" together with the current values.

- Move the flashing selection mark behind "DAY" or "NIGHT" by moving the joystick (8) to the left or the right.

- Set the desired value by moving the joystick (8) up or down.
- Press the **OK** joystick (8) or the **MENU** button (9) to exit the menu.

The settings are saved.

Setting the button illumination colour

You can set the colour in which the buttons of the device are illuminated.

16 colours are available.

- Press the **MENU** button (9).
- Press the softkey (5) with the display label "DISPLAY".
- Press the softkey (5) with the display label "KEYCOLOR".
- Move the joystick (8) up or right or down or left to adjust a colour. Every movement of the joystick selects a different colour.
- Press the **OK** joystick (8) or the **MENU** button (9) to exit the menu.

The settings are saved.

Setting the display illumination colour

When setting the display illumination, you can choose one of four preset colours or you can mix a colour yourself from the RGB spectrum (red-green-blue) or you can select a colour during a colour scan.

Selecting a preset colour

Four different colours are already stored in the device. "Ocean" (blue), "Amber", "Sunset" (red-orange) and "Nature" (green) are available. Select a colour that best suits your vehicle interior.

- Press the **MENU** button (9).
- Press the softkey (5) with the display label "DISPLAY".
- Press the softkey (5) with the display label "COLOR".
- Press the softkey (5) with the display label of the desired colour.
- Press the **OK** joystick (8) or the **MENU** button (9) to exit the menu.

The settings are saved.

Mixing a colour for the display illumination

To customise the display illumination to suit your taste, you can mix a colour yourself using the three primary colours red, green and blue.

- Press the **MENU** button (9).
- Press the softkey (5) with the display label "DISPLAY".
- Press the softkey (5) with the display label "COLOR".
- Press the softkey (5) with the display label "USER".

➤ The following menu allows you to define the components of the three colours red, green and blue. For this purpose, repeatedly press the corresponding softkey (5) until the colour displayed corresponds to your taste.

- Press the **OK** joystick (8) or the **MENU** button (9) to exit the menu.

The settings are saved.

Selecting a display illumination colour during a colour scan

- Press the **MENU** button (9).
- Press the softkey (5) with the display label "DISPLAY".
- Press the softkey (5) with the display label "COLOR".
- Press the softkey (5) with the display label "COL-SCAN".

The device starts changing the display illumination colour.

- If you want to select one of the colours, press the softkey (5) with the display label "SAVE".
- If you want to return to the previous menu without changing the colour, press the softkey with the display label "BREAK".
- Press the **OK** joystick (8) or the **MENU** button (9) to exit the menu.

The settings are saved.

Adjusting the spectrum analyser

The spectrum analyser on your display shows the output level of the car sound system. If the spectrum analyser is switched on, it is automatically displayed if you do not press a key for a while during the playback of an audio source.

You can also deactivate the spectrum analyser.

Switching the spectrum analyser on/off

- Press the **MENU** button (9).
- Press the softkey (5) with the display label "DISPLAY".
- Press the softkey (5) with the display label "SPECTRUM" repeatedly until the desired setting "SPECTRUM OFF" or "SPECTRUM ON" appears in the top line of the display.
- Press the **OK** joystick (8) or the **MENU** button (9) to exit the menu.

The settings are saved.

Inverting display contents

You can invert the display representation.

- Press the **MENU** button (9).
- Press the softkey (5) with the display label "DISPLAY".
- Press the softkey (5) with the display label "INVERT".
- Press the **OK** joystick (8) or the **MENU** button (9) to exit the menu.

The settings are saved.

Radio mode

This device is equipped with an RDS radio receiver. Many of the receivable FM stations broadcast a signal that not only carries the programme but also additional information such as the station name and programme type (PTY).

The station name appears on the display as soon as the tuner receives it. The programme type can be displayed upon request. For further information, please read the section entitled "Programme type (PTY)".

Adjusting the tuner

To ensure proper functioning of the tuner, the device must be set for the region in which you are located. You can select between Europe and America (USA). The tuner is factory-set to the region in which it was sold. If you experience problems with your radio reception, please check this setting.

- Press the **MENU** button (9).
- Press the softkey (5) with the display label "TUNER".
- Press the softkey (5) with the display label for the desired region, "AREA EUR" or "AREA USA".
- Press the **OK** joystick (8) or the **MENU** button (9) to exit the menu.

The settings are saved.

Setting the number of antennas

This device is equipped with two RDS radio receivers (TwinCeiver). You can connect one or two antennas to the device. If two antennas are used (strongly recommended, the second antenna is part of the scope of delivery) a directional reception of the station being received is possible in DDA radio mode. In most cases, the directional reception significantly improves the reception quality.

Note:

To ensure proper functioning of the tuner, the main antenna must be connected to the bottom antenna socket.

To set the number of antennas,

- press the **MENU** button (9).
- Press the softkey (5) with the display label "TUNER".
- Press the softkey (5) with the display label "ONE ANTE" if one antenna is connected to the device.

Or

- Press the softkey (5) with the display label "TWO ANTE" if two antennas are connected to the device.
- Press the **OK** joystick (8) or the **MENU** button (9) to exit the menu.

The settings are saved.

Switching to radio mode

If the device is in the operating modes CD/MP3 or CD changer/Compact Drive,

➡ press the **TUNER** button (13).

The basic radio menu for selecting the station is displayed. The functions of the radio mode are controlled via the radio function menu. You reach the radio function menu by pressing the **TUNER** button (13) again in radio mode.

Selecting static/dynamic radio mode (FM only)

You can select from two modes for FM radio mode:

Static radio mode ("PRESETS" and "DDA")

In the static radio mode, four memory banks (FM1, FM2, FM3 and FMT) are available in FM mode. You can store six stations in each of these memory banks. The receiving unit automatically adjusts the best receivable frequency of the station for each of the stored stations.

PRE mode (static)

If you connected only **one** antenna to the device and set it up in the setup menu (see "Setting the number of antennas"), the device plays back the configured station with one tuner and searches for the best frequency of the adjusted station with the second tuner (with activated RDS function).

Digital Directional Antenna mode – DDA (static)

If you connected **two** antennas to the device and set them up in the setup menu (see "Setting the number of antennas"), the adjusted station is received with both antennas in DDA radio mode. In the process, the TwinCeiver continuously analyses the signals of both antennas and calculates a "clean signal" from them to reduce reception interferences. This process developed by Blaupunkt corresponds to a directional aerial with respect to its mode of operation. Particularly in areas with reception interferences due to reflections from buildings, mountains, etc., the reception quality is significantly improved. In exceptional cases, e.g. reception of two different stations on the same frequency, it may lead to an undesirable reception behaviour. In such a case, you should select the dynamic radio mode (see "Selecting the radio mode" below).

Dynamic radio mode

In dynamic radio mode, five levels (DL1 - DL5) are available. While the adjusted station is being played back, the second reception searches for receivable stations in the background and displays all receivable stations with short name next to the softkeys on the memory bank. The station are constantly updated so that you can always access receivable stations.

Selecting the radio mode

To select between the modes static and dynamic,

➤ press the **TUNER** button (13) in radio mode.

The display shows the radio function menu.

➤ Press the **NEXT** button (4).

The display shows the second page of the radio function menu.

➤ Press the softkey (5) with the display label "TUNER 2".

➤ Press the softkey (5) with the display label "DYN LIST" for the dynamic radio mode.

➤ Press the softkey (5) with the display label "DDA" or "PRESETS" for one of the static radio modes.

➤ Press the **OK** joystick (8) or the **MENU** button (9) to exit the menu.

The settings are saved.

Convenient RDS functions (AF, REG)

The convenient RDS functions AF (Alternative Frequency) and REG (Regional) extend your radio's range of functions (in FM mode only).

- AF: If the RDS function is activated, the radio automatically tunes into the best receivable frequency for the station that is currently set.
- REG: At certain times, some radio stations divide their programme into regional programmes providing different content. You can use the REG function to prevent the car radio from switch-

ing to alternative frequencies that are transmitting a different regional programme content.

Note:

REG must be activated/deactivated separately in the radio functions menu.

Switching the RDS function on/off

If you want to use the convenient RDS functions (AF and REG),

➤ press the **TUNER** button (13) in radio mode.

The display shows the radio function menu.

➤ Press the softkey (5) with the display label "RDS" repeatedly until the desired setting "RDS ON" or "RDS OFF" appears.

To change back to the basic radio menu,

➤ press the **TUNER** button (13) or the **OK** joystick (8).

The settings are saved.

Switching REG on/off

To use the convenient RDS function REG,

➤ press the **TUNER** button (13) in radio mode.

➤ Press the **NEXT** button (4) to display the second page of the radio function menu.

The display shows the radio function menu.

➤ Press the softkey (5) with the display label "REGIONAL" repeatedly until "REGIONAL ON" or "REGIONAL OFF" appears.

- press the **TUNER** button (13) or the **OK** joystick (8).

The settings are saved.

Selecting the waveband/memory bank

This device can receive programmes broadcast over the FM frequency range as well as the MW, LW and SW (AM) wavebands. Four memory banks are available for the FM waveband and one memory bank each for the wavebands MW, LW and SW.

In dynamic radio mode, up to five levels are available.

Six stations can be stored in each memory bank.

Note:

If your device is set to the region USA, you can select between the wavebands FM and AM. In addition, the memory banks AM1, AM2, and AMT are available for the AM waveband.

Selecting a waveband

To select an FM, MW, LW or SW waveband,

- press the **TUNER** button (13) in radio mode.

The display shows the radio function menu.

- Press the softkey (5) with the display label "BAND".
- Press the softkey (5) with the display label "FM" for the FM waveband.
- Press the softkey (5) with the display label "MW" for the MW waveband.
- Press the softkey (5) with the display label "LW" for the LW waveband.

- Press the softkey (5) with the display label "SW" for the SW waveband.

The basic radio menu of the selected waveband is displayed.

Selecting the FM memory bank

To switch between the FM memory banks FM1, FM2, FM3 and FMT,

- press the **NEXT** button (4) repeatedly until the display shows the desired memory bank.

The memory banks are called in sequence from FM1 to FM2, FM3 and FMT.

Note:

If your device is set to the region USA and you selected the AM waveband, you can use the **NEXT** button (4) to select from the AM memory banks AM1, AM2 and AMT.

Tuning into a station

There are various ways of tuning into a station.

Automatic station seek tuning

➔ Move the joystick (8) up or down.

The radio tunes into the next receivable station.

Tuning into stations manually

You can also tune into stations manually.

Note:

You can only tune into stations manually if the RDS function is deactivated.

➔ Move the joystick (8) to the left or the right.

Browsing through broadcasting networks (FM only)

If a radio station provides several programmes, you have the option of browsing through its so-called "broadcasting network".

Note:

The convenient RDS function must be activated before you can use this feature. When using this feature, you will only be able to switch to stations that you have received once before already.

➔ Move the joystick (8) to the left or the right.

Setting the sensitivity of station seek tuning

You can choose whether the radio should only tune into stations providing good reception or whether it can also tune into those with a weak reception.

➔ press the **TUNER** button (13) in radio mode.

The display shows the radio function menu.

➔ Press the **NEXT** button (4).

Note:

If you call up the radio function menu in the MW or LW radio mode, the softkey with the display label "SENS" is on the first page.

➔ Press the softkey (5) with the display label "SENS".

➔ Press the softkey (5) with the display label "FM" or "AM" to set the sensitivity for "FM" or "AM".

➔ Move the joystick (8) up or right or down or left to set the sensitivity.

You can adjust the sensitivity in increments from 1 to 6. "Sensitivity 1" is the lowest, "Sensitivity 6" the highest sensitivity for very remote stations.

➔ Press the **OK** joystick (8) or the **MENU** button (9) to exit the menu.

The settings are saved.

Scanning receivable stations (SCAN)

You can use the scan function to play all the receivable stations briefly. You can set the scanning time in the menu to between 5 and 30 seconds.

Starting SCAN

- Press and hold down the **OK** joystick (8) for longer than two seconds.

Scanning begins. "SCAN" appears briefly on the display followed by a flashing display of the current station name or the frequency of the station.

Cancelling SCAN and continuing listening to a station

- Press the **OK** joystick (8).

Scanning stops and the radio continues playing the station that it tuned into last.

Setting the scanning time

- Press the **MENU** button (9).
- Press the softkey (5) with the display label "VARIOUS".
- Press the softkey (5) with the display label "SCANTIME".
- Move the joystick (8) up or right or down or left to set the scan time.
- Press the **OK** joystick (8) or the **MENU** button (9) to exit the menu.

The settings are saved.

Note:

The defined scanning time is also applied by the system to scanning carried out in CD/MP3 and CD-changer mode.

Storing stations

Storing stations manually

- Select the desired FM memory bank (FM1, FM2, FM3, FMT) or one of the wavebands (MW, LW or SW).
- Tune into the desired station as described under "Tuning into a station".
- Press and hold down one of the six softkeys for longer than two seconds to which you want to assign the station.

Storing stations automatically (Travelstore)

You can automatically store the six stations offering the strongest reception in the region (FM only). The stations are stored in the FMT memory bank.

Notes:

- If your device is set to the region USA, you can also start the Travelstore in the AM radio mode. The stations are then stored on the AMT level.
- Any stations that were previously stored in this memory bank are deleted in the process.

Starting the Travelstore function

- Press the **TUNER** button (13) in radio mode.

The display shows the radio function menu.

- Press the softkey (5) with the display label "T-STORE".

The storing procedure begins. "TRAVEL STORE" appears on the display. After the process has completed, the radio will play the station that is stored in memory location one of the FMT (or AMT) memory bank.

Listening to stored stations

- Select the memory bank or waveband.
- Press the softkey (5) with the display label of the station name or the frequency of the desired station.

Programme type (PTY)

Besides transmitting the station name, some FM stations also provide information on the type of programme that they are broadcasting. Your car radio can receive and display this information.

For example, the programme types can be:

CULTURE	TRAVEL	JAZZ
SPORT	NEWS	POP
ROCK	CLASSICS	

You can use the PTY function to select stations of a particular programme type.

PTY-EON

If you specify the programme type and start seek tuning, the radio will switch from the current station to a station of the selected programme type.

Notes:

- If the tuner does not find a station that corresponds to the selected programme type, you will hear a beep and "NO PTY" appears briefly in the display. The radio will then retune to the station that it received last.

- If the tuned radio station or another station on the broadcasting network broadcasts your selected programme type at a later point in time, the radio will automatically switch from the currently tuned station or from CD/MP3 mode or CD-changer mode to the station whose programme type matches the one you selected.

Activating PTY

To use the PTY function,

- press the **TUNER** button (13) in radio mode.

The display shows the radio function menu.

- Press the **NEXT** button (4).
- Press the softkey (5) with the display label "PROG TYP".

If PTY is activated, the display shows the current programme type. PTY is illuminated on the display. The programme types are shown next to the softkeys (5).

Deactivating PTY

To deactivate the PTY function,

- press the softkey (5) with the display label "PTY OFF" while the programme types are displayed.

Selecting a programme type and starting seek tuning

The PTY menu has several pages on which the known programme types are displayed. To scroll through the individual pages of the PTY menu,

- press the **NEXT** button (4) until the desired programme type is displayed next to one of the softkeys.
- Press the softkey (5) with the desired programme type.
- Move the joystick (8) up or right or down or left to start the seek tuning.

The radio will then tune into the next receivable station that it finds that corresponds to your selected programme type.

If the tuner does not find a station that corresponds to the selected programme type, you will hear a beep and "NO PTY" appears briefly in the display. The radio will then retune to the station that it received last.

If you want to return to the display of the programme types,

- call up the second page of the radio function menu again and press the softkey (5) with the display label "PROG TYP".

Optimising radio reception

Treble reduction feature during interference (HiCut)

The HiCut function causes a reduction of the interferences during poor radio reception. If interference occurs, the system automatically reduces the treble thus reducing the interference level.

Adjusting HiCut

- press the **TUNER** button (13) in radio mode.

The display shows the first page of the radio function menu.

- Press the **NEXT** button (4).
- Press the softkey (5) with the display label "HIGH CUT" repeatedly until the desired setting appears.

"HICUT 0" means that no automatic reduction of the treble and interference level will be made; "HICUT 2" means that a maximum reduction will be made.

- Press the **OK** joystick (8) or the **TUNER** button (13) to exit the menu.

The settings are saved.

Activating/deactivating the radio text display

Some stations use the RDS signal to broadcast scrolling texts known as radio texts. You can allow radio texts to be displayed or you can block them.

- Press the **TUNER** button (13) in radio mode.

The display shows the radio function menu.

- Press the softkey (5) with the display label "R-TEXT" repeatedly until the desired setting "RADIO TEXT ON" or "RADIO TEXT OFF" appears.
- press the **TUNER** button (13) or the **OK** joystick (8).

The settings are saved.

TIM – Traffic Information Memory

The device features a digital voice memory which allows for automatically recording up to four traffic announcements. The maximum length for recorded messages is four minutes.

If the TIM function is activated, all traffic announcements that are received two hours after the last switch-off of the device are recorded. In addition, you can also set two fixed times (Timer). All traffic announcements that are broadcast 30 minutes before and 90 minutes after the specified time on the selected traffic announcement program are recorded. This function is particularly useful if you are using your car at fixed times.

If the last message is older than six hours, all messages are deleted.

If a new traffic announcement arrives during the TIM playback, the playback is interrupted and the new message is recorded.



Risk of damage to the motorised antenna in a car wash. An automatic motorised antenna remains extended if TIM is activated and you switch off the device. In a car wash, the extended motorised antenna may cause damages. For further information, please read the section entitled "Switching TIM off".

Switching TIM on/off

If the car sound system is switched on, you can switch the TIM functions on or off.

- In radio mode, hold the **TUNER** button (13) pressed for longer than two seconds.

The TIMPLAY menu is displayed.

If traffic announcements were recorded, the last message is played. The most current message has the number "TIM1". The station name/frequency appears in the top line of the display and the time of the recording in the bottom line.

"TIM" and the number of the message appear next to the top two softkeys on both sides of the display.

If no messages are recorded, "NO TIM" briefly appears on the display.

Switching TIM off

If you want to switch TIM off,

- In radio mode, hold the **TUNER** button (13) pressed for longer than two seconds.

The TIMPLAY menu is displayed.

- Press the **NEXT** button (4).

The TIMSET menu again.

- Press the softkey (5) with the display label "TIM ON" repeatedly until "TIM RECORD OFF" appears on the display.

- press the **TUNER** button (13) or the **OK** joystick (8).

The settings are saved.

Note:

If you do not switch on the device for more than 72 hours, the TIM function is automatically switched off.

Switching TIM on

If you want to switch TIM on again,

- in radio mode, hold the **TUNER** button (13) pressed for longer than two seconds.

The TIMPLAY menu is displayed.

- Press the **NEXT** button (4).

The TIMSET menu again.

- Press the softkey (5) with the display label "TIM ON" repeatedly until "TIM RECORD ON" appears on the display.

- Press the **TUNER** button (13) or the **OK** joystick (8).

The settings are saved.

Note:

After switching off the device with the vehicle ignition or the button (1), the current status "TIM ON" or "TIM OFF" briefly appears on the display.

Playing stored traffic announcements

To play the stored traffic announcements,

- in radio mode, hold the **TUNER** button (13) pressed for longer than two seconds.

The TIMPLAY menu is displayed.

If traffic announcements were recorded, the last message is played. The most current message has the number "TIM1". The station name/frequency appears in the top line of the display and the time of the recording below it. After the first message, all additional messages are played in ascending order.

If no messages are recorded, "NO TIM AVAILABLE" briefly appears on the display.

After the last message, the system switches back to the previous operating mode.

If you want to return to the radio mode without first listening to all messages,

- press the **TUNER** button (13) or the **OK** joystick (8).

Selecting the TIM message

"TIM" and the number of the message appear next to the top two softkeys on both sides of the display.

If you want to listen to one of the displayed messages without playing the other messages:

- Press the softkey (5) with the corresponding display label "TIM1", "TIM2", "TIM3" or "TIM4".

Recording traffic announcements

If the device is switched on, traffic announcements are automatically recorded if a traffic information station is received and the priority for traffic announcements is switched on.

If you are listening to a station that does not broadcast traffic information and you switch off the device while the TIM function is switched on, the device automatically searches for a traffic information station.

Setting the timer

If TIM is switched off, the traffic announcements of a set traffic information station are recorded for 2 hours after switching off the device. In addition, you can set two timers that record all traffic announcements 30 minutes before and 90 minutes after the adjusted time. The timer is based on the system time. How to set the system time is described in the chapter "Clock - Time".

To adjust one of the timers,

➤ in radio mode, hold the **TUNER** button (13) pressed for longer than two seconds.

The TIMPLAY menu is displayed.

➤ Press the **NEXT** button (4).

The TIMSET menu again.

➤ Press the softkey (5) with the display label "TIMER1" for the first timer or "TIMER2" for the second timer.

The display shows the adjusted time, the hours are flashing.

➤ Move the joystick (8) up or down and adjust the hour.

➤ Move the joystick (8) right and change the entry position.

The minutes flash.

➤ Move the joystick (8) up or down and adjust the minutes.

To save the settings,

➤ press the **TUNER** button (13) or the **OK** joystick (8).

The settings are saved.



During the TIM readiness, a connected motorised antenna is extended.

Note:

It is absolutely necessary to switch off TIM before entering a car wash. For instructions, please read the section "Switching TIM off" in this chapter.

Selecting timers

After you have set the timers, you can select between the two timers. The timer which you adjusted last is always active.

To select a timer,

➤ in radio mode, hold the **TUNER** button (13) pressed for longer than two seconds.

The TIM PLAY menu is displayed.

➤ Press the **NEXT** button (4).

The TIMSET menu again.

➤ Press the softkey (5) with the display label "TIMER1" to select the first timer or "TIMER2" to select the second timer.

➤ press the **TUNER** button (13) or the **OK** joystick (8).

The settings are saved.

Traffic information

Your device is equipped with an RDS-EON receiver. EON (**E**nanced **O**ther **N**etwork) is the transmission of station information within a broadcasting network.

Whenever a traffic announcement (TA) is broadcast, the system switches automatically from a station that does not provide traffic reports to the appropriate traffic information station within the broadcasting network that does.

Once the traffic report has been played, the system will switch back to the programme that you were listening to before.

Switching traffic information priority on/off

➤ Press the **TUNER** button (13) in radio mode.

The display shows the radio function menu.

➤ Press the softkey (5) with the display label "TRAFFIC" repeatedly until the desired setting "TRAFFIC INFO ON" or "TRAFFIC INFO OFF" appears.

Note:

The TA menu is displayed during a traffic announcement.

To interrupt the current traffic announcement,

➤ press the softkey (5) with the display label "TA EXIT".

If you want to switch off the priority for traffic announcements in general,

➤ press the softkey (5) with the display label "TA OFF".

Notes:

You will hear a warning beep:

- If you leave the reception area of a traffic information station that you are currently listening to.
- If you leave the reception area of a traffic information station that the system is tuned into while listening to a CD, and the subsequent automatic seek tuning cannot find a new traffic information station.
- If you retune the radio from a traffic information station to a station that does not broadcast traffic information.

If you hear the warning beep, you can either switch off traffic information priority or tune into a station that broadcasts traffic information.

Setting the volume for traffic announcements

➤ Press the **MENU** button (9).

➤ Press the softkey (5) with the display label "VOLUME".

➤ Press the softkey (5) with the display label "TRAFFIC".

➤ Adjust the desired volume with volume control (2).

➤ Press the **OK** joystick (8) or the **MENU** button (9) to exit the menu.

CD mode

You can use this device to play standard audio CDs with a diameter of 12 cm.

CD-Rs and CD-RWs ("self-burned" CDs) can usually be played. Due to the varying quality of CD blanks, however, Blaupunkt cannot guarantee a faultless function.

To ensure proper functioning, use only CDs with the Compact-Disc logo. Copy-protected CDs can cause playback problems. Blaupunkt cannot guarantee the proper functioning of copy-protected CDs!



Risk of severe damage to the CD drive!

CD singles with a diameter of 8 cm and noncircular contoured CDs (shape CDs) must not be used.

We accept no responsibility for any damage to the CD drive that may occur as a result of the use of unsuitable CDs.

Starting CD mode, inserting a CD

If there is no CD inserted in the device,

- press the  button (7).

The control panel opens out towards you.

- Push the CD into the CD tray with the printed side facing up.

The drive draws in the CD.

You must not hinder or assist the drive as it draws in the CD.

The control panel automatically closes.

The CD menu is displayed and the CD playback starts.

If a CD is already inserted in the device,

- press the **SOURCE** button (12) repeatedly until CD mode is displayed.

The CD menu is displayed, the playback starts at the point where it was interrupted.

Ejecting a CD

- press the  button (7).

The control panel opens to the front, the CD is ejected.

- Carefully remove the CD.

- Press the  button (7).

The control panel closes.

Selecting tracks

- Move the joystick (8) in one direction (up and right for the next or down and left for the previous track) until the number of the desired track appears on the display.

Pressing the joystick (8) once down or left restarts the current track.

Fast searching (audible)

To fast search backwards or forwards,

- hold the joystick (8) pressed in one direction (up and right for forwards or down and left for backwards) until fast searching starts.

Random track play (MIX)

- Press the softkey (5) with the display label "MIX".

"MIX CD" briefly appears on the display. The next track being played is randomly selected.

Cancelling MIX

- Press the softkey (5) with the display label "MIX" again.

"MIX OFF" briefly appears on the display.

Repeating tracks (REPEAT)

- Press the softkey (5) with the display label "REPEAT".

"REPEAT TRACK" briefly appears on the display. The track is repeated continuously until you deactivate REPEAT.

Cancelling Repeat

- Press the softkey (5) with the display label "REPEAT" again.

"REPEAT OFF" briefly appears on the display. Normal playback is then resumed.

Scanning tracks (SCAN)

You can scan (briefly play) all the tracks on the CD.

- Press and hold down the **OK** joystick (8) for longer than two seconds.

The next titles of the CD are scanned in ascending order.

Note:

You can set the scanning time. For further information, please read the section entitled "Setting the scanning time" in the "Radio mode" chapter.

Cancelling Scan and continuing listening to a track

To end the scanning process,

- press the **OK** joystick (8).

The currently scanned track will then continue to be played normally.

Displaying CD text

Some CDs include CD text. The CD text might contain the names of the artist, album and tracks.

You can allow the CD text to be displayed as scrolling text in the bottom line every time you switch to another track.

If the inserted CD does not contain CD text, "NO TEXT" is briefly shown on the display with CD text switched on.

Switching CD text on/off

- Press the softkey (5) with the display label "TEXT" repeatedly until "CD TEXT ON" or "CD TEXT OFF" appears.

Adjusting the scrolling text

You can allow the CD text to be displayed as scrolling text in the bottom line of the display.

Switching CD scrolling text on/off

- Press the softkey **5** with the display label "SCROLL" repeatedly until "SCROLL ON" (scrolling text is switched on) or "SCROLL OFF" appears.

Traffic announcements in CD mode

- Press the softkey **5** with the display label "TRAFFIC" repeatedly until the desired setting "TRAFFIC INFO ON" or "TRAFFIC INFO OFF" appears.

MP3 mode

You can play MP3 files stored on an MMC/SD (Multimedia Card/Secure Digital) or on a CD-R/CD-RW. You can write data onto the MMC/SD that you want to use with the Bremen MP76 with the help of a standard MMC/SD read and write device and your PC.

Preparing an MP3 CD

The various combinations of CD burners, CD burning software and CD blanks may lead to problems arising with the device's ability to play certain CDs. If problems occur with your own burned CDs, you should try another brand of CD blank or choose another colour of CD blank.

The format of the CD must be ISO 9660 Level 1 or Level 2 or Joliet. Other formats cannot be played reliably.

Avoid multi-sessions. If you write more than one session onto the CD, only the first session is recognised.

You can create a maximum of 127 directories on a CD. You can use this device to access each of these directories.

Each directory can contain up to 254 individual titles (tracks) and subdirectories which can be selected individually. The directory depth may contain up to 8 levels.

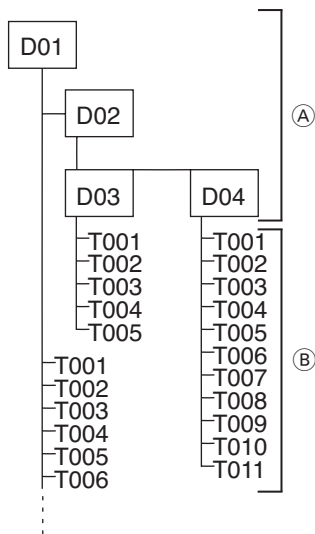

- Ⓐ Directories
 Ⓑ Tracks · Files

You can name each directory using a PC. The device is capable of displaying the directory name. Name the directories and tracks using your CD burner software. The software's instruction manual will provide details on how to do this.

Note:

When naming directories and tracks, you should avoid using accents and special characters.

If you like your files to be in the correct order, you should use burner software that places files in alphanumerical order. If your software does not provide this feature you also have the option of sorting the files manually. For this purpose, you must enter a number in front of each file name, e.g. "001", "002", etc. The leading zeros must also be entered.

MP3 tracks can contain additional information such as the artist, album and track names (ID3 tags). This device can display ID3 tags (version 1).

This device can only play MP3 files that have the ".MP3" file extension.

Notes:

To ensure uninterrupted playback:

- Do not try changing the file extension to ".MP3" of any files other than MP3 files and then attempt to play them!
- Do not use mix-mode CDs with non-MP3 data and MP3 tracks.
- Do not use mix-mode CDs containing audio tracks and MP3 tracks.

Inserting/removing MMCs/SDs

The MMC/SD slot ⑭ is located below the detachable control panel, to the right of the contacts. To insert/remove an MMC/SD, you must remove the control panel. For further information, please read the section "Detachable control panel".

Notes:

- Blaupunkt cannot guarantee the correct functioning of all MMC/SD cards available on the market and, for this reason, recommends the use of MMC/SD cards manufactured by "SanDisk" or "Panasonic". The cards maximum size should be 512 MB, since the function cannot always be ensured at larger storage capacities. The cards must be formatted using the FAT16 file system and contain MP3 files.

- In order to optimise the device's access to the data on the MMCs/SDs, you should store no more than 20 directories and a maximum of 200 files on an MMC/SD.

Inserting an MMC/SD

- Detach the control panel.
- Insert the MMC/SD with its labelled side uppermost and its contacts first into the SD/MMC slot (14), until you feel the MMC/SD click into place.
- Attach the control panel again.

Removing an MMC/SD

- Detach the control panel.
 - Carefully push the MMC/SD into the slot (14) until you feel a slight resistance.
- The MMC/SD is now unlatched.
- Carefully pull the MMC/SD out of the slot.
 - Attach the control panel again.

Switching to MMC/SD mode

- Press the Source button (12) repeatedly until the display shows "MMC".
- Playback begins with the first track that the device detects.

Activating the MP3 mode of CD

MP3 mode of CD is activated in the same way as normal CD mode. For insertion, please read the section entitled "Starting CD mode/Inserting a CD" in the chapter "CD mode".

- Press the Source button (12) repeatedly until the display shows "MP3".

Playback begins with the first track that the device detects.

Operation during the MP3 mode

Selecting from directory list

You can display a list of all directories of the inserted CD or MMC/SD and conveniently select from them. The directories are displayed with the names that you used when you burned the CD or created the MMC/SD.

- During the MP3 playback, press the **NEXT** button (4).

The track list of the current directory is displayed.

- Press the joystick (8) left or right to change into the directory list.
- Press the joystick (8) up or down to scroll through the list.
- If you want to select a directory from the list, move the selection mark onto the desired directory and press the **OK** joystick (8).

The list of tracks of the selected directory is displayed.

- Move the selection mark onto the desired track and press the **OK** joystick (8).

- Press the **NEXT** button (4) to redisplay the MP3 main menu.

Selecting a directory with the joystick

To move up or down to another directory,

- Press the joystick (8) repeatedly up or down until the number of the desired directory appears in the first position in the top line of the display.

Note:

The device automatically skips any directories that do not contain MP3 files. For example, if you listen to tracks from directory D01 and select the next directory with the joystick (8), the directory D02, which does not contain any MP3 tracks (see illustration), is skipped and D03 is played. The display then automatically changes from "D02" to "D03".

Selecting tracks

Selecting a track from the track list

You can display a list of all tracks of the current directory and conveniently select a track from it.

- To display the track list, press the **NEXT** button (4).
- Press the joystick (8) up or down to "scroll" through the track list.
- If you want to select a track from the list, move the selection mark onto the desired track and press the **OK** joystick (8).
- Press the **NEXT** button (4) to redisplay the MP3 main menu.

Selecting a track with the joystick

To move up or down to another track in the current directory,

- move the joystick (8) right for the next or left for the previous track until the number of the desired track appears on the display.

Pressing the joystick (8) once left restarts the current track.

Fast searching (audible)

To fast search backwards or forwards,

- press the joystick (8) left or right and hold it pressed until fast searching backwards or forwards begins.

Scanning tracks (SCAN)

You can scan all the tracks on the CD/SD/MMC.

- Press and hold down the **OK** joystick (8) for longer than two seconds.

The next titles of the CD/SD/MMC are scanned in ascending order.

Note:

You can set the scanning time. For further information, please read the section entitled "Setting the scanning time" in the "Radio mode" chapter.

Cancelling Scan and continuing listening to a track

To end the scanning process,

- press the **OK** joystick (8).

The currently scanned track will then continue to be played normally.

Random track play (MIX)

To play the tracks in the current directory in random order,

- press the softkey (5) with the display label "MIX".

"MIX DIR" appears briefly on the display.

To play the tracks contained in all the directories on the inserted MP3-CD/SD/MMC in random order,

- press the softkey (5) with the display label "MIX" again.

"MIX CD/SD/MMC" briefly appears on the display.

Cancelling MIX

To cancel MIX,

- press the softkey (5) with the display label "MIX" repeatedly until "MIX OFF" appears on the display.

Repeating individual tracks or whole directories (REPEAT)

- Press the softkey (5) with the display label "REPEAT".

"REPEAT TRACK" briefly appears on the display.

To repeat the whole directory,

- press the softkey (5) with the display label "REPEAT" again.

"REPEAT DIR" briefly appears on the display.

Cancelling Repeat

To stop the current track or current directory from being repeated,

- press the softkey (5) with the display label "REPEAT" repeatedly until "REPEAT OFF" briefly appears on the display.

Configuring the display

You have different options of displaying the name of the artist, the track and the album (ID3 tag) or the directory and the file. The information from the ID3 tag (album, artist and track) can be displayed only if they were saved while creating the CD or the MP3 file.

The track name is always displayed in the top line of the display during playback. In the process, the track name is displayed once as scrolling text after a track change and subsequently shortened to 16 digits, if necessary, and displayed.

Note:

If the track name from the ID3 tag is not available, the file name is displayed

For the bottom line of the display (info line), you can select from the display of different information.

Selecting information in the info line

In the bottom line of the display (info line), you can select from the display of the different MP3 information, such as track, artist, album or directory number (DIR) or file name.

- Press the softkey **(5)** with the display label "INFO" repeatedly until the desired display appears in the bottom line of the display.

Note:

If the information about artist, track and album is not available as ID3 tag, they cannot be selected.

Display all the information of a file once

To display all the available information of a track as well as the name of the directory and the file once as scrolling text,

- press the softkey **(5)** with the display label "SHOW ALL".

If available, the information is displayed once as scrolling text in the info line. During the display, "SHOW ALL" is flashing.

Adjusting the scrolling text

You can select whether the display you defined under "Selecting information in the info line" should be shown as scrolling text ("SCROLL ON") or once only ("SCROLL OFF").

- Press the softkey **(5)** with the display label "SCROLL" repeatedly until the desired setting appears.

You can scan all the tracks on the CD/SD/MMC.

- Press and hold down the **OK** joystick **(8)** for longer than two seconds.

The next tracks are scanned in ascending order.

Note:

You can set the scanning time. For further information, please read the section entitled "Setting the scanning time" in the "Radio mode" chapter.

CD changer mode (optional)

The CD changers/Compact Drive MP3s that can be used with this device can be found in the chapter "Accessories" in these instructions or obtained from your specialist Blaupunkt dealer.

Note:

Information on handling CDs, inserting CDs and operating the CD changer can be found in the operating instructions supplied with your CD changer.

Switching to CD-changer mode

➤ Press the **SOURCE** button (12) repeatedly until the CD changer menu is displayed.

Playback continues at the point at which it was last interrupted. If the magazine is removed from the CD changer and reinserted, the CD magazine is "scanned" first, the playback starts with the first track of the first CD recognised by the CD changer.

Selecting CDs

To move up or down to another CD,

➤ press the softkey (5) with the display label of the desired CD (CD1 - CD10). If necessary, use the softkey (5) with the display label "NEXT" or "PREVIOUS" to change between the "pages" of the basic CD changer menu

or

➤ press the joystick (8) repeatedly up or down until the number of the desired CD appears on the display.

Selecting tracks

To move down or up to another track on the current CD,

➤ press the joystick (8) repeatedly left or right until the number of the desired track appears on the display.

Pressing the joystick (8) once left restarts the current track.

Fast searching (audible)

To fast search forwards or backwards,

➤ press the joystick (8) left or right and hold it pressed until fast searching backwards or forwards begins.

Scanning tracks (SCAN)

You can scan (briefly play) all the tracks on the CD.

➤ Press and hold down the **OK** joystick (8) for longer than two seconds.

The next titles of the CD are scanned in ascending order.

Note:

You can set the scanning time. For further information, please read the section entitled "Setting the scanning time" in the "Radio mode" chapter.

Cancelling Scan and continuing listening to a track

To end the scanning process,

➤ Press the **OK** joystick (8).

The currently scanned track will then continue to be played normally.

Repeating individual tracks or whole CDs (REPEAT)

To repeat the current track,

- press the **NEXT** button (4).

The display shows the CD changer function menu.

- Press the softkey (5) with the display label "REPEAT".

"REPEAT TRACK" briefly appears on the display.

To repeat the entire CD,

- press the softkey (5) with the display label "REPEAT" again while the CD changer function menu is displayed.

"REPEAT CD" briefly appears on the display.

Cancelling Repeat

To stop the current track or current CD from being repeated,

- press the softkey (5) with the display label "REPEAT" repeatedly while the CD changer function menu is displayed until "REPEAT OFF" briefly appears on the display.

Random track play (MIX)

To play the tracks on the current CD in random order,

- Press the **NEXT** button (4).

The display shows the CD changer function menu.

- Press the softkey (5) with the display label "MIX".

"MIX CD" appears on the display.

To play all of the tracks on all inserted CDs in random order,

- Press the softkey (5) with the display label "MIX" again.

"MIX ALL" appears on the display.

Cancelling MIX

To cancel MIX,

- press the softkey (5) with the display label "MIX" repeatedly until "MIX OFF" briefly appears on the display.

Naming CDs

The car sound system allows you to assign names for up to 99 CDs so that you can recognise them more easily (not with Compact Drive MP3). The names can be a maximum of seven characters long.

"FULL" appears on the display if you try to assign more than 99 names.

Entering/editing CD names

- Listen to the CD to be named.

- Press the **NEXT** button (4).

The display shows the CD changer function menu.

- Press the softkey (5) with the display label "CD NAME".

The current name of the CD is displayed in the top line of the display. If you have not yet named the CD, seven underscores "_" are displayed.

➤ Press the softkey (4) with the display label "EDIT".

You are now in the editing mode. The first text input position flashes.

➤ Move the joystick (8) up or down and select your characters. If you want an empty space, simply select the underscore.

➤ Move the joystick (8) left or right and change the entry position.

➤ To save the name, press the **OK** joystick (8).

Deleting a CD name

➤ Listen to the CD whose name you want to delete.

➤ Press the **NEXT** button (4).

The display shows the CD changer function menu.

➤ Press the softkey (5) with the display label "CD NAME".

➤ Press and hold the softkey (5) with the display label "CLEAR CD" for longer than two seconds.

The CD name is deleted.

Deleting all CD names

➤ Listen to a CD.

➤ Press the **NEXT** button (4).

The display shows the CD changer function menu.

➤ Press the softkey (5) with the display label "CD NAME".

➤ Press and hold the softkey (5) with the display label "CLEAR ALL" for longer than two seconds.

The CD names are deleted.

Clock – time

Setting the time

The time can be set automatically via the RDS signal. If no station supporting this function can be received, you can also set the time manually.

Setting the time automatically

To set the time automatically,

- press the **MENU** button (9).
- Press the softkey (5) with the display label "CLOCK".
- Press the softkey (5) with the display label "AUTOSYNC" repeatedly until "AUTOSYNC ON" appears on the display.

"AUTOSYNC ON" means that the time is automatically set via the RDS signal.

Setting the clock manually

- To set the time, press the **MENU** button (9).
- Press the softkey (5) with the display label "CLOCK".
- Press the softkey (5) with the display label "TIME".

The hours and minutes are displayed in the top line of the display. The hours flash.

- Set the hours by moving the joystick (8) up or down.

To set the minutes,

- press the joystick (8) right.

The minutes flash.

- Set the minutes by moving the joystick (8) up or down.

- Press the **OK** joystick (8) or the **MENU** button (9) to exit the menu.

The settings are saved.

Setting the date

To set the date,

- press the **MENU** button (9).
- Press the softkey (5) with the display label "CLOCK".
- Press the softkey (5) with the display label "DATE".

The top line of the display shows the year (YY), month (MM) and day (DD).

The input position for the year flashes.

- Set the year (e.g. "06" for 2006) by moving the joystick (8) up or down.
- Press the joystick (8) right to move the input position to the month.
- Set the month by moving the joystick (8) up or down.
- Press the joystick (8) right to move the input position to the day.
- Set the day by moving the joystick (8) up or down.
- Press the **OK** joystick (8) or the **MENU** button (9) to exit the menu.

The settings are saved.

Permanent time display

You can show the time of the device on the display with switched-off device and switched on vehicle ignition.

- Press the **MENU** button (9).
- Press the softkey (5) with the display label "CLOCK".
- Press the softkey (5) with the display label "OFFCLOCK".

"SHOW CLOCK" means that the time is displayed, "HIDE CLOCK" means that the time is not displayed.

DSA Max – Digital Sound Adjustment

This device features a means for digital sound calibration (DSA **D**igital **S**ound **A**djustment).

Three self-calibrating user equalizers (EQ1, EQ2 and EQ3) are available for this purpose. Each user equalizer consists of a graphical 27-band equalizer.

Each user equalizer features for channels (front left/right and rear left/right).

The equalizers EQ1 - EQ3 can be adjusted automatically using the supplied calibration microphone.

The values of the graphical equalizer that are determined automatically can also be changed manually.

For additional sound optimisation, you also have access to a dynamic driving noise compensation (DNC), different presettings for music styles (Preset EQ), stage effects and sound effects.

Switching DSA on/off

Switching DSA off

To deactivate the entire equalizer,

- press and hold the **AUDIO** button (10) for longer than two seconds.

The display shows the DSA menu.

- Press the softkey (5) with the display label "OFF".

"DSA OFF" appears on the display.

Note:

You can separately switch each module of the equalizer on or off in the respective menu (user EQ, sound presetting, DNC, stage effect and sound effect).

Switching DSA on

To reactivate the equalizer,

- press and hold the **AUDIO** button ⑩ for longer than two seconds.

The display shows the DSA menu.

- Press the softkey ⑤ with the display label "USER EQ".
- Select an equalizer setting.

Automatically calibrating the equalizer

You can perform and save electronic calibrations for three different situations (not possible if crossover is set), e.g.:

- EQ 1** For the driver alone
- EQ 2** For the driver and front passenger
- EQ 3** For the front and rear occupants

Hold the microphone in the appropriate position while the calibration is taking place.

The position of the calibration microphone for Situation 1 (e.g. for the driver alone) is at the height of the driver's head, approx. 10 centimetres next to the right ear.

For Situation 2, the calibration microphone should be positioned at head height between the driver and the front passenger.

For Situation 3, you should position the calibration microphone at head height in the centre of the vehicle interior (left/right, front/rear).

Really quiet surroundings are required for the calibration. Any extraneous noise will distort the measured values. Close all windows, doors, and the sliding sunroof during the calibration. You should be sitting in the driver's seat.

Note:

The sound radiating from the loudspeakers must not be obstructed by any objects. All the loudspeakers must be connected. The calibration microphone must be connected to the device, the calibration of the equalizer should be performed before the DNC calibration.

To calibrate an equalizer,

- press and hold the **AUDIO** button ⑩ for longer than two seconds.
- Press the softkey ⑤ with the display label "USER EQ".
- Press the softkey ⑤ with the display label of the equalizer ("EQ-1", "EQ-2" or "EQ-3") to be calibrated.
- Press the softkey ⑤ with the display label "ADJUST".
- Press the softkey ⑤ with the display label "AUTO ADJ".

A countdown is running on the display. During this time, you can position the calibration microphone. After the countdown expires, the calibration is performed.

- Use the same procedure for all equalizers.

After the calibration is complete, the menu of the selected equalizer is displayed again.

Viewing vehicle acoustics with/without equalizer

You can view the determined values for the vehicle acoustics. When viewing the settings, you can select between the equalizer view without equalization ("PRE EQ") and with equalization ("POST EQ").

- Press and hold the **AUDIO** button (10) for longer than two seconds.
- Press the softkey (5) with the display label "USER EQ".
- Press the softkey (5) with the display label of the equalizer to be viewed.
- Press the softkey (5) with the display label "ADJUST".
- Press the softkey (5) with the display label "MANUAL".

You can view the settings of the equalizer separately for the front and the rear loudspeakers.

Note:

If you already changed the graphical equalizer manually or if you have not yet performed a calibration, the softkeys described below cannot be selected.

If you want to select the view of the equalizer **without** equalization,

- Press the softkey (5) with the display label "VIEW PRE" on the left side of the display for front or on the right side for rear.

The setting of the equalizer is displayed.

If you want to select the view of the equalizer **with** equalization,

- press the softkey (5) with the display label "VIEWPOST" on the left side of

the display for front or on the right side for rear.

The setting of the equalizer is displayed.

To exit the view,

- press the **OK** joystick (8) or the **AUDIO** button (10).

Manually changing the graphical equalizer

The automatically determined values of the graphical equalizer can also be changed manually.

- press and hold the **AUDIO** button (10) for longer than two seconds.
- Press the softkey (5) with the display label "USER EQ".
- Press the softkey (5) with the display label of the equalizer to be set.
- Press the softkey (5) with the display label "ADJUST".
- Press the softkey (5) with the display label "MANUAL".

You can adjust the equalizer separately for the front and rear loudspeakers.

- Press the softkey (5) with the display label "FRONT EQ" for the front loudspeakers or "REAR EQ" for the rear loudspeakers.

The settings of the graphical equalizer are displayed.

To select the frequency,

- press the joystick (8) left or right until the desired frequency is displayed.
- Set the level for the frequency by moving the joystick (8) up or down.

While you are adjusting the equalizer, the values are graphically shown on the display.

- Perform all settings for both channels as described above.
- Press the **OK** joystick (8) or the **AUDIO** button (10) to exit the menu.

The settings are saved.

Selecting the Equalizer

After the calibration or the manual adjustment:

- Press and hold the **AUDIO** button (10) for longer than two seconds.
- Press the softkey (5) with the display label "USER EQ".
- Press the softkey (5) with the display label of the equalizer to be used.
- Press the **OK** joystick (8) or the **AUDIO** button (10) to exit the menu.

The settings are saved.

Resetting the equalizer

All automatically determined values of the selected equalizer can be reset.

- press and hold the **AUDIO** button (10) for longer than two seconds.
- Press the softkey (5) with the display label "USER EQ".
- Press the softkey (5) with the display label of the equalizer to be reset.
- Press the softkey (5) with the display label "ADJUST".
- Press and hold the softkey (5) with the display label "CLEAR" for longer than two seconds.

The automatically determined values of the equalizer are deleted.

- Press the **OK** joystick (8) or the **AUDIO** button (10) to exit the menu.

The settings are saved.

Selecting a sound presetting (Preset)

You can select sound presets for different music types. For a perfect sound, the pre-settings are "added" to the settings of the active user, i.e. the user EQs are optimised through the presettings for the various music styles.

Presettings for the following music styles are available:

- VOCAL
- DISCO
- ROCK
- JAZZ
- CLASSIC

The settings for these music styles have already been programmed.

- Press and hold the **AUDIO** button (10) for longer than two seconds.
- Press the softkey (5) with the display label "PRESET".
- Press the softkey (5) with the display label of the sound presetting to be used.
- Press the **OK** joystick (8) or the **AUDIO** button (10) to exit the menu.

The settings are saved.

Adjusting the stage effect

You can activate a stage effect that "relocates" the music in front of the driver or front passenger. This gives the impression of being directly in front of a stage. To refine this effect, you can change the virtual distance to your loudspeakers.

Selecting the stage effect

- Press and hold the **AUDIO** button (10) for longer than two seconds.
- Press the softkey (5) with the display label "CH DELAY".
- Press the softkey (5) with the display label "ON" to activate the stage effect.
- Press the softkey (5) with the display label "OFF" to deactivate the stage effect.
- Press the softkey (5) with the display label "LRSWAP" to mirror the settings.
- Press the softkey (5) with the display label "ADJUST" to set the distance of the loudspeakers.

A submenu appears. For further information, please read the next section.

Changing the virtual distance of the loudspeakers

To further optimise the stage effect, you can adjust the distance of the individual loudspeakers built into the vehicle with respect to the left front seat. You can adjust the distance to the front and to the rear loudspeakers from 0-275 cm.

- Press the softkey (5) with the display label "ADJUST" in the "Digital Staging Menu".

- Select the softkey with the assignment of the loudspeaker for which you want to set the distance.

"RR" is right rear, "LR" left rear, "RF" right front and "LF" left front.

If crossover is activated, different symbols appear ("Lhigh" for "LF", "Rhigh" for "RF", "Llow" for "LR" and "Rlow" for "RR").

- Turn the volume control (2) or move the joystick (8) to set the distance.
- Press the **OK** joystick (8) or the **AUDIO** button (10) to exit the menu.

The settings are saved.

Selecting a sound effect

You can select from different sound effects for your music:

- CATHEDRAL
- THEATER
- CONCERT
- CLUB
- STADIUM

The sound effects have already been programmed.

- Press and hold the **AUDIO** button (10) for longer than two seconds.
- Press the softkey (5) with the display label "EFFECTS".
- Press the softkey (5) with the display label of the sound effect to be used.

If you do not want to use any sound effects,

- press the softkey (5) with the display label "OFF".
- Press the **OK** joystick (8) or the **AUDIO** button (10) to exit the menu.

The settings are saved.

DNC

Dynamic Noise Covering

DNC allows for raising a volume when driving that is considered pleasant for a non-driving vehicle.

The increase differs according to frequency ranges, dependent upon the noise development of the vehicle.

Hence, volume and sound remain at a pleasant level even with changing noise developments. Short-term noises, such as those while crossing railways, are not considered.

Calibrating DNC

A calibration via the measurement microphone is required for vehicle-specific operation. The DNC calibration should be performed after the DSA calibration. Before the calibration, you should permanently attach the calibration microphone with the supplied Velcro tape near the console, but not in the floor area, at droning points or at the heating/ventilation.

The opening of the calibration microphone must point to the direction of the passenger compartment. The calibration should be performed at a quiet location with the engine switched off. The doors, windows and sunroof must remain closed, and you should be seated in the driver's seat.

Starting the DNC calibration

- Press and hold the **AUDIO** button (10) for longer than two seconds.
- Press the softkey (5) with the display label "DNC".
- Press the softkey (5) with the display label "ADJUST".

A countdown is running on the display. After the countdown expires, the calibration is performed.

- Press the **OK** joystick (8) or the **AUDIO** button (10) to exit the menu.

Switching DNC off

To deactivate the DNC,

- press and hold the **AUDIO** button (10) for longer than two seconds.
- Press the softkey (5) with the display label "DNC".
- Press the softkey (5) with the display label "OFF".

"DNC OFF" appears on the display.

To reactivate the DNC,

- select a DNC increase (DNC1 - DNC5).
- Press the **OK** joystick (8) or the **AUDIO** button (10) to exit the menu.

The settings are saved.

Selecting a DNC increase

You can adjust the DNC increase, i.e. the sensitivity of the increase in volume and sound, in five increments.

The setting "DNC 1" is suitable for vehicles with loud engines and bass-loaded music. The setting "DNC 5" is suitable for vehicles with quiet engines and for classical music. You will need to test various settings to find the most suitable one for your taste.

To select a DNC increase,

- press and hold the **AUDIO** button (10) for longer than two seconds.
- Press the softkey (5) with the display label "DNC".
- Press the softkey (5) with the display label "LEVEL".
- Adjust the increase using the joystick (8).
- Press the **OK** joystick (8) or the **AUDIO** button (10) to exit the menu.

The settings are saved.

Subwoofer and centre speaker

You can connect a subwoofer and a centre speaker to this device.

To further optimise the sound when using a subwoofer and centre speaker, you can adjust a low-pass filter for the subwoofer and one high-pass filter each for front and rear.

Adjusting the subwoofer increase

You can adjust a permanent volume increase or decrease for the connected subwoofer from -6 to +6 and thereby increase or decrease the bass response of the subwoofer. The setting to be selected depends upon the installation position and installation location of the subwoofer in your vehicle. You may need to test various settings to find the most suitable one for your taste.

- Press the **AUDIO** button (10).

"AUDIO MENU" appears on the display.

- Press the softkey (5) with the display label "SUBOUT".
- Press the softkey (5) with the display label "GAIN".
- Move the joystick (8) up or right to increase the level or down or left to decrease the level.

When you have finished making your changes,

- press the **OK** joystick (8) or the **AUDIO** button (10).

Adjusting the subwoofer phase position

You can adjust the phase position of the subwoofer output to your subwoofer and select between "-135°" and "180°" in increments of 45°.

➤ Press the **AUDIO** button (10).

"AUDIO MENU" appears on the display.

➤ Press the softkey (5) with the display label "SUBOUT".

➤ Press the softkey (5) with the display label "PHASE".

➤ Move the joystick (8) to select from the possible settings.

When you have finished making your changes,

➤ press the **OK** joystick (8) or the **AUDIO** button (10).

Setting the low-pass filter

The low-pass filter allows you to define a frequency up to which the subwoofer will operate. All signals above the defined frequency are "cut off" and not passed on to the subwoofer.

You can select from the frequencies "40 Hz", "50 Hz", "63 Hz" and "100 Hz". If your subwoofer features a built-in low-pass filter, you can also select the setting "FLAT" and thereby forward all frequencies to the subwoofer.

Please adjust this setting to the frequency range and the capabilities of your subwoofer. For further details, please read the documentation of the subwoofer.

➤ Press the **AUDIO** button (10).

"AUDIO MENU" appears on the display.

➤ Press the softkey (5) with the display label "SUBOUT".

➤ Press the softkey (5) with the display label "LOWPASS".

➤ Move the joystick (8) to select from the possible settings.

When you have finished making your changes,

➤ press the **OK** joystick (8) or the **AUDIO** button (10).

Setting the subsonic filter

To avoid interferences from extremely low frequencies, you can use the subsonic filter to limit the low-frequency response of the device. This is particularly useful for small subwoofers. The setting of the subsonic filter suppresses all frequencies below the defined frequency. When setting the subsonic filter, you should orient yourself by means of the loudspeaker setup of your vehicle.

You can select from the frequencies "20 Hz", "25 Hz", "32 Hz" and "40 Hz". In addition, you can set the quality factor "Q" for the selected frequency in five increments: "Q1"=0.5, "Q2"=0.7, "Q3"=0.9, "Q4"=1.1 and "Q5"=1.3.

If you select the setting "FLAT", the frequency response of the device is not affected.

➤ Press the **AUDIO** button (10).

"AUDIO MENU" appears on the display.

➤ Press the softkey (5) with the display label "SUBOUT".

➤ Press the softkey (5) with the display label "SUBSONIC".

- Move the joystick (8) left or right to select among the available frequencies.
- Move the joystick (8) up or down to select the desired quality factor for the defined frequency.

When you have finished making your changes,

- press the **OK** joystick (8) or the **AUDIO** button (10).

Adjusting the centre speaker

You can select the frequency at which a connected centre speaker should be controlled.

You can select from the frequencies "200 Hz", "400 Hz", "800 Hz", "1600 Hz" and "3200 Hz". If you select the setting "FLAT", all frequencies are output via the centre speaker, including bass. This setting should be selected only if your centre speaker features a built-in high-pass filter.

In addition to the frequency, you can adjust the level for the centre speaker.

- Press the **AUDIO** button (10).
"AUDIO MENU" appears on the display.
- Press the **NEXT** button (4).
"AUDIO MENU 2" appears on the display.
- Press the softkey (5) with the display label "CENTRE".
- Press the joystick (8) left or right to adjust the frequency for the centre speaker.
- Press the joystick (8) up or down to adjust the level for the centre speaker.

When you have finished making your changes,

- press the **OK** joystick (8) or the **AUDIO** button (10).

Adjusting high-pass filters for front/rear

You can adjust a separate high-pass filter for the front and the rear channel that filters all frequencies below the adjusted frequency so that the filtered frequencies are played only by a connected subwoofer.

If you select the setting "FLAT", no frequencies are filtered and all signals are forwarded to the loudspeakers. The setting "AUTO" automatically adjusts the high-pass filter to the value defined for the low-pass filter.

- Press the **AUDIO** button (10).
"AUDIO MENU" appears on the display.
- Press the **NEXT** button (4).
"AUDIO MENU 2" appears on the display.
- Press the softkey (5) with the display label "HIPASS F" for setting the front high-pass filter.

Or

- Press the softkey (5) with the display label "HIPASS R" for setting the rear high-pass filter.
- Press the joystick (8) left or right to adjust the frequency for the high-pass filter.

When you have finished making your changes,

- press the **OK** joystick (8) or the **AUDIO** button (10).

Crossover

In crossover mode, the high frequencies are played via the front channels and the low frequencies via the rear channels.

➤ Press the **AUDIO** button (10).

"AUDIO MENU" appears on the display.

➤ Press the **NEXT** button (4).

"AUDIO MENU 2" appears at the bottom of the display.

➤ Press the softkey (5) with the display label "CROSSOVR".

Crossover is now adjusted.

To be able to use the crossover mode, you must set the high-pass filter and the low-pass filter.

➤ Press the softkey (5) with the display label "HIPASS" for setting the high-pass filter.

➤ Press the joystick (8) left or right to adjust the frequency for the high-pass filter.

➤ Press the softkey (5) with the display label "LOWPASS" for setting the low-pass filter.

➤ Press the joystick (8) left or right to adjust the frequency for the high-pass filter.

The settings are automatically saved.

TMC for dynamic navigation systems

TMC stands for "Traffic Message Channel". Traffic reports are broadcast digitally via TMC, which means they can be used by compatible navigation systems during route planning. Your car sound system has a TMC output, which you can use for connecting Blaupunkt navigation systems. You can find out from your Blaupunkt dealer which navigation systems can be used with your car sound system.

Amplifier/Sub-Out

The car sound system provides connections that allow you to connect external amplifiers. In addition, you can connect a subwoofer to the integrated low-pass filter of the device. For this purpose, the amplifier and subwoofer must be connected as described in the installation instructions.

We recommend you use well-matched products from the Blaupunkt or Velocity product ranges.

Switching the internal amplifier on/off

If you are using external amplifiers, you can switch off the device's internal amplifier ("Internal Amp Off" setting).

Note:

Please check this setting if the loudspeakers do not emit any sound.

- Press the **MENU** button (9).
- Press the softkey (5) with the display label "VARIOUS".
- Press the softkey (5) with the display label "AMP ON" repeatedly until the desired setting "INTERNAL AMP ON" or "INTERNAL AMP OFF" appears.

If the internal amplifier is switched on, the softkey "AMP ON" is highlighted in dark.

- Press the **OK** joystick (8) or the **MENU** button (9) to exit the menu.

The settings are saved.

External audio sources

You can connect up to two external audio sources to the device. Audio sources can, for example, be portable CD players, Mini Disc players or MP3 players.

The first external audio source can be connected **instead of** a CD changer (AUX1).

The second external audio source (AUX2) can be connected **in addition** to the CD changer or AUX1.

Instead of AUX2, you can connect a navigation system. For further details, read the section "Navigation audio" in the chapter "Adjusting the volume".

To be able to use the AUX inputs, you must activate the AUX inputs in the setup menu.

If you want to connect an external audio source, you will need an adapter cable. This cable is available from a specialised Blaupunkt dealer.

Switching the AUX input on/off

- Press the **MENU** button (9).
- Press the softkey (5) with the display label "AUX".

The AUX menu is displayed.

If no CD changer is connected and you want to connect an external audio source,

- press the softkey (5) with the display label "AUX1".

With every press of the softkey "AUX1", you can switch between the settings "AUXILIARY 1 ON" and "AUXILIARY 1 OFF".

If no navigation system is connected and you want to connect an external audio source,

- press the softkey (5) with the display label "NAV/AUX2".

With every press of the softkey "NAV/AUX2", you can switch between the settings "AUXILIARY 2 ON" and "NAVIGATION ON".

Note:

If a CD changer is connected, the input "AUX1" cannot be changed.

- Press the **OK** joystick (8) or the **MENU** button (9) to exit the menu.

The settings are saved.

Note:

If the AUX inputs are activated, they can be selected using the **SOURCE** button (12).

Naming the AUX input

You can name the AUX inputs, to be better able to assign them during the source selection with the **SOURCE** button (12) (e.g., you can use the device name of the connected device).

- Press the **MENU** button (9).
- Press the softkey (5) with the display label "AUX".

The AUX menu is displayed.

- Press the softkey (5) with the display label "EDIT" under "AUX1" or "NAV/AUX2".

The display shows the standard text for the selected input. The input mark is at the beginning of the line and flashing.

To enter a name,

- press the joystick (8) left or right to move the input mark.
- Set the desired letter by pushing the joystick (8) up or down.
- After entering the name, press the **OK** joystick (8) or the **MENU** button (9) to exit the menu.

The settings are saved.

Miscellaneous

Entering a switch-on message

If you switch on the device, a brief message is shown on the display as scrolling text. This text is factory set to "BLAUPUNKT-THE ADVANTAGE IN YOUR CAR". Instead, you can enter your own text of up to 35 characters.

- Press the **MENU** button (9).
- Press the softkey (5) with the display label "VARIOUS".
- Press the softkey (5) with the display label "ON MSG".

The display shows the standard text for the switch-on message. The input mark is at the beginning of the line and flashing.

To input a different text,

- press the joystick (8) left or right to move the input mark.
- Set the desired letter by pushing the joystick (8) up or down.
- After entering the message, press the **OK** joystick (8) or the **MENU** button (9) to exit the menu.

The settings are saved.

Displaying the serial number

You can display the serial number of the device.

- Press the **MENU** button (9).
- Press the softkey (5) with the display label "VARIOUS".
- Press the softkey (5) with the display label "SER NUM".

The serial number of the device is displayed in the top line of the display.

- Press the **OK** joystick (8) or the **MENU** button (9) to exit the menu.

Resetting the device

You can reset the device to the factory-pre-set parameters. All personal settings are lost in the process.

- Press the **MENU** button (9).
- Press the softkey (5) with the display label "VARIOUS".
- Press and hold the softkey (5) with the display label "NORMSET" for longer than two seconds.

The device switches off and automatically on again.

Specifications

Amplifier

Output power:	4 x 18 watts sine at 14.4 V and 1% distortion factor at 4 ohms. 4 x 26 watts sine in accordance with DIN 45324 at 14.4 V at 4 ohms. 4 x 50 watts max. power
---------------	--

Tuner

Wavebands:	
FM:	87.5 – 108 MHz
MW:	531 – 1 602 kHz
LW:	153 – 279 kHz
SW:	5.85 – 6.30 MHz (49-m band)

FM frequency response:	20 – 16,000 Hz
------------------------	----------------

CD

Frequency response:	15 – 20,000 Hz
---------------------	----------------

Pre-amp out

4 channels:	4 V / < 1 k Ω
-------------	----------------------

AUX input

Input sensitivity:	1.2 V / 10 k Ω
--------------------	-----------------------

Weight	1.45 kg
---------------	---------

Subject to changes!

Bitte den ausgefüllten Gerätepass sicher aufbewahren!

Please keep the filled-in radio pass in a safe place!

Prière de conserver soigneusement la carte d'autoradio remplie !

Tenete per favore il libretto di apparecchio, debitamente riempito, in un posto sicuro!

Bewaar de ingevulde apparaatpas op een veilige plaats!

Vänligen förvara ifyllt apparatpass på säker plats!

Country:	Phone:	Fax:	WWW:
Germany	(D) 0180-5000225	05121-49 4002	http://www.blaupunkt.com
Austria	(A) 01-610 39 0	01-610 39 391	
Belgium	(B) 02-525 5444	02-525 5263	
Denmark	(DK) 44 898 360	44-898 644	
Finland	(FIN) 09-435 991	09-435 99236	
France	(F) 01-4010 7007	01-4010 7320	
Great Britain	(GB) 01-89583 8880	01-89583 8394	
Greece	(GR) 210 94 27 337	210 94 12 711	
Ireland	(IRL) 01-46 66 700	01-46 66 706	
Italy	(I) 02-369 62331	02-369 62464	
Luxembourg	(L) 40 4078	40 2085	
Netherlands	(NL) 00 31 24 35 91 338	00 31 24 35 91 336	
Norway	(N) +47 64 87 89 60	+47 64 87 89 02	
Portugal	(P) 2185 00144	2185 00165	
Spain	(E) 902 52 77 70	91 410 4078	
Sweden	(S) 08-7501850	08-7501810	
Switzerland	(CH) 01-8471644	01-8471650	
Czech. Rep.	(CZ) 02-6130 0446	02-6130 0514	
Hungary	(H) 76 511 803	76 511 809	
Poland	(PL) 0800-118922	022-8771260	
Turkey	(TR) 0212-335 06 71	0212-346 00 40	
USA	(USA) 800-2662528	708-6817188	
Brasil (Mercosur)	(BR) 0800 7045446	+55-19 3745 2773	
Malaysia (Asia Pacific)	(MAL) +604-6382 474	+604-6413 640	

Gerätepass

Name: **Bremen MP76**

Typ: **7 646 828 310**

Serien-Nr: **BP**

 **BLAUPUNKT**

Blaupunkt GmbH, Robert-Bosch-Straße 200, D-31139 Hildesheim

04/06 - CM-AS/SCS

(dt, gb, fr, it, nl, sw)



8622405008

CE