



IMI CORNELIUS INC ■ One Cornelius Place ■ Anoka, MN 55303-6234

Telephone (800) 238-3600

Facsimile (612) 422-3246

Installation Manual

ICE/BEVERAGE DISPENSER

Model: ED 300 BN

IMPORTANT:

TO THE INSTALLER.

It is the responsibility of the installer to ensure that the water supply to the dispensing equipment is provided with protection against backflow by an air gap as defined in ANSI/ASME A112.1.2-1979; or an approved vacuum breaker or other such method as proved effective by test.

Water pipe connections and fixtures directly connected to a potable water supply shall be sized, installed, and maintained according to Federal, State, and Local Codes.

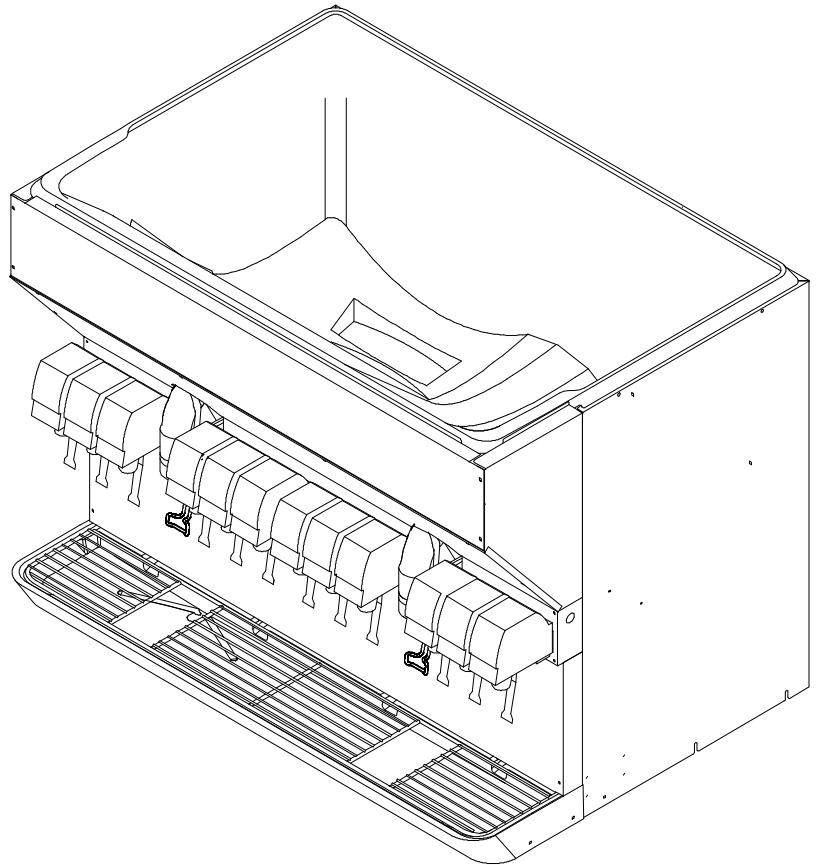

Part No. 620913202
October 28, 1998
Revision A

THIS DOCUMENT CONTAINS IMPORTANT INFORMATION

This Manual must be read and understood before installing or operating this equipment

TABLE OF CONTENTS

	Page
SAFETY PRECAUTIONS	1
DESCRIPTION	1
SPECIFICATIONS	1
INSTALLATION INSTRUCTIONS	2
MAINTENANCE	8
GATE RESTRICTOR PLATE	8
ADJUSTMENT	8
REMOVAL AND REPLACEMENT OF AGITATORS	9
TROUBLESHOOTING	10
BLOWN FUSE OR CIRCUIT BREAKER.	10
GATE DOES NOT OPEN. AGITATOR DOES NOT TURN.	10
GATE DOES NOT OPEN OR IS SLUGGISH. AGITATOR TURNS.	10
ICE DISPENSES CONTINUOUSLY.	10
SLUSHY ICE. WATER IN HOPPER.	10
BEVERAGES DO NOT DISPENSE.	10
BEVERAGES TOO SWEET.	10
BEVERAGE NOT SWEET ENOUGH.	11
AGITATORS TURN IN OPPOSITE DIRECTIONS	11
ICE DOES NOT DISPENSE FROM ONE GATE ASSEMBLY	11
WARRANTY	14

LIST OF FIGURES

FIGURE 1. INSTALLATION DIMENSIONS	3
FIGURE 2. INSTALLATION REAR VIEW	4
FIGURE 3. MOUNTING TEMPLATE	5
FIGURE 4. DRIP TRAY DRAIN HOOK-UP	6
FIGURE 5. BEVERAGE SYSTEM SCHEMATIC	7
FIGURE 6. GATE RESTRICTOR PLATE	8
FIGURE 7. AGITATOR REMOVAL AND REPLACEMENT	9
FIGURE 8. WIRING DIAGRAM	12
FIGURE 9. LADDER SCHEMATIC	13

SAFETY PRECAUTIONS

Always: disconnect power to the dispenser before servicing or cleaning.

Never: place hands inside of hopper or gate area without disconnecting power to the dispenser. Agitator rotation occurs automatically when dispenser is energized!

This ice dispenser has been specifically designed to provide protection against personal injury and eliminates contamination of ice. To insure continued protection and sanitation, observe the following:

ALWAYS: be sure the rear manual ice fill lid is properly installed to prevent unauthorized access to the hopper interior and possible contamination of the ice.

ALWAYS: be sure the upper and lower front panels are securely fastened.

ALWAYS: keep area around the dispenser clean of ice cubes.

The sink can be easily and quickly removed. The unit must never be lifted or moved by the sink.



CAUTION: Dispenser cannot be used with crushed or flaked ice. Use of bagged ice which has frozen into large chunks can void warranty. The dispenser agitator is not designed to be an ice crusher. Use of large chunks of ice which "jam up" inside the hopper will cause failure of the agitator motor and damage to the hopper. If bagged ice is used, it must be carefully and completely broken into small, cube-sized pieces before filling into the dispenser hopper.

DESCRIPTION

The "ENDURO" series of ice dispensers solves your ice and beverage service needs in the sanitary, space saving, economical way. Designed to be automatically filled with ice from a top mount ice maker, these dispensers will dispense cubes (up to 1-1/4" in size), cubelets and hard-chipped or cracked ice; and, in addition, several flavors of post-mix beverages. "B" units include beverage faucets and are designed to be supplied from syrup containers and a carbonator through a remote refrigeration system for cooling the product and water lines.

SPECIFICATIONS

Model:	ED300 BN (ENDURO300 BN)
Ice Storage:	300 lbs
Maximum Number of Faucets Available:	12 maximum
Built-in Cold Plate:	No
Electrical:	120/1/60, Amps - 5.2 total unit draw
Dimensions:	44-3/8" Wide X 31-1/2" Deep X 36-1/4" High

INSTALLATION INSTRUCTIONS

IMPORTANT: It is the responsibility of the Installer to ensure that the water supply to the dispensing equipment is provided with protection against backflow by an air gap as defined in ANSI/ASME A112 1.2-1979; or an approved vacuum breaker or other such method as proved effective by test.

Water pipe connections directly connected to a potable water supply *shall* be sized, installed, and maintained according to Federal, State, and local codes.

All drain connections *must* be installed with adequate backflow protection to prevent contamination of the potable water supply and the ice storage hopper in accordance with Federal, State, and local codes.

1. Locate the Dispenser indoors on a level countertop. The Dispenser must be sealed to the countertop. Using the mounting template (see Figure 3), determine the outline of the Dispenser and the six mounting holes for the desired location of the Dispenser. Remove the (6) plastic hole plugs from the threaded base mounting holes, the two base black plastic panels, and the two rear stainless steel cabinet access panels. Apply a continuous bead of NSF International (NSF) listed silastic sealant (Dow Corning 732 or equal) around the outline of the Dispenser on the countertop. Position the Dispenser on the countertop and wipe away any excess sealant immediately. Bolt the Dispenser to the countertop with 3/8-16 bolts.
2. The beverage and water manifold inlet lines, ice storage hopper drain tubes (2), and electrical power cord are routed through the two large openings in the base of the Dispenser. Access for these hook-ups is provided through the two rear cabinet openings.
3. Connect the (2) hopper drain tubes to an approved drain system with a backflow preventer in compliance to the local plumbing code. *Do not* "tee" into the drip tray drain line.
4. DRIP TRAY DRAIN ASSEMBLY: Route the drain tube to an open drain with the end of the tube above the "flood" level of the drain. Use the tubing, fittings, clamps, and insulation provided with the Dispenser to assemble the drain. The completed drain line *must* pitch continuously downward and contain no "traps" or improper drainage will result.
5. BEVERAGE SYSTEM: Connect the beverage system product lines to the Dispenser. Consult the water manifold hook-up schematic located on the front panel of the Dispenser to determine the connections for the Dispenser's internal water manifold for the desired non-carb and carbonated valve positions. These connections *should* be performed by a qualified Service Person.
6. Replace the two rear stainless steel cabinet panels after completing the hook-ups. Seal these access panels to the countertop with the approved sealant from step 1.
7. Clean the ice storage hopper interior (see CLEANING INSTRUCTIONS in the Owner's manual).
8. Connect the power cord to a 120 VAC, 60 Hz 3-wire grounded receptacle.

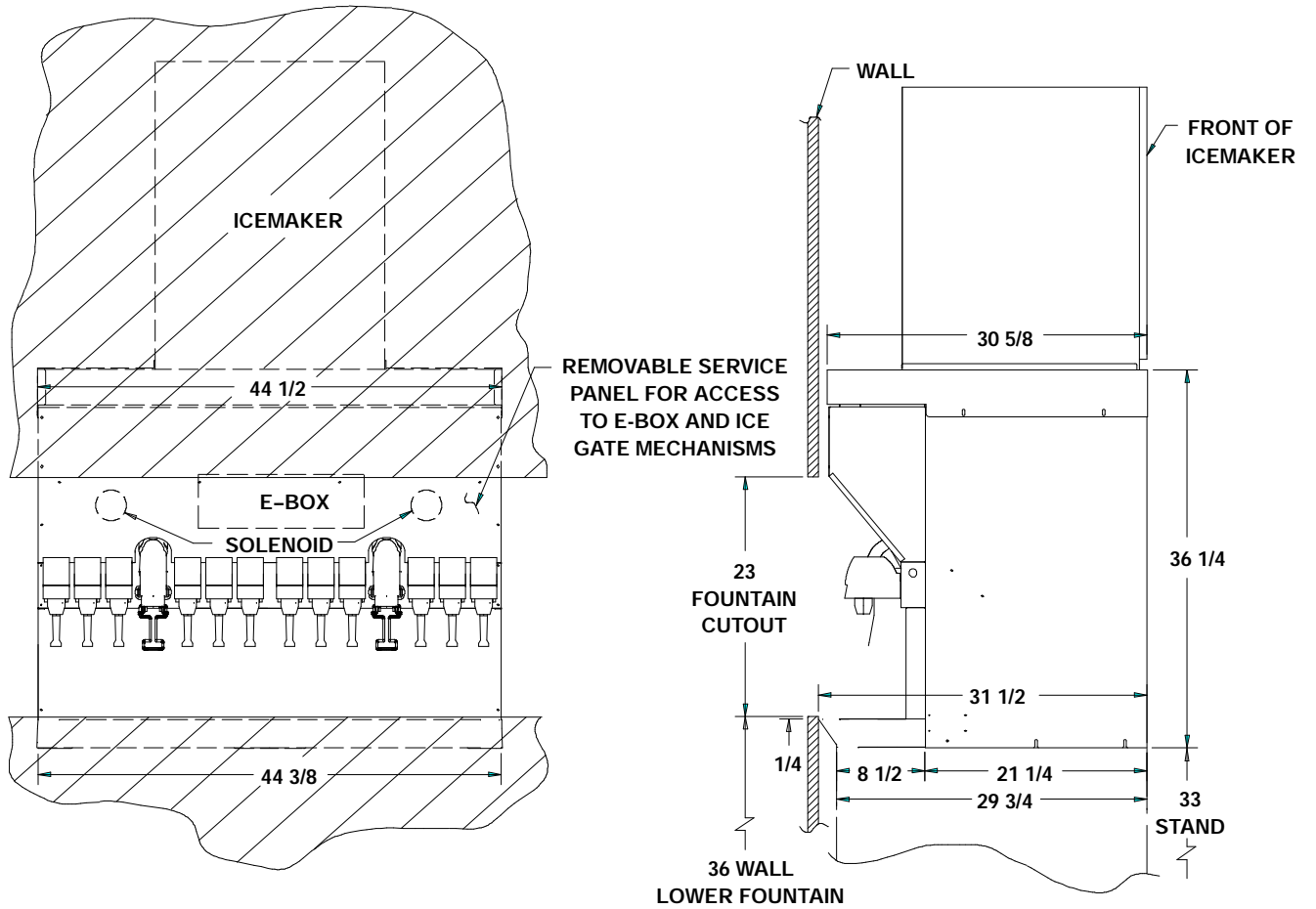

FIGURE 1. INSTALLATION DIMENSIONS

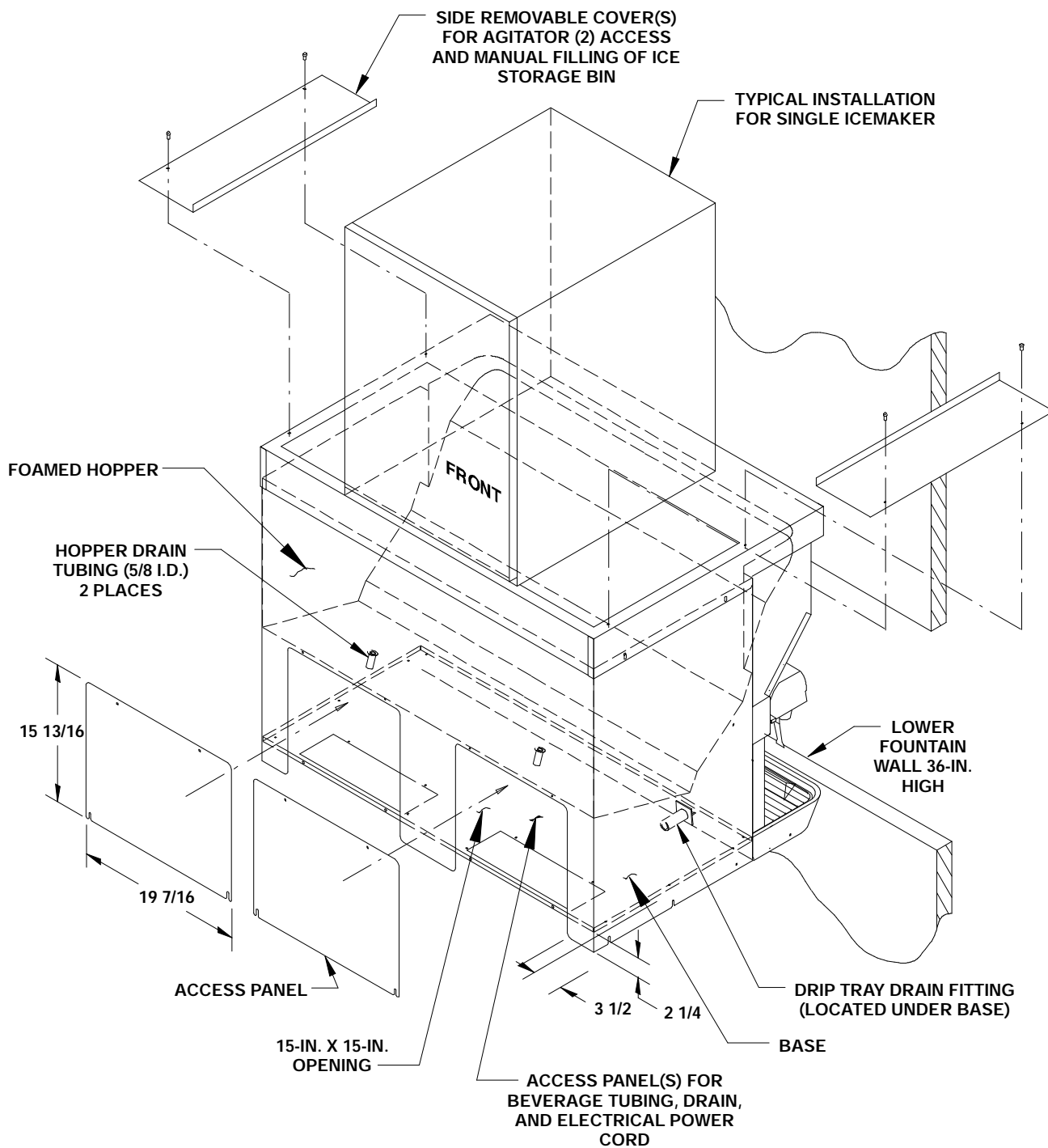
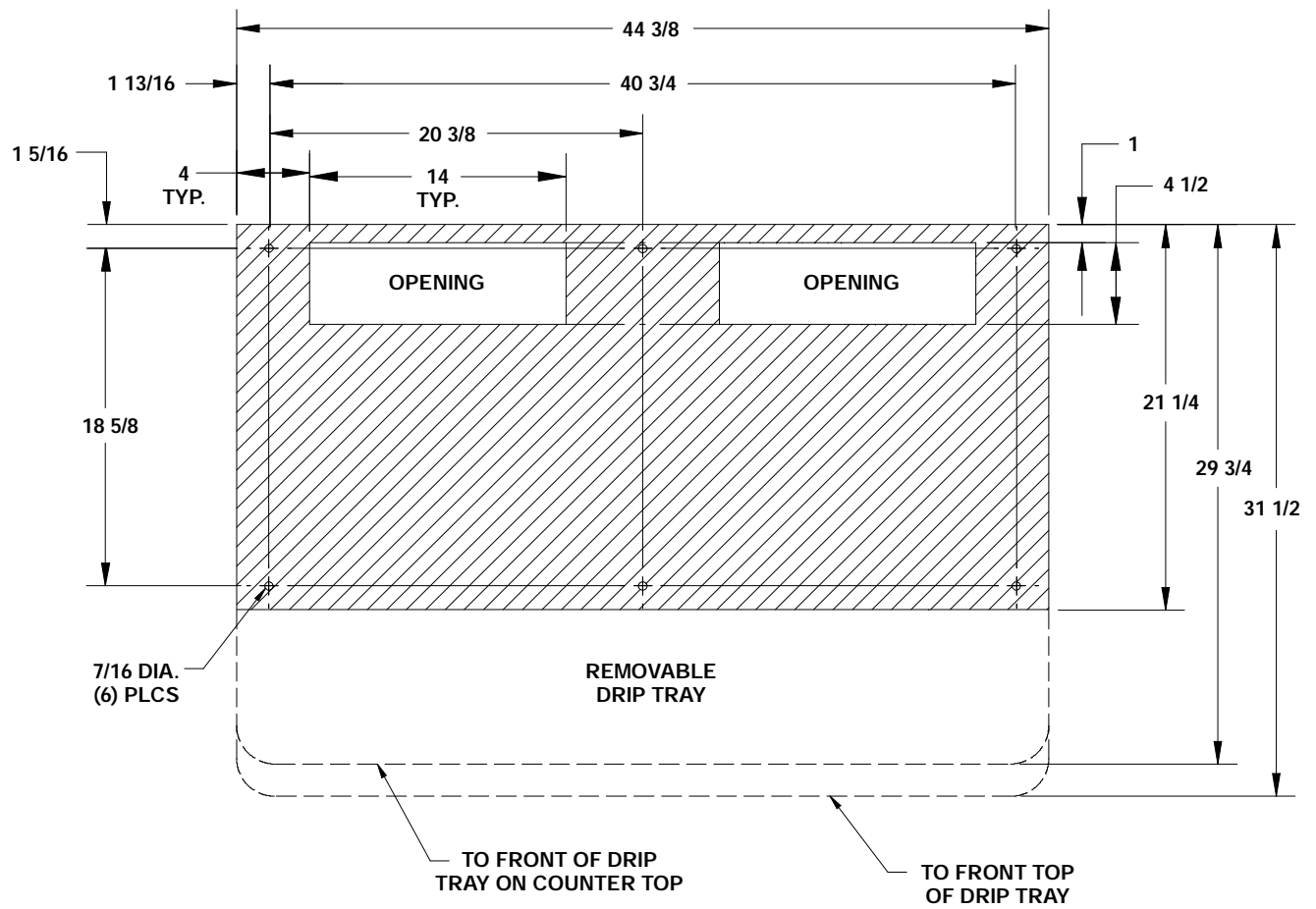

FIGURE 2. INSTALLATION REAR VIEW



OPENING (2) IN UNIT BASE FOR BEVERAGE AND
 WATER MANIFOLD INLET LINES, HOPPER DRAIN
 LINES (2), AND ELECTRICAL SUPPLY GROUND.

FIGURE 3. MOUNTING TEMPLATE

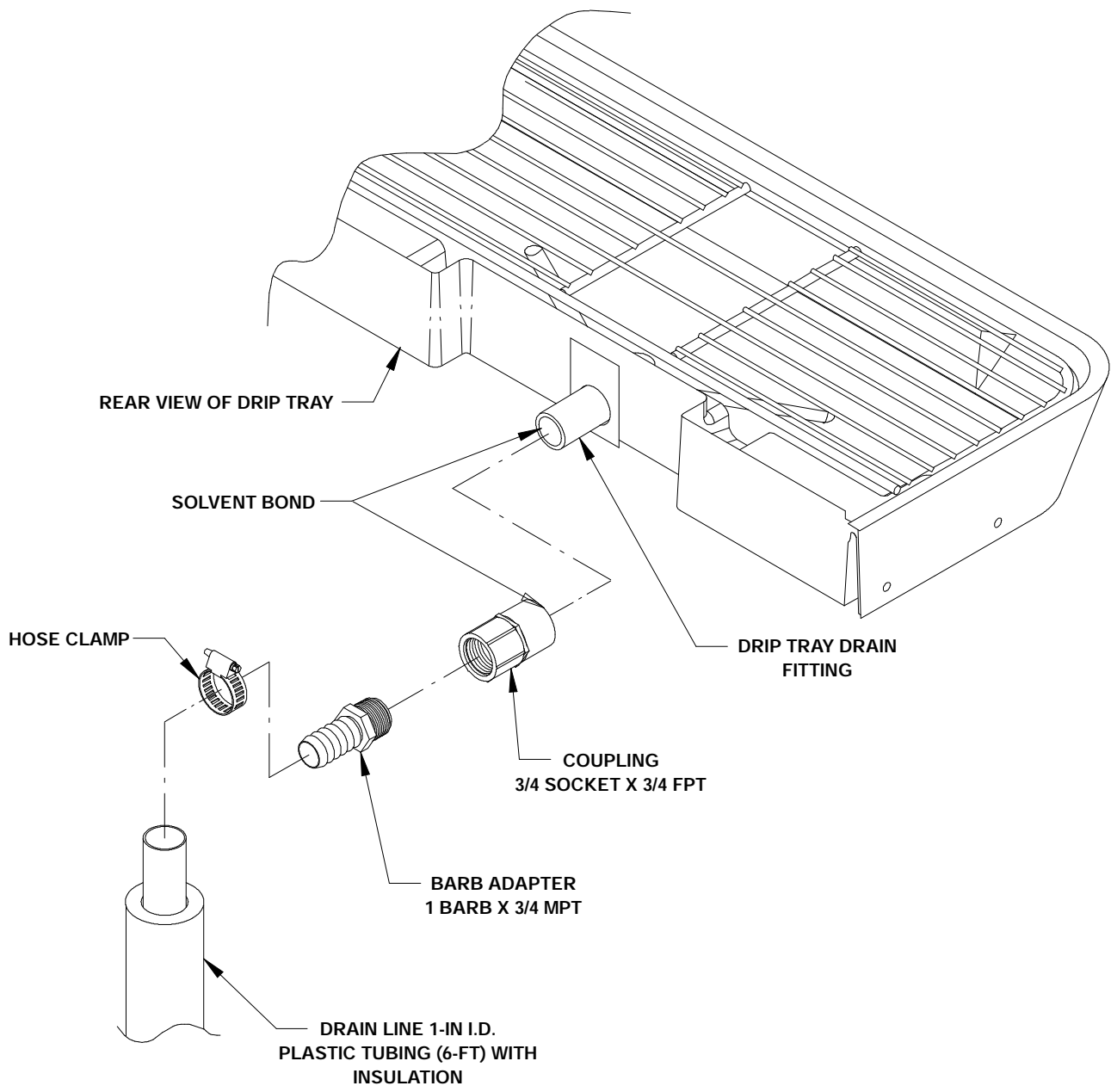

FIGURE 4. DRIP TRAY DRAIN HOOK-UP

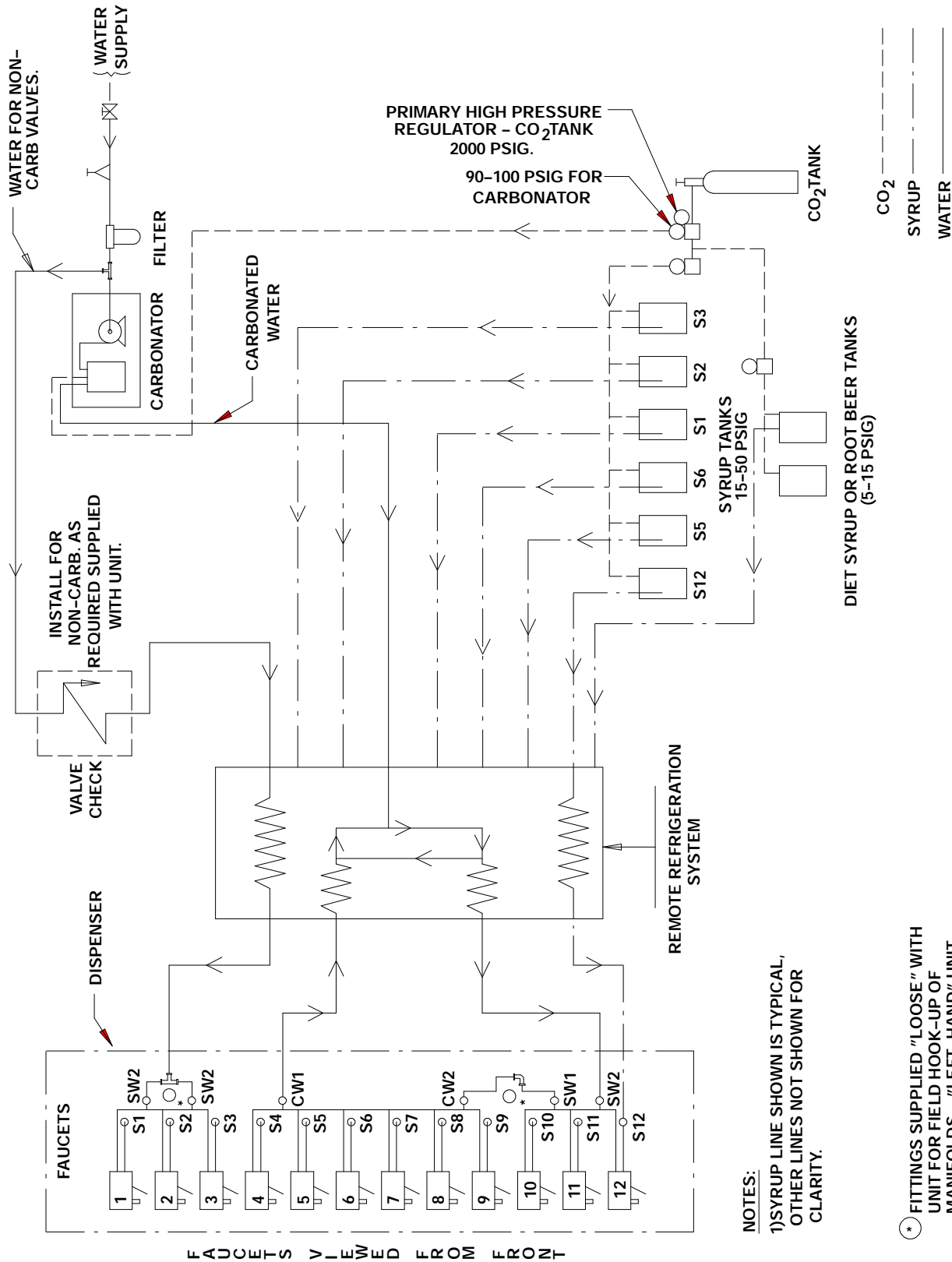

FIGURE 5. BEVERAGE SYSTEM SCHEMATIC

NOTES:

1) SYRUP LINE SHOWN IS TYPICAL, OTHER LINES NOT SHOWN FOR CLARITY.

* FITTINGS SUPPLIED "LOOSE" WITH UNIT FOR FIELD HOOK-UP OF MANIFOLDS - "LEFT-HAND" UNIT SHOWN.

MAINTENANCE

GATE RESTRICTOR PLATE



CAUTION: Disconnect power to dispenser before installing, removing or adjusting restrictor.

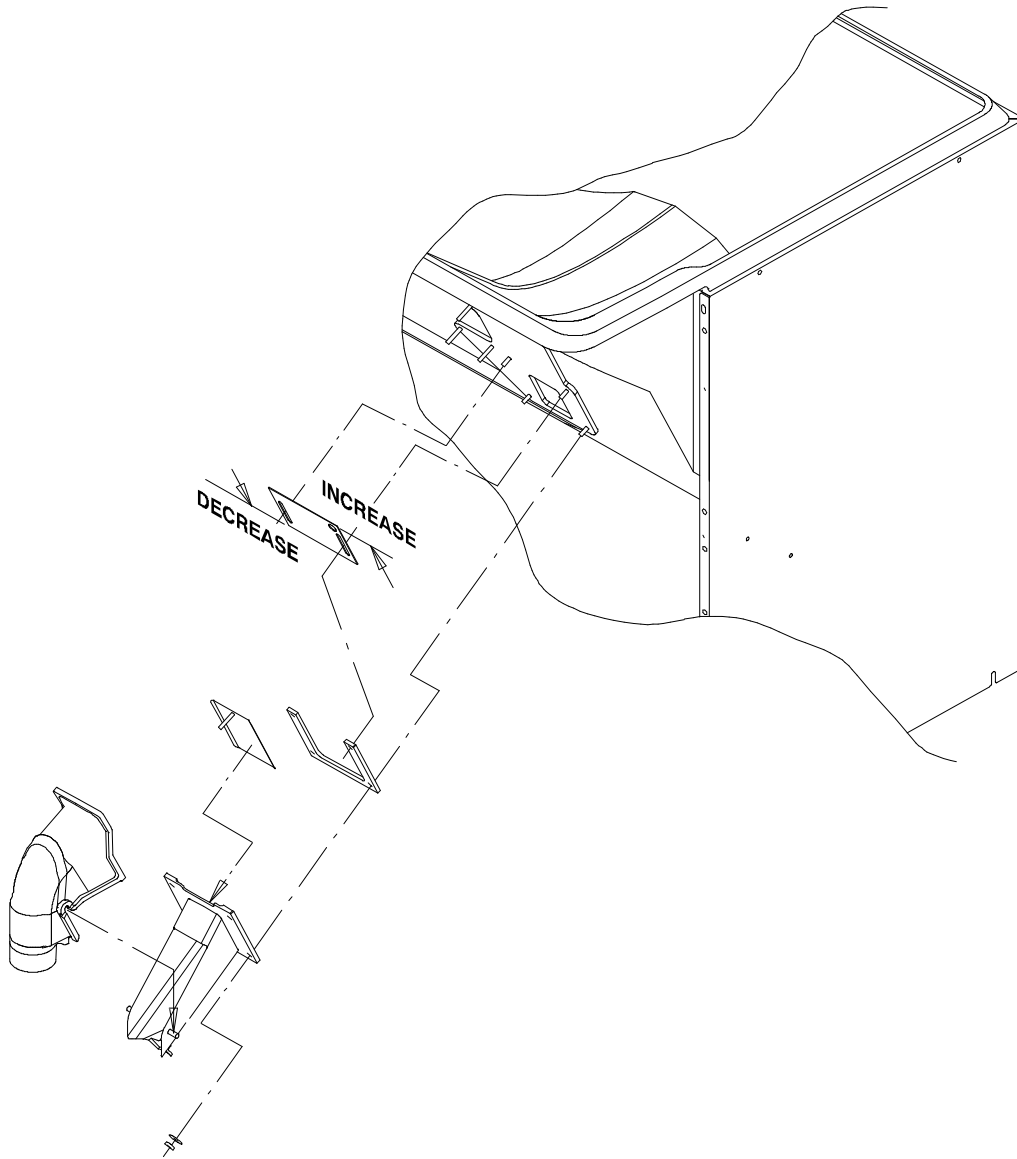

FIGURE 6. GATE RESTRICTOR PLATE

ADJUSTMENT

This plate may be adjusted as shown to reduce or increase with large containers the dispensing rate of ice, especially desirable when using glasses or other containers with small openings. Adjustment can be made by sliding up or down with nuts loosened, to obtain the desired amount of restriction.

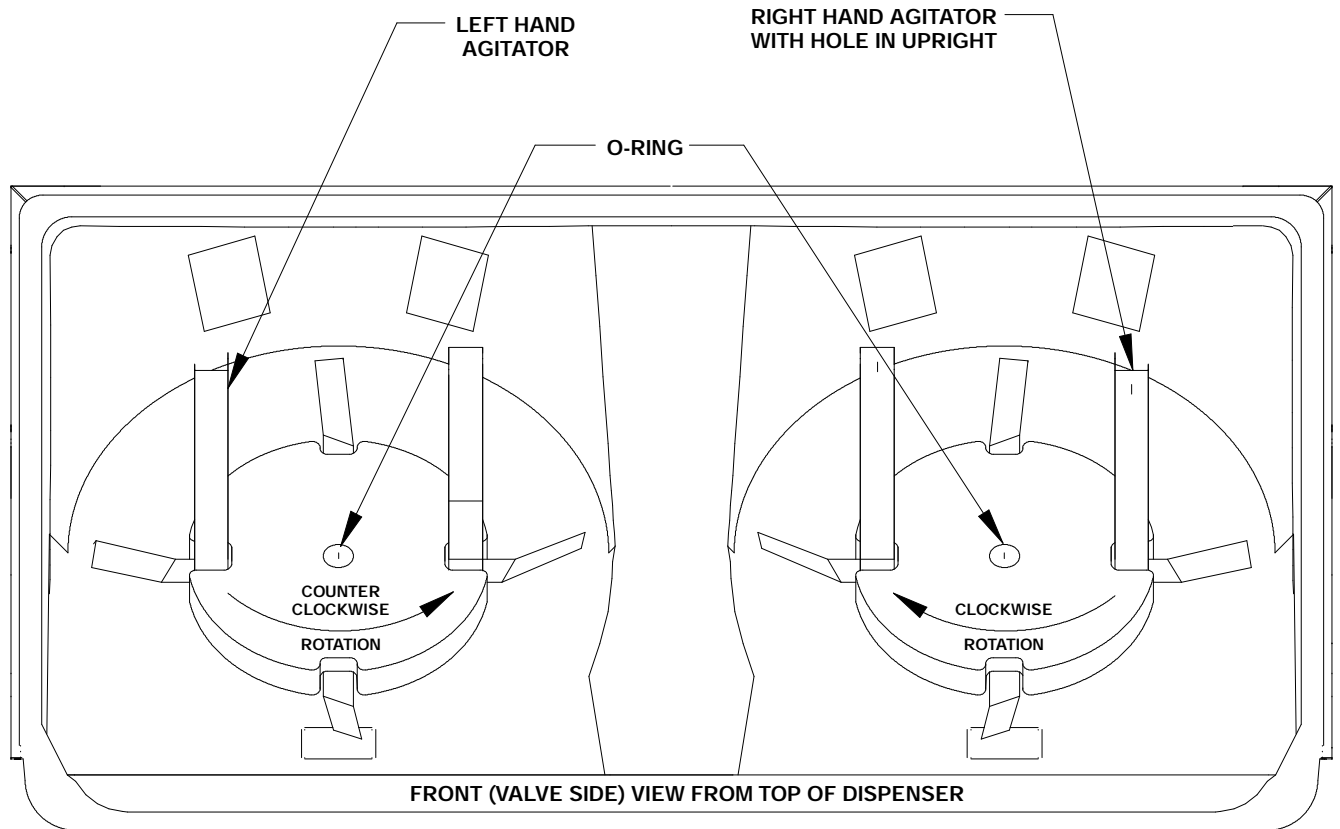

FIGURE 7. AGITATOR REMOVAL AND REPLACEMENT

REMOVAL AND REPLACEMENT OF AGITATORS

Remove agitators for cleaning as follows:

1. Lift agitator and disc from Dispenser.
2. Remove O-Ring, starting at notch. Warm the O-ring with water to ease removal.
3. Lift the plastic agitator disk off of the stainless steel agitator.
4. Grip agitator at the center and pull up.
5. To replace, reverse steps.

NOTE: Refer to Sanitize Procedure in the Owner's Instruction for complete cleaning and sanitizing instructions.

TROUBLESHOOTING

IMPORTANT: Only qualified personnel should service internal components or electrical wiring.



WARNING: If repairs are to be made to a product system, remove quick disconnects from the applicable product tank, then relieve the system pressure before proceeding. If repairs are to be made to the CO₂ system, stop dispensing, shut off the CO₂ supply, then relieve the system pressure before proceeding. If repairs are to be made to the refrigeration system, make sure electrical power is disconnected from the unit.

Should your unit fail to operate properly, check that there is power to the unit and that the hopper contains ice. If the unit does not dispense, check the following chart under the appropriate symptoms to aid in locating the defect.

Trouble	Probable Cause
BLOWN FUSE OR CIRCUIT BREAKER.	<ul style="list-style-type: none"> A. Short circuit in wiring. B. Defective gate solenoid. C. Defective agitator motor. D. Defective gate rectifier
GATE DOES NOT OPEN. AGITATOR DOES NOT TURN.	<ul style="list-style-type: none"> A. No power. B. Bent depressor plate (does not actuate switch). C. Defective dispensing switch.
GATE DOES NOT OPEN OR IS SLUGGISH. AGITATOR TURNS.	<ul style="list-style-type: none"> A. Defective gate solenoid. B. Excessive pressure against gate slide. C. Defective Rectifier.
ICE DISPENSES CONTINUOUSLY.	<ul style="list-style-type: none"> A. Stuck or bent depressor plate (does not release switch). B. Defective dispensing switch. C. Improper switch installation.
SLUSHY ICE. WATER IN HOPPER.	<ul style="list-style-type: none"> A. Blocked drain. B. Unit not level. C. Poor ice quality due to water quality or icemaker problems. D. Improper use of flaked ice.
BEVERAGES DO NOT DISPENSE.	<ul style="list-style-type: none"> A. No 24 volt power to faucets. B. No CO₂ pressure.
BEVERAGES TOO SWEET.	<ul style="list-style-type: none"> A. Carbonator not working. B. No CO₂ pressure in carbonator. C. Faucet brix requires adjusting.

Trouble	Probable Cause
BEVERAGE NOT SWEET ENOUGH.	<ul style="list-style-type: none"> A. Empty syrup tank. B. Faucet brix requires adjusting.
AGITATORS TURN IN OPPOSITE DIRECTIONS	<ul style="list-style-type: none"> A. This is normal and is necessary for uniform ice agitation.
ICE DOES NOT DISPENSE FROM ONE GATE ASSEMBLY	<ul style="list-style-type: none"> A. Agitators reversed B. Defective gate solenoid or rectifier C. Motors wired incorrectly

Contact your local syrup or beverage equipment distributor for additional information and troubleshooting of beverage system.

SERVICE INFORMATION
DANGER: ELECTRIC SHOCK HAZARD DISCONNECT
POWER BEFORE SERVICING UNIT.

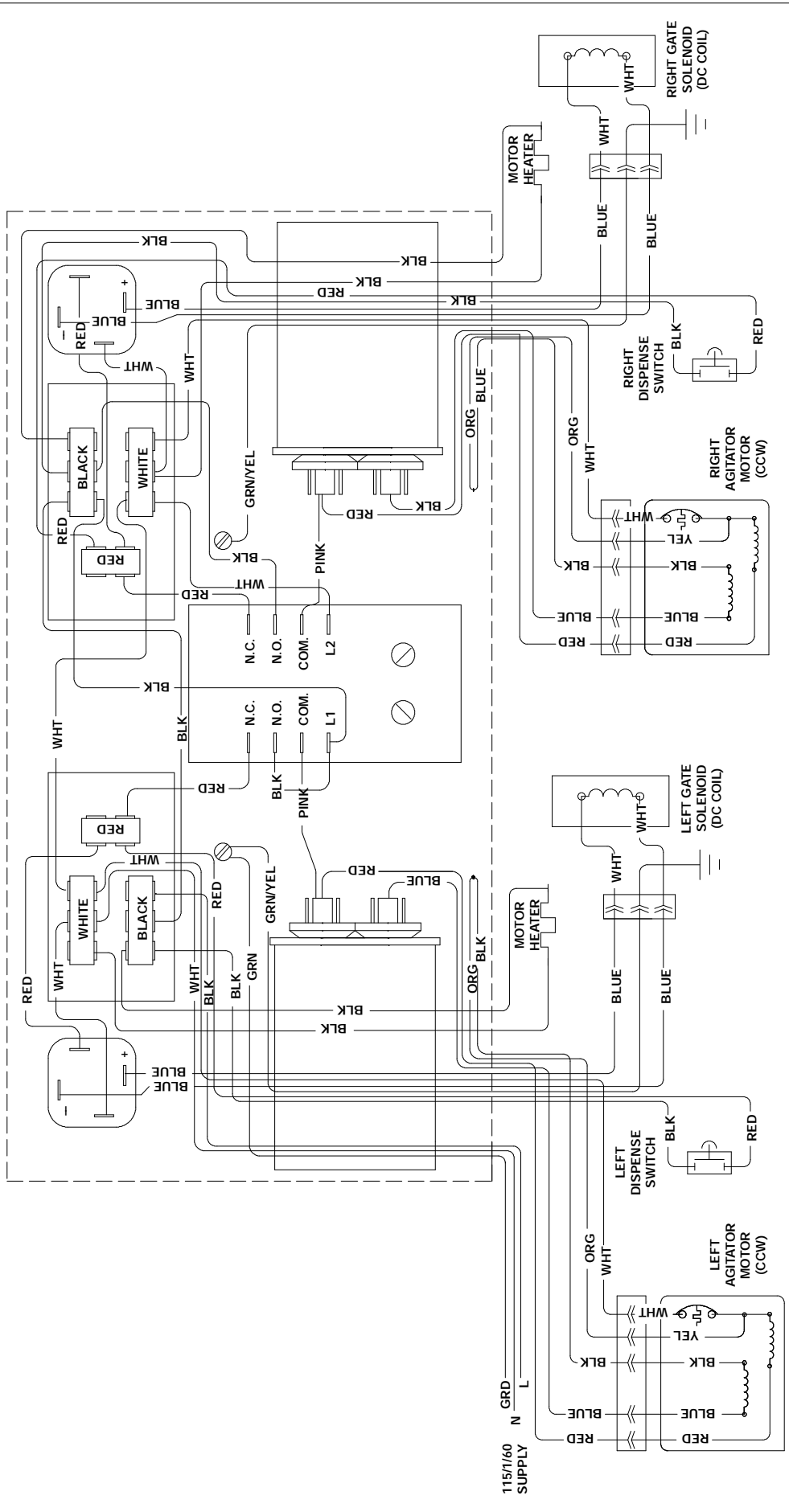

FIGURE 8. WIRING DIAGRAM

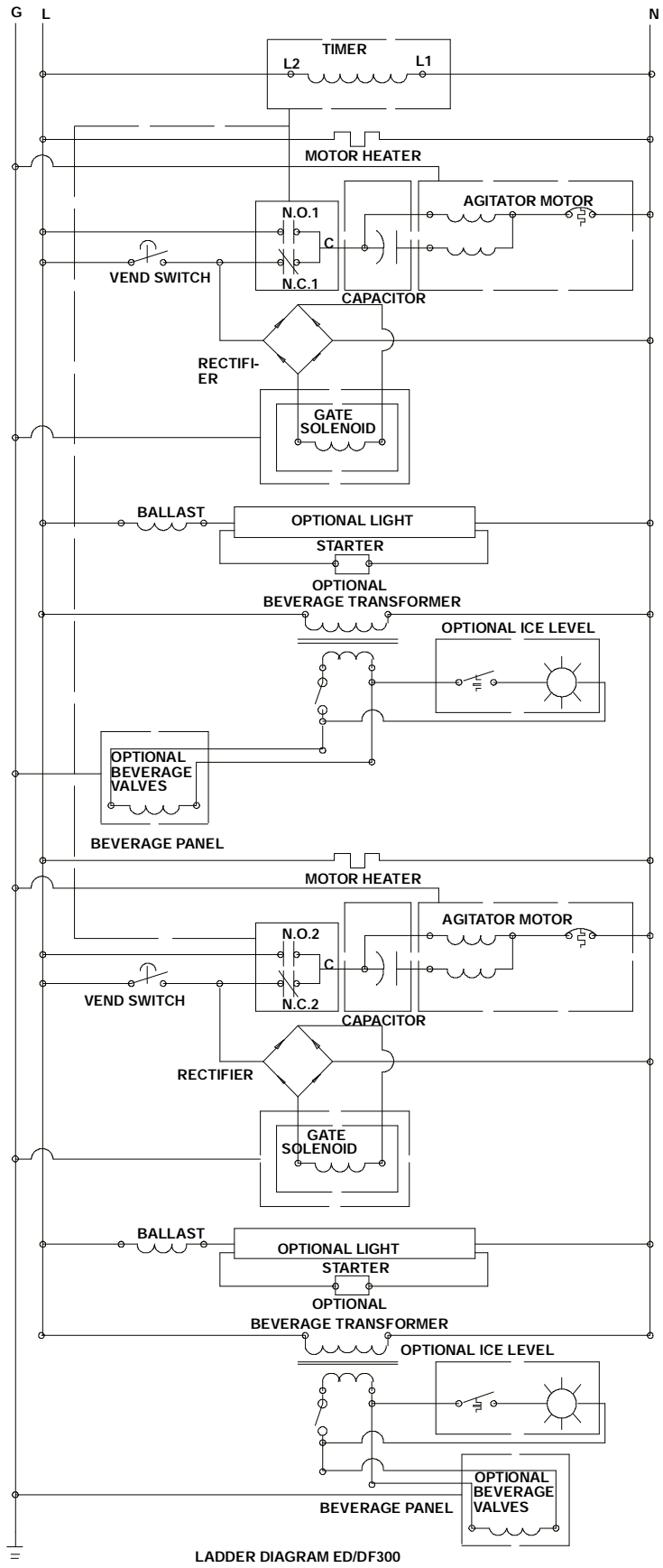

FIGURE 9. LADDER SCHEMATIC

WARRANTY

IMI Cornelius Inc. warrants that all equipment and parts are free from defects in material and workmanship under normal use and service. For a copy of the warranty applicable to your Cornelius, Remcor or Wilshire product, in your country, please write, fax or telephone the IMI Cornelius office nearest you. Please provide the equipment model number, serial number and the date of purchase.

IMI Cornelius Offices

AUSTRALIA • P.O. 210, • RIVERWOOD, • NSW 2210, AUSTRALIA • (61) 2 533 3122 • FAX (61) 2 534 2166
AUSTRIA • AM LANGEN FELDE 32 • A-1222 • VIENNA, AUSTRIA • (43) 1 233 520 • FAX (43) 1-2335-2930
BELGIUM • BOSKAPELLEI 122 • B-2930 BRAASCHAAT, BELGIUM • (32) 3 664 0552 • FAX (32) 3 665 2307
BRAZIL • RUA ITAOCARA 97 • TOMAS COELHO • RIO DE JANEIRO, BRAZIL • (55) 21 591 7150 • FAX (55) 21 593 1829
ENGLAND • TYTHING ROAD ALCESTER • WARWICKSHIRE, B49 6 EU, ENGLAND • (44) 789 763 101 • FAX (44) 789 763 644
FRANCE • 71 ROUTE DE ST. DENIS • F-95170 DEUIL LA BARRE • PARIS, FRANCE • (33) 1 34 28 6200 • FAX (33) 1 34 28 6201
GERMANY • CARL LEVERKUS STRASSE 15 • D-4018 LANGENFELD, GERMANY • (49) 2173 7930 • FAX (49) 2173 77 438
GREECE • 488 MESSOGION AVENUE • AGIA PARASKEVI • 153 42 • ATHENS, GREECE • (30) 1 600 1073 • FAX (30) 1 601 2491
HONG KONG • 1104 TAIKOTSUI CENTRE • 11-15 KOK CHEUNG ST • TAIKOKTSUE, HONG KONG • (852) 789 9882 • FAX (852) 391 6222
ITALY • VIA PELLIZZARI 11 • I-20059 • VIMARCATI, ITALY • (39) 39 608 0817 • FAX (39) 39 608 0814
NEW ZEALAND • 20 LANSFORD CRES. • P.O. BOX 19-044 AVONDALE • AUCKLAND 7, NEW ZEALAND • (64) 9 8200 357 • FAX (64) 9 8200 361
SINGAPORE • 16 TUAS STREET • SINGAPORE 2263 • (65) 862 5542 • FAX (65) 862 5604
SPAIN • POLIGONO INDUSTRIAL • RIERA DEL FONOLLAR • E-08830 SANT BOI DE LLOBREGAT • BARCELONA, SPAIN • (34) 3 640 2839 • FAX (34) 3 654 3379
USA • ONE CORNELIUS PLACE • ANOKA, MINNESOTA • (612) 421-6120 • FAX (612) 422-3255

LD004
4/21/98

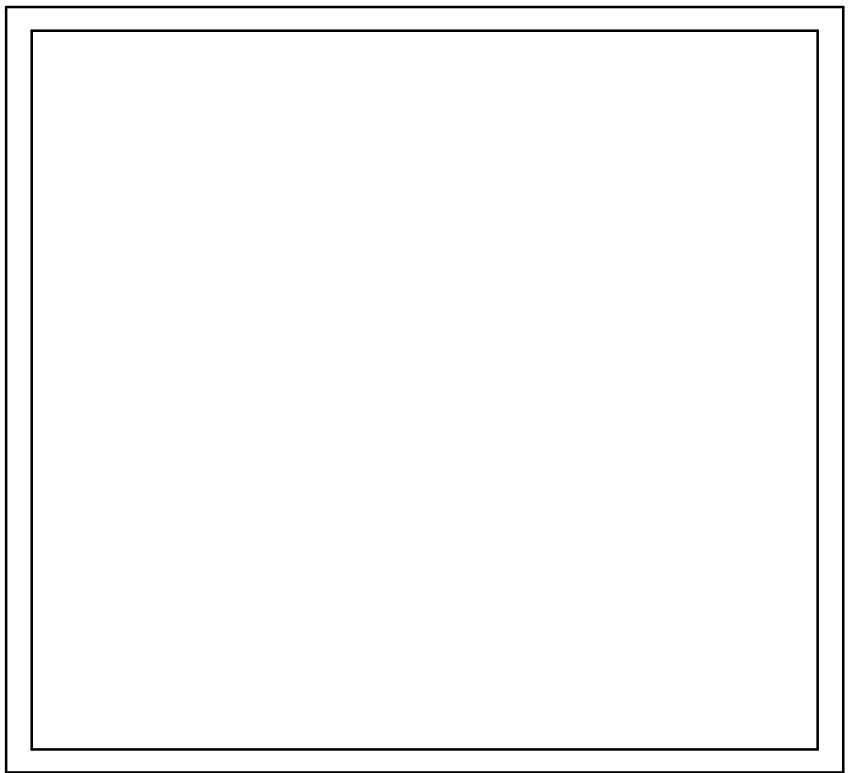

IMI CORNELIUS INC.

CORPORATE HEADQUARTERS:

One Cornelius Place
Anoka, Minnesota 55303-6234
(612) 421-6120
(800) 238-3600

