

# HF-251

Issued August 2007 • Index No. AY/5.0

## High-Frequency Arc Starter and Stabilizer

### Quick Specs

#### Industrial/Light Industrial Applications

General Manufacturing  
Tool and Die  
Repair Shops  
All-Purpose Maintenance

#### Processes

Gas Tungsten Arc  
Welding (TIG)

**Input Power** 1-Phase Power

**Rated Output** 250 A, 60% Duty Cycle

**Weight** HF-251D-1: 34 lb (15 kg)  
HF-251-2: 36 lb (16 kg)

## The Power of Blue.®

The HF-251 is compatible with power sources made by other manufacturers. For use with power sources with 14-socket receptacle (5-socket adapter available).

Increase the flexibility and performance of most AC, DC or AC/DC constant-current welding machines with these portable high-frequency arc starters and stabilizers. The unit impresses high frequency on the welding circuit and provides the arc control needed for TIG welding.

With the addition of an HF unit, your constant-current power source can handle welds on aluminum, magnesium, thin stainless steel, brass, copper and a wide variety of both ferrous and non-ferrous alloys.

Two versions (115 VAC, 50/60/100 Hz and 230 VAC, 50/60 Hz) meet most single-phase power configurations, and all are rated at 60% duty cycle.



- Power on/off switch with pilot light.
- Start, off and continuous control.
- Gas solenoid valve.
- High-frequency intensity control.
- Built-in postflow eliminates contamination.
- Protected secondary terminal.
- Convenient, portable design can be easily moved from location to location.
- 14-pin receptacle on front panel for remote controls.

## Specifications (Subject to change without notice.)

**1**  
Phase

| Model     | Input Volts           | Rated Output at 60% Duty Cycle | Dimensions   | Net Weight    |
|-----------|-----------------------|--------------------------------|--|---------------|
| HF-251D-1 | 115 VAC, 50/60/100 Hz | 250 A                          | H: 13 in (330 mm)<br>W: 9-1/4 in (235 mm)<br>D: 16 in (406 mm) | 34 lb (15 kg) |
| HF-251-2  | 230 VAC, 50/60 Hz     |                                |  | 36 lb (16 kg) |



Warranted for 1 year, parts and labor.

**MADE IN USA**  
APPLETON, WI 



**Miller Electric Mfg. Co.**  
An Illinois Tool Works Company  
1635 West Spencer Street  
Appleton, WI 54914 USA

**International Headquarters**  
Phone: 920-735-4505  
USA FAX: 920-735-4134  
Canadian FAX: 920-735-4169  
International FAX: 920-735-4125

**Web Site**  
www.MillerWelds.com



## Control Panel

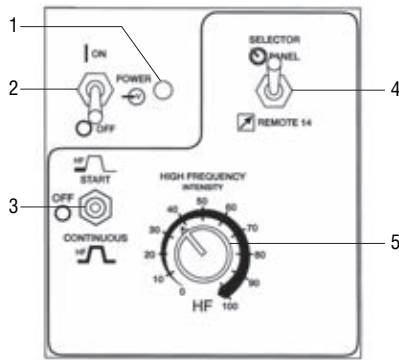

1. Pilot Light
2. Power Switch
3. High Frequency Switch
4. High Frequency Selector Switch
5. High Frequency Intensity Control

## Typical Installations

□ Denotes Plug (Threaded Collar)    □ Denotes Receptacle (External Threads)

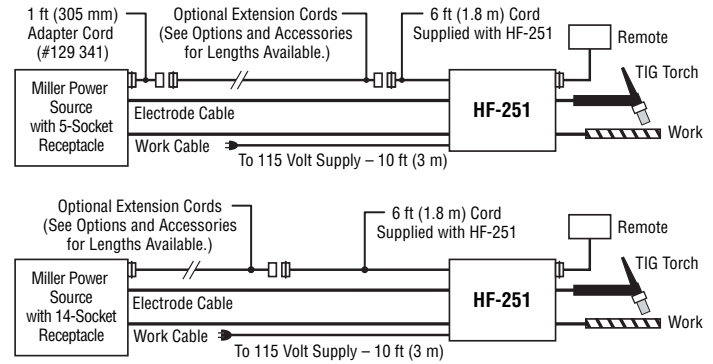

## Genuine Miller Options and Accessories



### Secondary Contactor Kit

For HF-251D-1 model  
**#041 969** Field only  
 For HF-251-2 model  
**#041 906** Field only

Mounts inside HF-251 cabinet. For use with a power source that does not have its own contactor.

### RHC-14 #129 340

Miniature remote hand current and contactor control. Includes 20 ft (6 m) cord and 14-pin plug.



### RFCS-14 #043 554

Foot pedal current and contactor control. Includes 20 ft (6 m) cord and 14-pin plug.

### Extension Cords

**#122 973** 25 ft (7.6 m)

**#122 974** 50 ft (15 m)

**#122 975** 75 ft (23 m)

Extends HF-251 farther from power source or extends remote control farther from HF-251.

### Adapter Cord #129 341

1 ft (305 mm) cord with 5-pin and 14-pin plugs for use between 5-socket receptacle power source and HF-251.

### Adapter Cord #041 947

1 ft (305 mm) cord with 14-pin plug and 5-socket receptacle for use between HF-251 and 5-pin remote controls.

## Water Coolant Systems

### Coolmate™ 3

**#043 007** 115 VAC

**#043 008** 230 VAC

Delivers cooling capacity for torches rated up to 600 A.

**Coolmate™ V3 #043 009** 115 VAC

Cools torches rated up to 500 A.

**Coolmate™ 4 #042 288** 115 VAC

Cools torches and guns rated up to 600 A.

For use with water-cooled guns. Refer to Literature Index No. AY/7.2 for additional coolant system information.

## Typical TIG (GTAW) Torches

### Air-cooled Torches

**#WP-17-25-2** (150 Amp)

**#WP-26-25-2** (200 Amp)

**Water-cooled Torches (Requires 45VII Adapter)**

**#WP-18-25-R** (350 Amp)

**#WP-20-25-R** (250 Amp)

## Ordering Information

| Power Source and Options | Stock No.                          | Description   | Qty. | Price |
|--------------------------|------------------------------------|---|------|-------|
| HF-251D-1                | <b>#042 388</b>                    | 115 V, 50/60/100 Hz   |      |       |
| HF-251-2                 | <b>#042 387</b>                    | 230 V, 50/60 Hz   |      |       |
| Secondary Contactor Kit  | <b>#041 969</b><br><b>#041 906</b> | For HF-251D-1 model. Field only<br>For HF-251-2 model. Field only |      |       |

Date:

Total Quoted Price:



Distributed by: