

WOODS

211716 LOADER MOUNTING KIT

for 1009, 1012, LC96, LC102 Loaders

on John Deere® FWA, ROPS Tractors

3120, 3320, 3520, 3720

& 3203

Includes Hose Kit

1019027

MAN0426

(Rev. 9/29/2011)

**SAVE THIS
MANUAL!**

Include it with
your Loader Manual.
It contains safety,
operation, and repair
part information
not found in other
manuals.

WOODS®

Tested. Proven. Unbeatable.

INSTALLATION MANUAL

TO THE DEALER:

Assembly and proper installation of this product is the responsibility of the Woods® dealer. Read manual instructions and safety rules. Make sure all items on the Dealer's Pre-Delivery and Delivery Check Lists in the Loader Operator's Manual are completed before releasing equipment to the owner.

TO THE OWNER:

Read this manual and Loader Operator's Manual before operating your Woods equipment. The information presented will prepare you to do a better and safer job. Keep this manual handy for ready reference. Require all operators to read this manual carefully and become acquainted with all adjustment and operating procedures before attempting to operate. Replacement manuals can be obtained from your dealer. To locate your nearest dealer, check the Dealer Locator at www.WoodsEquipment.com, or in the United States and Canada call 1-800-319-6637.

The equipment you have purchased has been carefully engineered and manufactured to provide dependable and satisfactory use. Like all mechanical products, it will require cleaning and upkeep. Lubricate the unit as specified. Observe all safety information in this manual and safety decals on the equipment.

For service, your authorized Woods dealer has trained mechanics, genuine Woods service parts, and the necessary tools and equipment to handle all your needs.

Use only genuine Woods service parts. Substitute parts will void the warranty and may not meet standards required for safe and satisfactory operation. Record the model number of your equipment in the space provided.

Model: _____

Date of Purchase: _____

Provide this information to your dealer to obtain correct repair parts.

Throughout this manual, the term **NOTICE** is used to indicate that failure to observe can cause damage to equipment. The terms **CAUTION**, **WARNING**, and **DANGER** are used in conjunction with the Safety-Alert Symbol (a triangle with an exclamation mark) to indicate the degree of hazard for items of personal safety.



This is the safety alert symbol. It is used to alert you to potential personal injury hazards. Obey all safety messages that follow this symbol to avoid possible injury or death.



Indicates a hazardous situation which, if not avoided, will result in death or serious injury.



Indicates a hazardous situation which, if not avoided, could result in death or serious injury.



Indicates a hazardous situation which, if not avoided, could result in minor or moderate injury.

**IMPORTANT
or NOTICE**

Is used to address practices not related to personal injury.

NOTE

Indicates helpful information.

WOODS®

ALITEC™
BMP®
CENTRAL FABRICATORS®
GANNON®
GILL®
WAIN-ROY®
WOODS®

2 Introduction

LMK (Rev. 7/20/2007)



SAFETY RULES

ATTENTION! BECOME ALERT! YOUR SAFETY IS INVOLVED!



¡LEA EL INSTRUCTIVO!

Si no lee Ingles, pida ayuda a alguien que si lo lea para que le traduzca las medidas de seguridad.

Safety is a primary concern in the design and manufacture of our products. Unfortunately, our efforts to provide safe equipment can be wiped out by an operator's single careless act.

In addition to the design and configuration of equipment, hazard control and accident prevention are dependent upon the awareness, concern, judgement, and proper training of personnel involved in the operation, transport, maintenance, and storage of equipment.

It has been said, "The best safety device is an informed, careful operator." We ask you to be that kind of operator.

INSTALLATION

- This Loader Mounting Kit is to be used only for the loaders and tractors specified in this manual. Any other use or modification of this mounting kit may result in serious injury or death.
- Hydraulics must be connected as instructed in this manual. Do not substitute parts, modify, or connect in any other way.
- After connecting hoses, check that all control lever positions function as instructed in the Operator's Manual. Do not put into service until control lever and equipment movements are correct.
- Safety instructions are important! Read all attachment and power unit manuals; follow all safety rules and safety decal information. (Replacement manuals and safety decals are available from your dealer. To locate your nearest dealer, check the Dealer Locator at www.WoodsEquipment.com, or in the United States and Canada call 1-800-319-6637.) Failure to follow instructions or safety rules can result in serious injury or death.
- Keep hands and body away from pressurized lines. Use paper or cardboard, not hands or other body parts to check for leaks. Wear safety goggles. Hydraulic fluid under pressure can easily penetrate skin and will cause serious injury or death.

- Make sure that all operating and service personnel know that if hydraulic fluid penetrates skin, it must be surgically removed as soon as possible by a doctor familiar with this form of injury or gangrene, serious injury, or death will result. **CONTACT A PHYSICIAN IMMEDIATELY IF FLUID ENTERS SKIN OR EYES. DO NOT DELAY.**

- Check that all hardware is properly installed. Always tighten to torque chart specifications unless instructed otherwise in this manual.

- Air in hydraulic systems can cause erratic operation and allows loads or equipment components to drop unexpectedly. When connecting equipment or hoses or performing any hydraulic maintenance, purge any air in hydraulic system by operating all hydraulic functions several times. Do this before putting into service or allowing anyone to approach the equipment.

- Protective hose sleeves must cover all hydraulic hoses within 20 inches of the operator and be secured onto metal hose fittings. Replace hoses or sleeves if damaged or if protective sleeve cannot be properly positioned or secured.

- Make sure all hydraulic hoses, fittings, and valves are in good condition and not leaking before starting power unit or using equipment. Check and route hoses carefully to prevent damage. Hoses must not be twisted, bent sharply, kinked, frayed, pinched, or come into contact with any moving parts. Operate moveable components through full operational range to check clearances. Replace any damaged hoses immediately.

- Always wear relatively tight and belted clothing to avoid getting caught in moving parts. Wear sturdy, rough-soled work shoes and protective equipment for eyes, hair, hands, hearing, and head; and respirator or filter mask where appropriate.

- Do not modify or alter or permit anyone else to modify or alter the equipment or any of its components in any way.

- Do not allow bystanders in the area when operating, attaching, removing, assembling, or servicing equipment.

- Use a suitable lifting device of sufficient capacity. Use adequate personnel to handle heavy components.

- Keep all persons away from operator control area while performing adjustments, service, or maintenance.

211716 LOADER MOUNTING KIT

Tractor Preparation

WARNING

■ Only use 211716 Loader Mounting Kit for mounting Woods 1009, 1012, LC96 and LC102 loaders on John Deere® 3120, 3320, 3520, 3720 & 3203 FWA ROPS tractors. Any other use or modification of this mounting kit may result in serious injury or death.

IMPORTANT

■ This equipment must be assembled and installed on the customer's tractor by the Woods dealer. Dealer must thoroughly inspect equipment and complete each item on the PRE-DELIVERY CHECK LIST, DELIVERY CHECK LIST, and PRODUCT REGISTRATION before equipment is released to the customer.

■ Clean threaded holes in the tractor chassis thoroughly, using a tap of the proper size. Paint, rust or debris in the threads may not permit cap screws to be installed and tightened correctly.

For installing this mounting kit, references to right, left, forward, and rearward directions are determined from the operator's position in the tractor seat.

Leave all hardware loose until loader mount is completely assembled. When assembly is completed, torque hardware to specifications listed on page 7 of this manual.

1. Shut off engine and set parking brake during installation.
2. Remove the tractor front weights and front weight bracket, if equipped.
3. The tractor must be equipped with single multi-function control lever (joystick) and hydraulic couplers, available through John Deere.
4. Larger tires may require steering stop adjustment. Tires must clear loader and loader mounts at full oscillation and full turn. See your tractor operator's manual for instructions on steering stop adjustment.

Remove Hydraulic Coupler Bracket

1. Locate tractor female hydraulic couplers located in front of the right operator platform.
2. Disconnect hydraulic couplers from hydraulic lines. Identify the lines with a color code so that they can be reinstalled in the same location.
3. Remove snap rings on back side of coupler bracket and remove hydraulic couplers from coupler bracket.
4. Remove two cap screws from tractor housing and remove coupler bracket shown in Figure 1.

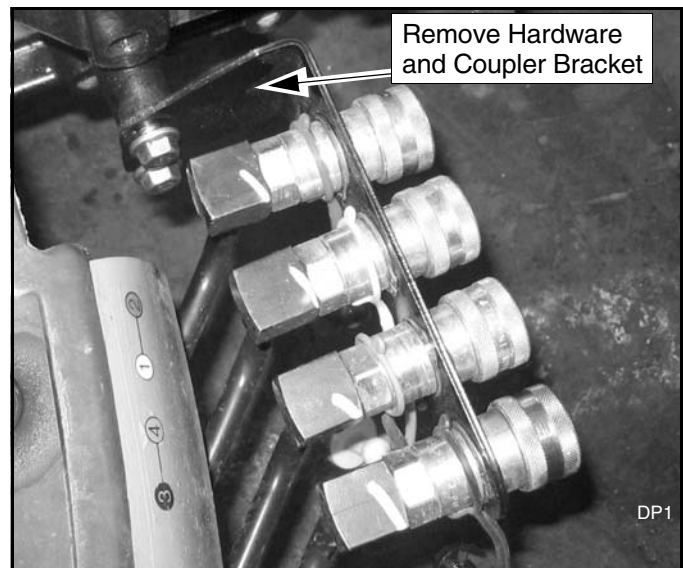

Figure 1. Remove Hydraulic Coupler Bracket

4 Mount Installation

(Rev. 9/29/2011)
MAN0426 (3/3/2006)

Install Coupler and Hose Line Brackets

1. Insert hydraulic couplers through new coupler bracket (2) and secure with snap rings.

NOTE: Make sure hydraulic couplers are in the same color sequence as they were when they were removed.

2. Connect couplers to the hydraulic feed lines.
3. Attach coupler bracket to tractor chassis using hardware previously removed.

2. 1019032 Bracket, hydraulic coupler

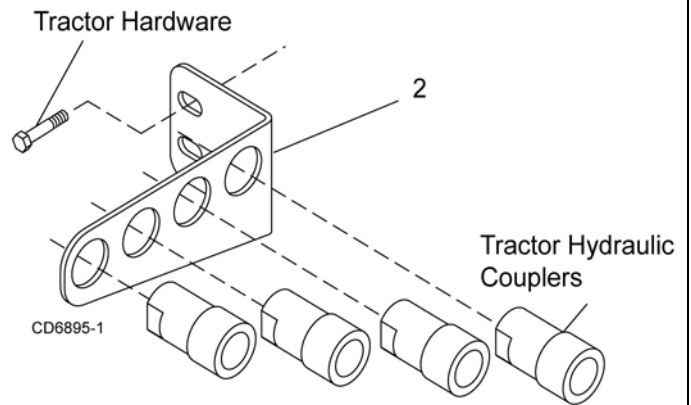

Figure 2. Hydraulic Coupler Bracket Installed

Install Right and Left Rear Mounts

1. Attach right rear mount (1) to tractor housing using four cap screws (12) and hardened flat washers (11).
2. Repeat process for installation of left mount (2).

1. 1019010 Right rear mount
2. 1019011 Left rear mount
11. 57817 5/8 Hardened flat washer
12. 64062 M16 x 2.0P x 40 mm HHCS

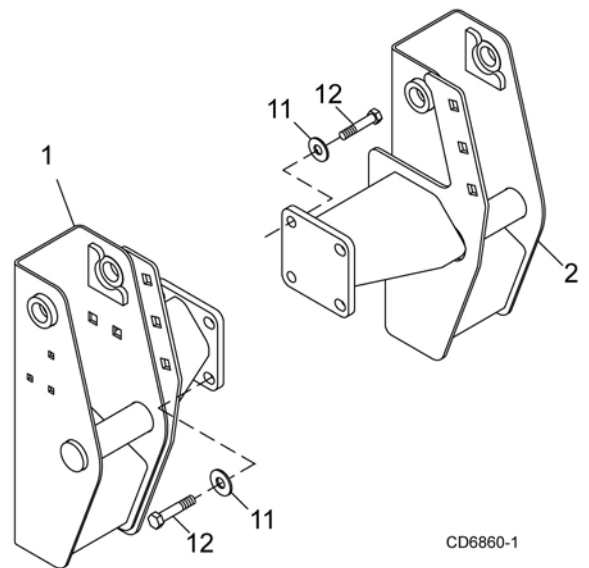

Figure 3. Rear Mount Installation

Install Right and Left Front Mounts

1. Install right (4) and left front mounts (5) to front of tractor using eight (four per side) cap screws (7), flat washers (10), and hex nuts (8).
2. Position cap screws on the outside of mount with flat washers and hex nuts on the inside of tractor frame.

4. 1034180 Right front mount
5. 1034181 Left front mount
7. 307301 M12 x 1.75P x 40 mm HHCS
8. 307813 M12 x 1.75 Hex nut
10. 57816 1/2 Hardened flat washer

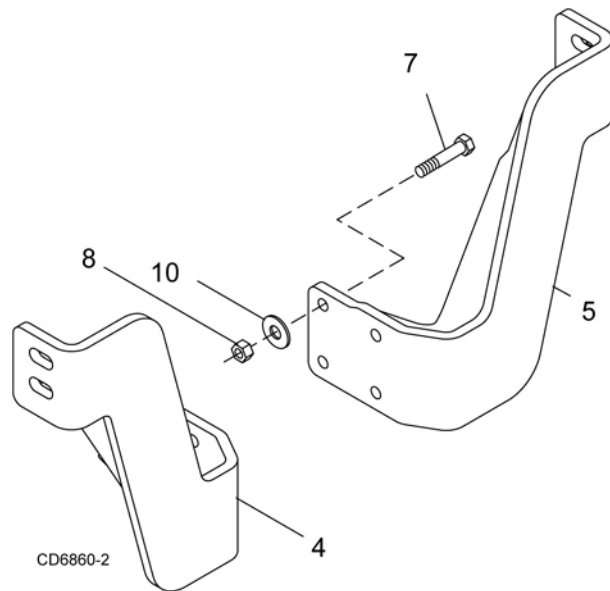

Figure 4. Front Mount Installation

Install Side Rails

1. Attach front end of right side rail (3) to outside of front mount (4).
2. Secure with two carriage bolts (9), flat washers (11), and hex nuts (6).
3. Attach side rails to the inside (between tractor and mount) of right rear mount (1) using three carriage bolts (9), flat washers (11), and hex nuts (6).
4. Repeat steps for installation of left side rail.

1. 1019010 Right rear mount
3. 1019013 Side rail
4. 1019018 Right front mount
6. 230 5/8 Hex nut
9. 5607 5/8 NC x 1-1/2 Carriage bolt
11. 57817 5/8 Hardened flat washer

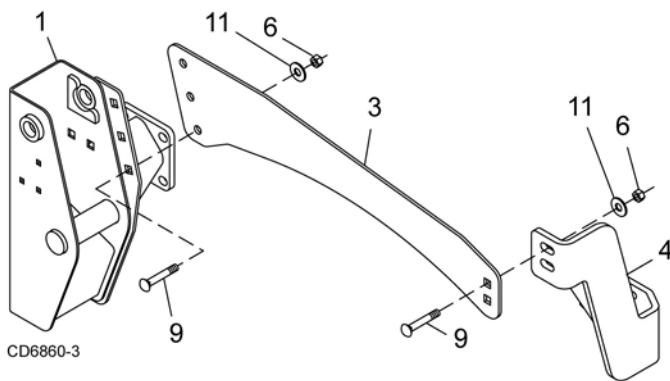

Figure 5. Right Side Rail Installation



Figure 6. Left Side Rail Installed

6 Mount Installation

(Rev. 9/29/2011)
MAN0426 (3/3/2006)

Torque Hardware

Torque all mounting hardware to specifications given below.

TORQUE SPECIFICATIONS				
Ref	Cap Screw	Qty	Wrench Size	Required Torque
7	M12 x 1.75P x 40 mm	8	18 mm	50 lbs-ft. (68 N-m)
9	5/8 NC x 1-1/2 Carriage bolt GR5	10	15/16	170 lbs-ft. (230 N-m)
12	M16 x 2.0P x 40 mm	8	24 mm	125 lbs-ft. (169 N-m)

Install Grill Guard (Optional)

1. Align grill guard (A) with holes on front of tractor frame and secure into position using four cap screws (B), hardened flat washers (D), and hex nuts (C).
2. Torque to 50 lbs-ft.

- A. 1019012 Grill guard -
(Includes hardware B, C & D)
- B. 307301 M12 x 1.75P x 40 mm HHCS
- C. 307813 M12 x 1.75 Hex nut
- D. 57816 1/2 Hardened flat washer

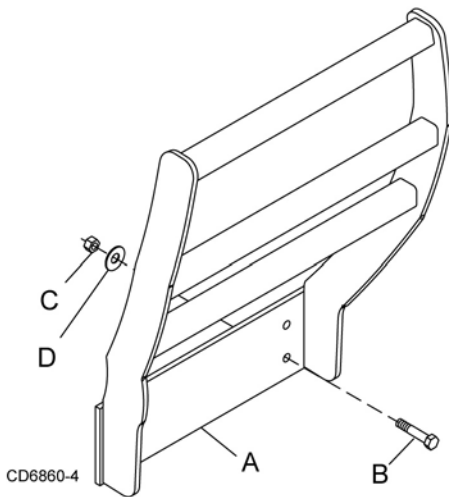

Figure 7. Grill Guard Installation



Figure 8. Grill Guard Installed

As a valued customer, Woods appreciates your comments. Once loader mount and hydraulic hoses have been installed, please take a few minutes to complete the Loader Mount Evaluation sheet that was supplied with this mount. Your comments will help us continue to bring you quality products.

1019027 HOSE KIT INSTALLATION

General Description

These instructions are for operating the loader using the tractor hydraulic remote control lever. To use this hydraulic connection, the tractor must be equipped with the manufacturer's multi-function hydraulic lever and four tractor hydraulic couplers.

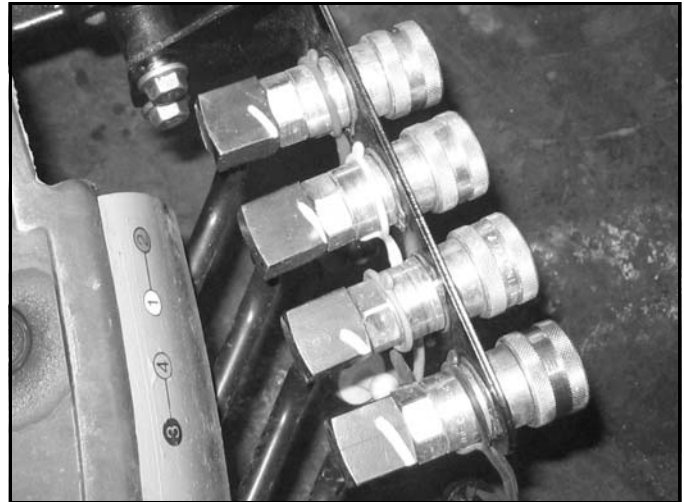

Figure 9. Tractor Remote Control Connections

Assemble Hoses

Attach 45-degree elbow (3) and male quick coupler (8) to the end of the four loader supply hoses (1). See Figure 10.

1. 1018142 Hose, 46" x 3/8 NPTM x 3/4 JICM
3. 313015 Elbow, 3/8 NPTM x 3/8 NPTF 45°
8. 64300 Quick coupler, male 3/8

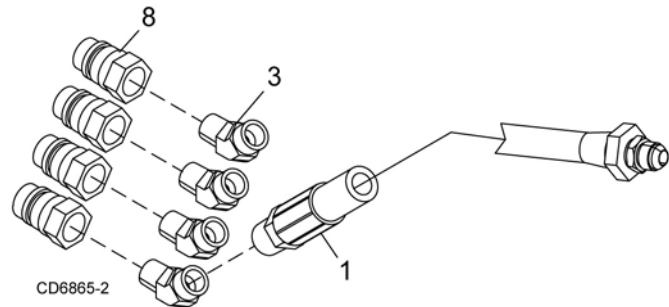

Figure 10. Hose Kit Assembly

Connect Hoses to Loader

1. Connect the loader supply hoses to loader steel feedlines.
2. Follow color code listed in Figure 11.

- A - BUCKET CYL. BASE END (DUMP) - RED
- B - BUCKET CYL. ROD END (ROLLBACK) - BLUE
- C - BOOM CYL. ROD END (DOWN) - YELLOW
- D - BOOM CYL. BASE END (UP - GREEN)

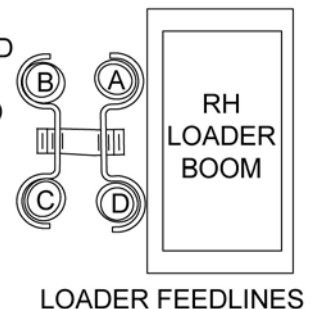

Figure 11. Loader Feedline Identification

Connect Hoses to Tractor

1. Connect hydraulic hoses to tractor hydraulic couplers as shown in Figure 12.
2. Attach color coded plastic bands around male quick couplers to identify quick coupler connections.

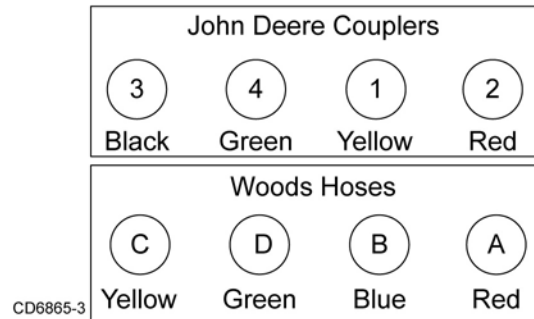
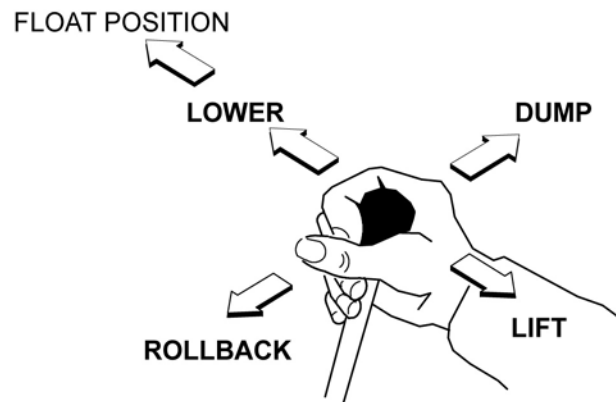

Figure 12. Hydraulic Hose Connection

Verification of Control Movements

1. **Mount loader to tractor:** Remove mount pins from loader uprights. Align tractor with loader and slowly drive tractor into loader. Shut off tractor.
2. Connect loader feedline hoses to tractor hydraulic remote control hydraulic couplers. See Figure 12 for hose connections.
3. Mount loader to tractor by activating bucket cylinders to raise or lower the loader uprights into the loader mounts. Slowly drive tractor forward, activating appropriate cylinders to engage loader completely into mounts. Insert mounting pins to secure loader.
4. Comply with all Safety Rules and start the tractor.
5. Check that all hydraulic control lever positions operate the loader movements correctly as shown in Figure 13.
6. If loader movements do not respond correctly, shut off tractor, relieve pressure, and reconnect properly. Loader control movements must be correct before proceeding.
7. Once all loader functions are correct, start the tractor and operate the loader to check for leaks. Purge any remaining air from the hydraulic system and check oil level.
8. When hose routings and correct loader operations are verified, place a matching colored band around male and female quick-disconnect couplers. The colored bands will make re-installation easier when the loader is removed from the tractor.
9. Be sure that adequate slack is left in the hoses so they can move as the loader moves through its full range of motion.
10. Before operating the loader, make sure that the Pre-Delivery, Delivery, and Pre-Operation Check Lists from the Loader Operator's Manual have been completed.



- Handle Forward - Boom down
- Handle forward to limit - Float position
- Handle back - Boom up
- Handle to right - Dump bucket or attachment
- Handle to left - Rollback bucket or attachment

Figure 13. Single Lever Control Operation

211716 LOADER MOUNTING KIT

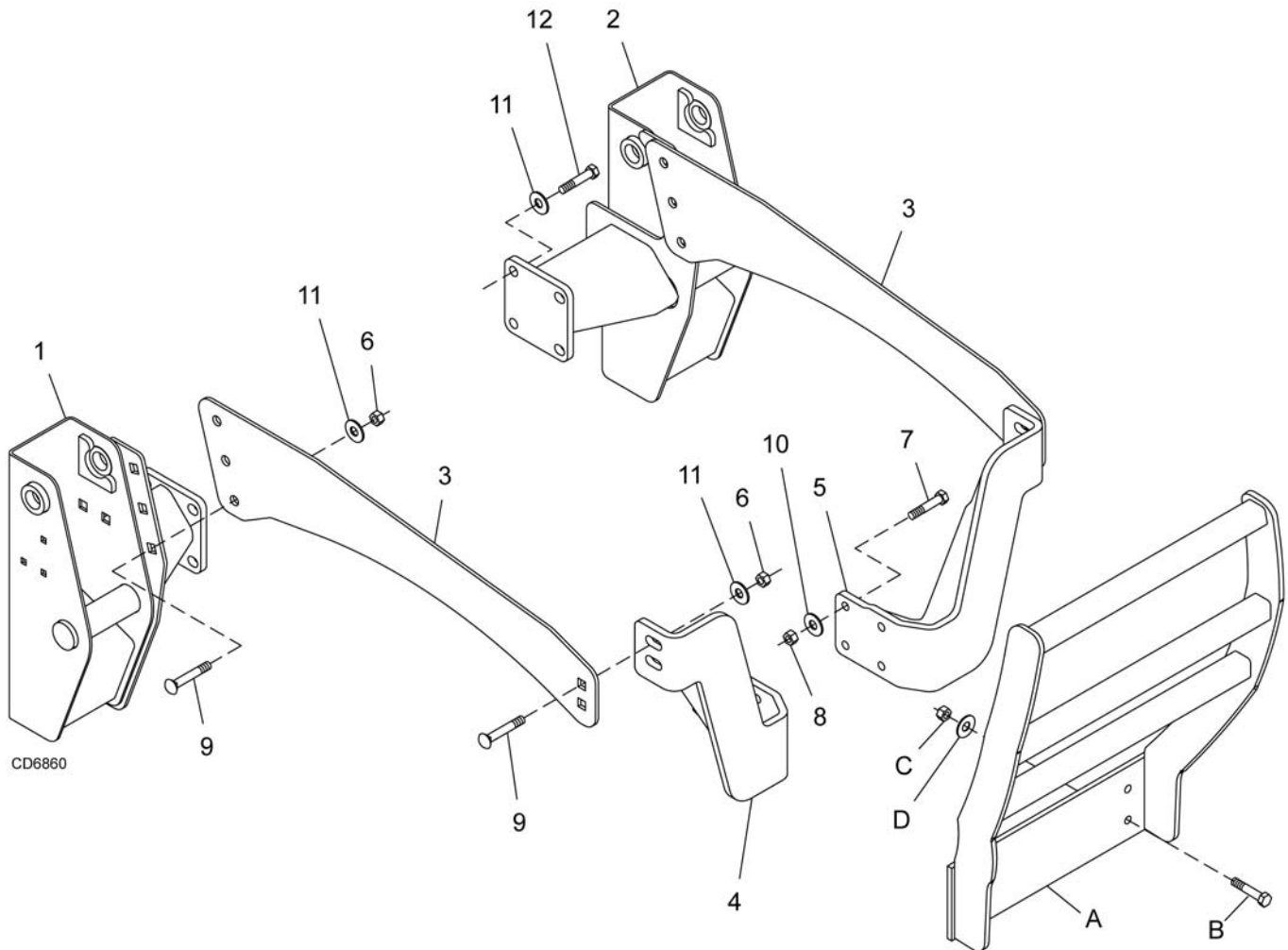

1019012 Grill Guard (Optional)

REF	PART	QTY	DESCRIPTION
1	1019010	1	Right rear mount
2	1019011	1	Left rear mount
3	1019013	2	Side rail
4	1034180	1	Right front mount
5	1034181	1	Left front mount
6	230 *	10	5/8 NC Hex nut
7	307301	8	M12 x 1.75P x 40 mm HHCS
8	307813	8	M12 x 1.75P Hex nut
9	5607 *	10	5/8 NC x 1-1/2 Carriage bolt
10	57816	8	1/2 Hardened flat washer
11	57817	18	5/8 Hardened flat washer
12	64062	8	M16 x 2.0P x 40 mm Cap screw

REF	PART	QTY	DESCRIPTION
A	1019012	1	Grill guard, includes items B - D
B	307301	4	M12 x 1.75P x 40 mm HHCS
C	307813	4	M12 x 1.75P Hex nut
D	57816	4	1/2 Hardened flat washer

* Standard hardware, obtain locally

10 Parts

(Rev. 9/29/2011)
MAN0426 (3/3/2006)

1019027 HOSE KIT

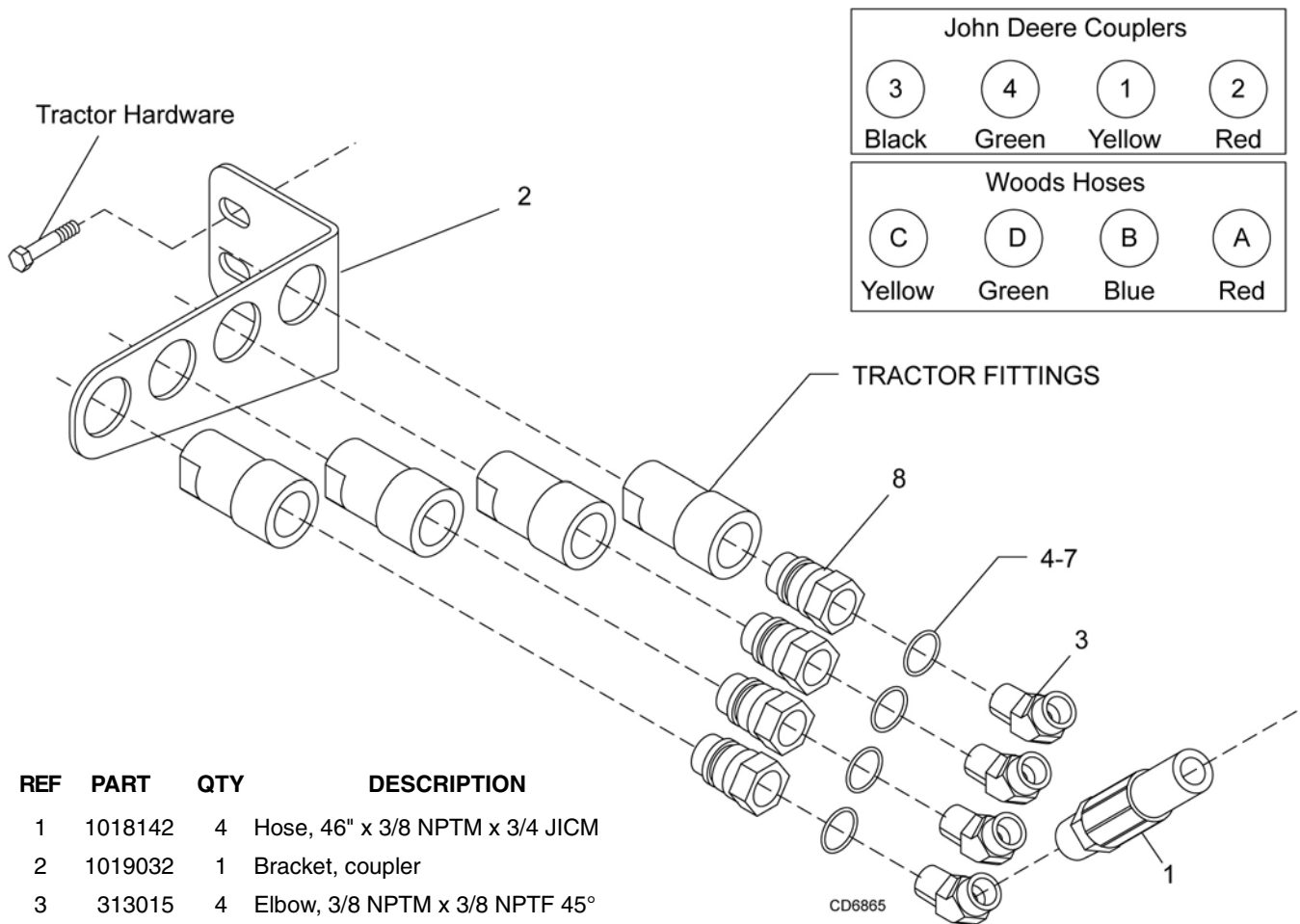

REF	PART	QTY	DESCRIPTION
1	1018142	4	Hose, 46" x 3/8 NPTM x 3/4 JICM
2	1019032	1	Bracket, coupler
3	313015	4	Elbow, 3/8 NPTM x 3/8 NPTF 45°
4	395061	2	Plastic spiral band, red
5	395062	2	Plastic spiral band, blue
6	56061	2	Plastic spiral band, green
7	56062	2	Plastic spiral band, yellow
8	64300	4	Quick coupler, male 3/8
NS	88 *	AR	Plastic tie

* Standard hardware, obtain locally
 NS Not shown
 AR As required

BOLT TORQUE CHART

Always tighten hardware to these values unless a different torque value or tightening procedure is listed for a specific application.

Fasteners must always be replaced with the same grade as specified in the manual parts list.

Always use the proper tool for tightening hardware: SAE for SAE hardware and Metric for metric hardware.

Make sure fastener threads are clean and you start thread engagement properly.

All torque values are given to specifications used on hardware defined by SAE J1701 MAR 99 & J1701M JUL 96.

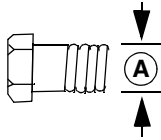

SAE SERIES TORQUE CHART



SAE Grade 2
(No Dashes)

SAE Bolt Head
Identification



SAE Grade 5
(3 Radial Dashes)



SAE Grade 8
(6 Radial Dashes)

Ⓐ Diameter (Inches)	Wrench Size	MARKING ON HEAD					
		SAE 2		SAE 5		SAE 8	
		lbs-ft	N-m	lbs-ft	N-m	lbs-ft	N-m
1/4"	7/16"	6	8	10	13	14	18
5/16"	1/2"	12	17	19	26	27	37
3/8"	9/16"	23	31	35	47	49	67
7/16"	5/8"	36	48	55	75	78	106
1/2"	3/4"	55	75	85	115	120	163
9/16"	13/16"	78	106	121	164	171	232
5/8"	15/16"	110	149	170	230	240	325
3/4"	1-1/8"	192	261	297	403	420	569
7/8"	1-5/16"	306	416	474	642	669	907
1"	1-1/2"	467	634	722	979	1020	1383

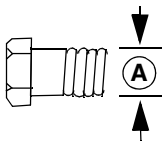

METRIC SERIES TORQUE CHART



Metric
Grade 8.8

Metric Bolt Head
Identification



Metric
Grade 10.9

Ⓐ Diameter & Thread Pitch (Millimeters)	Wrench Size	COARSE THREAD				FINE THREAD				Ⓐ Diameter & Thread Pitch (Millimeters)
		MARKING ON HEAD				MARKING ON HEAD				
		Metric 8.8		Metric 10.9		Metric 8.8		Metric 10.9		
		N-m	lbs-ft	N-m	lbs-ft	N-m	lbs-ft	N-m	lbs-ft	
6 x 1.0	10 mm	8	6	11	8	8	6	11	8	6 x 1.0
8 x 1.25	13 mm	20	15	27	20	21	16	29	22	8 x 1.0
10 x 1.5	16 mm	39	29	54	40	41	30	57	42	10 x 1.25
12 x 1.75	18 mm	68	50	94	70	75	55	103	76	12 x 1.25
14 x 2.0	21 mm	109	80	151	111	118	87	163	120	14 x 1.5
16 x 2.0	24 mm	169	125	234	173	181	133	250	184	16 x 1.5
18 x 2.5	27 mm	234	172	323	239	263	194	363	268	18 x 1.5
20 x 2.5	30 mm	330	244	457	337	367	270	507	374	20 x 1.5
22 x 2.5	34 mm	451	332	623	460	495	365	684	505	22 x 1.5
24 x 3.0	36 mm	571	421	790	583	623	459	861	635	24 x 2.0
30 x 3.0	46 mm	1175	867	1626	1199	1258	928	1740	1283	30 x 2.0

Typical Washer Installations

8/9/00

BOLT SIZE CHART

NOTE: Chart shows bolt thread sizes and corresponding head (wrench) sizes for standard SAE and metric bolts.

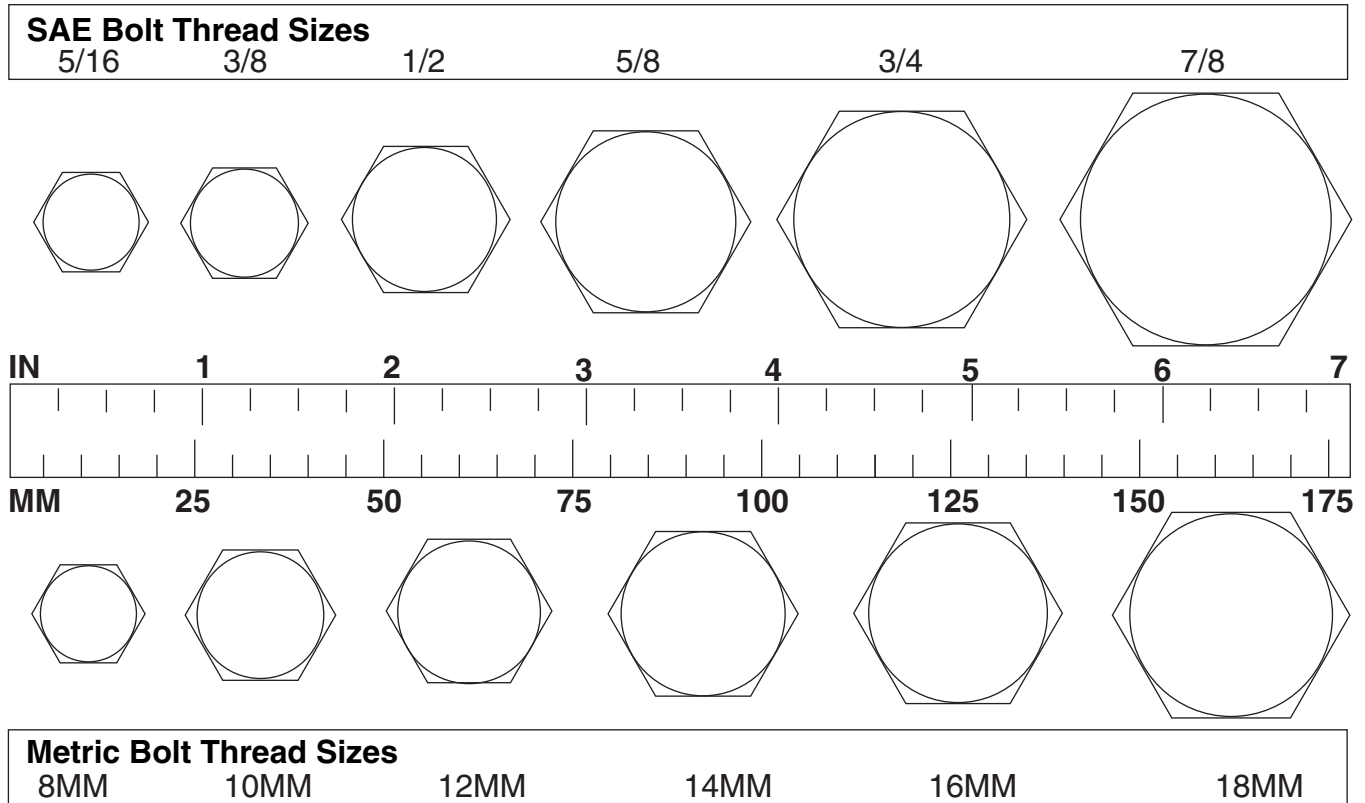

ABBREVIATIONS

AG Agriculture
 ATF Automatic Transmission Fluid
 BSPP British Standard Pipe Parallel
 BSPTM British Standard Pipe Tapered Male
 CV Constant Velocity
 CCW Counter-Clockwise
 CW Clockwise
 F Female
 GA Gauge
 GR (5, etc.) Grade (5, etc.)
 HHCS Hex Head Cap Screw
 HT Heat-Treated
 JIC Joint Industry Council 37° Degree Flare
 LH Left Hand
 LT Left
 m Meter
 mm Millimeter
 M Male
 MPa Mega Pascal
 N Newton

NC National Coarse
 NF National Fine
 NPSM National Pipe Straight Mechanical
 NPT National Pipe Tapered
 NPT SWF National Pipe Tapered Swivel Female
 ORBM O-Ring Boss - Male
 P Pitch
 PBY Power-Beyond
 psi Pounds per Square Inch
 PTO Power Take Off
 QD Quick Disconnect
 RH Right Hand
 ROPS Roll-Over Protective Structure
 RPM Revolutions Per Minute
 RT Right
 SAE Society of Automotive Engineers
 UNC Unified Coarse
 UNF Unified Fine
 UNS Unified Special



WARRANTY

(Replacement Parts For All Models Except Mow'n Machine™
Zero-Turn Mowers and Woods Boundary™ Utility Vehicles)

Woods Equipment Company ("WOODS") warrants this product to be free from defect in material and workmanship for a period of ninety (90) days from the date of delivery of the product to the original purchaser with the exception of V-belts, which will be free of defect in material and workmanship for a period of 12 months.

Under no circumstances will this Warranty apply in the event that the product, in the good faith opinion of WOODS, has been subjected to improper operation, improper maintenance, misuse, or an accident. This Warranty does not cover normal wear or tear, or normal maintenance items.

This Warranty is extended solely to the original purchaser of the product. Should the original purchaser sell or otherwise transfer this product to a third party, this Warranty does not transfer to the third party purchaser in any way. There are no third party beneficiaries of this Warranty.

WOODS' obligation under this Warranty is limited to, at WOODS' option, the repair or replacement, free of charge, of the product if WOODS, in its sole discretion, deems it to be defective or in noncompliance with this Warranty. **The product must be returned to WOODS with proof of purchase within thirty (30) days after such defect or noncompliance is discovered or should have been discovered, routed through the dealer and distributor from whom the purchase was made, transportation charges prepaid.** WOODS shall complete such repair or replacement within a reasonable time after WOODS receives the product. THERE ARE NO OTHER REMEDIES UNDER THIS WARRANTY. THE REMEDY OF REPAIR OR REPLACEMENT IS THE SOLE AND EXCLUSIVE REMEDY UNDER THIS WARRANTY.

THERE ARE NO WARRANTIES WHICH EXTEND BEYOND THE DESCRIPTION ON THE FACE OF THIS WARRANTY. WOODS MAKES NO OTHER WARRANTY, EXPRESS OR IMPLIED, AND WOODS SPECIFICALLY DISCLAIMS ANY IMPLIED WARRANTY OF MERCHANTABILITY AND/OR ANY IMPLIED WARRANTY OF FITNESS FOR A PARTICULAR PURPOSE.

WOODS shall not be liable for any incidental or consequential losses, damages or expenses, arising directly or indirectly from the product, whether such claim is based upon breach of contract, breach of warranty, negligence, strict liability in tort or any other legal theory. Without limiting the generality of the foregoing, Woods specifically disclaims any damages relating to (i) lost profits, business, revenues or goodwill; (ii) loss of crops; (iii) loss because of delay in harvesting; (iv) any expense or loss incurred for labor, supplies, substitute machinery or rental; or (v) any other type of damage to property or economic loss.

This Warranty is subject to any existing conditions of supply which may directly affect WOODS' ability to obtain materials or manufacture replacement parts.

No agent, representative, dealer, distributor, service person, salesperson, or employee of any company, including without limitation, WOODS, its authorized dealers, distributors, and service centers, is authorized to alter, modify, or enlarge this Warranty.

Answers to any questions regarding warranty service and locations may be obtained by contacting:

ALITEC™
BMP®
CENTRAL FABRICATORS®
GANNON®
GILL®
WAIN-ROY®
WOODS®

WOODS®

**Woods Equipment
Company**

2606 South Illinois Route 2
Post Office Box 1000
Oregon IL 61061

800-319-6637 tel
800-399-6637 fax
www.WoodsEquipment.com



WARRANTY

All Models Except Mow'n Machine™ Zero-Turn Mowers

Please Enter Information Below and Save for Future Reference.

Date Purchased: _____ From (Dealer): _____

Model Number: _____ Serial Number: _____

Woods Equipment Company ("WOODS") warrants this product to be free from defect in material and workmanship. Except as otherwise set forth below, the duration of this Warranty shall be for TWELVE (12) MONTHS COMMENCING ON THE DATE OF DELIVERY OF THE PRODUCT TO THE ORIGINAL PURCHASER.

All current model loaders and backhoes are warranted for two (2) years from the date of delivery to the original purchaser.

The warranty periods for specific parts or conditions are listed below:

Part or Condition Warranted	Model Number	Duration (from date of delivery to the original purchaser)
Gearbox Seals	All units listed below	2 years
Gearbox components	BW1260, BW1620, BW1800, BW2400	8 years
	BW240HD, BW180HD, BW180HB, BW126HB	7 years
	BB48X, BB60X, BB72X, BB84X, BB600X, BB720X, BB840X, BB6000X, BB7200X, BB8400X, DS1260, DSO1260, DS1440, TS1680, BW126-3, BW180-3, BW240	6 years
	PHD25, PHD35, PHD65, PHD95, 2162, 3240, DS96, DS120, RCC42, RM550-2, RM660-2, RD990X, PRD6000, PRD7200, PRD8400, S15CD, S20CD, S22CD, S25CD, S27CD, BW180LH, TC/R74, TC/R68, TC/R60, TBW144, TBW180, TBW204	5 years
	RDC54, RD60, RD72, TBW150C, TS/R60, TS/R52, TS/R44	3 years (1 year if used in rental or commercial applications)
Blade spindles	RM550-2, RM660-2, RD990X, PRD6000, PRD7200, PRD8400, TBW144, TBW180, TBW204	3 years
Rust-through	BB600, BB720, BB840, BB6000, BB7200, BB8400, BW126-3, BW126HB, BW180-3, BW180HB, BW180HD, BW1260, BW1800, BW240, BW240HD, 2162, 3240, DS1260, DSO1260, DS1440, TS1680	10 years

Under no circumstances will this Warranty apply in the event that the product, in the good faith opinion of WOODS, has been subjected to improper operation, improper maintenance, misuse, or an accident. This Warranty does not apply in the event that the product has been materially modified or repaired by someone other than WOODS, a WOODS authorized dealer or distributor, and/or a WOODS authorized service center. This Warranty does not cover normal wear or tear, or normal maintenance items. This Warranty also does not cover repairs made with parts other than those obtainable through WOODS.

This Warranty is extended solely to the original purchaser of the product. Should the original purchaser sell or otherwise transfer this product to a third party, this Warranty does not transfer to the third party purchaser in any way. There are no third party beneficiaries of this Warranty.

WOODS makes no warranty, express or implied, with respect to engines, batteries, tires or other parts or accessories not manufactured by WOODS. Warranties for these items, if any, are provided separately by their respective manufacturers.

WOODS' obligation under this Warranty is limited to, at WOODS' option, the repair or replacement, free of charge, of the product if WOODS, in its sole discretion, deems it to be defective or in noncompliance with this Warranty. **The product must be returned to WOODS with proof of purchase within thirty (30) days after such defect or noncompliance is discovered or should have been discovered, routed through the dealer and distributor from whom the purchase was made, transportation charges prepaid.** WOODS shall complete such repair or replacement within a reasonable time after WOODS receives the product. **THERE ARE NO OTHER REMEDIES UNDER THIS WARRANTY. THE REMEDY OF REPAIR OR REPLACEMENT IS THE SOLE AND EXCLUSIVE REMEDY UNDER THIS WARRANTY.**

THERE ARE NO WARRANTIES WHICH EXTEND BEYOND THE DESCRIPTION ON THE FACE OF THIS WARRANTY. WOODS MAKES NO OTHER WARRANTY, EXPRESS OR IMPLIED, AND WOODS SPECIFICALLY DISCLAIMS ANY IMPLIED WARRANTY OF MERCHANTABILITY AND/OR ANY IMPLIED WARRANTY OF FITNESS FOR A PARTICULAR PURPOSE.

WOODS shall not be liable for any incidental or consequential losses, damages or expenses, arising directly or indirectly from the product, whether such claim is based upon breach of contract, breach of warranty, negligence, strict liability in tort or any other legal theory. Without limiting the generality of the foregoing, Woods specifically disclaims any damages relating to (i) lost profits, business, revenues or goodwill; (ii) loss of crops; (iii) loss because of delay in harvesting; (iv) any expense or loss incurred for labor, supplies, substitute machinery or rental; or (v) any other type of damage to property or economic loss.

This Warranty is subject to any existing conditions of supply which may directly affect WOODS' ability to obtain materials or manufacture replacement parts.

No agent, representative, dealer, distributor, serviceperson, salesperson, or employee of any company, including without limitation, WOODS, its authorized dealers, distributors, and service centers, is authorized to alter, modify, or enlarge this

Warranty. Answers to any questions regarding warranty service and locations may be obtained by contacting: **ALITEC™**

Woods Equipment Company

2606 South Illinois Route 2
Post Office Box 1000
Oregon, Illinois 61061 USA

800-319-6637 tel
800-399-6637 fax
www.WoodsEquipment.com



BMP®
CENTRAL FABRICATORS®
GANNON®
GILL®
WAIN-ROY®
WOODS®

PART NUMBER
MAN0426

815-732-2141 tel
815-732-7580 fax
www.WoodsEquipment.com

WOODS[®]

©2006 Woods Equipment Company. All rights reserved. WOODS, the Woods logo, and "Tested. Proven. Unbeatable." are trademarks of Woods Equipment Company. All other trademarks, trade names, or service marks not owned by Woods Equipment Company that appear in this manual are the property of their respective companies or mark holders. Specifications subject to change without notice.