



User's Manual

Subwoofer **High Force 3 Ice Power**

Made in France

We thank you very much for purchasing a Waterfall High Force Subwoofer. Our deliberate choice for aesthetics and performance is constantly guiding our research and development towards innovative technologies. In order to achieve the best performance with your Home Cinema system, we recommend you read carefully the following set up instructions.

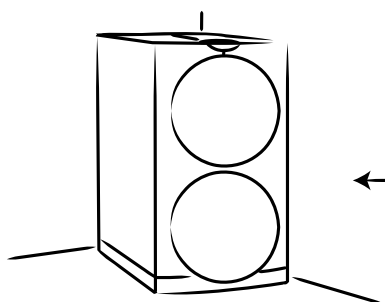

In order to achieve the best acoustical performance, the HF3 IP Evo, ideally has to be positioned near an angle/corner in the room.

A) Functions & Set up of HF3 IP's Amplifier

Warning :

Check the mains voltage selector (N°1) position (115V/230V) and use the correct voltage for your country before connecting the mains plug. Changing the fuse : In the event of complete failure, first disconnect the powers cable from the mains, then check the mains fuse. When replacing the fuse, only use a fuse which is absolutely identical to the original one. If this does not solve the problem, contact your dealer.

- Only the subwoofer is to be connected to the mains supply. Never plug your speakers directly into the main power supply.
- Before proceeding with any connection, make sure that all your equipment is switched off.
- Before switching it on, please ensure that the "level" button (N°4) is on minimum.
- Your Waterfall Speakers are to be directly connected to the speaker output socket on your amplifier or A/VProcessor.
- Also ensure that the polarities are correct : + (red) and - (black).
- Do not expose this product to heat and humidity.

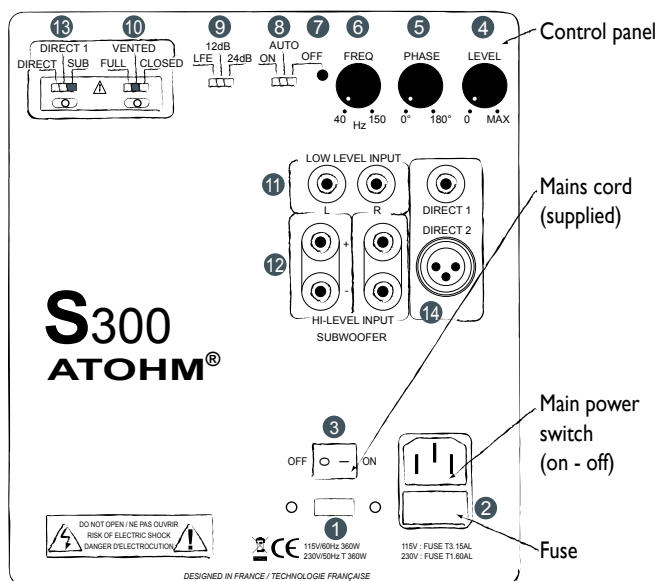

- 1 Mains voltage selector (115V/230V)
- 2 Fuse
- 3 Main power switch (on - off)
- 4 Level :Volume adjustment of the integrated amplifier.
- 5 Phase :Allows you to adjust phase from 0 to 180°.
- 6 Freq :Adjustment of the frequency cut off, from 40 to 150Hz.
- 7 PRT : Standby LED indicates unit in standby mode with power connected. When the Sub is activated this standby LED is off and the Logo LED lights up. Flashes in case of default.
- 8 On – Auto – Off : Recommended Setting should be : "Auto", so when not in use for a while, amplifier goes back into standby, if "On" position is used, this means the amplifier will continuously be on, and will not go into standby.
- 9 24-12-LFE : Switching of the active filter of the Sub. The choice of 24Db per octave or 12Db per octave is to be determined through listening and personal choice.
- 10 Factory settings. **DO NOT CHANGE.**
- 11 Low Level Input/Output :The "audio" signals are transmitted by a cinch cable (supplied by our retailer) linking the "subwoofer Pre-out" of the processor to one of the "Line in" of the Sub, (either white or red entry).
- 12 "High Level Input" :To be used only with conventional stereo amplifiers.
- 13 Input selector (for specific set up).
- 14 Connections for specific use.

The subwoofer **MUST** be connected to the mains with the enclosed connector cord. The main switch has to be on "on" position and the (N°8) switch "on-auto-off" in the "auto" position. Your HF3 IP Subwoofer is equipped with a wide range of connection options for Hi Fi or Audi Video, Home Cinema.

B) Connection of your Subwoofer and settings in Home Cinema

Your A/V amplifier is equipped with a "pre out sub". Connect it with your modulation cable (not supplied) to one of the "low level input".

I • Settings of your A/V amplifier :

In the Set up menu of your A/V amplifier, the "small" mode on speakers should be selected. If your processor gives you a choice for the frequency cut off (crossover) in the menu, then choose :

- **80Hz** for the channels using Iguasçu Evo or Victoria Evo.
- **120Hz** for the channels using Hurricane Evo or Elora.
- **150Hz** for the channels using Serio.

If your configuration is a mix of these products and if your Processor doesn't allow you to choose variable frequencies then choose 120 Hz.

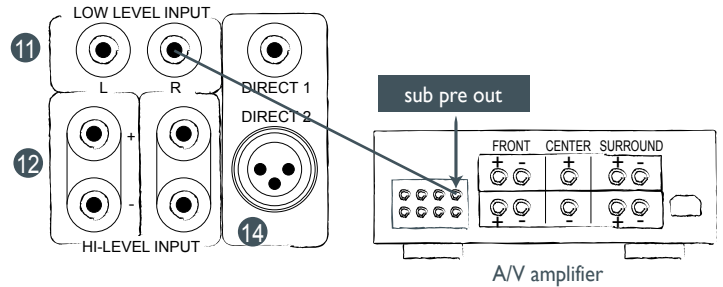

Finalise the complete set up (distance, test tone). Please refer to your A/V's user manual or dealer if you need assistance.

2 • Please set up the HF3 IP's amplifier as described below :

- Freq (N°6) on 150 Hz. The "24-12-LFE" (N°9) switch must be on the "LFE" position,
- Phase (N°5) should be on 0° in most of the cases. Adjust the volume level (N°4) to your own choice.

The final audio result will be linked to the quality of your set up adjustments.

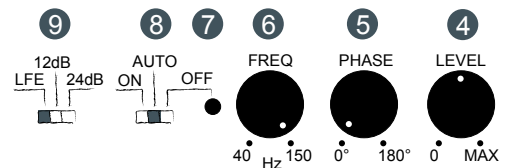

C) Connection of your Subwoofer and settings in Stereo

• Your Subwoofer can be connected to your stereo amplifier in two different ways :

Configuration A : If your amplifier is equipped with a "pre out" output, connect it via a stereo modulation cable (not supplied) to the "low level input" (N°11) of your subwoofer. Connect your speakers directly to your Stereo amplifier.

Configuration B : Your amplifier doesn't have a "Pre Out" output. Connect the "High level Input" (N°12) to the amplifier. Please check for the right polarities (+) red (-) black.

An Error would result into destroying both your Stereo amplifier and your Subwoofer.

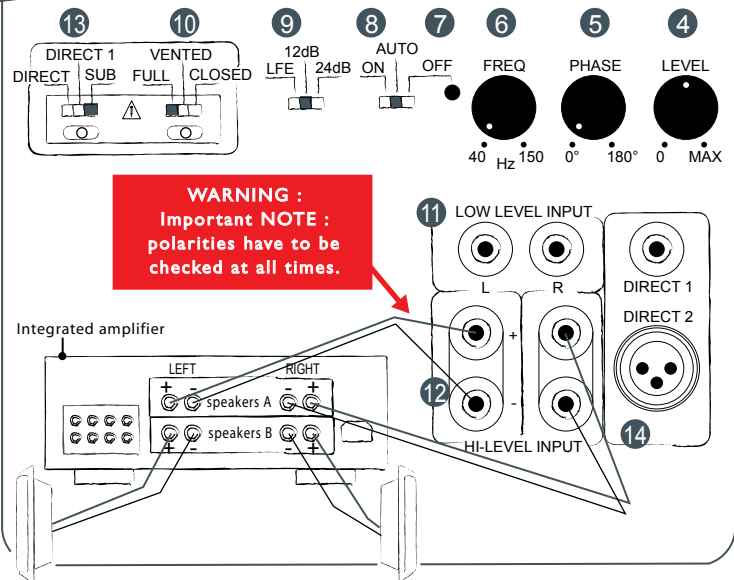
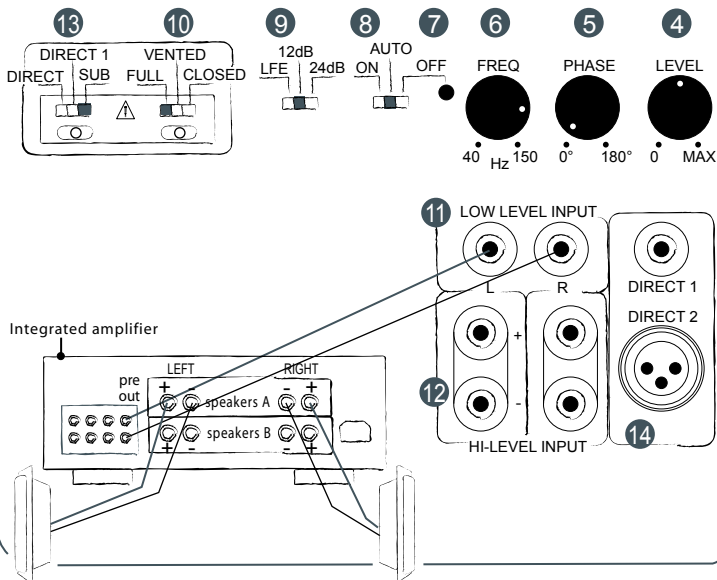

• In both cases, please set up the HF3 IP's amplifier as described below

- Freq (N°6) on 130 Hz (as shown) if you use Serio, Hurricane Evo or Elora, 60 Hz if you use an Iguasçu Evo or Victoria Evo.
- "24-12-LFE" (N°9) switch must be on the "12" position,
- Phase (N°5) should be on 0° in most of the cases. Phase may be adjusted if necessary.
- Adjust the volume level (N°6) to your own choice.

D) Warranty

See Waterfall Warranty Card

This document is to be included in any resale of the product.



All drivers are developed and manufactured by Atohm (France).

Unité de fabrication et bureaux : ZA Praderies, 83 570 Carcès - France - Tel : +33 (0)4 98 05 11 30 - Fax : +33 (0)4 98 05 11 31 - contact@waterfallaudio.com

www.waterfallaudio.com