

BeoLab 7-1
BeoLab 7-2

Guide

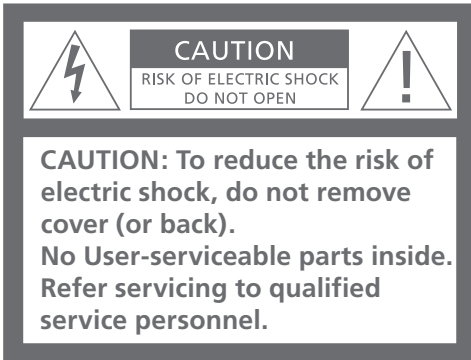

WARNING: To prevent fire or electric shock, do not expose this appliance to rain or moisture. Do not expose this equipment to dripping or splashing and ensure that no objects filled with liquids, such as vases, are placed on the equipment.

To completely disconnect this equipment from the AC Mains, disconnect the power supply cord plug from the AC receptacle.



This symbol indicates that a dangerous voltage constituting a risk of electric shock is present within this unit.



This symbol indicates that there are important operating and maintenance instructions in the literature accompanying this unit.

Cautions!

- Make sure that the loudspeaker is placed and connected in accordance with the instructions in this Guide.
- Do not attempt to open the loudspeaker. Leave such operations to qualified service personnel!
- The loudspeaker is designed for indoor use in dry, domestic environments only, and for use within a temperature range of 10–40° C (50–105° F).
- In order not to block the sound emitting from the rear bass reflex ports and the bass units on the bottom, leave a minimum of 6 cm (2½") free space behind and below the loudspeaker.
- Always place the loudspeaker in a horizontal position, and do not place any items on it.
- *Prolonged listening at high volume levels may cause hearing damage!*

When you have finished setting up the loudspeaker as described on the following pages, connect the entire system to the mains.

Loudspeaker protection

The loudspeaker is equipped with a thermal protection system which prevents damage from overheating. If an error occurs – or the speaker units become overheated – the system automatically switches the loudspeaker to standby.

To restore the sound:

- > Disconnect the loudspeaker from the mains.
- > Allow the system time to reset or cool down (approximately 3–5 minutes).
- > Reconnect the loudspeaker to the mains.

Should the problem persist, contact your Bang & Olufsen retailer.

Cleaning the loudspeaker

Clean dusty surfaces using a dry, soft cloth. If necessary, remove grease stains or persistent dirt with a lint-free, firmly wrung cloth, dipped in a solution of water containing only a few drops of mild detergent, such as washing-up liquid.

The loudspeaker front grill may be cleaned with a vacuum cleaner with a soft brush nozzle, and set to the lowest level.

Never use alcohol or other solvents to clean any parts of the loudspeaker!

Switching on and off

When you switch on your Bang & Olufsen system, the loudspeaker switches on simultaneously, and when you switch the system off again the loudspeaker also switches off.



Caution: *Handle the loudspeaker front grill with great care. Dents and scratches are not covered by the guarantee!*

Set up the loudspeaker

We recommend that you follow this procedure:

- Disconnect your Bang & Olufsen system from the mains.
- Mount the loudspeaker to the Bang & Olufsen stand or wall bracket as explained on the next page.
- Connect the loudspeaker as explained in 'Cable connections' (pp. 6–7).
- Set the POSITION switch to the correct setting. This is explained in 'Adapt the loudspeaker to your room' (pp. 8–9).
- Connect the entire system to the mains again.

In order not to dent or scratch the loudspeaker front grill, we recommend that you lift the loudspeaker by holding on to the two bass units on the bottom. Do not support the loudspeaker holding the loudspeaker front grill!

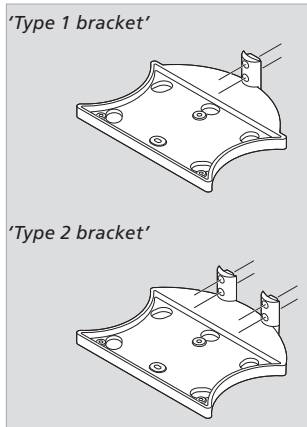

BeoLab 7 brackets: *The loudspeaker must be fastened to one of the brackets shown here, and on a suitable Bang & Olufsen stand or wall bracket.*

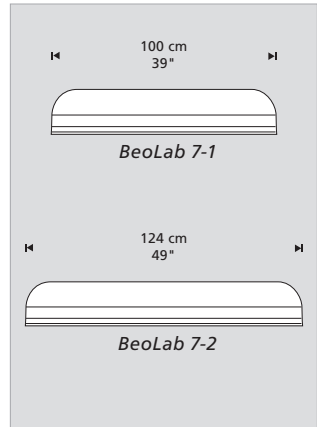

BeoLab 7-1: *Always use the 'type 1 bracket'.*

BeoLab 7-2: *Use the 'type 2 bracket' when the loudspeaker will be fastened to one of the 'double-column' Bang & Olufsen stands. However, use the 'type 1 bracket' if the loudspeaker will be fastened to a wall bracket – for example below a BeoVision 4 screen.*

Here is shown how to fasten the loudspeaker with a 'type 1 bracket' to a Bang & Olufsen 'single-column' stand (or wall bracket). Use the same procedure if you wish to fasten the loudspeaker to a Bang & Olufsen 'double-column' Stand – with a 'type 2 bracket'.

- a Remove the small cover (if any) on the stand. Press the cover as shown, and it will come loose.
- b Fasten the bracket to the stand or wall bracket. Use the two longest screws (M5 × 25 mm) – four screws for a 'type 2 bracket'.
- c Fasten the loudspeaker to the bracket. Use the two shortest screws (M5 × 8 mm). However, do not fully tighten the screws before you have made the adjustments mentioned below (d).

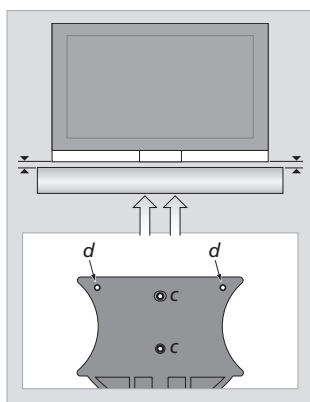
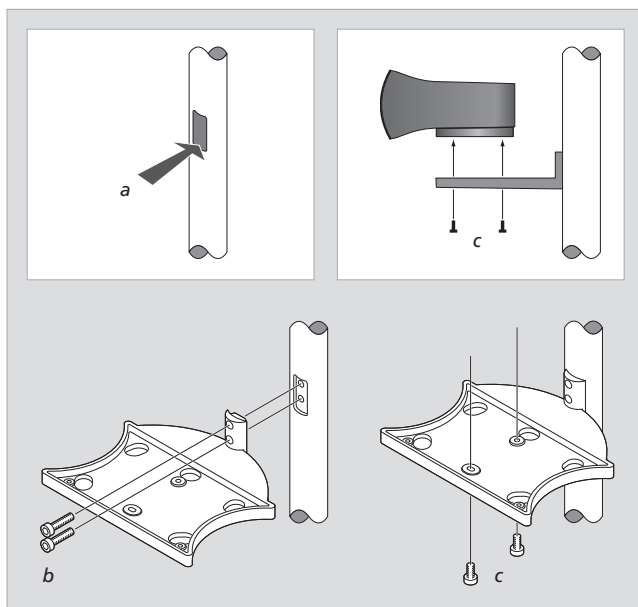

Adjustments: First, make sure that the television is adjusted to a level position on its stand or wall bracket! Then use the two screws (d) to adjust the loudspeaker so that it is parallel to the lower edge of the television. Align the loudspeaker front with the television and tighten the two screws (c).

NOTE! BeoVision 7 and its accessories are not available on all markets.

Cable connections

The loudspeaker is primarily intended to be used in a setup with BeoVision 7*. It may, however, be used with other Bang & Olufsen systems as well – for example in a BeoVision 4 setup.

If used in a setup *not including* BeoVision 7, you will require a mains cord and a Power Link cable. These cables are available as optional accessories from your Bang & Olufsen retailer.

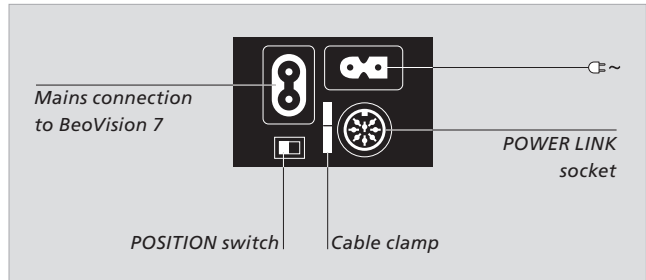

The socket panel is located on the rear of the loudspeaker.

Mains connections

The loudspeaker has two sockets concerning mains supply.

The socket marked ~ is for mains supply input (connection from the wall outlet), and the other is a mains supply output to BeoVision 7 (this socket is not available on loudspeakers intended for the US-market).

Note: The mains cord from the wall outlet must be fastened to the cable clamp on the loudspeaker – as shown on the next page.

POSITION switch

This switch has two settings: **F** (Free-standing position) and **W** (Wall position).

Which setting to use is explained in *'Adapt the loudspeaker to your room'* (pp. 8–9).

POWER LINK socket

Use this socket to connect the loudspeaker to one of the Power Link sockets on the Bang & Olufsen system – see the next page.

*NOTE! BeoVision 7 and its accessories are not available on all markets.

Connection to BeoVision 7 ...

Connect the loudspeaker to one of the Power Link sockets on the left BeoVision 7 socket panel.

For further information about the BeoVision 7 socket panels, refer to the Guides enclosed with the product.

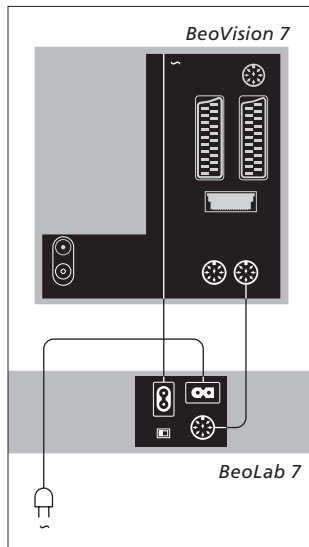

The two mains cords and the Power Link cable are enclosed with BeoVision 7.

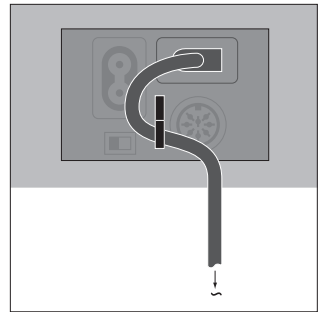

Cable clamp: For safety reasons, the mains cord from the wall outlet must be secured to the loudspeaker. To do so, tug the cord behind the clamp.

Connection to other Bang & Olufsen systems ...

Use a Power Link cable of the correct type to connect the loudspeaker to a Power Link socket on the Bang & Olufsen system.

For further information, refer to the Guide enclosed with the Bang & Olufsen system.

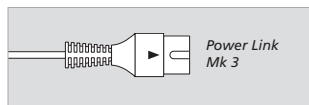

Power Link cable: Do not use a cable of the older type, as this will cause noise, and therefore not give optimum sound quality! The new type has a triangular mark on the plug.

Adapt the loudspeaker to your room

When a loudspeaker is placed in a corner or close to a wall, the bass level is boosted compared to the bass level from a loudspeaker placed in a more free-standing position.

To remove this excessive bass boost, use the POSITION switch to ensure that the bass level suits the placement of the loudspeaker. The appropriate switch setting depends on the distance from the loudspeaker to the walls and corners of the room.

The POSITION switch

- **F** (Free-standing position)
Use this setting if the loudspeaker is placed so that the front grill is more than 50 cm (20") from the rear wall, for example on one of the floor or table stands.

- **W** (Wall position)
Use this setting if the loudspeaker is placed so that the front grill is less than 50 cm (20") from the rear wall.

Always use this setting if the loudspeaker is placed on any of the wall brackets, but also when placed on one of the stands – close to the rear wall.

If the loudspeaker is fitted to one of the table stands – and you have chosen to place it on the floor – you should set the POSITION switch to **W**.

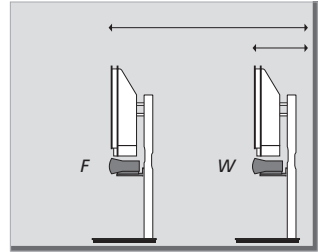

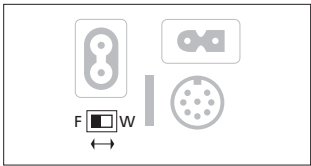

The POSITION switch is located on the loudspeaker socket panel.

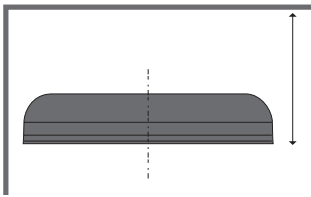

How to measure ... The distance is measured as shown here – the loudspeaker seen from above.

To get access to the approval labels, remove the loudspeaker front grill:

Push the front grill towards the left (~ 10 mm). The front grill can now be removed.

Note: When attaching the front grill again, make sure that all five 'attach-points' engage with the corresponding brackets on the loudspeaker. Do not attempt to mount the front grill upside down (marked on the rear by ↑UP).

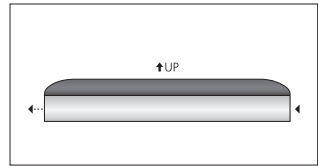

Caution: *Handle the loudspeaker front grill with great care. Dents and scratches are not covered by the guarantee!*

For the Canadian market only!

This class B digital apparatus meets all requirements of the Canadian Interference-Causing Equipment Regulations.

 This product fulfils the conditions stated in the EEU directives 89/336 and 73/23.

Technical specifications, features and the use thereof are subject to change without notice!

For the US-market only!

NOTE: This equipment has been tested and found to comply with the limits for a class B digital device, pursuant to part 15 of the FCC Rules. These limits are designed to provide reasonable protection against harmful interference in a residential installation.

This equipment generates, uses and can radiate radio frequency energy and, if not installed and used in accordance with the instructions, may cause harmful interference to radio communications. However, there is no guarantee that interference will not occur in a particular installation. If this equipment does cause harmful interference to radio or television reception, which can be determined by turning the equipment off and on, the user is encouraged to try to correct the interference by one or more of the following measures:

- Reorient or relocate the receiving antenna.
- Increase the separation between the equipment and receiver.
- Connect the equipment into an outlet on a circuit different from that to which the receiver is connected.
- Consult the retailer or an experienced radio/TV technician for help.

