XG700 Hardware Guide

Preface

You have purchased the XG700, a compact, 12 port 10 Gigabit Ethernet layer 2 switch that achieves unsurpassed standards of high throughput and low-latency performance. This manual explains the procedures required to install your XG700 and should be read and understood before you start using your XG700.

First edition (September 2005)

All Rights Reserved, Copyright © PFU LIMITED 2005

For Safe Use of the XG700

This manual contains important information to ensure the safe use of your XG700. Be sure to thoroughly read and understand its contents before attempting to use the XG700. After reading, store this manual in a safe place for future reference. PFU has made every effort to ensure the safety of the user and others, and to prevent property damage. When using the XG700, follow the instructions given in this manual.

Warning notations

Warnings are included throughout this manual in order to prevent injury to the user and/or material damage. These are two levels of warnings, both of which are composed of a symbol and a message describing the issue.

 **WARNING** This symbol indicates the possibility of serious or fatal injury if the XG700 is not used properly.

 **CAUTION** This symbol indicates the possibility of minor or moderate personal injury, as well as damage to the XG700 and/or to other users and their property, if the XG700 is not used properly.



WARNING This symbol indicates the possibility of serious or fatal injury if the XG700 is not used properly.

For your safety and that of others, please follow these guidelines.

Category	Warning
Danger of electric shock or fire	Never attempt to disassemble, dismantle, upgrade, or recycle the XG700 by yourself. Do not place objects on the XG700, as there is a risk of electric shock, fire, and/or damage.
	Do not install the XG700 where it will be exposed to direct sunlight, close to a heating device, or in an environment with much dust and high humidity, as there is a risk of electric shock and fire.
	For XG700 models with cooling vents, do not block off the vents as these prevent the internal parts of the XG700 from reaching high temperature, and there is a risk of fire.
	Do not wrap the running XG700 with a cloth. Doing so keeps the heat in, and may cause a fire.
	Avoid getting any liquids (such as coffee) or pieces of metal (such as paper clips) into the XG700, as there is a risk of electric shock and fire. To avoid foreign objects getting into the XG700, never place objects on it.
	Do not put your fingers into the LAN jack, as there is a risk of electric shock.
	Do not use the XG700 with any voltage other than that specified on the device, as there is a risk of electric shock and fire.
	Should the XG700 start giving off heat, smoke, and/or a strange smell, immediately disconnect the power plug from the power outlet. To make this easy, the XG700 should be located close to the power outlet (wall socket or power strip), and the power outlet must be readily accessible. After the power is disconnected, contact the vendor's service department immediately. Continued use of the XG700 may cause an electric shock and fire. Note that in this case, the state of data in transmission is not guaranteed.(P.30)
	If the power plug or power socket is dirty, clean it with a dry cloth. Continued use may cause a fire.(P.28)
	Do not touch the power plug with wet hands, as there is a risk of electric shock.(P.28)
	Insert the power plug completely into the power socket. A partially inserted power plug may cause an electric shock, give off smoke, and/or catch fire.(P.28)
	When you remove a power plug from its outlet, be sure to pull the only power plug itself. Pulling on the power cord itself may expose the cores or break the cord, and cause electric shock or fire.(P.28)
	If the XG700 is to be left unused for any significant period, remove the power plug from the outlet for safety reasons. Failure to do so may cause a fire or damage.(P.28)
	Do not damage or remodel the power cords, as this may cause electric shock or fire. Do not place any object on, wrap any object with, pull and/or kick the power cords, as there is a risk of electric shock and fire.(P.28)
	Never overload a power outlet with multiple devices. If too many devices are connected, the power socket may overheat and cause a fire.
	When you remove a power plug from an outlet, be sure to pull the power plug itself. A power plug damaged by incorrect removal may cause an electric shock and fire.
	Do not use the XG700 with a damaged power cord, a damaged power plug, and/or a loose socket. Continued use under these conditions may cause an electric shock and fire.(P.28)
Do not bundle the power cords. Doing so increases the heat density, and may cause a fire.	
Unplug the XG700 during thunder-storms. Continued use under these conditions risks lightning damage to the XG700, and may cause a fire.(P.28)	
Danger of breakage and injury	Do not place the XG700 on its side or stack up multiple XG700s. Ignoring this may damage the XG700 or injure the operator.
	Do not install the XG700 in an unstable place (such as on a slanted surface or a place subjected to vibrations). Doing so may cause injury or device damage.
	Do not place any objects or perform any work on the XG700. Ignoring this may damage the XG700 or injure the operator.
	Never leave the plastic bags the XG700 was packed in around where children can find them, as they may suck them into their mouths or place them over their heads in fun, with a severe risk of choking and asphyxia.
	Do not dispose the XG700 with other wastes. If burnt, the XG700 can explode.



This symbol indicates the possibility of minor or moderate personal injury, as well as damage to the XG700 and/or to other users and their property, if the XG700 is not used properly.

Category	Caution
Danger of device damage	Do not place the XG700 on its side or stack up multiple XG700s. Doing so may damage the XG700.
	Do not install the XG700 in an unstable place (such as on a slanted surface or a place subjected to vibrations). Doing so may damage the XG700.
	Do not place any objects or perform any work on the XG700. Doing so may damage the XG700.
	Install the XG700 inside a building. Using the XG700 outside may damage it.
	Do not use the XG700 in areas of extremely high temperature, low temperature, or a area where the temperature goes up and down suddenly. Installing the XG700 in such areas may damage it.
	Do not expose the XG700 to seawater. Installing the XG700 in such areas may damage it.
	Do not use the XG700 in a place subjected to shock or vibrations. Using the XG700 in such a place may damage it.
	Do not use the XG700 in a place where chemicals are being sprayed or may otherwise come in contact with it. Using the XG700 in such a place may damage it.
	Do not use the XG700 near objects which generate strong magnetic fields, such as microwave ovens. Using the XG700 in such place may damage it.
	Do not use the XG700 with foreign objects (liquids and/or pieces of metal) inside it. Using the XG700 in such a condition may damage it.
	When moving the XG700, be sure to remove the power plug from the outlet first. No doing so may damage it.
Danger of electromagnetic interference	Do not use the XG700 near a radio or a TV. Doing so can interfere with the radio and TV reception.
Danger of electric shock	To avoid an electric shock, do not open the cover unless you are a maintenance engineer. When performing maintenance on the XG700, be sure to remove the power plug from the outlet first.
Danger when rackmounting	Only use the XG700 if the temperature inside the rack is 40°C or less. Ignoring this may damage the XG700 (P.22).
	Ensure that the rack is sufficiently ventilated and that excess heat is properly exhausted (P.22).
	Check that the configuration of devices in the rack does not overload the power supply (P.22).
	To ensure the stability of the rack, fix it to the wall or floor as appropriate (P.22).
	Do not install the XG700 in a rack if it would make it unstable (P.22).
	Check that all units installed in the rack are correctly connected to a grounded power source (P.22).
	When installing and removing the XG700 from a rack, be sure to hold it by both sides. At least two people should work together.(P.23)(P.26)
Danger when cleaning	When cleaning the XG700, only use a soft cloth, and wipe it gently.

No self maintenance

Never attempt to dismantle or modify the XG700 yourself. This is extremely dangerous since the XG700 includes both high voltage and high temperature components. If maintenance is required, contact the vendor's service department.

Warning label

The following warning label may be found on the rear of XG700. Do not attempt to remove this warning label. If you cannot read the details written in the warning label because of dirt or wear, contact the vendor's service department for a replacement label.

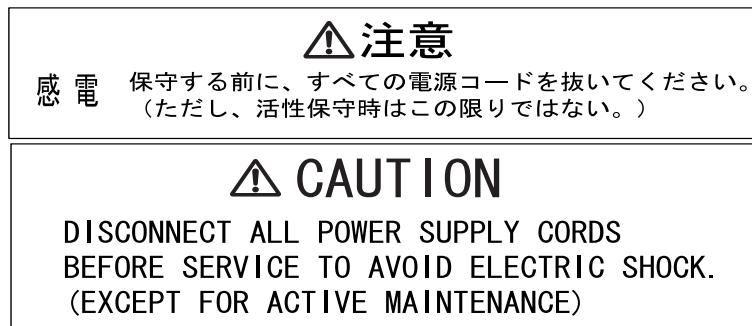

Safety precautions

- The expected life of the XG700 is approximately five years, assuming use at an ambient temperature of 25°C.
- Use of this hardware guide, the XG700, its firmware, and the management software are the responsibility of the user.
- Fujitsu and its partners accept no responsibility for any errors or data loss arising from use of the XG700. Before using the XG700, it should be understood that the XG700 is not guaranteed against failure for any more than the original purchase price.
- Fujitsu and its partners do not approve of any use of the firmware provided with the XG700, or of any authorized firmware upgrades, for any purpose other than installation on the XG700. Modification and disassemble are not permitted at all.

For security

A default login password is set before the XG700 is shipped. For security reasons, a new password should be chosen before the XG700 is used.

Electromagnetic compatibility

FCC Class A
CE Marking

Safety

CAN/CSA C22.2 No. 60950, UL60950 and EN60950

Static electricity

Under certain conditions, twisted pair cables can become charged with static electricity. Connecting a statically charged twisted pair cable to a device can cause the device or its LAN port to operate falsely or to become damaged.

Use a static removal tool to discharge twisted pair cables to ground immediately before connecting them to devices.

Note that a discharged twisted pair cable that has been left unconnected for a long time may become statically charged again.

High safety

[Use for the high safety required case]

The XG700 is designed, developed and manufactured as contemplated for general use, including without limitation, general office use, personal use, household use, and ordinary industrial use, but is not designed, developed and manufactured for use in situations with accompanying fatal risks or dangers that, unless extremely high safety is secured, could lead directly to death, personal injury, severe physical damage or other loss (hereinafter "High Safety Required Use"), including without limitation, nuclear reaction control in nuclear facility, aircraft flight control, air traffic control, mass transport control, medical life support system, and missile launch control in weapon systems.

Do not use the XG700 for High Safety Required Use without otherwise ensuring the safety level required. Fujitsu and its related companies assume no liability whatsoever for damages arising from use of the XG700 by the user in high-safety applications, and for any claims or compensation for damages by the user or a third party.

About This Manual

This section explains who this manual is aimed at, describes the layout of the manual, and gives a description of the symbols used in this manual.

Targeted reader and expected knowledge

This manual is written for an administrator who has responsibility for network system configuration, maintenance, and management.

Understanding the following knowledge is expected.

- Basic knowledge of networks, intranets and the internet.
- Basic knowledge of system management.
- Basic knowledge of system security.

This manual does not give any explanation of network protocol terms.

Organization

This manual is organized as follows.

Chapter 1 Before Use

This chapter lists the items that should be in the XG700 package, describes the names and functions of the various components of the XG700.

Chapter 2 Installation and Operation

This chapter explains how to install, connect, and start the XG700.

Chapter 3 Troubleshooting

This chapter describes what you should do when your XG700 has problems.

Appendix

This appendix explains the specifications of the XG700, and should be referred to as necessary.

Related manuals

The following manuals are related to this manual. Consult them as required.

- XG700 Hardware Guide (this manual)
This manual describes the hardware of the XG700.
- XG700 User's Guide
This manual describes a variety of operations and procedures, including the installation and maintenance of the XG700.

When referring to the "XG700 User's Guide", the manual name is usually abbreviated as "User's Guide".

The user's guide is an online manual, contained in the "XG700 User's Guide CD-ROM".

Symbols used in this manual

This manual uses the following symbols.



This symbol indicates a point that operator should pay attention to.



This symbol indicates supplemental information.



This symbol indicates a section which describes related information.



This symbol means "Danger! You are in a situation that could result in bodily injury". Before continuing, make yourself aware of the hazards involved and become familiar with common ways of preventing accidents.



This symbol means "Be careful, or you might do something that could damage your equipment or result in loss of data".

Trademarks and abbreviations used in this manual

Company names and products names referred in this manual are registered trademarks or trademarks of respective companies.

The trademark [™] and © have been omitted from this manual.

Product Information

The latest product information including technical information, update information, are available from the following web site:

<http://www.pfu.fujitsu.com/products/xg>

Contents

Preface	1
For Safe Use of the XG700	2
Warning notations	2
No self maintenance	5
Warning label	5
Safety precautions	5
For security	5
Electromagnetic compatibility	6
Safety	6
Static electricity	6
High safety	6
About This Manual	7
Targeted reader and expected knowledge	7
Organization	7
Related manuals	7
Symbols used in this manual	8
Trademarks and abbreviations used in this manual	8
Product Information	8



Chapter 1 Installation..... 11

1-1 Parts List	12
1-2 XG700 Components	14
1-3 Labels	17

Chapter 2 Installation and Operation 19

2-1 Installation Overview	20
2-2 Installation Procedure	21
2-2-1 Installation requirements	21
2-2-2 Installing the XG700 in a rack	23
2-2-3 Uninstalling the XG700 from a rack	26
2-3 Cable Connection	27
2-3-1 Connecting cables	27
2-3-2 Connecting the power cords	28
2-4 Basic Operation	30
2-4-1 Turning the XG700 on	30
2-4-2 Turning the XG700 off	30

Chapter 3 Troubleshooting 31

3-1 Start-up Problems	32
3-2 Hardware Problems	33

Appendix..... 35

Appendix-A Specifications 36
 A.1 Product Specifications 36
 A.2 Installation Specifications 36

Installation

This chapter lists the items that should be in the XG700 package, describes the names and functions of the various components of the XG700.



1-1 Parts List.....	12
1-2 XG700 Components.....	14
1-3 Labels.....	17

- **Rack Mounting Brackets**
Brackets for mounting the XG700 in a rack. Attach each rack mounting bracket to the right and left sides of the XG700, and fasten to the rack posts with the rack screws (large).
- **Rack Mounting Bracket BR**
A bracket for mounting the XG700 in a rack. Attach the rack mounting bracket BR to the back-right side of the XG700, and fasten to the rail (attached to the back-right rack post) with the rack screws (small).
- **Rack Mounting Bracket BL**
A bracket for mounting the XG700 in a rack. Attach the rack mounting bracket BL to the back-left side of the XG700, and fasten to the rail (attached to the back-left rack post) with the rack screws (small).
- **Rail R**
A rail that are attached to the back-right rack post and into which the back rack mounting bracket are slid and fastened when mounting the XG700 in a rack.
- **Rail L**
A rail that are attached to the back-left rack post and into which the back rack mounting bracket are slid and fastened when mounting the XG700 in a rack.
- **Bracket Screws**
Countersunk screws for fixing the rack mounting brackets (L, R, BL, and BR) to the XG700.
- **Rack Nuts**
When the rack post holes are round, use the rack nuts to fasten the XG700 and the rails to the rack posts with the rack screws (large).
- **Cage Nuts**
When the rack post holes are square, use the rack nuts to fasten the XG700 and the rails to the rack posts with the rack screws (large).
- **Rack Screws (Large)**
Pan-head screws for fixing the XG700 and the rails to the rack posts.
- **CD-ROM**
Contains documents necessary to operate the XG700.
- **Hardware Guide**
A manual describing the XG700 hardware and related matters (this manual).
- **Rack Screws (Small)**
Pan-head screws for fixing the back rack mounting brackets (BL, BR) to the rails.
- **Wrist Strap**
Used when performing maintenance on the XG700.

1-2 XG700 Components

This section explains the names and functions of the various XG700 components, including the various indicator LEDs.

XG700 front

The following explains the names and functions of the components at the front of the XG700.

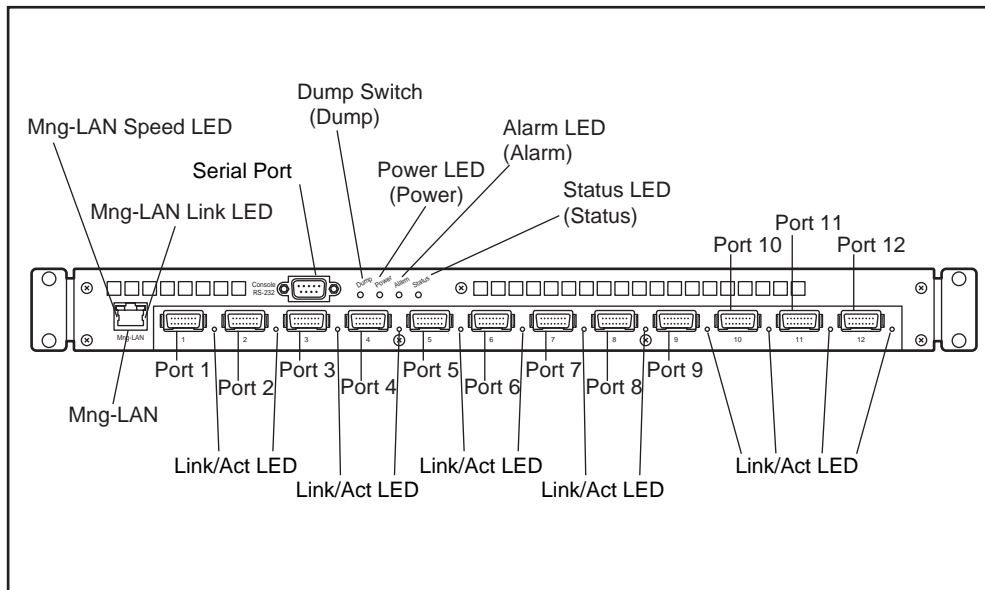

- Power LED (Green) Lights when the XG700 is receiving power.
- Alarm LED (Orange) Lights when there is a problem with the XG700.
- Status LED (Green) Lights when the XG700 is in an operable state.
- Serial Port Used when performing maintenance or adjusting the settings (Console connection).
- Mng-LAN Used when performing maintenance or adjusting the settings (LAN connection).
 - Mng - LAN Speed LED (Orange) Lights if the link is 100BASE-TX.
 - Mng - LAN Link LED (Green) Lights when the link is established.
- Ports 1-12 Xenpak modules which connect to the IEEE802.3 ak compliant 10 Gigabit network served by the XG700.
- Link/Act LEDs (Green) Displays the condition of respective port. Each LED lights when a link is established on its port. The link is established about fifteen seconds after the received signal is detected.
- Dump Switch Used to collect maintenance information.

XG700 rear

The following explains the names and functions of the components at the rear of the XG700.

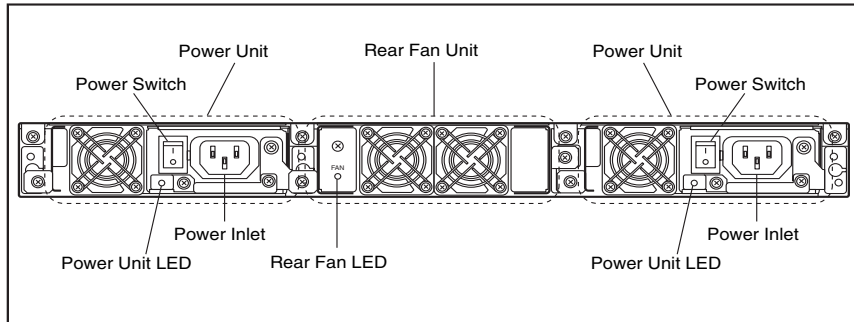

1

- Power Switch Used to turn the XG700 on/off.
- Power Supply Unit Supplies power to the XG700 (includes an exhaust fan).
 - Power Supply LED (Green/Orange)
Green LED lights when the XG700 is on. Orange LED lights when there is a problem with the Power Supply Unit.
- Rear Fan Unit Exhaust fan.
 - Rear Fan LED (Green/Orange)
Orange lights when there is a problem with the Rear Fan Unit.

CAUTION

In order to avoid a negative effect on the cooling of the XG700, the Rear Fan Unit screws should be kept tight at all times.

Display LEDs

There are three main indicator LEDs on the front of the XG700: Power LED, Alarm LED, and Status LED. The following explains the LED display under various conditions.

XG700 Condition		LED		
		Power	Alarm	Status
Off		Off	Off	Off
Starting up	Power just turned on	On	On	Off
	System starting up	On	Off *1	Blinking
	System start-up completed	On	Off *1	On
Operable		On	Off *1	On
After shutdown		On	Off*1	Off

*1: If the XG700 is operating normally.

If a problem occurs, the front panel LEDs and the LEDs on the individual parts can be used to identify the trouble:

XG700 Condition		LED			
		Power	Alarm	Status	LED on failed part
Problem detected	Startup error	On	Blinking	Blinking	---
	Rear fan error	On	On	---*3	Rear Fan LED: Orange
	Power fan error	On	On	---*3	Power Supply LED: Orange
	No AC supply *2	On	On	---*3	Power Supply LED: Orange
	Power supply error	On	On	---*3	Power Supply LED: Orange
	Voltage error	On	On	---*3	---
	Temperature error	On	On	---*3	---
	System dump in progress	On	On	---*3	---

*2: Only detectable and indicated when two power supply units are installed and connected to separate, independent power supplies.

*3: Condition of the Status LED will depend on the state of the system.

Note that the XG700 does not shut itself off when trouble is detected.

Any problems other than those that occur during start up are recorded in the event log. For details of the event log, refer to the "XG700 User Guide".

1-3 Labels

A warning sticker, product nameplate, product ID label, and MAC label are to be found in various places on the XG700.

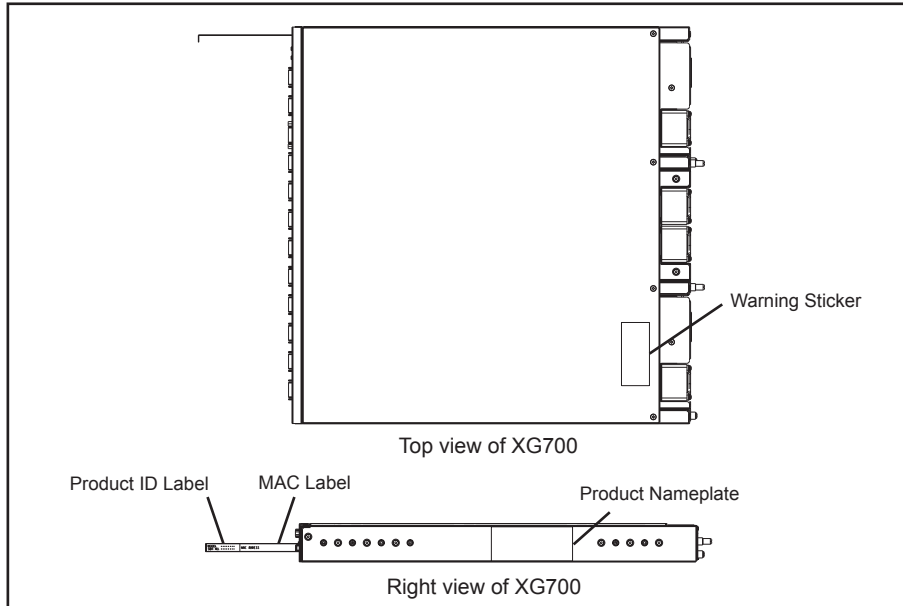

1

Warning sticker

Obey the following warning:

⚠ 注意
感電 保守する前に、すべての電源コードを抜いてください。
(ただし、活性保守時はこの限りではない。)

⚠ CAUTION
DISCONNECT ALL POWER SUPPLY CORDS
BEFORE SERVICE TO AVOID ELECTRIC SHOCK.
(EXCEPT FOR ACTIVE MAINTENANCE)

Product nameplate

This indicates the model, part number, serial number, etc.

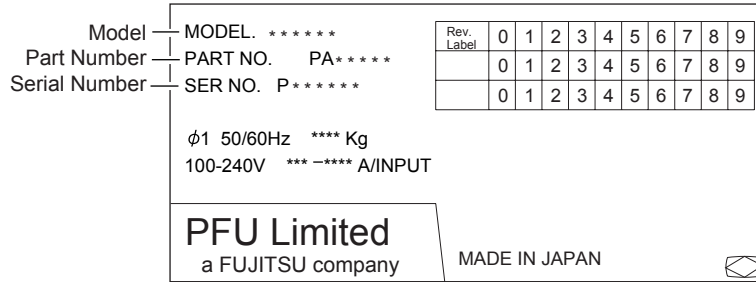

Product ID Label

This indicates the model and serial number.

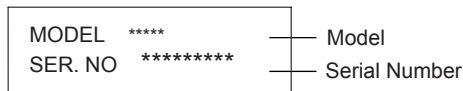

MAC Label

This indicates the MAC address:

MAC Address:xx:xx:xx:xx:xx-yy:yy:yy:yy:yy

MAC addresses are allotted relative to the address on the MAC label:

Address on the MAC label	Location
xx:xx:xx:xx:xx:xx	Mng-LAN
xx:xx:xx:xx:xx:xx+1	XG700
xx:xx:xx:xx:xx:xx+2	Port 1
xx:xx:xx:xx:xx:xx+3	Port 2
xx:xx:xx:xx:xx:xx+4	Port3
xx:xx:xx:xx:xx:xx+5	Port 4
xx:xx:xx:xx:xx:xx+6	Port 5
xx:xx:xx:xx:xx:xx+7	Port 6
xx:xx:xx:xx:xx:xx+8	Port 7
xx:xx:xx:xx:xx:xx+9	Port 8
xx:xx:xx:xx:xx:xx+10	Port 9
xx:xx:xx:xx:xx:xx+11	Port 10
xx:xx:xx:xx:xx:xx+12	Port 11
xx:xx:xx:xx:xx:xx+13 (=yy:yy:yy:yy:yy:yy)	Port 12

Installation and Operation

This chapter explains how the user should proceed from installation to operation of the XG700.

2



2-1	Installation Overview	20
2-2	Installation Procedure	21
2-2-1	Installation requirements	21
2-2-2	Installing the XG700 in a rack	23
2-2-3	Uninstalling the XG700 from a rack	26
2-3	Cable Connection	27
2-3-1	Connecting cables	27
2-3-2	Connecting the power cords	28
2-4	Basic Operation	30
2-4-1	Turning the XG700 on	30
2-4-2	Turning the XG700 off	30

2-1 Installation Overview

This section reviews the flow of work as the user proceeds from installation to operation of the XG700.

Install the XG700 and then proceed with normal operation as follows:

1 Check the components

•▶ "1-1 Parts List"

2 Check the set up area and install the XG700

•▶ "For Safe Use of the XG700", "2-2 Installation Procedure"

3 Connect the cables to the XG700

Connect the required fiber optic cables and power cords to the XG700.

•▶ "2-3 Cable Connection"

4 Check that everything is secure

Check that the XG700 doesn't wobble and that no cables are loose.

5 Turn the power on

Check that the system starts up normally.

•▶ "2-4-1 Turning the XG700 on"

2-2 Installation Procedure

This chapter describes the installation requirements and installation procedure.

2-2-1 Installation requirements

Before installing the XG700, read " For Safe Use of the XG700 (P.2)" and comply with the installation requirements described below.

Space requirements

When installing the XG700, a certain amount of installation space is necessary. When installing the rack, the indicated space (800mm of both the front and rear of the rack) should be reserved as a service area. The following figures indicate examples of a 540mm (W) X 850mm (D) 19-inch rack and a 700mm (W) X 950mm (D) 19 inch rack.

2

When installing in any other 19-inch rack, refer to the user guide provided with the rack.

[540mm (W) 850mm (D) 19-inch rack]

(Unit: mm)

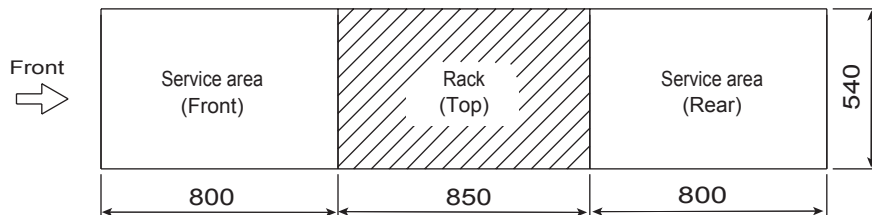

[700mm (W) 950mm (D) 19-inch rack]

(Unit: mm)

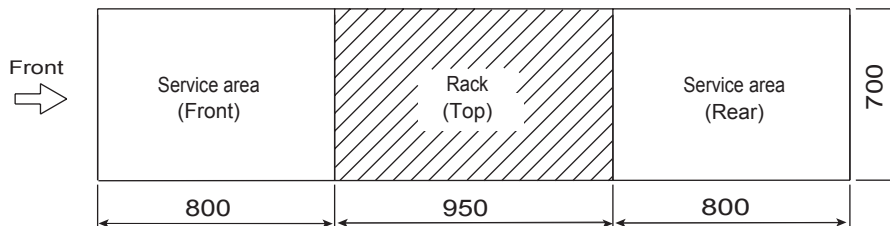

CAUTION

The XG700 may be installed in any rack with an internal depth of between 630mm and 750mm.

Set up requirements

Only use the XG700 under the temperature, humidity and other environmental conditions specified in "A.2 Installation Specifications (P.36)". Using the XG700 outside the following ranges can shorten the lifetime or cause the failure of the XG700.

Temperature (5 - 40°C)

Humidity (20 - 80%RH)

When installing the XG700 in a rack, note the following.

- Certain types of racks cannot be used. To check whether the XG700 can be installed in a given rack, contact the vendor's service department.

CAUTION

- Remember that when an installed unit is operating, the temperature inside the rack will be higher than the external ambient temperature, particularly if the rack contains multiple units. The rack's internal ambient temperature should not be allowed to exceed the maximum ambient temperature specified for each installed unit. The maximum ambient temperature allowed for the XG700 is 40°C.
- A certain amount of air is required for the XG700 to operate safely. Make sure that adequate ventilation is provided and that the front and rear air vents are not obstructed.
- Be careful that the rack is able to supply sufficient power for all the installed units. To avoid overloading the rack, check the power requirements specified for the each installed unit. The power requirement of the XG700 is 0.07KVA.
- Installing the XG700 in a rack may cause the entire rack to become unstable. To avoid this, fix the rack to the wall or floor as appropriate.
- Check that all the installed units are correctly grounded. Special care should be taken if the unit's power supply is not drawn directly from the distribution board (such as when a power strip is used, for example). When multiple devices are connected to a single power strip, the combined leakage currents can overwhelm the grounding capacity of the power strip.

2-2-2 Installing the XG700 in a rack

The following explains how to install the XG700 in a 19-inch rack.

1. Take the XG700 out of its box.
2. Fix the cage nuts and rails to the rack posts.

[When the rack has square post holes]

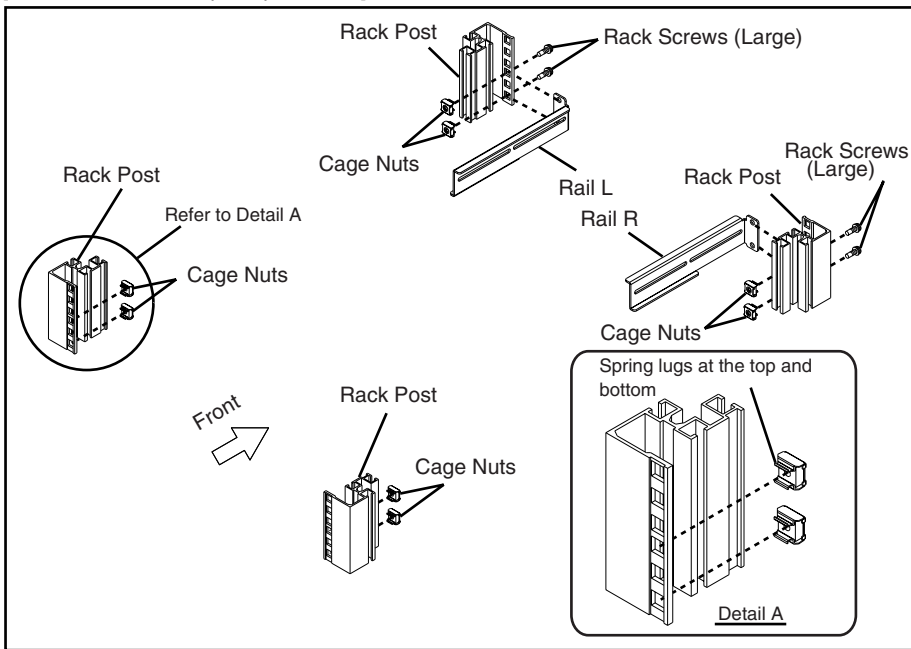

[When the rack has round post holes (top of view)]

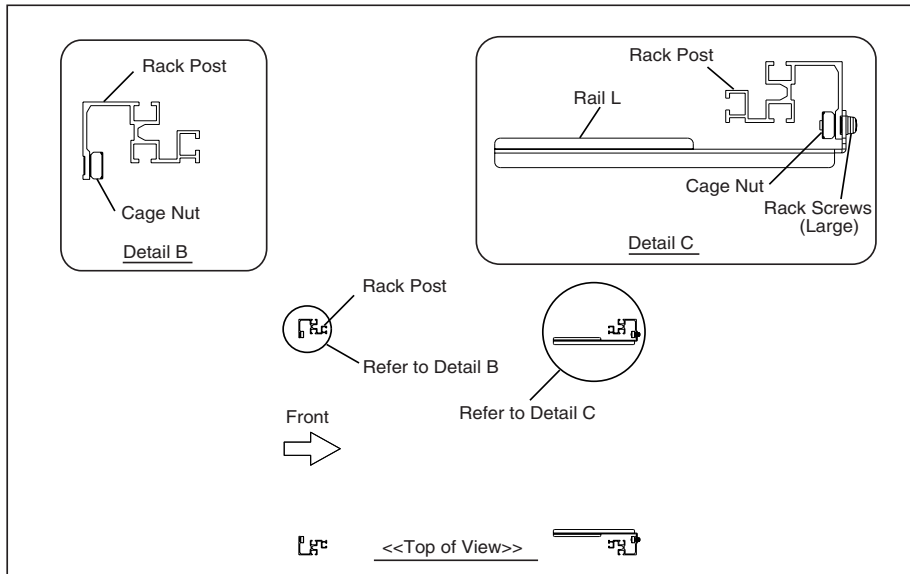

2

[When the rack has round post holes]

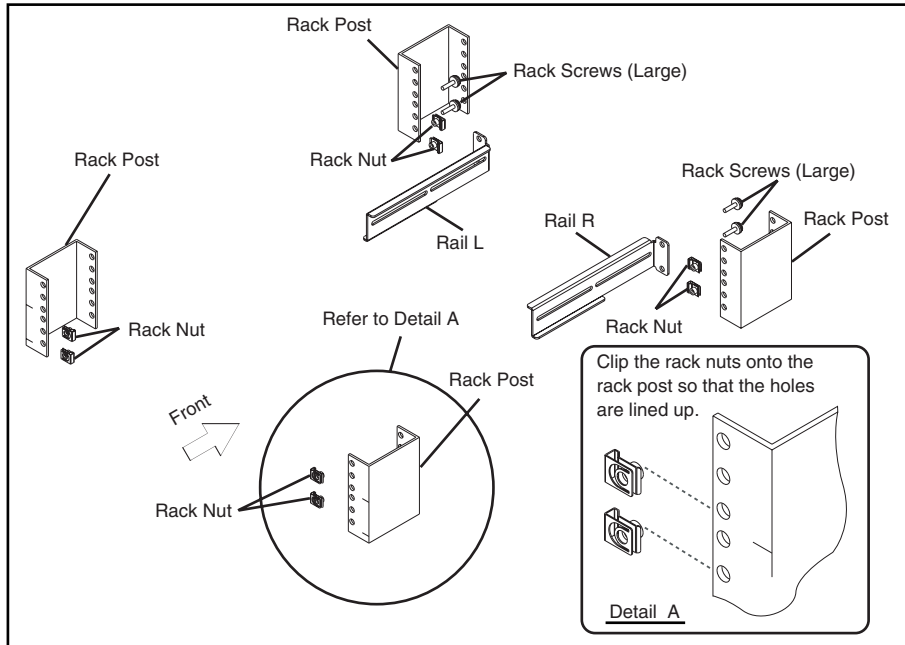

[When the rack has round post holes (top of view)]

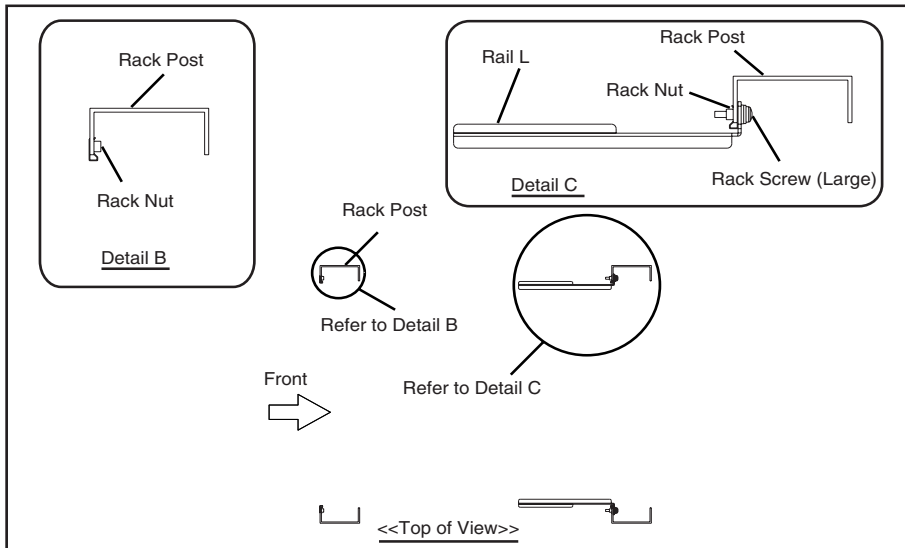

3. Fix the four rack mounting brackets to the XG700.

Each of the four rack mounting brackets (left, right, back-left, back-right) has three holes that should line up with matching holes on the sides of the XG700, as shown in the diagram. Attach each rack mounting bracket using the countersunk bracket screws provided.

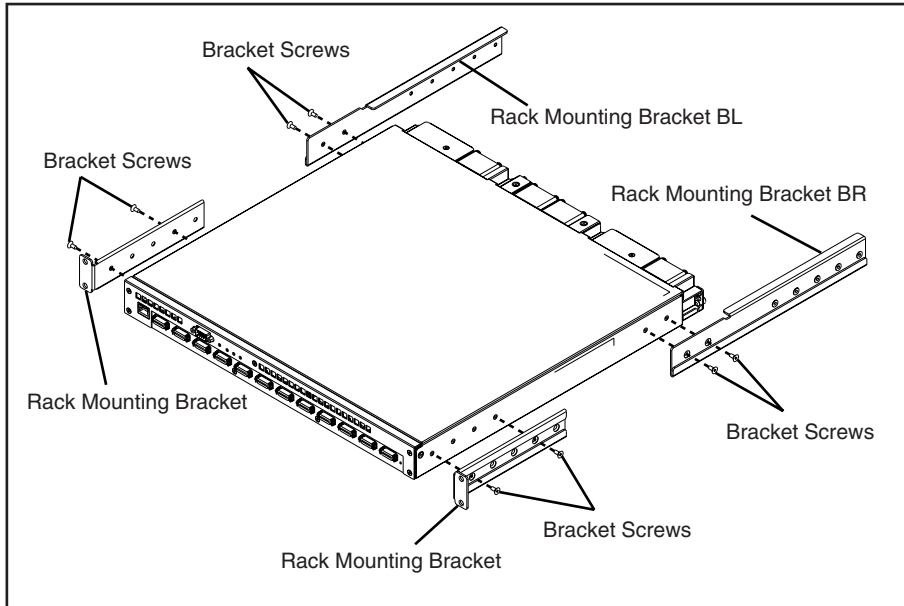

2

4. Slide the XG700 into the rack and fasten it in place.

Securely tighten all the screws with a screwdriver.

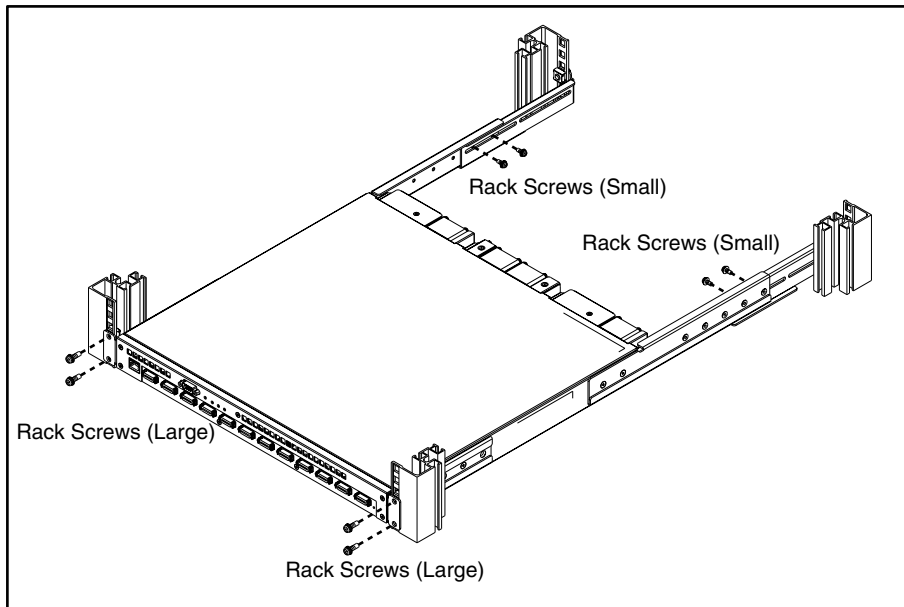

5. This completes the rack installation procedure.

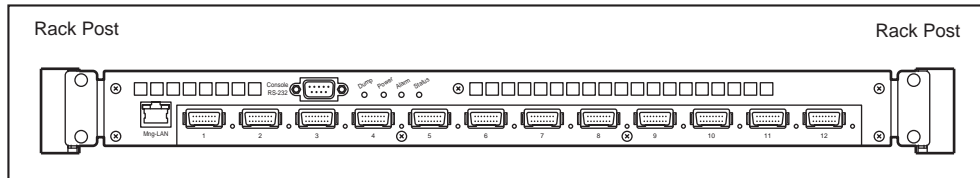

2-2-3 Uninstalling the XG700 from a rack

The following explains how to uninstall the XG700 from a rack.

1. Undo the rack screws that were used to fasten the XG700 to the rack.

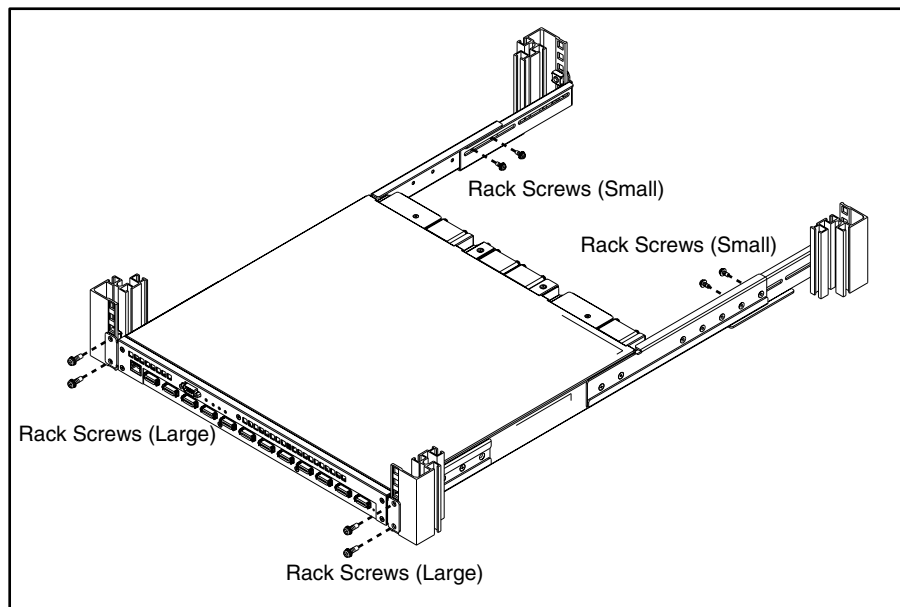

2. Slide the XG700 forward, and remove it from the rack.

2-3 Cable Connection

This section explains how to connect the cables and power cords.

2-3-1 Connecting cables

The cables need to be connected to the XG700 Xenpak modules.

1. Connect the cables to the XG700.

Connect the cables to the Xenpak modules (Port 1 - Port 12) on the front of XG700.

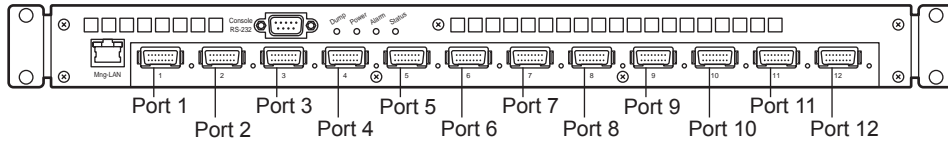

2



Attention

It is necessary that the connectors be fixed in the correct position, in order to protect the connector interface against external influences.

2-3-2 Connecting the power cords

After connecting the peripheral units, connect the XG700 power cords.

WARNING

- Do not touch the power plug with wet hands, as there is a risk of electric shock.
- Do not damage or remodel the power cords, as this may cause electric shock or fire. Placing a heavy object on, pulling, excessively bending, twisting, or overheating a power cord can damage it, and may cause electric shock or fire.
- Do not use the XG700 with a damaged power cord, a damaged power plug, and/or a loose socket. Continued use under these conditions may cause a fire.
- If the power plug pins or socket holes are dusty, clean with a dry cloth. Continued use with a dirty power plug or socket may cause electric shock or fire.

1. Connect the power cords to the XG700.

Insert the plug at the end of the power cord into the power inlet at the rear of the XG700.

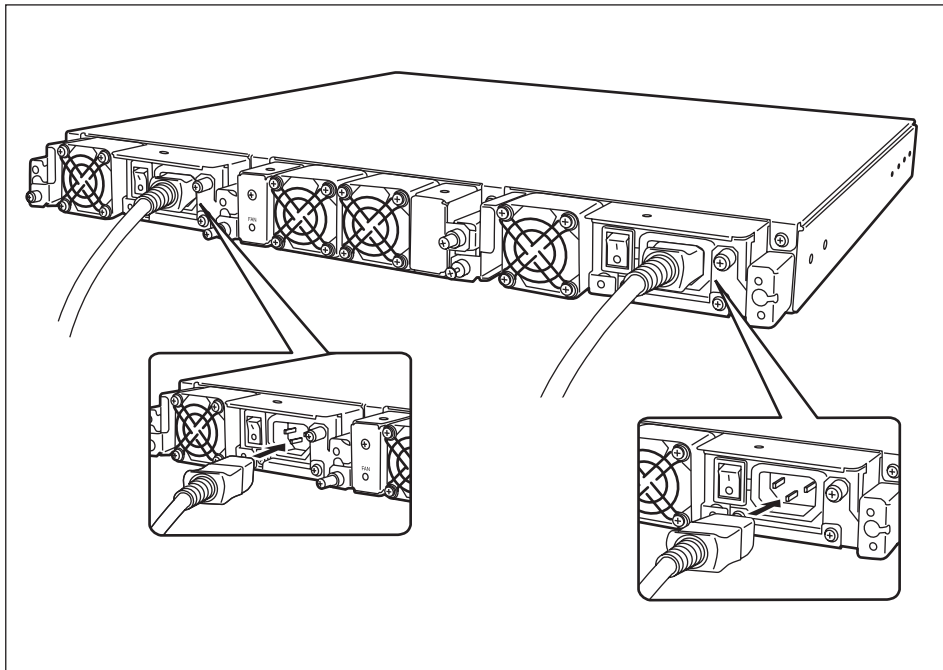

2. Connect the power cord to the power outlet.

Insert the plug at the other end of the power cord into the power strip or wall socket.

⚠WARNING

- Unplug the XG700 during thunder-storms. Continued use under these conditions risks lightning damage to the XG700, and may cause a fire.
 - When you remove a power plug from its outlet, be sure to pull the only power plug itself. Pulling on the power cord itself may expose the cores or break the cord, and cause electric shock or fire.
 - Insert the power plug completely into the power socket. Using the XG700 with a half inserted power plug may cause a fire or damage.
 - If the XG700 is to be left unused for any significant period, remove the power plug from the outlet for safety reasons. Failure to do so may cause a fire or damage.
-

2

2-4 Basic Operation

This section explains the basic operation of XG700.

2-4-1 Turning the XG700 on



CAUTION

Do not move, shock, or vibrate the XG700 while it is on.

1. Turn the power switch to the "on" position by pressing the [|] side.
The Power LED (Green) on the front of the XG700 should turn on. The Alarm LED (Orange) should turn on for a moment, then should turn off. The Status LED (Green) should turn on. If an error occurs while the XG700 is starting up, the Alarm LED (Orange) will start blinking. If two power units are installed, execute the above operation for each.
2. When the system has finished starting up, the Status LED (Green) turns on.

2-4-2 Turning the XG700 off



WARNING

Should the XG700 start giving off heat, smoke, and/or a strange smell, immediately disconnect the power plug from the power outlet. To make this easy, the XG700 should be located close to the power outlet (wall socket or power strip), and the power outlet must be readily accessible. After the power is disconnected, contact the vendor's service department immediately. Continued use of the XG700 may cause an electric shock and fire. Note that in this case, the state of data in transmission is not guaranteed.

1. Execute the "system shutdown" command.
If the firmware has not been updated yet, then execute "system shutdown" from the command line.
 For details of the system shutdown command, refer to the "Command Reference" section in the "XG700 User's Guide".
2. Just turn the power switch to the "off" position by pressing the [○] side.
If two power units are installed, execute the above operation for each.

Troubleshooting

This chapter describes what you should do when your XG700 has problems.

3

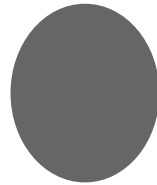

3-1 Start-up Problems	32
3-2 Hardware Problems	33

3-1 Start-up Problems

The following errors may occur when the XG700 is started up. If the cause of the error cannot be resolved, contact the vendor's service department. The following explains some general errors that can occur. Check if any of these match your problem.

The XG700 does not turn on

[Symptom] The power switch is turned on, but the XG700 does not power up.

[Cause] Possible causes:
1 Loose cable, or
2 Hardware failure

[Action]
1 Check that all cables are connected properly, then (if the XG700 still doesn't turn on) or
2 Contact the vendor's service department.

Status LED blinks, but the XG700 does not start up

[Symptom] The XG700 has not started within a few minutes of the power switch being turned on. The Status LED keeps blinking.

[Cause] Probable hardware failure.

[Action] Contact the vendor's service department.

Alarm LED lights, but the XG700 does not start up

[Symptom] The XG700 has not started within a few minutes of the power switch being turned on. The Alarm LED (Orange) lights.

[Cause] Probable hardware failure.

[Action] Contact the vendor's service department.

3-2 Hardware Problems

This section explains what should be done when a fan, temperature, power supply, or memory error occurs. Contact the vendor's service department when the following errors occurred.

Fan error

When a problem is detected with a fan, the front panel Alarm LED lights up in orange, the LED of the fan unit in which the error has occurred lights up in orange, and an error is recorded in the event log. If a fan error occurs, contact the vendor's service department.

Temperature error

When XG700 overheats, the Alarm LED lights up in orange, and a temperature error is recorded in the event log. In this case, check that the ambient and internal rack temperatures are within the specified temperature range, adjust them if they are not and try turning the XG700 back on. When error occurs even though the ambient rack temperatures are acceptable, turn the XG700 off and contact the vendor's service department.

Voltage error

When a voltage problem is detected, the Alarm LED lights up in orange, and an error is recorded in the event log. In this case, turn the XG700 off and contact the vendor's service department.

Power supply error

When a power supply problem is detected, the Alarm LED lights up in orange, the power fail LED of the power unit in which the error has occurred lights up in orange, and an error is recorded in the event log. Verify that the AC power supply for the failed power unit is normal and the cable has not come loose.

If some other reason has caused the power fail LED to light up, contact the vendor's service department.

Memory error

Startup diagnostic tests are run after the power is turned. If a memory error is detected at this stage, the Alarm LED blinks, but an event log entry is not created. If a memory error is detected during operation, an event log entry is created and the system automatically reboots. Note that whether or not a memory error results in an event log entry is a matter of timing.

If memory errors occur repeatedly, contact the vendor's service department.



Appendix

This appendix explains XG700 specifications.

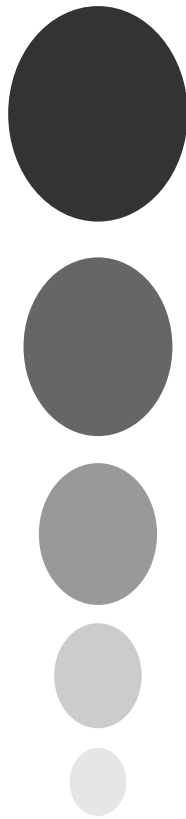

Appendix-A Specifications	36
A.1 Product Specifications	36
A.2 Installation Specifications.....	36

Appendix-A

This section details the specifications of XG700.

A.1 Product Specifications

The product specifications of the XG700 are as follows:

Items		Overview
10 Gigabit ports	Port1 - Port12	IEEE802.3ak compliant 10 Gigabit Ethernet port X 12
Serial Port		RS-232C D-SUB9 X 1 Console connection port
Management LAN	Mng-LAN	10BASE-T/100BASE-TX X 1
Indicators	LED	Power (Green), Alarm (Orange), Status (Green), Rear fan, Power supply units

A.2 Installation Specifications

The installation specifications of the XG700 are as follows:

Items		Specifications
Dimensions (Excluding protrusions)	Width	440mm
	Depth	442mm
	Height	42.7mm
Maximum weight		12 kg
Power Cord		for 3-pin socket (grounded)
Power source	Voltage	AC100 (-10%) - 240V (+10%)
	Phase	Single-phase
	Frequency	50 or 60Hz (+2% / -4%)
Input current		100 - 240 V 0.60 - 0.34 A/Input
Ambient temperature	XG700 on	+5 - +40°C (Inlet temperature)
	XG700 off	0 - +50°C (Inlet temperature)
Ambient humidity	XG700 on	20 - 80%RH (Non-condensing)
	XG700 off	8 - 90%RH (Non-condensing)
Temperature gradient	XG700 on	15°C/hr or less (Non-condensing)
	XG700 off	
Ambient dust		0.15mg/m ³ or less
Ambient noise		55dB or less
Electromagnetic compatibility		FCC Class A CE Marking
Service area	Front	800mm
	Rear	800mm
Installation		1U in a 19-inch rack

XG700 Hardware Guide

P3N1-E041-01EN

Date of issue: September 2005

Issuing authority: PFU LIMITED

Printed in Japan

-
- Contents of this manual are not to be reproduced without permission from PFU.
 - The contents of this manual may be updated without notice.
 - PFU assumes no liability for damages to third party copyrights or other rights arising from the use of any information in this manual.
 - Manuals with missing or wrongly collated pages will be replaced free of charge.
-