

Owner's Manual

Makita

Wet/Dry Vacuum

Model XSV10 Type 2

FOR COMMERCIAL/INDUSTRIAL USE

Makita Limited One Year Warranty

Every Makita tool is thoroughly inspected and tested before leaving the factory. It is warranted to be free of defects from workmanship and materials for the period of ONE YEAR from the date of original purchase. Should any trouble develop during this one-year period, return the COMPLETE tool, freight prepaid, to one of Makita's Factory or Authorized Service Centers. If inspection shows the trouble is caused by defective workmanship or material, Makita will repair (or at our option, replace) without charge.

This Warranty does not apply where:

- repairs have been made or attempted by others
- repairs are required because of normal wear and tear
- The tool has been abused, misused or improperly maintained
- alterations have been made to the tool.

IN NO EVENT SHALL MAKITA BE LIABLE FOR ANY INDIRECT, INCIDENTAL OR CONSEQUENTIAL DAMAGES FROM THE SALE OR USE OF THE PRODUCT. THIS DISCLAIMER APPLIES BOTH DURING AND AFTER THE TERM OF THIS WARRANTY.

MAKITA DISCLAIMS LIABILITY FOR ANY IMPLIED WARRANTIES, INCLUDING IMPLIED WARRANTIES OF "MERCHANTABILITY" AND "FITNESS FOR A SPECIFIC PURPOSE," AFTER THE ONE-YEAR TERM OF THIS WARRANTY.

This Warranty gives you specific legal rights, and you may also have other rights which vary from state to state. Some states do not allow the exclusion or limitation of incidental or consequential damages, so the above limitation or exclusion may not apply to you. Some states do not allow limitation on how long an implied warranty lasts, so the above limitation may not apply to you.

Attention:

Read all safety rules carefully before attempting to operate. Retain for future reference.
UL Listed.

⚠ DANGER

Never operate this unit when flammable materials or vapors are present because electrical devices produce arcs or sparks that can cause a fire or explosion.

**PLEASE
REVIEW
Before Operating
Vac**



Model XSV10 Type 2

This Makita Industrial vacuum cleaner is designed for both wet and dry applications. This model includes a stainless steel tank assembly, 1.7 HP (Peak) two-stage by-pass motor and an 18' power cord. Standard accessories include a 12' x 1 1/2" crushproof hose, 2-piece - 1 1/2" chrome plated interlocking extension wands, 14" metal master nozzle, 14" brush insert, 14" squeegee insert, cartridge filter, and heavy-duty 3-wheel dolly for easy mobility. Each model incorporates an automatic shut-off water level float.

Specifications

Capacity	
XSV-10 Type 2	10 gallons
Intake size	2 1/2" dia.
Volume flow rate (2 1/2" Orifice)	100 CFM
Static Pressure	80" water
Rated current drain	6.5 Amps
Power supply required	120Volts, 60Hz
Cord length	18 ft.
Approval	UL Listed

IMPORTANT SAFETY INSTRUCTIONS

When using an electrical appliance, basic precautions should always be followed, including the following: **READ ALL INSTRUCTIONS BEFORE USING THIS APPLIANCE.**

WARNING – TO REDUCE THE RISK OF FIRE, ELECTRIC SHOCK OR INJURY:

1. Do not leave appliance when plugged in. Unplug from outlet when not in use and before servicing. Connect to a properly grounded outlet only. See Grounding Instructions.
2. Do not expose to rain—store indoors.
3. Do not allow to be used as a toy. Close attention is necessary when used by or near children.
4. Use only as described in this manual. Use only Manufacturer's recommended attachments.
5. Do not use with damaged cord or plug. If appliance is not working as it should, has been dropped, damaged, left outdoors or dropped into water, return it to a service center.
6. Do not pull or carry by cord, use cord as a handle, close a door on cord or pull cord around sharp edges or corners. Do not run appliance over cord. Keep cord away from heated surfaces.
7. Do not unplug by pulling on cord. To unplug, grasp the plug; not the cord.
8. Do not handle plug or appliance with wet hands.
9. Do not put any object into openings. Do not use with any openings blocked; keep free of dust, lint, hair and anything that may reduce air flow.
10. Keep hair, loose clothing, fingers and all parts of body away from openings and moving parts.
11. Do not pick up anything that is burning or smoking, such as cigarettes, matches or hot ashes.
12. Do not use without dust bag and/or filters in place.
13. Turn off all controls before unplugging.
14. Use extra care when cleaning on stairs.
15. Do not use to pick up flammable or combustible liquids such as gasoline or use in areas where they may be present.
16. Do not use your cleaner as a sprayer of flammable liquids such as oil base paints, lacquers, household cleaners, etc.
17. Do not vacuum toxic, carcinogenic, combustible or other hazardous materials such as asbestos, arsenic, barium, beryllium, lead, pesticides or other health endangering materials. Specially designed units are available for these purposes.
18. Do not pick up wood or coal ash; soot, cement, plaster or drywall dust without full cloth filter or collection filter bag in place. These are very fine particles that may pass through the foam and disc filters and affect the performance of the motor or be exhausted back into the air. Full cloth filters and additional collection filter bags are available (see enclosed order form).
19. Don't leave the cord lying on the floor once you have finished the cleaning job. It can become a tripping hazard.
20. Use special care when emptying heavily loaded tanks.
21. To avoid spontaneous combustion, empty tank after each use.
22. The operation of a utility vac can result in foreign objects being blown into eyes, which can result in eye damage. Always wear safety goggles when operating vacuum.
23. **STAY ALERT.** Watch what you are doing and use common sense. Do not use vacuum cleaner when you are tired, distracted or under the influence of drugs, alcohol or medication causing diminished control.

SAVE THESE INSTRUCTIONS

GROUNDING INSTRUCTIONS

This cleaner must be grounded. If it should malfunction or breakdown, grounding provides a path of least resistance for electric current to reduce the risk of electric shock. This appliance is equipped with a cord having an equipment-grounding conductor and grounding plug. The plug must be inserted into an appropriate outlet that is properly installed and grounded in accordance with all local codes and ordinances.

WARNING – IMPROPER CONNECTION OF THE EQUIPMENT-GROUNDING CONDUCTOR CAN RESULT IN A RISK OF ELECTRIC SHOCK. CHECK WITH A QUALIFIED ELECTRICIAN OR SERVICE PERSON IF YOU ARE IN DOUBT AS TO WHETHER THE OUTLET IS PROPERLY GROUNDED. DO NOT MODIFY THE PLUG PROVIDED WITH THE APPLIANCE – IF IT WILL NOT FIT THE OUTLET, HAVE A PROPER OUTLET INSTALLED BY A QUALIFIED ELECTRICIAN.

This cleaner is for use on a nominal 120-volt circuit, and has a grounded plug that looks like

the plug illustrated in sketch A. A temporary adapter that looks like the adapter illustrated in sketches B and C may be used to connect this plug to a 2-pole receptacle as shown in sketch B if a properly grounded outlet is not available. The temporary adapter should be used only until a properly grounded outlet (sketch A) can be installed by a qualified electrician. The green colored rigid ear, lug or the like extending from the adapter must be connected to a permanent ground such as a properly grounded outlet box cover. Whenever the adapter is used, it must be held in place by a metal screw.

NOTE: IN CANADA, THE USE OF A TEMPORARY ADAPTER IS NOT PERMITTED BY THE CANADIAN ELECTRICAL CODE.

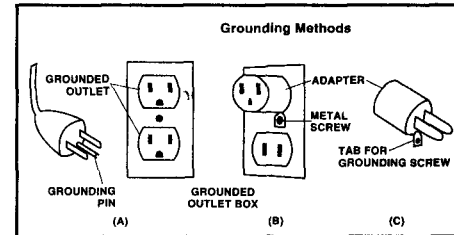

EXTENSION CORDS

When using the appliance at a distance where an extension cord becomes necessary, a 3-conductor grounding cord of adequate size must be used for safety, and to prevent loss of power and overheating. Use the table below to determine A.W.G. wire size required. Before using appliance, inspect power cord for loose or exposed wires and damaged insulation. Make any needed repairs or replacements before using your appliance. Use only three-wire outdoor extension cords which have three-prong grounding-type plugs and three-pole receptacles which accept the extension cord's plug. When vacuuming liquids, be sure the extension cord connection does not come in contact with the liquid.

NOTE: STATIC SHOCKS ARE COMMON IN DRY AREAS OR WHEN THE RELATIVE HUMIDITY OF THE AIR IS LOW. THIS IS ONLY TEMPORARY AND DOES NOT AFFECT THE USE OF THE APPLIANCE. TO REDUCE THE FREQUENCY OF STATIC SHOCKS IN YOUR HOME, THE BEST REMEDY IS TO ADD MOISTURE TO THE AIR WITH A CONSOLE OR INSTALLED HUMIDIFIER.

Volts	Total length of cord in feet			
	25	50	100	150
Ampere Rating More Than	AWG			
Not More Than				
0-6	18	16	16	14
6-10	18	16	14	12
10-12	16	16	14	12
12-16	14	12	Not recommended	

UNPACKING AND SETUP

Your Makita Industrial Vac comes to you completely assembled. Simply remove the machine from the carton after unpacking the accessories. (Note that some accessories may have been

packed in the tank.) However, it is necessary to attach the tank handles and assemble the heavy-duty vac dolly. (Please see the instructions in this manual)

OPERATION

Caution: Before plugging vacuum into outlet, make sure outlet voltage is same as voltage rating given on vacuum nameplate.

1. Insert the large end of the hose into the side inlet fitting.
2. Attach cleaning tools to the other end of the hose.
3. Prepare the unit for Dry Pick-Up or Wet Pick-Up as follows:

A. Dry Pick-Up Operation

! WARNING – ALWAYS DISCONNECT THE PLUG FROM THE WALL OUTLET BEFORE REMOVING THE TANK COVER. TO PICK UP DUST AND DRY MATERIAL, YOU MUST ADD A CARTRIDGE FILTER TO ENSURE PROPER FILTRATION. ENSURE CARTRIDGE FILTER IS COMPLETELY DRY BEFORE OPERATION. BE SURE THAT CARTRIDGE FILTER IS IN POSITION OVER THE FILTER CAGE COVERING ALL OPENINGS. SEE THE ENCLOSED CARTRIDGE FILTER MAINTENANCE SHEET FOR INSTALLATION, OPERA-

TION AND CLEANING OF THE CARTRIDGE FILTER.

! CAUTION – KEEP FILTERS CLEAN.

Efficiency of the vacuum is largely dependent on the cartridge filter. A clogged filter can cause overheating and possibly damage the cleaner. Filters should be removed periodically and cleaned and be replaced as required. Should the cartridge filter be punctured — it must be replaced.

B. Wet Pick-Up Operation

! WARNING: ALWAYS DISCONNECT THE PLUG FROM THE WALL OUTLET BEFORE REMOVING THE TANK COVER. THE CARTRIDGE FILTER CAN BE USED FOR BOTH WET AND DRY PICK-UP.

NOTE: BE SURE CARTRIDGE FILTER IS CLEAN PRIOR TO WET PICK-UP.

MAINTENANCE

! WARNING – BE SURE TO DISCONNECT POWER SUPPLY BEFORE ATTEMPTING TO SERVICE OR REMOVE ANY COMPONENTS.

SHOULD SERVICING BE REQUIRED, REFER TO THE REPLACEMENT PARTS ILLUSTRATION FOR PURPOSE OF DISASSEMBLY AND REASSEMBLY. REPLACE ALL WORN OR DAMAGED PARTS.

LUBRICATION

No lubrication is necessary as the motor is equipped with lifetime lubricated bearings.

! DANGER – THIS EQUIPMENT INCORPORATES PARTS SUCH AS SWITCHES, MOTORS, OR THE LIKE, THAT TEND TO PRODUCE ARCS OR SPARKS, THAT CAN CAUSE AN EXPLOSION. WHEN LOCATED IN GASOLINE-DISPENSING OR SERVICE STATIONS INSTALL AND USE AT LEAST 20 FEET HORIZONTALLY FROM THE EXTERIOR ENCLOSURE OF ANY DISPENSING PUMP AND AT LEAST 18 INCHES ABOVE A DRIVEWAY OR GROUND LEVEL.

! WARNING – IF ANY OF THE MOTOR HOUSING PARTS SHOULD BECOME DETACHED OR BROKEN, EXPOSING THE MOTOR OR ANY OTHER ELECTRICAL COMPONENTS, OPERATION SHOULD BE DISCONTINUED IMMEDIATELY TO AVOID PERSONAL INJURY OR FURTHER DAMAGE TO THE VACUUM. REPAIRS SHOULD BE MADE BEFORE USING THE VACUUM.

EMPTYING LIQUID WASTES FROM THE TANK

! CAUTION – USE SPECIAL CARE WHEN EMPTYING HEAVILY LOADED TANKS. YOUR MAKITA WET/DRY VAC MAY BE EMPTIED OF LIQUID WASTE BY REMOVING THE TANK COVER. TO EMPT, STOP THE MOTOR AND REMOVE THE PLUG FROM THE WALL RECEPTACLE. REMOVE THE TANK COVER AND DEPOSIT THE LIQUID WASTE CONTENTS INTO A SUITABLE DRAIN. AFTER THE TANK IS EMPTY, RETURN THE COVER TO ITS ORIGINAL POSITION. TO CONTINUE USE, PLUG THE CORD INTO THE WALL RECEPTACLE AND START THE MOTOR.

NOTE: WET PICK-UP ACCESSORIES SHOULD BE WASHED PERIODICALLY, ESPECIALLY AFTER PICKING UP WET, STICKY ACCIDENTS. THIS CAN BE ACCOMPLISHED WITH A WARM SOLUTION OF SOAP AND WATER. AFTER COMPLETING A WET PICK-UP, RAISE THE HOSE ABOVE THE CLEANER TO PERMIT ANY LIQUID IN THE HOSE TO DRAIN INTO THE TANK BEFORE SHUTTING OFF VAC. THE INTERIOR OF THE TANK SHOULD ALSO BE PERIODICALLY CLEANED.

AUTOMATIC SHUT-OFF

This cleaner is equipped with an automatic shut-off that operates when picking up liquids. As the level of the liquid rises, an internal float rises until it seats itself against a seal at the intake of the motor, shutting off suction. When this happens, the motor will develop a higher than normal pitch noise. To continue use, empty the liquid waste from the tank as outlined in the previous paragraph.

NOTE: IF ACCIDENTLY TIPPED OVER, THE VACUUM COULD LOSE ITS SUCTION. IF THIS OCCURS, PLACE VAC IN

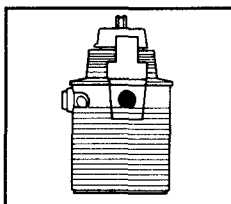

UPRIGHT POSITION AND TURN SWITCH OFF. THIS WILL ALLOW THE FLOAT TO RETURN TO ITS NORMAL POSITION, AND YOU WILL BE ABLE TO CONTINUE OPERATION.

Using Your Master Nozzle

Your wet/dry vacuum comes equipped with a revolution in vacuum cleaners. ONE NOZZLE DOES IT ALL!

The brush and squeegee inserts can be inserted in the nozzle by aligning the insert with the opening in the nozzle and apply pressure until the insert is firmly in place

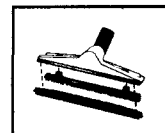

STORAGE

Before storing your cleaner, the tank should be emptied and cleaned. The power cord can be wound around the housing of the unit for convenience. Accessories may be stored in the tank

while those that cannot be stored in the tank should be kept in the same area as the cleaner so they can be readily available. The cleaner should be stored indoors.

TROUBLESHOOTING CHART

Symptom	Possible Cause(s)	Corrective Action
Vacuum will not start	1. Defective switch 2. Defective motor	1. Replace switch 2. Replace motor
Dust blowing	Filters not functional	Clean or replace filters
Loss of vacuum	1. Loose hose connection 2. Filter clogged 3. Full tank 4. Hole in hose	1. Tighten hose connection 2. Clean or replace filter 3. Empty machine 4. Replace hose

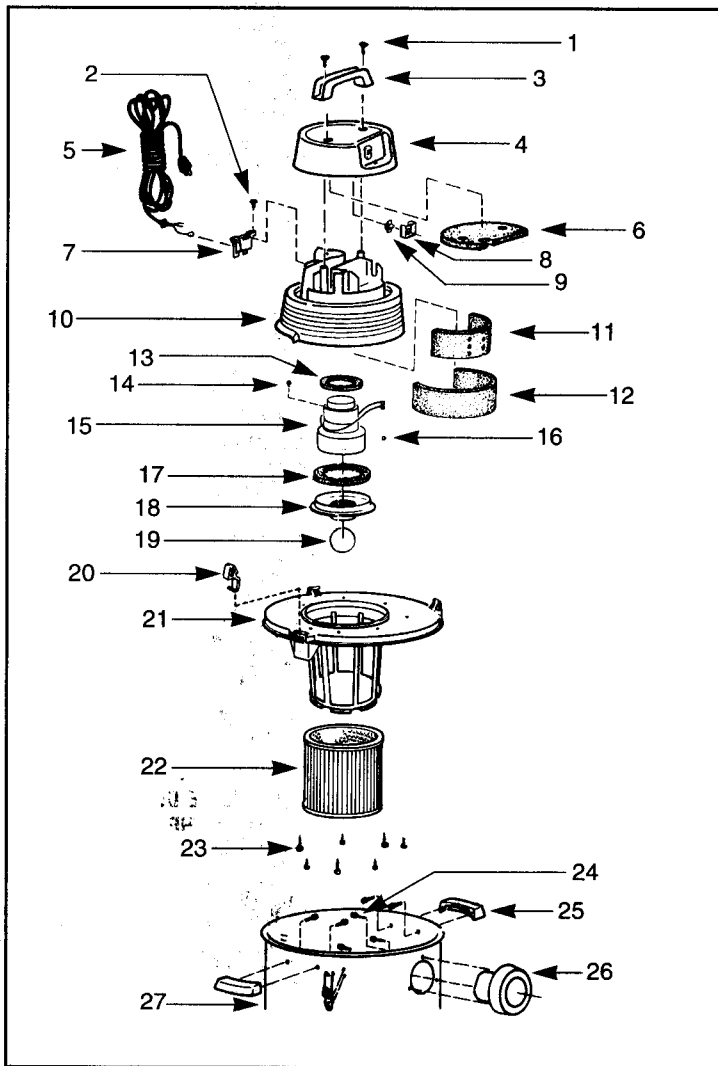

ITEM	DESCRIPTION	NO. USED
1	Screw Truss Hd 1/4" x 3/4" Type AB	2*
2	Screw #8 x 1/2 Ph Pan Hd Type AB	1*
3	Handle	1
4	Motor Housing Cover Assembly	1
5	Cord	1
6	Foam Insert Cover	1
7	Cord Retainer	1
8	Switch Box	1
9	Switch	1
10	Motor Housing	1
11	Foam Motor Housing - Inner	1
12	Foam Motor Housing - Outer	1
13	Gasket - Upper Motor	1
14	Ground Screw #10-24 x 1/2" Type F	1*
15	Motor	1
16	Wire Nut	1*
17	Gasket - Lower Motor	1
18	Motor Mounting Plate	1
19	Ball Float	1
20	Lid Latch	3
21	Lid and Cage	1
22	Cartridge Filter	1
23	Screw #10 x 3/4" SL HX HD WASH AB	7*
24	Screw #10 x 3/8" Hex Head	2*
25	Handle Package	1
26	Inlet Fitting	1
27	Tank Assembly	1

* Standard hardware item, purchase locally.

Printed in USA.

Dolly Assembly

- Remove head from tank and place tank upside down on a flat surface.
- Place wheels on rear frame/axle assembly with extended hub towards dolly frame and place cap nut on axle and secure with hammer.
- Insert caster socket into front frame and secure with philips head screw.
- Place groove in front frame into lip of tank and position so frame is directly above inlet.
- Position grooves of rear frame on lip of tank and align so rear and front frames engage.
- Secure dolly frame to tank by placing hex head screws up through holes in dolly frame. Insure head of screw is fully recessed in area provided. After machine screw is inserted, tighten with 1/4" flat washer and hex nut. (See Drawing A).
- Insert caster in caster socket and apply downward pressure until caster snaps into place.
- Place tank upright on dolly.

ITEM	DESCRIPTION	NO. USED
1	Cap Nut	2
2	Axle	1
3	Wheel	2
4	Rear Frame	1
5	Caster Socket	1
6	Front Frame	1
7	Screw #8 x 1/2" PH Truss Type A	1*
8	Screw 1/4-20 x 3/4 Lg. Hex Hd.	6*
9	Flatwasher 1/4"	6*
10	Hex Nut 1/4-20	6*
11	Caster	1
12	Carriage Handle	1

* Standard hardware item, purchase locally.

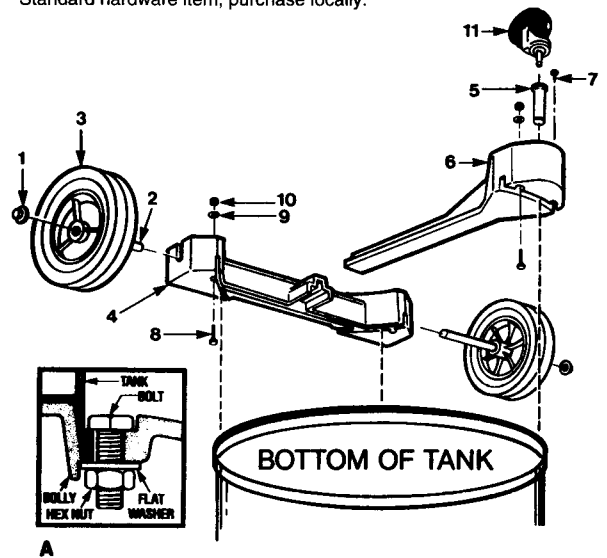

Your Makita Wet/Dry Vac includes a metal carriage handle for ease in transporting the vacuum. Place metal handle between tank and plastic side handles, and fasten tightly with screws provided. Be sure to spread ends of carriage handle when assembling to prevent damage to drum.

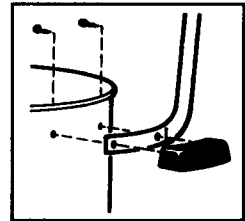

MAKITA FACTORY OR AUTHORIZED SERVICE CENTERS

If your Makita Wet/Dry Vac ever needs repair or maintenance during the warranty period or any time thereafter, there are Factory and Authorized Service Centers located across the country. (Please see the accompanying list, current Makita catalog or consult your local yellow pages.)

Do not attempt to service your Makita Wet/Dry Vac beyond that described in the Owner's Manual. For all other servicing, please refer to a qualified Makita Service Center.

Makita U.S.A., Inc.
14930 Northam Street
La Mirada, CA 90638-5753

87510-27