

# INTERCONTINENTAL COLLECTION BY VERMONT CASTINGS

## Direct Vent Model: DVR28IN

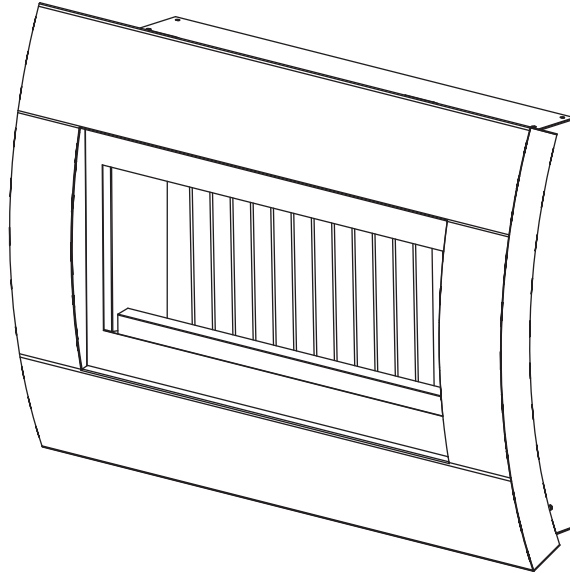

### Installation Instructions and Homeowner's Manual

#### INSTALLER/CONSUMER SAFETY INFORMATION

PLEASE READ THIS MANUAL BEFORE INSTALLING AND USING APPLIANCE

#### **WARNING!**

**IF THE INFORMATION IN THIS MANUAL IS NOT FOLLOWED EXACTLY, A FIRE OR EXPLOSION MAY RESULT CAUSING PROPERTY DAMAGE, PERSONAL INJURY OR LOSS OF LIFE.**

#### **WHAT TO DO IF YOU SMELL GAS:**

- Do not try to light any appliance.
- Do not touch any electric switch; do not use any phone in your building.
- Immediately call your gas supplier from your neighbor's phone. Follow the gas suppliers instructions.
- If you cannot reach your gas supplier call the fire department.

#### **FOR YOUR SAFETY**

**Installation and service must be performed by a qualified installer, service agency or the gas supplier.**

**DO NOT STORE OR USE GASOLINE OR OTHER FLAMMABLE VAPORS AND LIQUIDS IN THE VICINITY OF THIS OR ANY OTHER APPLIANCE.**

**INSTALLER: Leave this manual with the appliance    CONSUMER: Retain this manual for future reference.**

# Table of Contents

**PLEASE READ THE INSTALLATION & OPERATING INSTRUCTIONS  
BEFORE USING APPLIANCE.**

Thank you and congratulations on your purchase of a CFM Corporation fireplace.

**IMPORTANT:** Read all instructions and warnings carefully before starting installation.

Failure to follow these instructions fully may result in a possible fire hazard and will void the warranty.

## **Installation & Operating Instructions**

Important Curing/Burning Instructions .....	3
Fireplace Dimensions .....	4
Minimum Clearance Illustrations .....	4
Firestop Framing .....	4
Locating Your Fireplace .....	5
Clearance to Combustibles .....	5
Installation Instructions .....	5
Mounting the Fireplace .....	5
Gas Specifications, Gas Inlet and Manifold Pressures .....	6
High Elevations .....	6
Remote ON/OFF Hi/Lo Wall Mounted Transmitter .....	6
Gas Line Installation .....	6
DVR28 Wiring Diagram .....	7
Restrictor Plate Installation .....	7

## **General Venting Information**

General Venting .....	8
General Venting - Termination Location .....	9
General Venting - Assembling Vent Pipes .....	10
How to Use the Vent Graph .....	11
Rear Wall Venting Applications and Installation .....	11
Vertical Side Wall Venting Applications and Installation .....	13
Below Grade Installation .....	14
Vertical Through-the-Roof Applications and Installation .....	14
Venting Components .....	17

## **Operating Instructions**

Glass Information .....	18
Window Frame Assembly Removal .....	18
Glass Cleaning .....	18
Removal and Re-fitting of Curve Face .....	18
Flame & Temperature Adjustment .....	19
Flame Characteristics .....	19
Inspecting the Venting System .....	19
Lighting & Operating Instructions .....	20
Troubleshooting .....	21

## **Maintenance**

Cleaning the Standing Pilot Control System .....	24
--	----

## **Replacement Parts** .....

## **Accessories**

Curve Face Kit .....	26
Screen Door Kit .....	26

## **Warranty** .....

## **Energuide** .....

## Installation & Operating Instructions

This gas appliance must be installed by a qualified installer, preferably NFI or WETT (Canada) certified, in accordance with local building codes and with current CSA-B149.1 Installation codes for Gas Burning Appliances and Equipment. For USA Installations follow local codes and/or the current National Fuel Gas Code. ANSI Z223.1/NFPA 54.

**In the Commonwealth of Massachusetts, all gas fitting and installation of this heater shall only be done by a licensed gas fitter or licensed plumber.**

FOR SAFE INSTALLATION AND OPERATION PLEASE NOTE THE FOLLOWING:

1. This fireplace gives off high temperatures and should be located out of high traffic areas and away from furniture and draperies.
2. Children and adults should be alerted to the hazards of high surface temperatures of this fireplace and should stay away to avoid burns or ignition of clothing.
3. **CAUTION: Due to high glass surface temperature children should be carefully supervised when in the same room as fireplace.**
4. Under no circumstances should this fireplace be modified. Parts removed for servicing should be replaced prior to operating this fireplace again.
5. A professional service person should be contacted to inspect this fireplace annually. Make it a practice to have all of your gas fireplaces checked annually. More frequent cleaning may be required due to excess lint and dust from carpeting, bedding material, etc.
6. Control compartments, burners and air passages in this fireplace should be kept clean and free of dust and lint. Make sure the gas valve and pilot light are turned off before you attempt to clean this fireplace.
7. The venting system (chimney) of this fireplace should be checked at least once a year and if needed your venting system should be cleaned.
8. Keep the area around your fireplace clear of combustible materials, gasoline and other flammable vapor and liquids. This fireplace should not be used as a drying rack for clothing, nor should Christmas stockings or decorations be hung on or around the fireplace.
9. Under no circumstances should any solid fuels (wood, coal, paper or cardboard etc.) be used in this fireplace.
10. The flow of combustion and ventilation air must not be obstructed in any way.
11. When fireplace is installed directly on carpeting, vinyl tile or any combustible material other than wood, the fireplace must be installed on a metal or wood panel extending the full width and depth of the fireplace.
12. This fireplace requires adequate ventilation and combustion air to operate properly.

13. This fireplace must not be connected to a chimney flue serving a separate solid fuel burning fireplace.
14. When the fireplace is not in use it is recommended that the gas valve be left in the **OFF** position.

**WARNING: Check with your electronics manufacturer before installing a television or other electronic device above this fireplace.**

**DVR28IN  
Certified To**

**ANSI Z21.88-2005 / CSA 2.33-2005  
Vented Gas Fireplace Heaters**

This appliance may be installed in an aftermarket permanently located, manufactured home or mobile home, where not prohibited by local codes.

This appliance is only for use with the type of gas indicated on the rating plate. This appliance is not convertible for use with other gases, unless a certified kit is used.

### **IMPORTANT:**

#### **PLEASE REVIEW THE FOLLOWING CAREFULLY**

Remove any plastic from trim parts before turning the fireplace ON.

It is normal for fireplaces fabricated of steel to give off some expansion and/or contraction noises during the start up or cool down cycle. Similar noises are found with your furnace heat exchanger or car engine.

It is not unusual for your gas fireplace to give off some odor the first time it is burned. This is due to the curing of the paint and any undetected oil from the manufacturing process.

**Please ensure that your room is well ventilated - open all windows.**

It is recommended that you burn your fireplace for at least ten (10) hours the first time you use it. If the optional fan kit has been installed, place the fan switch in the "OFF" position during this time.

**Proposition 65 Warning:** Fuels used in gas, woodburning or oil fired appliances, and the products of combustion of such fuels, contain chemicals known to the State of California to cause cancer, birth defects and other reproductive harm. California Health & Safety Code Sec. 25249.6

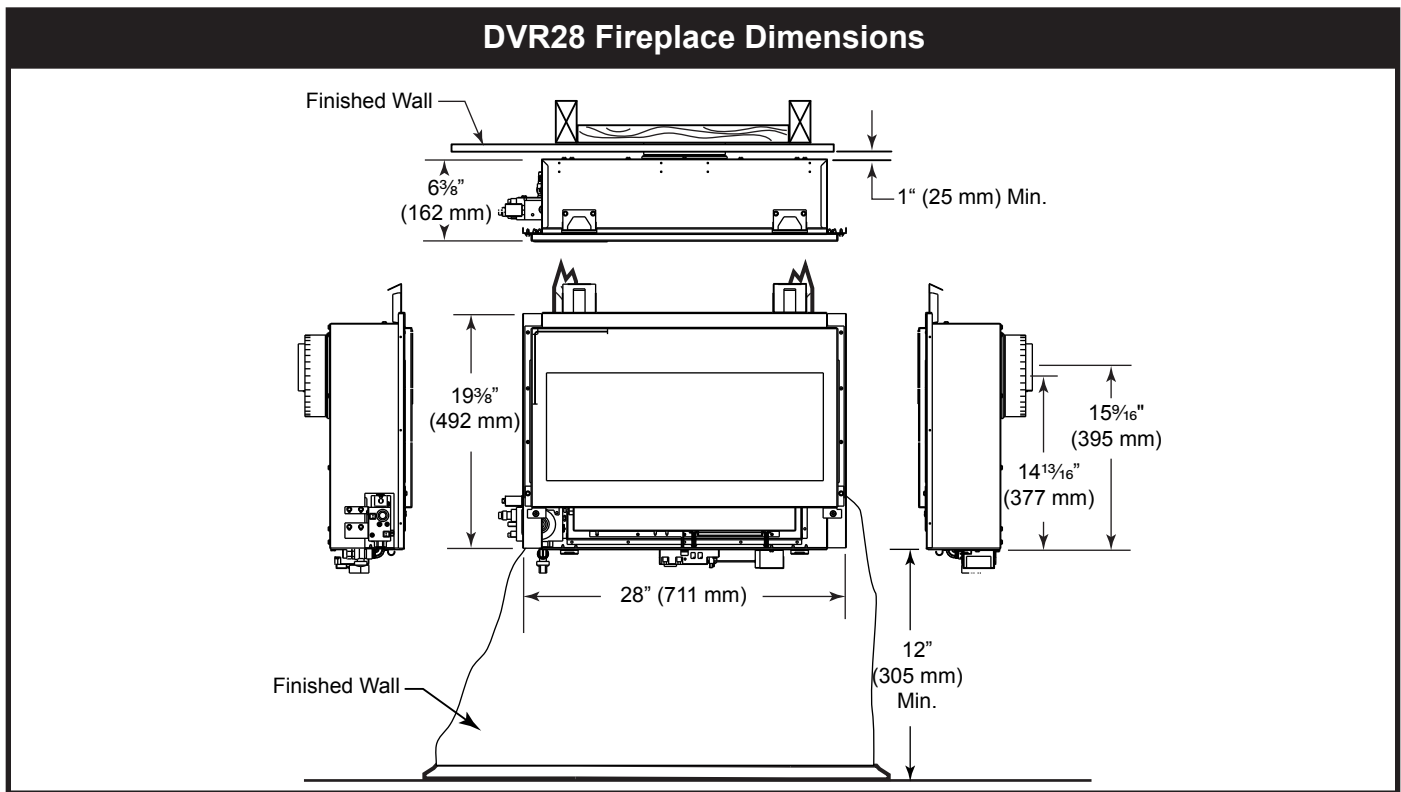

Fig. 1 Fireplace specifications and framing dimensions.

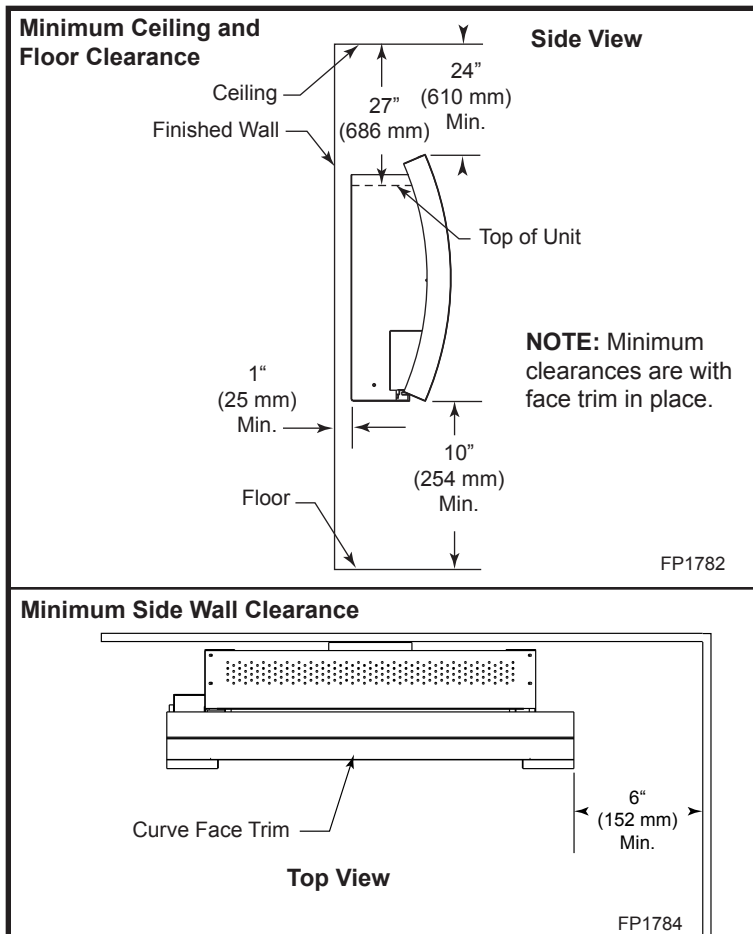

Fig. 2 Minimum clearances.

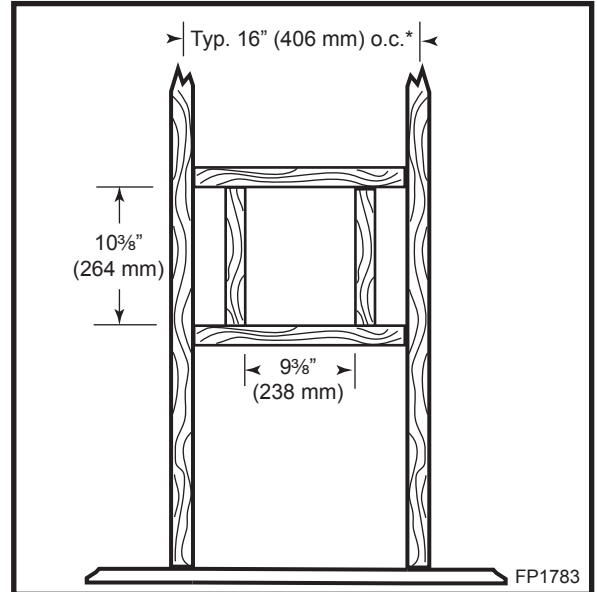

Fig. 3 Firestop framing.

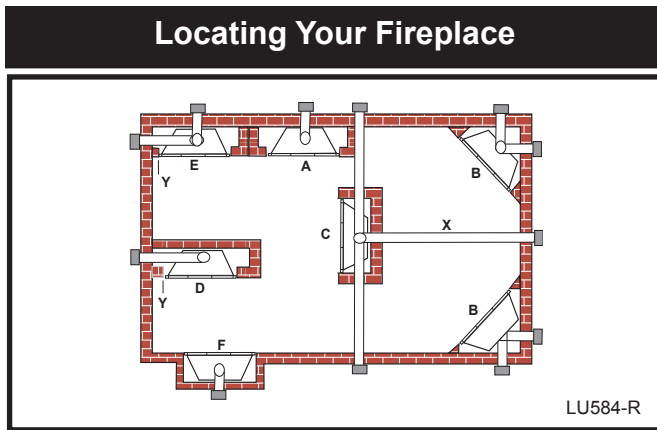

Fig. 4 Locate gas fireplace.

- A) Flat on wall    B) Cross corner    C) \*\*Island  
 D) \*Room divider    E) \*Flat on wall corner    F) Chase installation  
 Y) 6" minimum

**NOTE:** (Fig. 4)

\*\* Island (C) and Room Divider (D) installation is possible as long as the horizontal portion of the vent system (X) does not exceed 20' (610 cm). See details in Venting Section.

\* When you install your fireplace in (D) Room divider or (E) Flat on wall corner positions (Y), a minimum of 6" (153 mm) clearance must be maintained from the perpendicular wall and the front side edge of the fireplace. Refer to (Y) in Figure 4.

### Clearance to Combustibles

Front of Unit to Combustibles .....36" (914 mm)

**Appliance**

- Top of Unit to Ceiling .....27" (686 mm)
- Top of Face Trim to Ceiling ..... 24" (610 mm) Min.
- Bottom of Unit to Floor ..... 12" (305 mm)
- Side of Unit to Sidewall ..... 10½" (267 mm)
- Back .....1" (25 mm)

**Venting**

- Concentric sections of DV Vent .....1" (25 mm)
- Nonconcentric sections of DV Vent

  - Sides and Bottom .....1" (25 mm)
  - Top .....2" (51 mm)

### Installation Instructions

#### Preparation



**Check fireplace to make sure it is levelled and properly positioned.**

1. Choose the location for the fireplace. Maintain proper height and clearances.
2. Make sure framing is 16" (406 mm) o.c. for placement of wall mount brackets pre-drilled holes. If framing is not 16" o.c., the installer can drill new holes in wall mounting brackets to align with existing framing dimensions.

3. Make sure framing for firestop is correct. **NOTE:** Firestop is for combustible walls. Refer to firestop framing instructions on Pages 4 and 12, Figures 4 and 17.
4. Plumb for gas connection. Refer to Gas Line Installation on Page 6.
5. Finish wall as desired.



**CAUTION:** If wall is finished with combustible materials, be sure to install firestop according to instructions.

### Mounting the Fireplace



**CAUTION: DO NOT** place fireplace on floor or hard surface with bottom side down, components could be damaged.

1. The DVR28 comes with a wall mount bracket to secure the fireplace to the wall. Standoffs on the back of the bracket allow for proper clearances to combustibles. (Fig. 5)

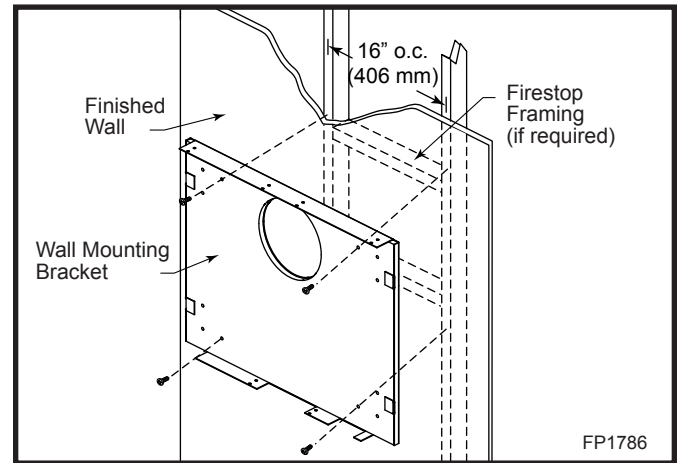

Fig. 5 Secure wall mounting bracket in desired location.

2. Align pipe clearance hole in wall mounting bracket with through-the-wall clearance opening on noncombustible wall or through firestop opening on combustible walls.
3. Make sure wall mount bracket is level. Secure to framing studs using mounting screws supplied. Ensure framing is 16" (406 mm) o.c. to accommodate mounting bracket.
4. Align the top and bottom mounting holes of the fireplace with the top and bottom holes of the mounting bracket. Secure fireplace to mounting bracket using sheet metal screws supplied. (Fig. 6)



**CAUTION:** Be careful to avoid damaging the electric components located on the bottom of the fireplace when securing to the mounting bracket.

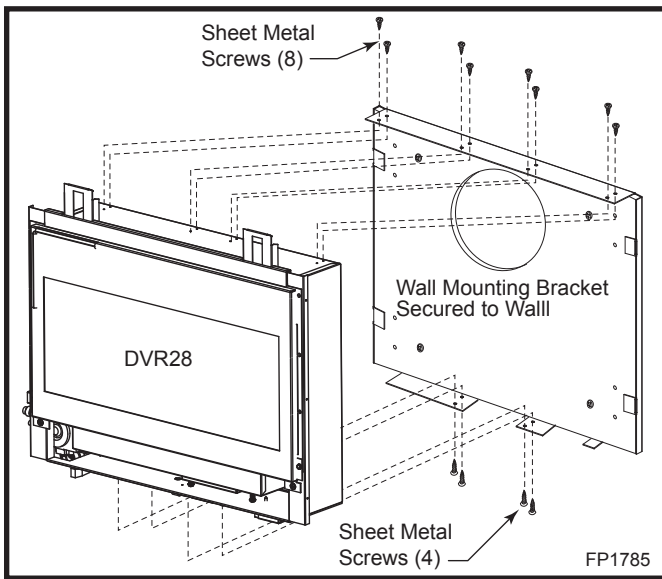

Fig. 6 Secure fireplace to wall mounting bracket.

### Gas Specifications

			Max. Input	Min. Input	Air Shutter
Model	Fuel	Gas Control	BTU/h	BTU/h	Setting
DVR28IN	Nat.	Millivolt Hi/Lo	18,500	16,500	1/8" open on sides

### Gas Inlet and Manifold Pressures

		Natural
Inlet Minimum		5.5" w.c.
Inlet Maximum		14.0" w.c.
Manifold Pressure		3.5" w.c.

### High Elevations

Input ratings are shown in BTU per hour and are certified without deration for elevations up to 4,500 feet (1,370m) above sea level.

For elevations above 4,500 feet (1,370m) in USA, installations must be in accordance with the current ANSI Z223.1/NFPA 54 and/or local codes having jurisdiction.

In Canada, please consult provincial and/or local authorities having jurisdiction for installations at elevations above 4,500 feet (1,370m).

### Remote ON/OFF Hi/Lo Wall Mounted Transmitter

The DVR28 is equipped with a wireless transmitter. No wires are required.

### Gas Line Installation



**When purging the gas lines, the front window frame assembly must be removed.**

The gas pipeline can be brought in under the bottom of the fireplace. The gas line connections will be covered by bottom trim. Refer to Figure 7 for gas line dimensions. Use 1/2" rigid pipe. When gas line is in place under the fireplace, install supplied 1/2" FPT to 3/8" flare brass fitting. Connect preinstalled flex line on fireplace to brass fitting with 3/8" flare fitting on supply line.

The gas line connection can be made with 3/8" rigid pipe or an approved flex connector. Since some municipalities have additional local codes, it is always best to consult your local authority and the National Fuel Gas Code, ANSI Z223.1/NFPA 54 in the USA or the CSA-B149.1 installation code.

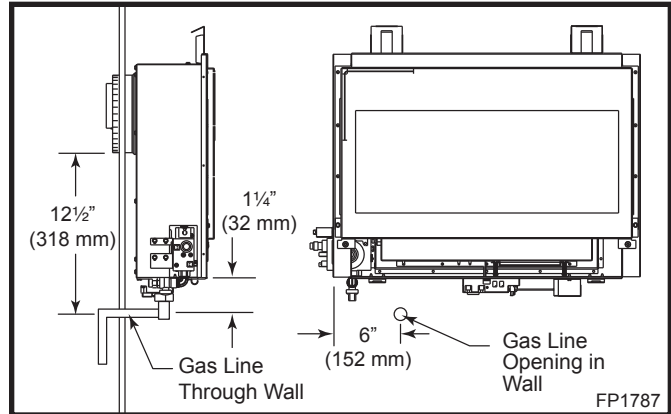

Fig. 7 Recommended gas line installation.



**Always check for gas leaks with a mild soap and water solution applied with a brush no larger than 1" (25 mm). Never apply soap and water solution with a spray bottle. Do not use an open flame for leak testing.**



**The fireplace valve must not be subjected to any test pressures exceeding 1/2 psi. Isolate or disconnect this or any other gas appliance control from the gas line when pressure testing.**

The gas control is equipped with a captured screw type pressure test point, therefore it is not necessary to provide a 1/8" test point up stream of the control.

When using a flex connector use only approved fittings. Always provide a union when using black iron pipe so the gas line can be easily disconnected for burner servicing. See gas specification for pressure details and ratings.

The fireplace valve must not be subjected to any test pressures exceeding 1/2 psi. Isolate or disconnect this and any other gas appliance control from the gas line when pressure testing.

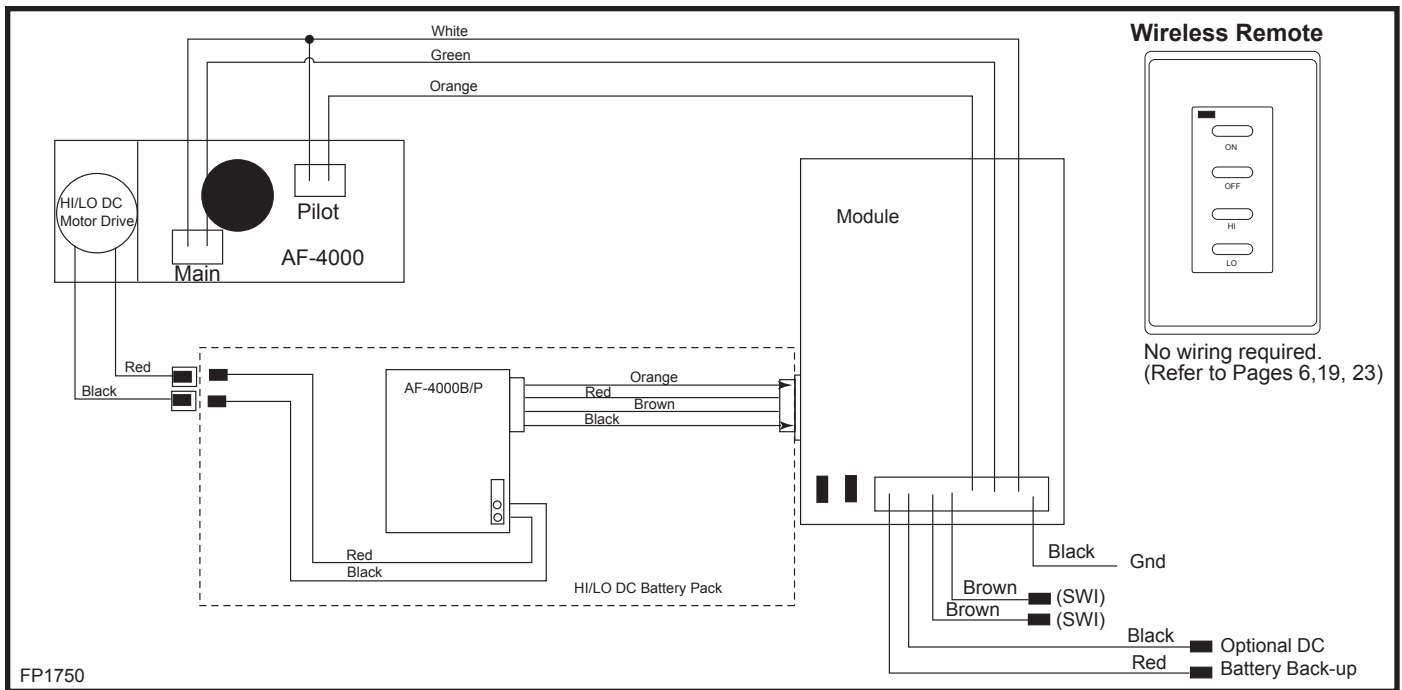

Fig. 8 DVR28 wiring diagram.

### Restrictor Plate Installation

The DVR28IN is shipped with a restrictor plate for extended pipe runs other than straight out installations. A guide for usage is shown in Figure 10.

**NOTE:** Some installations may require some adjustment by the installer for optimum flame appearance. Optimum flame appearance would be a flame not subject to tall dirty yellow flames or lifting of flames from burner tube.

### Installation

1. Remove front glass assembly. Refer to Window Frame Removal section on Page 18.
2. Remove three (3) screws securing flue diverter to top of combustion case. Remove flue diverter. (Fig. 9)

**CAUTION:** Use care not to damage rear refractory.

3. Remove two (2) screws on sides of flue opening.
4. Install restrictor plate with two (2) screws removed from back of unit. (Fig. 9)
5. Re-install flue diverter with three (3) screws removed earlier.
6. Reinstall glass assembly. (Refer to Page 18)

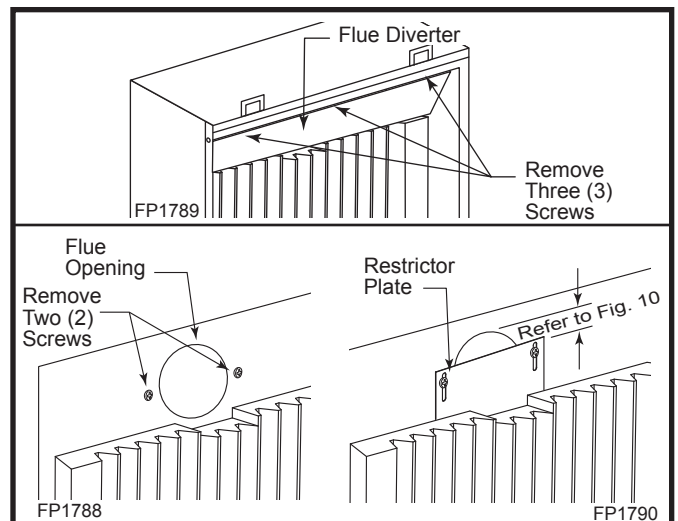

Fig. 9 Install restrictor plate for optimum flame appearance.

### Examples for Extended Run/Restrictor Plate Settings

1. 90° Elbow, vertical 8' (2.4 m), 90° elbow, out 20' (6 m)
2. 90° Elbow, vertical 11' (3.4 m), 90° elbow, out 13' (4 m)
3. 90° Elbow, vertical 20' (6 m), 90° elbow, out 7' (2 m)
4. 90°, 40' (12 m) vertical

Flue restricted to:

1. 1 1/8" (29 mm) opening in flue pipe outlet
2. 7/8" (22 mm) opening in flue pipe outlet
3. 3/4" (79 mm) opening in flue pipe outlet
4. 1 3/8" (35 mm) opening in flue pipe outlet

Figure 10

## General Venting

Your fireplace is approved to be vented either through the side wall, or vertically through the roof.

- Only CFM Corporation venting components specifically approved and labelled for this fireplace may be used.
- If vent termination is installed in an accessible location, Vent Termination Guard #53525 shall be installed.
- Vent terminations shall not be recessed into a wall or siding.
- Horizontal venting which incorporates the twist lock pipe must be installed on a level plane without an inclining or declining slope.

**There must not be any obstruction** such as bushes, garden sheds, fences, decks or utility buildings within 24" (610 mm) from the front of the termination hood.

Do not locate termination hood where excessive snow or ice build up may occur. Be sure to check vent termination area after snow falls, and clear to prevent accidental blockage of venting system. When using snow blowers, make sure snow is not directed towards vent termination area.

### Location of Vent Termination

It is imperative the vent termination be located observing the minimum clearances as shown on the next page.

\*Check with local codes or in absence of same with CSA B149.1 Installation Codes (1991) for Canada or follow the current National Fuel Gas Code, ANSI Z223.1/NFPA 54 for installations in the USA.



### General Venting Information - Termination Location

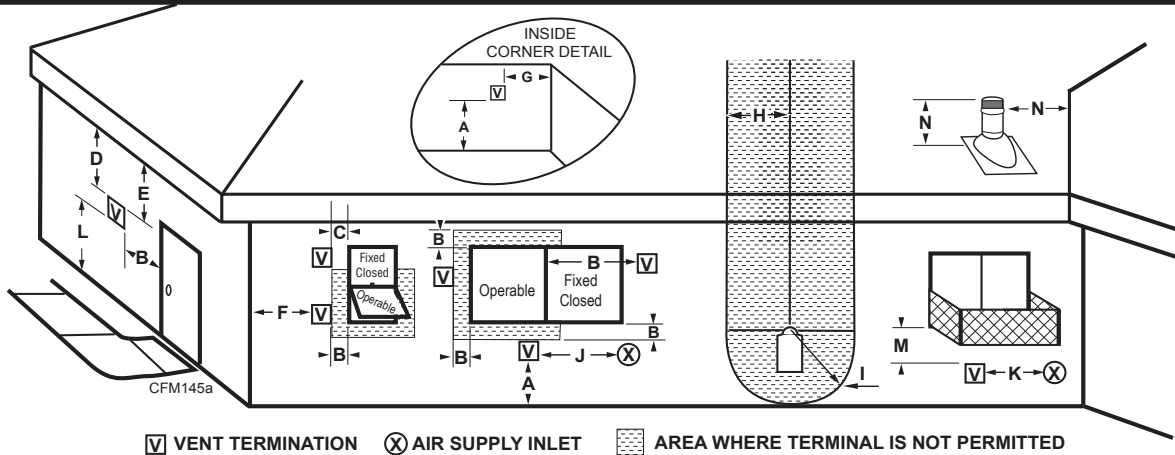

	Canadian Installations <sup>1</sup>	US Installations <sup>2</sup>
A = Clearance above grade, veranda, porch, deck, or balcony	12" (30 cm)	12" (30 cm)
B = Clearance to window or door that may be opened	6" (15 cm) for appliances < 10,000 Btuh (3kW), 12" (30 cm) for appliances > 10,000 Btuh (3kW) and < 100,000 Btuh (30kW), 36" (91 cm) for appliances > 100,000 Btuh (30kW)	6" (15 cm) for appliances < 10,000 Btuh (3kW), 9" (23 cm) for appliances > 10,000 Btuh (3kW) and < 50,000 Btuh (15kW), 12" (30 cm) for appliances > 50,000 Btuh (15kW)
C = Clearance to permanently closed window	12" (305 mm) recommended to prevent window condensation	12" (305 mm) recommended to prevent window condensation
D = Vertical clearance to ventilated soffit located above the terminal within a horizontal distance of 2' (610mm) from the center line of the terminal	18" (458 mm)	18" (458 mm)
E = Clearance to unventilated soffit	12" (305 mm)	12" (305 mm)
F = Clearance to outside corner	see next page	see next page
G = Clearance to inside corner (see next page)	see next page	see next page
H = Clearance to each inside of center line extended above meter/regulator assembly	3' (91 cm) within a height of 15' (5 m) above the meter/regulator assembly	3' (91 cm) within a height of 15' (5 m) above the meter/regulator assy
I = Clearance to service regulator vent outlet	3' (91 cm)	3' (91 cm)
J = Clearance to nonmechanical air supply inlet to building or the combustion air inlet to any other appliances	6" (15 cm) for appliances < 10,000 Btuh (3kW), 12" (30 cm) for appliances > 10,000 Btuh (3kW) and < 100,000 Btuh (30kW), 36" (91cm) for appliances > 100,000 Btuh (30kW)	6" (15 cm) for appliances < 10,000 Btuh (3kW), 9" (23 cm) for appliances > 10,000 Btuh (3kW) and < 50,000 Btuh (15kW), 12" (30 cm) for appliances > 50,000 Btuh (15kW)
K = Clearance to a mechanical air supply inlet	6' (1.83 m)	3' (91 cm) above if within 10 feet (3 m) horizontally
L = Clearance above paved sidewalk or paved driveway located on public property	7' (2.13 m)†	7' (2.13 m)†
M = Clearance under veranda, porch, deck or balcony	12" (30 cm)‡	12" (30 cm)‡
N = Clearance above a roof shall extend a minimum of 24" (610 mm) above the highest point when it passes through the roof surface, and any other obstruction within a horizontal distance of 18" (450 mm).		

1 In accordance with the current CSA-B149 Installation Codes  
 2 In accordance with the current ANSI Z223.1/NFPA 54 National Fuel Gas Codes  
 † A vent shall not terminate directly above a sidewalk or paved driveway which is located between two single family dwellings and serves both dwellings  
 ‡ only permitted if veranda, porch, deck or balcony is fully open on a minimum 2 sides beneath the floor:  
 NOTE: 1. Local codes or regulations may require different clearances.  
 2. The special venting system used on Direct Vent Fireplaces are certified as part of the appliance, with clearances tested and approved by the listing agency.  
 3. CFM Corporation assumes no responsibility for the improper performance of the appliance when the venting system does not meet these requirements.

Fig. 11 Vent termination locations.  
20012301

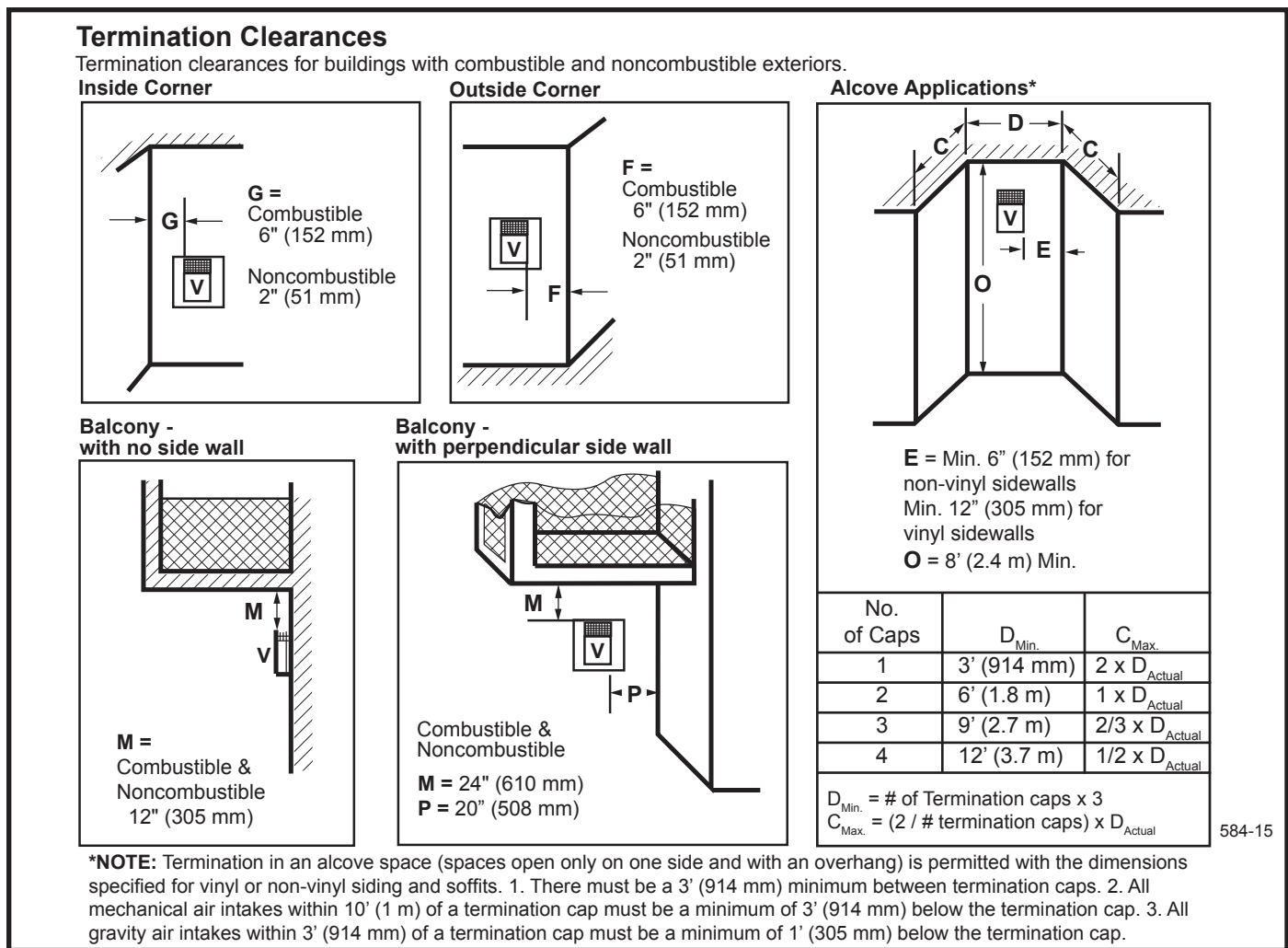

Fig. 12 Termination clearances.

## General Information Assembling Vent Pipes

### Canadian Installations:

Venting system must be installed in accordance with the current CSA-B149.1 installation code.

### USA Installations:

The venting system must conform with local codes and/or the current National Fuel Gas code ANSI Z223.1/ NFPA 54.

Only venting components manufactured by CFM Corporation can be used in Direct Vent systems.

### Twist Lock Pipes

When using CFM Corporation twist-lock pipe it is not necessary to use sealant on the joints. The only areas of the venting system that need to be sealed with high temperature silicone sealant are the sliding joints of any telescopic vent section used in the system.

To join the twist lock pipes together, simply align the beads of the male end with the grooves of the female end, then while bringing the pipe together, twist the pipe

until the flange on the female end contacts the external flange on the male end. It is recommended that you secure the joints with three (3) sheet metal screws, however this is not mandatory with twist lock pipe.

To make it easier to assemble the joints we suggest putting a lubricant (Vaseline or similar) on the male end of the twist lock pipe prior to assembly.

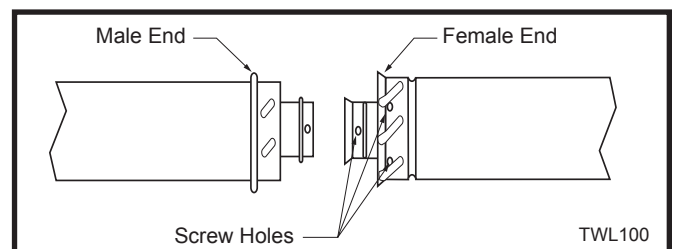

Fig. 13 Twist-lock pipe joints.

## How to Use the Vent Graph

The vent chart should be read in conjunction with the following vent installation instructions to determine the relationship of the vertical and horizontal dimensions of the vent system.

1. Determine the height of the center of the horizontal vent pipe exiting through the outer wall. Using this dimension on the Sidewall Vent Graph (Fig. 14) locate the point intersecting with slanted graph line.
2. From the point of this intersection, draw a vertical line to the bottom of the graph.
3. Select the indicated dimension, and position the fireplace in accordance with same.

### Example A:

If the vertical dimension from the floor of the fireplace is 11' (3.4 m) the horizontal run to the face of the outer wall must not exceed 14' (4.3 m).

### Example B:

If the vertical dimension from the floor of the unit is 7' (2.14 m), the horizontal run to the face of the outer wall must not exceed 8½' (2.6 m).

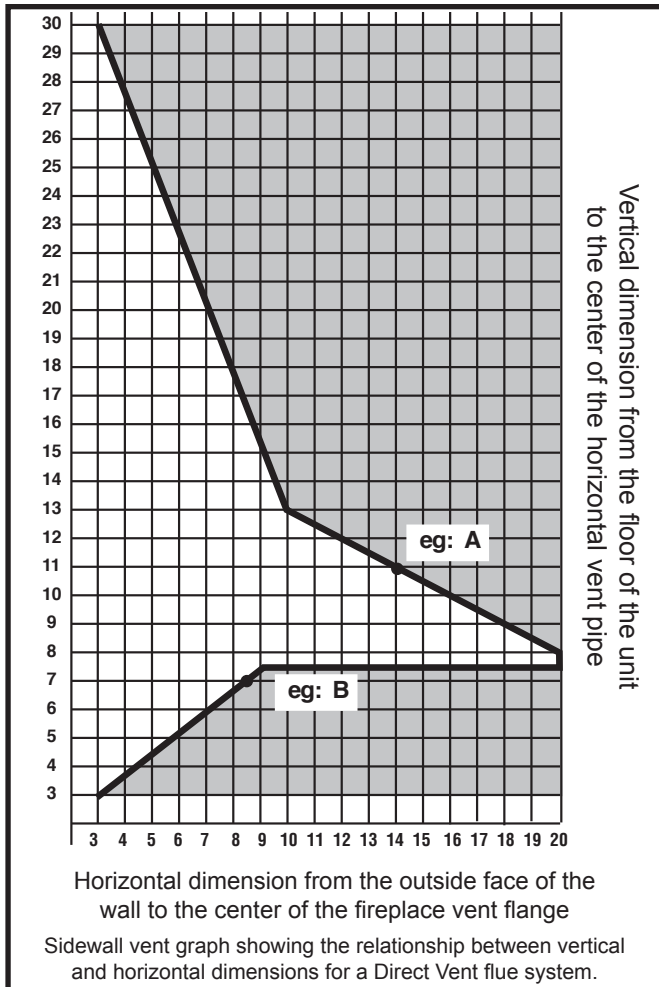

Fig. 14 Sidewall venting graph. (Dimensions in feet)

## Rear Wall Venting Applications

When installed as a rear vent unit this appliance may be vented directly to a termination located on the rear wall behind the appliance.

- Only CFM Corporation venting components are approved to be used in these applications. (Refer to "Venting Components" listed for different installation requirements)
- The maximum horizontal distance between the rear of the appliance (or end of the transition elbow in a corner application) and the outside face of the rear wall is 20" (508 mm). (Fig. 15 & 16)
- Only one 45° elbow is allowed in these installations.
- **If using a 45° elbow at fireplace, you must start out using an 8" (203 mm) or 12" (305 mm) section of pipe first attached to heater then a 45° elbow.**
- Minimum clearances between vent pipe and combustible materials are as follows:
  - Top - 2" (51 mm)
  - Sides - 1" (25 mm)
  - Bottom - 1" (25 mm)

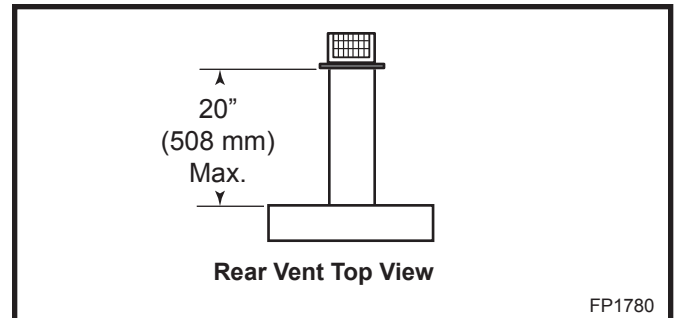

Fig. 15 Rear vent application, no elbows.

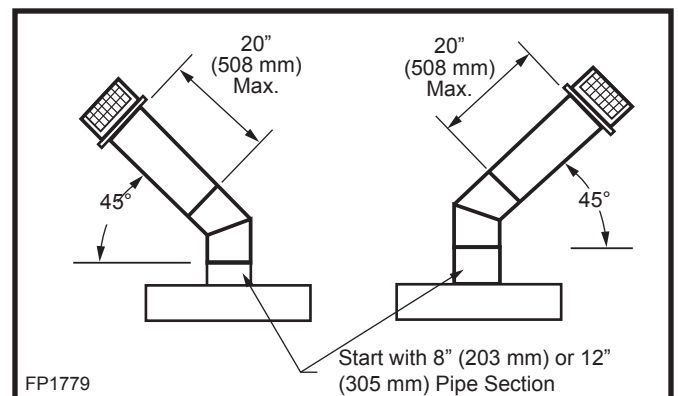

Fig. 16 Rear vent application, one 45° elbow.

## Rear Wall Installation Twist Lock Pipe

### STEP 1

Locate vent opening on the wall. To locate hole center consult with appropriate fireplace dimensions, Page 4. Frame as shown below.

**Combustible Walls** (Fig. 17): Cut a 10 $\frac{1}{8}$ " H x 9 $\frac{5}{8}$ " W (264 x 240 mm) hole through the exterior wall and frame as shown.

**Noncombustible Walls** (Fig. 17): Hole opening must be 7 $\frac{1}{2}$ " (190 mm) in diameter.



**Zero clearance sleeve is only required for combustible walls.**

### STEP 2

Measure wall thickness and cut zero clearance sleeve parts to proper length (MAXIMUM 12"/305 mm). Assemble sleeve and attach to firestop with #8 sheet metal screws (supplied). (Fig. 18)

### STEP 3

Measure the horizontal length requirement for the venting including a 2" (51 mm) overlap, i.e. from the elbow to the outside wall face plus 2" (51 mm). (Fig. 15 or 16)

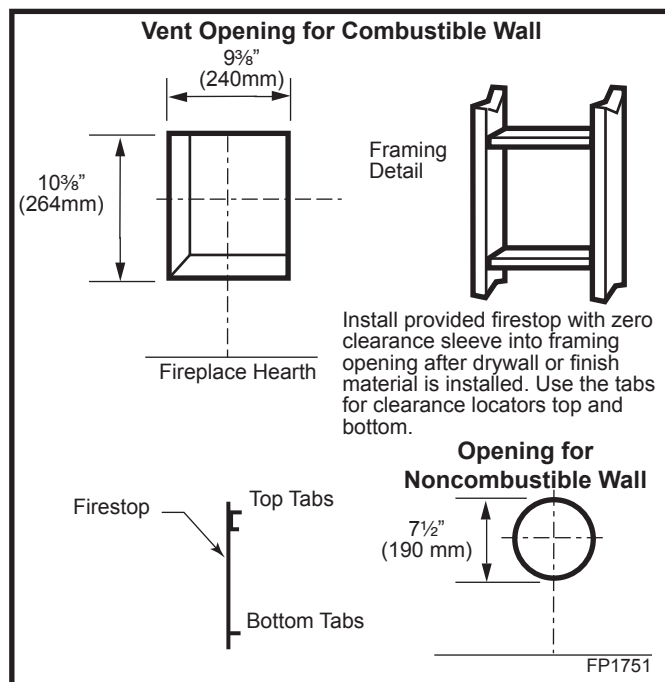

Fig. 17 Locate vent opening on wall.

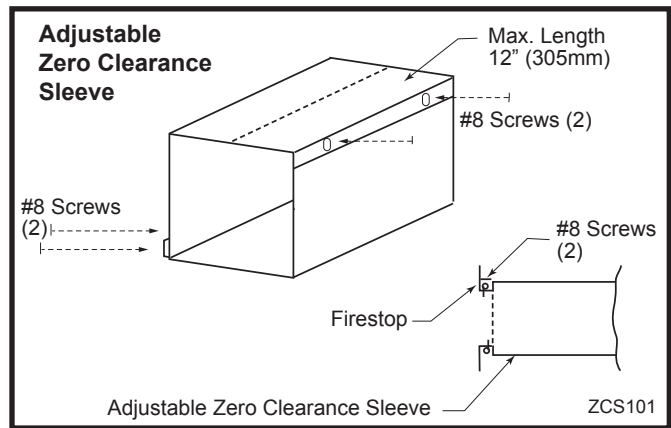

Fig. 18 Adjustable zero clearance sleeve.

### STEP 4

Install the 4" (102 mm) vent to the appliance collar and secure with three (3) sheet metal screws. Install the 7" (178 mm) vent pipe to the appliance collar and secure with three (3) sheet metal screws. It is not necessary to seal this connection. If a 45° elbow is being used, attach the elbow to the appliance in the same manner then attach the venting to the elbow.



**It is critical there is no downward slope away from the appliance when connecting the vent or elbow.**

### STEP 5

Guide the venting through the vent hole as you place the appliance in its installed position. Guide the 4" (102 mm) and 7" (178 mm) collar of the vent termination into the outer ends of the venting. Do not force the termination. If the vent pipes do not align with the termination, remove and realign the venting at the appliance flue collars. (Fig. 19) Attach the termination to the wall as outlined in the instruction sheet supplied with the termination.

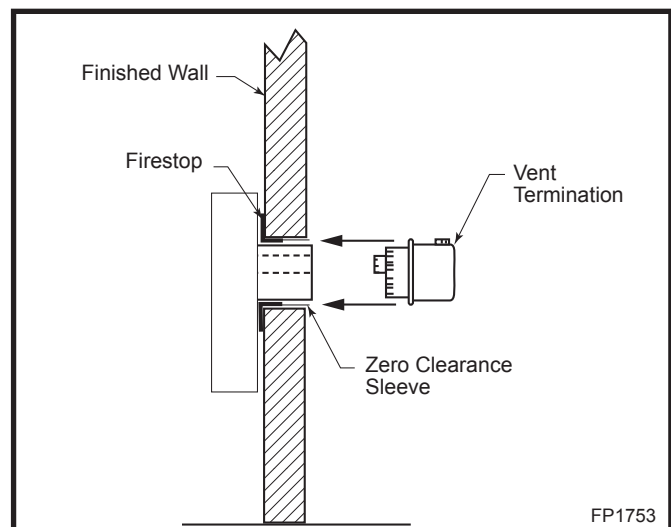

Fig. 19 Side view of final unit location.

## Vertical Sidewall Applications

Since it is very important for the venting system to maintain balance between the combustion air intake and the flue gas exhaust, certain limitations as to vent configurations apply and must be strictly adhered to.

The Vent Graph shows the relationship between vertical and horizontal side wall venting and will help to determine the various dimensions allowable.

**Minimum clearance between vent pipes and combustible materials is 2" (51 mm) on top and 1" (25 mm) on the bottom and sides unless otherwise noted.**

When vent termination exits through foundations less than 20" below siding outcrop, the vent pipe must flush up with the siding. It is always best to locate the fireplace in such a way that minimizes the number of offsets and horizontal vent length.

The horizontal vent run refers to the total length of vent pipe from the flue collar of the fireplace to the face of the outer wall.

Horizontal plane means no vertical rise exists on this portion of the vent assembly.



**When installing the appliance as a rear vent unit, the 90° or 45° transition elbow is NOT INCLUDED in the following criteria and calculations, and unless specifically mentioned should be ignored when calculating venting layouts.**

- The maximum number of 90° elbows per side wall installation is three (3). (Fig. 20)

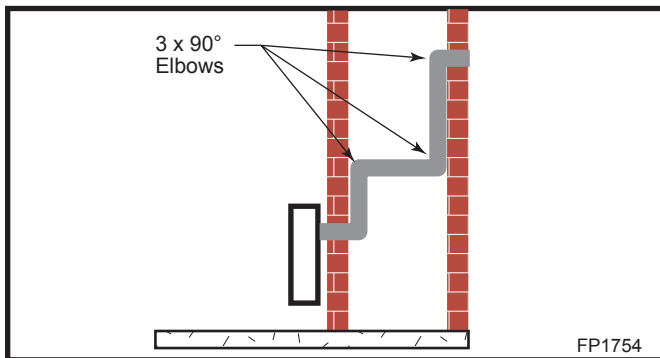

Fig. 20 Maximum three (3) 90° elbows per installation.

- If a 90° elbow is used in the horizontal vent run (level height maintained) the maximum horizontal vent length is reduced by 36" (914 mm). This does not apply if the 90° elbows are used to increase or redirect a vertical rise. (Fig. 21)

**Example:** According to the vent graph (Page 11) the maximum horizontal vent length in a system with a 7.5' (2.3 m) vertical rise is 20' (6 m) and if a 90° elbow is required in the horizontal vent it must be reduced to 17' (5.2 m). In Figure 21 Dimension A plus B must not be greater than 17' (5.2 m).

In Figure 21, dimension A plus B must not be greater than 17' (5.2 m).

- The maximum number of 45° elbows permitted per side wall installation is two (2). These elbows can be installed in either the vertical or horizontal run.
- For each 45° elbow installed in the horizontal run, the length of the horizontal run MUST be reduced by 18" (45 cm). This does not apply if the 45° elbows are installed on the vertical part of the vent system.
- The maximum number of elbow degrees in a system is 270°. (Fig. 22)

Example:

Elbow 1 = 90°

Elbow 2 = 45°

Elbow 3 = 45°

Elbow 4 = 90°

**Total angular variation = 270°**

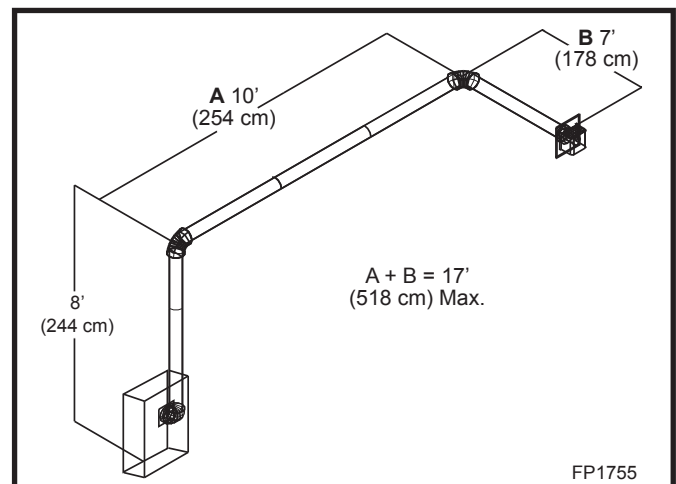

Fig. 21 Maximum vent run with elbows.

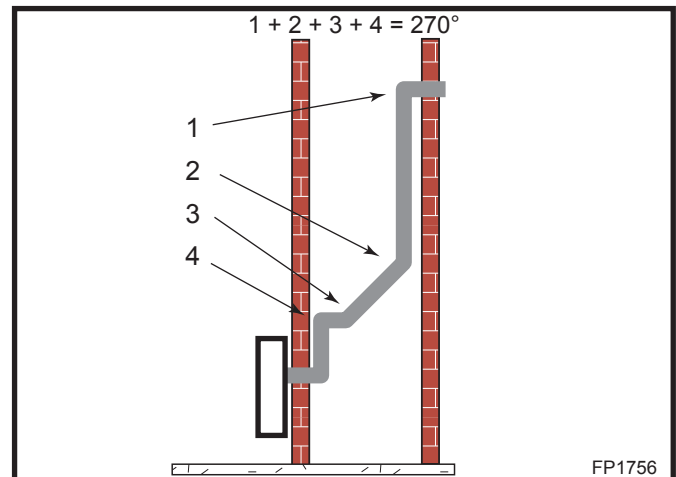

Fig. 22 Maximum elbow usage.

## Below Grade Installations

When it is not possible to meet the required vent terminal clearances of 12" (305 mm) above grade level a snorkel kit is recommended. This allows installation depth of down to 7" (178 mm) below grade level. The 7" is measured from the center of the horizontal vent pipe as it penetrates through the wall.

Ensure the sidewall venting clearances are observed. If venting system is installed below ground, we recommend a window well with adequate and proper drainage to be installed around the termination.

If installing a snorkel, a minimum 24" (610 mm) vertical rise is necessary. The maximum horizontal run with the 24" vertical pipe is 36" (914 mm). This measurement is taken from the collar of the fireplace (or transition elbow) to the face of the exterior wall. See the Sidewall Venting Graph for extended horizontal run if the vertical exceeds 24" (610 mm).

1. Establish vent hole through the wall. (Fig. 17)
2. Remove soil to a depth of approximately 16" (406 mm) below base of snorkel. Install window well (not supplied). Refill hole with 12" (305 mm) of coarse gravel leaving a clearance of approximately 4" (102 mm) below snorkel. (Fig. 23)
3. Install vent system. Refer to Page 12.
4. Ensure a watertight seal is made around the vent pipe coming through the wall.
5. Apply high temperature sealant caulking (supplied) around the 4" and 7" snorkel collars.
6. Slide the snorkel into the vent pipe and secure to the wall.
7. Level the soil to maintain a 4" (102 mm) clearance below snorkel. (Fig. 23)

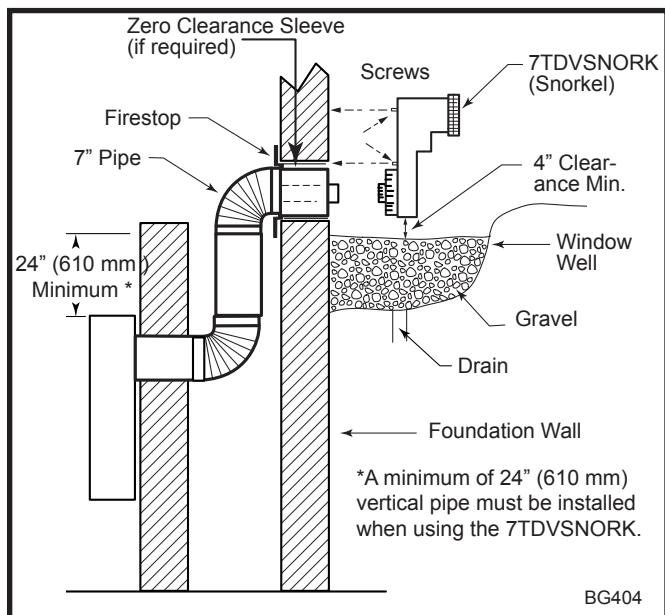

Fig. 23 Below grade installation.



**Do not backfill around snorkel.**

**A clearance of at least 4" must be maintained between the snorkel and the soil.**

If the foundation is recessed, use recess brackets (not supplied) for securing lower portion of the snorkel. Fasten brackets to wall first, then secure to snorkel with self drilling #8 x 1/2 sheet metal screws. It will be necessary to extend vent pipes out as far as the protruding wall face. (Fig. 24)

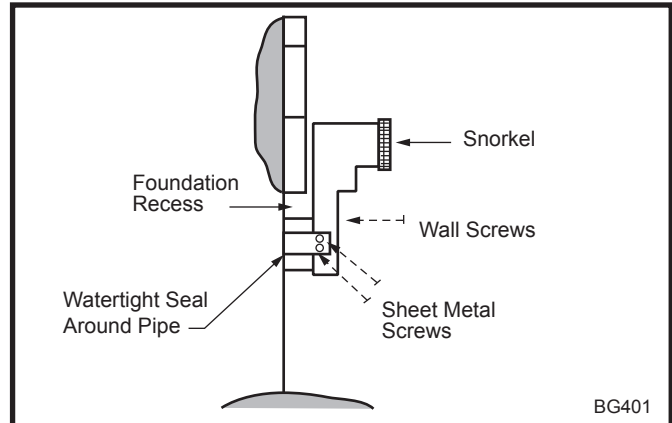

Fig. 24 Snorkel installation, recessed foundation.

## Vertical Through-the-Roof Application

This gas fireplace has been approved for:

- Vertical installations up to 40' (12 m) in height. Up to a 10' (3 m) horizontal vent run can be installed within the vent system using a maximum of two 90° elbows. (Fig. 25)

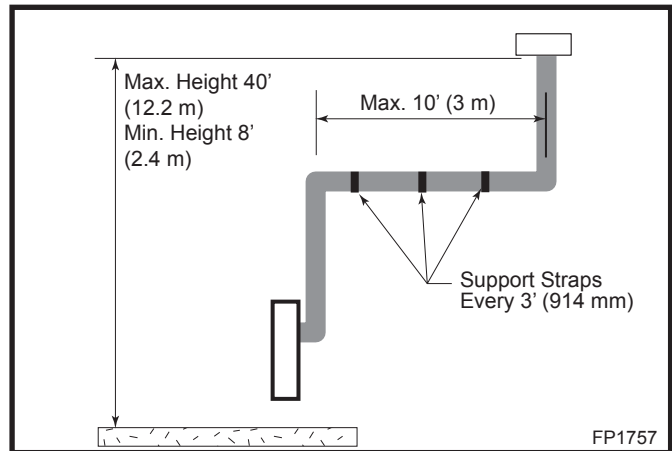

Fig. 25 Support straps for horizontal runs.

- Up to two 45° elbows may be used within the horizontal run. For each 45° elbow used on the horizontal plane, the maximum horizontal length must be reduced by 18" (450 mm).

**Example:** Maximum horizontal length:

No elbows	=	10' (3 m)
1 x 45° elbow	=	8.5' (2.6 m)
2 x 45° elbows	=	7' (2.1 m)

- A minimum of an 8' (2.5m) vertical rise is required.
- Two sets of 45° elbow offsets may be used within the vertical sections. From 0 to a maximum of 8' (2.5 m) of vent pipe can be used between elbows. (Fig. 26)
- 7DVCS supports offsets. (Fig. 28) This application will require that you first determine the roof pitch and use the appropriate starter kit. (Refer to Venting Components List)
- The maximum angular variation allowed in the system is 270°. (Fig. 26)
- The minimum height of the vent above the highest point of penetration through the roof is 2' (610 mm). (Fig. 29)

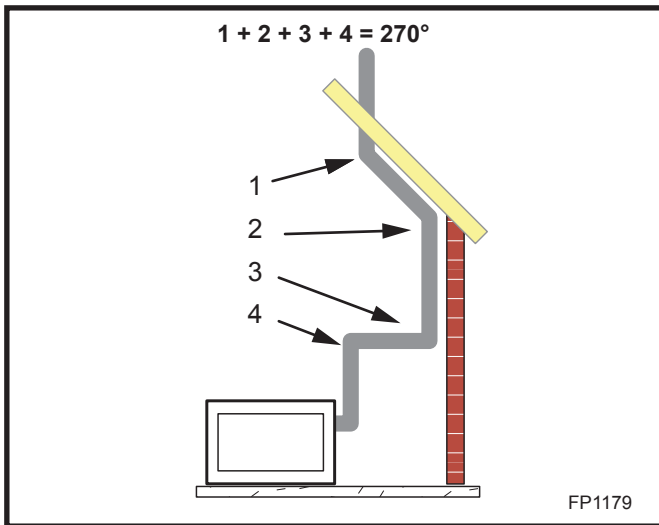

Fig. 26 Maximum elbow usage.

### Vertical Through-the-Roof Installation

1. Locate your fireplace.
2. Plumb to center of the (4") flue collar from ceiling above and mark position.
3. Cut opening equal to 9<sup>3</sup>/<sub>8</sub>" x 9<sup>3</sup>/<sub>8</sub>" (240 x 240 mm).
4. Proceed to plumb for additional openings through the roof. In all cases, the opening must provide a minimum of 1 inch clearance to the vent pipe, i.e., the hole must be at least 9<sup>3</sup>/<sub>8</sub>" x 9<sup>3</sup>/<sub>8</sub>" (240 x 240 mm).
5. Place fireplace into position.
6. Place firestop(s) #7DVFS or Attic Insulation Shield #7DVAIS into position and secure. (Fig. 27)
7. Install roof support (Fig. 44) and roof flashing making sure upper flange is below the shingles. (Fig. 28)
8. Install appropriate pipe sections until the venting is above the flashing. (Fig. 30)
9. Install storm collar and seal around the pipe.
10. Add additional vent lengths for proper height. (Fig. 29)
11. Apply high temperature sealant to 4" and 7" collars of vertical vent termination and install.

If there is a room above ceiling level, fire stop spacer must be installed on both the bottom and the top side of the ceiling joists. If an attic is above ceiling level a 7DVAIS (Attic Insulation Shield) must be installed.

The enlarged ends of the vent section always face downward.

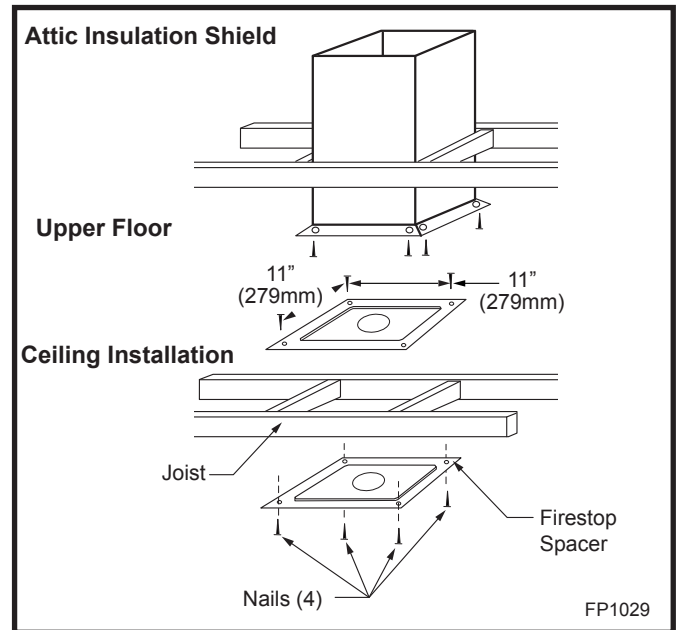

Fig. 27 Place firestop spacer(s) and secure.

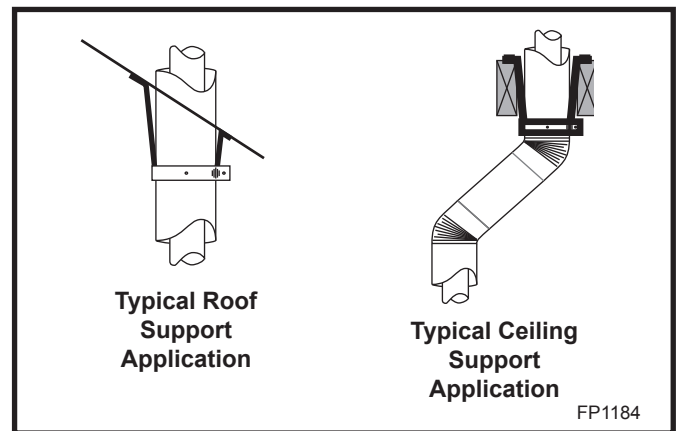

Fig. 28 Venting supports.

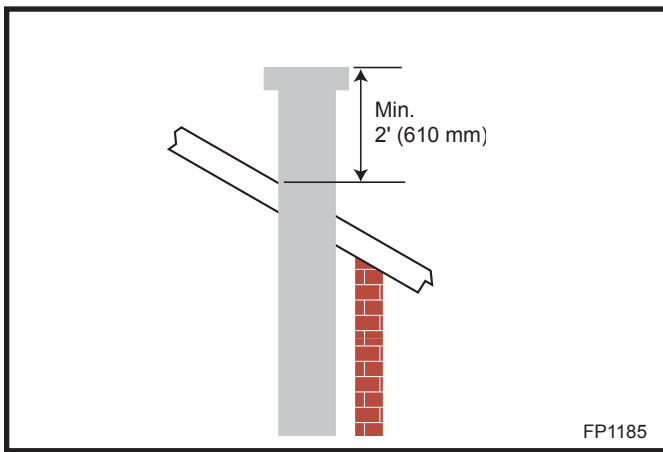

Fig. 29 Minimum termination to roof clearance.

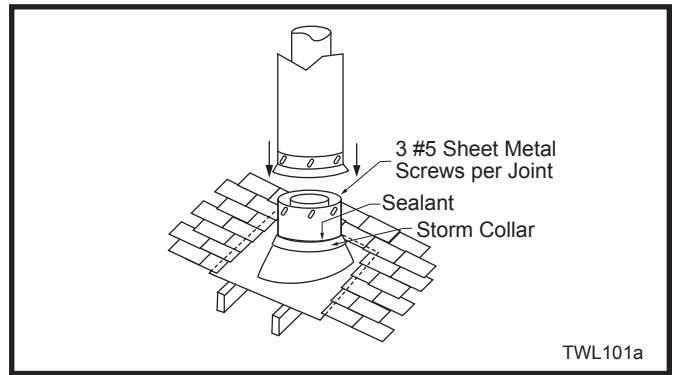
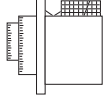
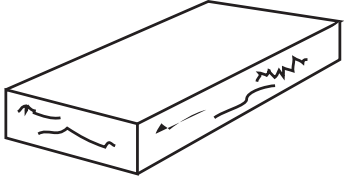
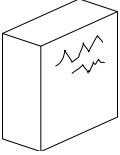
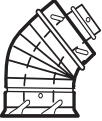

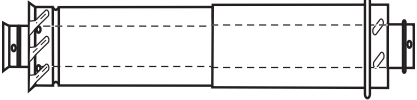
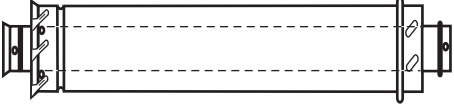
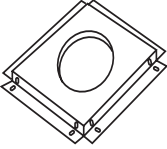



Fig. 30 Roof flashing.



## Venting Components

	<p>7TDVRVT - Through the wall Rear Vent Termination</p>
	<p>Starter Kit -            Model 7TDVSK - Sidewall Venting (Twist Lock Pipe)            Model 7FDVSK - Sidewall Venting (Flex Vent Pipe)            Models 7TDVTK/TV - Hot Touch Termination Kits            Model 7TDVTVTK/TV - Cool Touch Termination Kit            Starter Kit - Model 7TDVSKV - Vertical Venting            for 7TDVSKV-A order 1/12 to 6/12 roof pitch            for 7TDVSKV-B order 7/12 to 12/12 roof pitch            for 7TDVSKV-F order flat roof            Starter Kit for Below Grade Installation            Model 7TDVSKS -Snorkel Kit (Twist Lock Pipe)            Model 7FDVSKS -Snorkel Kit (Flex Vent Pipe)</p>
	<p>Starter Pipe            Model 7TDVP 20/8 - 24" Starter Pipe Bulk            Model 7FDVP 30/8 - 30" Flex Pipe Bulk</p>
	<p>45° Elbow            7TDV45 for Rear Vent to Vertical Vent            or Vertical/Horizontal Offsets</p>
	<p>90° Transition Elbow            7TDVRT90 for Rear Vent to Vertical Vent            90° Elbow            7TDV90 Vertical/Horizontal Offset</p>
	<p>Telescopic vent sections            7TDVP1117 -11" to 17" adjustable length            7TDVP3567 -35" to 67" adjustable length</p>
	<p>Pipe sections for vertical or horizontal venting            Model 7TDVP8" - 4 per box            Model 7TDVP12" - 4 per box            Model 7TDVP24" - 4 per box            Model 7TDVP36"            Model 7TDVP48"</p>
	<p>Firestop Spacer            20012362</p>
	<p>Attic Insulation Shield            Model 7DVAIS</p>
	<p>Vertical/Horizontal Combination Offset Support            Model 7DVCS</p>

# Operating Instructions

## Glass Information



**Only glass approved by CFM Corporation should be used on this fireplace.**

- The use of any non-approved replacement glass will void all product warranties.
- Care must be taken to avoid breakage of the glass.
- **Do not operate appliance with glass front removed, cracked or broken.**
- **Replacement glass (complete with gasket and window frame) is available through your CFM Corporation dealer and should only be installed by a licensed qualified service person.**

## Window Frame Assembly Removal

1. Turn the fireplace OFF (including the pilot).
2. If the unit has been operating, allow time for the components to cool.
3. Remove two (2) bolts on bottom side of unit holding front trim face on. (Fig. 32)
4. Remove front trim face by tilting bottom out and lifting face off unit. (Fig. 32)
5. Remove two (2) bolts securing bottom door frame to unit. (Fig. 31)
6. Tilt window frame assembly out slightly at the bottom, lift the frame up and away from the fireplace. (Fig. 31)
7. To replace window frame assembly reverse procedure.

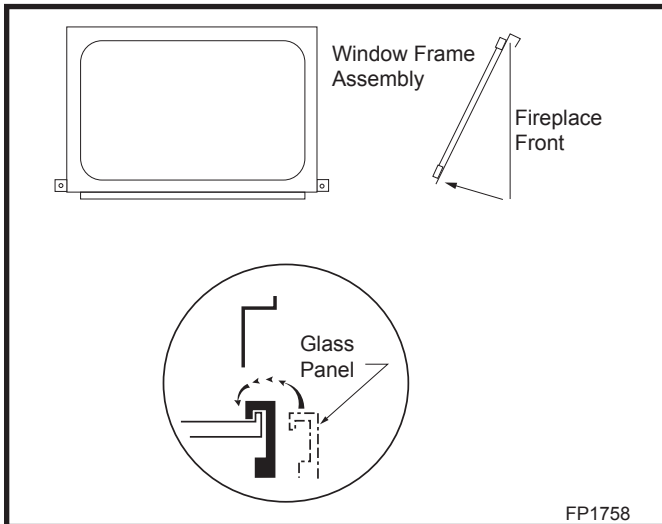

Fig. 31 Window frame assembly removal.

## Glass Cleaning

It is necessary to clean the glass periodically. During start-up condensation, which is normal, forms on the inside of the glass and causes lint, dust and other airborne particles to cling to the glass surface. Also initial paint curing may deposit a slight film on the glass. It is therefore recommended the glass be cleaned two or three times with a non-ammonia household cleaner and warm water (gas fireplace glass cleaner is recommended). After the initial cleaning process the glass should be cleaned two or three times during each operating season depending on the environment in the house.



**Clean the glass after the first two weeks of operation.**

**Do not clean glass when hot.**

**Do not use abrasive cleaners.**

**Do not strike or slam the glass.**

## Removal and Re-fitting the Curve Face

The Curve face is fitted to the fireplace by hooking the top edge of the face over the mounting brackets as shown in Figure 32. Secure with two (2) screws on the bottom face of the trim. (Fig. 32)

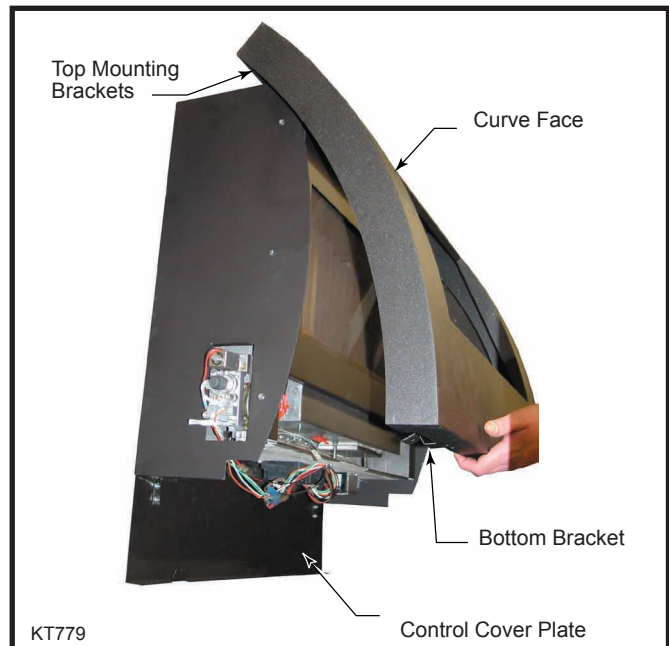

Fig. 32 Hang Curve Face in place.

### Flame & Temperature Adjustment

To adjust Hi/Lo setting, push either the high or low control button on remote control transmitter.

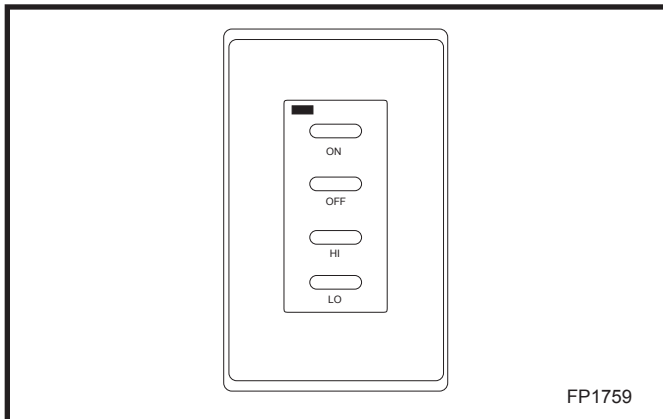

Fig. 33 Flame adjustment for American Flame valve.

### Flame Characteristics

It is important to periodically perform a visual check of the pilot and the burner flames. Compare them to Figures 34-35. If any of the flames appear abnormal call a service person.

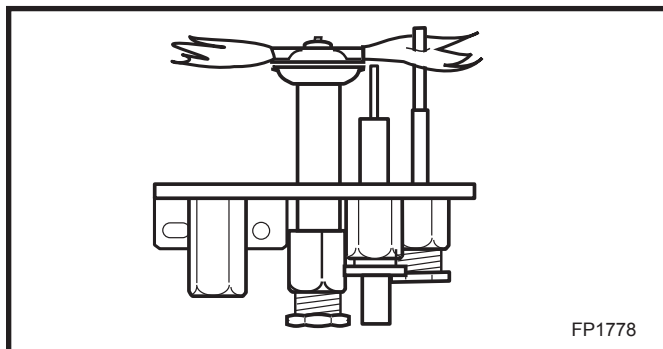

Fig. 34 Correct pilot flame appearance.



Fig. 35 Correct DVR28 flame. Center flame should be approximately 5½" (140 mm) high.

### Inspecting the Venting System

This appliance venting system is designed and constructed to develop a positive flow adequate to remove flue gases to the outside atmosphere.

Any foreign objects in the venting system, except those designed specifically for the venting system, may cause spillage of flue gases.

To inspect the venting system, make sure the main gas valve is off. Remove window frame assembly (Refer to Window Frame Assembly Removal Section). Using a flashlight, check the area above the baffle in the combustion dome. Clean if necessary.

## Lighting & Operating Instructions

### For Fireplaces equipped with AF4000 Gas Valve

**Warning:** If you do not follow these instructions exactly, a fire or explosion may result, causing property damage, personal injury and loss of life.

### For Your Safety, Read the Following Warnings before Lighting the Appliance

- A. This fireplace is equipped with an ignition device which automatically lights the pilot. **DO NOT** try to light the pilot by hand.
- B. **BEFORE OPERATING**, smell all around the appliance area for gas. Be sure to smell next to the floor because some gas is heavier than the air and will settle on the floor.  
**What to do if you smell gas**
  - **Do not try to light any appliance.**
  - **Do not operate any electrical switch.**
  - **Do not use any phone in your building.**
- **Immediately call your gas supplier from a neighbor's phone. Follow the gas suppliers instructions.**
- **If you cannot contact your gas supplier call the Fire Department**
- C. Do not use this appliance if any part has been under water. Immediately call a qualified service technician to inspect the appliance and replace any part of the control system and any gas control that has been under water.

### Lighting Instructions

1. **STOP!** Read the safety information above before continuing.
2. This appliance is equipped with an ignition device which automatically lights the pilot. **DO NOT** try to light the pilot by hand.
3. Access the gas control by removing the side cover access door on the left side of the unit.
4. Turn the remote switch, if used, OFF. Turn the wireless remote, if used, OFF.
5. Wait five (5) minutes to clear out any gas. Then smell for gas, including near the floor. If you smell gas, STOP. Follow instruction B in the safety warnings above. If you do not smell gas, go on to the next step.
6. Close the access door.
7. If the appliance will not operate, follow the instructions **TURNING OFF THE GAS TO THE APPLIANCE**, and call your service technician or gas supplier.

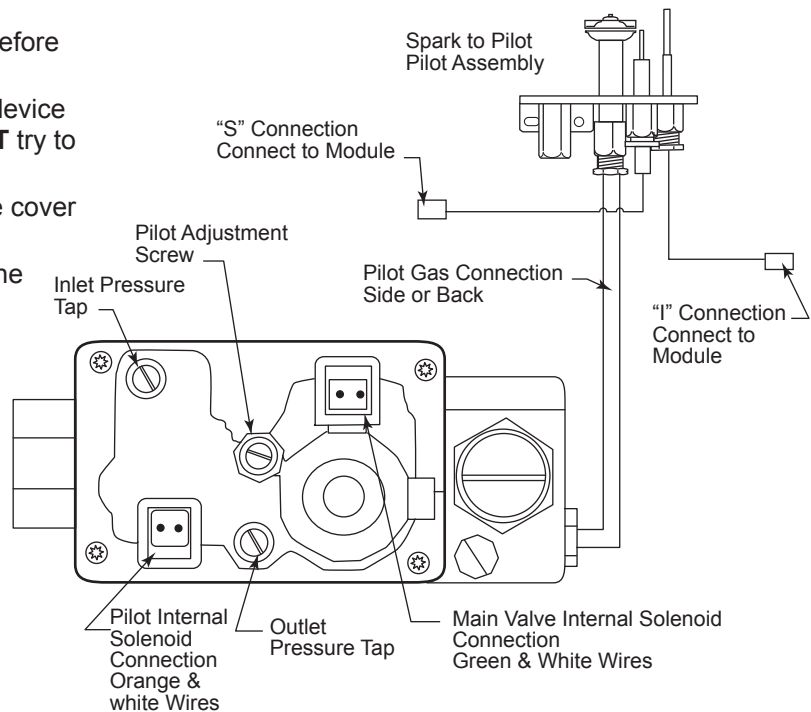

### Turning Off the Gas to the Appliance

1. Turn the remote switch to the OFF position.
2. Turn OFF all electrical power to the fireplace if service is required.
3. Open the lower access panel.
4. Turn the shut-off valve on the flexible gas line to the OFF position.

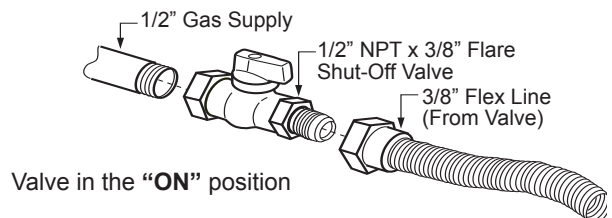

## Troubleshooting

### AF4000 Valve

If erratic system behavior is observed that cannot be resolved by the methods outlined below, ensure that there is not a transmitter with batteries installed that may be interfering. If a transmitter is packed with batteries installed, its buttons may be depressed sending a constant signal which can interfere with the transmission of desired signals. A transmitter with new batteries can have a range of over 100' (30.4 m).

Module will not learn transmitter

- Ensure the REMOTE/OFF switch on the side of the module (Fig. 36) is set to REMOTE.
- Make sure the batteries in both the transmitter and receiver are installed in the proper direction (Fig. 39, 40) and are not drained. Individual battery voltage should be no less than 1.4V for AA and AAA batteries, 2.8V for button cells, and 9.0V for 12V batteries.
- Verify the transmitter indicates a signal is being sent. With thermostat transmitters, the LCD display should indicate ON or OFF depending on which button is being pressed. The LED indicator should illuminate on wall transmitters and on/off hand-held transmitters. (Fig. 39) Buttons should be pressed and held for 1 to 2 seconds to ensure a complete signal is sent.
- Make sure the transmitter is within the 20' (6 m) operational range of the receiver.
- Ensure the 4-pin lead-set is securely connected from the battery pack to the control module's AUX connection. (Figs. 37) If the A/C power adapter is used, make sure the leads from the adapter are securely connected to the POWER terminals on the control module. (Fig. 38)
- Press and hold the LEARN button on the module (Fig. 37) for approximately 10 seconds to clear the memory (you should hear a series of beeps from the receiver). Then press and release the learn button (you should hear a single beep from the receiver), immediately press either the ON or OFF button on the transmitter (you should hear a series of beeps indicating the transmitter code has been learned).

**Figure 36: AF4000  
MOD Module Right  
Side**

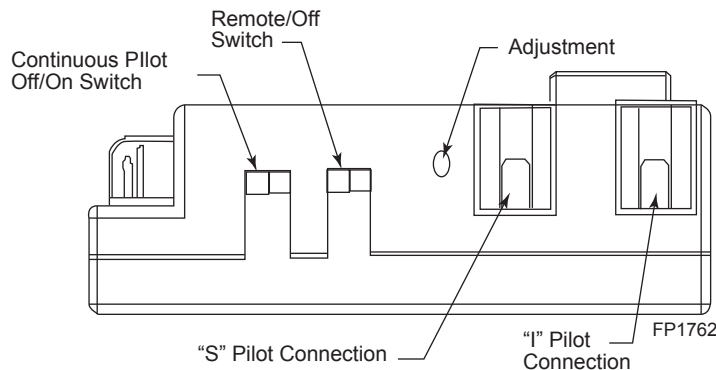

**Figure 37: AF4000  
MOD Module Left  
Side**

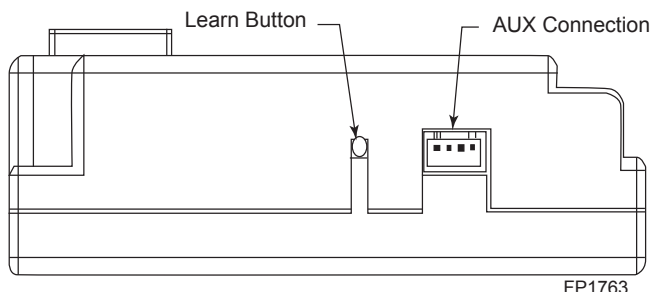

## Troubleshooting AF4000 Valve (continued)

Pilot will not light/stay lit

- Verify the gas supply is turned on.
- Verify the receiver is receiving the signal from the transmitter by listening for a beep from the receiver when ON is pressed on the transmitter. If you do not hear a beep, ensure the module has learned the transmitter (see above).
- Ensure the orange lead from the pilot assembly igniter is securely connected to the terminal labeled "I" and the white lead from the flame rectification sensor is securely connected to the terminal labeled "S" on the control module. (Fig. 36)
- Make sure the orange and white leads from the module are securely connected to the terminals labeled "PILOT" on the valve body. (Fig. 41)
- Ensure the black GROUND wire is securely connected to an appropriate metal portion of the valve or pilot assembly. **A proper ground is essential to spark igniter operation.**
- Make certain the pilot flame is in contact with the flame rectification sensor on the pilot assembly. This valve is equipped with a pilot flame adjustment screw. (Fig. 41) If the pilot flame is too small it will not contact the flame rectification sensor and will not complete the safety circuit.

**Figure 38: AF4000 MOD Module End**

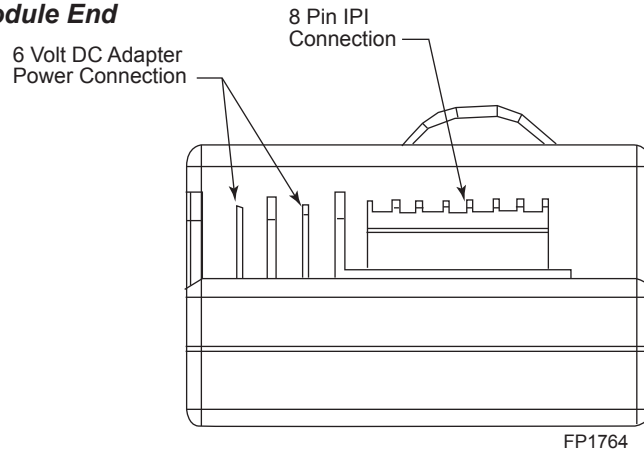

**Figure 39: Wall Transmitter Face**

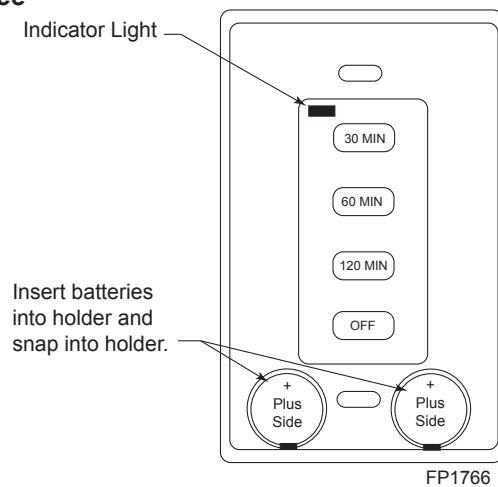

## Troubleshooting AF4000 Valve (continued)

Pilot flame is always on/ will not extinguish	<ul style="list-style-type: none"> <li>• Ensure the CONTINUOUS PILOT switch on the control module (Fig. 36) is set to OFF.</li> </ul>
Main flame will not light	<ul style="list-style-type: none"> <li>• Verify the gas supply is turned on.</li> <li>• Ensure the pilot flame will ignite. If not, see pilot flame troubleshooting above.</li> <li>• Make sure the green and white leads from the module are securely connected to the terminals labeled "MAIN: on the valve body. (Fig. 41)</li> <li>• Make certain the pilot flame is in contact with the flame rectification sensor on the pilot assembly. This valve is equipped with a pilot flame adjustment screw. (Fig. 41) If the pilot flame is too small it will not contact the flame rectification sensor and will not complete the safety circuit.</li> <li>• Ensure the pilot flame is properly located to ignite the main flame.</li> </ul>
Flame height adjustment will not work/works backwards	<ul style="list-style-type: none"> <li>• Ensure the black and red leads from the battery pack or the AF4000 110H/L module are securely connected to the red and black leads from the motor drive or H/L latching solenoid located on the valve body (red to red and black to black).</li> <li>• Verify the selector switch on the battery pack is set to DC MOTOR DRIVE or LATCHING SOLENOID, depending upon which device is installed. (Fig. 40)</li> <li>• Check functionality with all transmitters to determine if there is an issue with the main control system or an individual transmitter. If the issue is with an individual transmitter, make sure the batteries in both the transmitter and receiver are installed in the proper direction (Fig. 39, 40) and are not drained. Individual battery voltage should be no less than 1.4V for AA and AAA batteries, 2.8V for button cells, and 9.0V for 12V batteries.</li> </ul>

**Figure 40: Battery Pack - Battery Compartment**

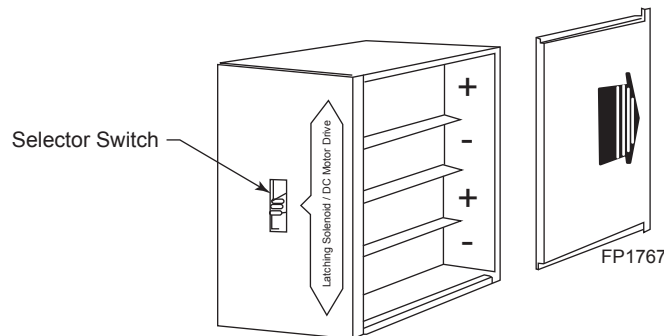

**Figure 41: AF4000 Valve Face**

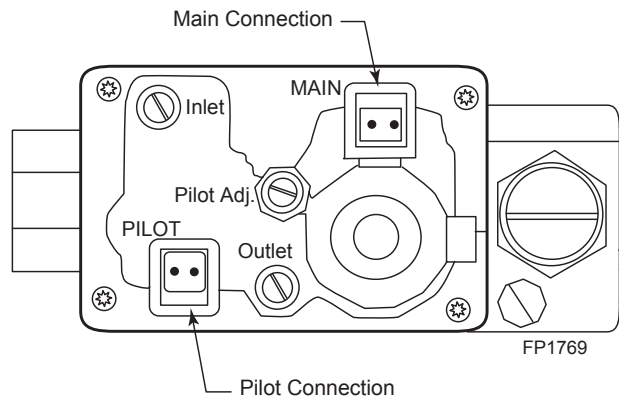

## Maintenance

### Burner and Burner Compartment

It is important to keep the burner and the burner compartment clean. At least once per year the burner compartment should be vacuumed and wiped out.

### Cleaning the Standing Pilot Control System

The burner and control system consists of

- burner tube
- pilot assembly
- gas valve
- gas orifice

Most of these components may require only an occasional checkup and cleaning and some may require adjustment. **If repair is necessary, it should be performed by a qualified technician.**



### Fireplace May Be HOT!!

1. Turn off pilot light at remote wall switch.
2. Let fireplace cool if it has been running.
3. Remove window frame assembly. (Refer to Window Frame Assembly Removal section)
4. Vacuum burner compartment especially around orifice primary air openings.
5. Visually inspect pilot. Brush or blow away any dust or lint accumulation.
6. Ignite pilot - Refer to Lighting Instructions.
7. Reinstall window frame assembly.

To obtain proper operation, it is imperative that the pilot and burner's flame characteristics are steady, not lifting or floating.

Typically, the top 3/8" or 1/2" of the thermopile should be engulfed in the pilot flame. (Fig. 42)

To adjust pilot burner; (by qualified service technician)

1. Remove pilot adjustment cap.
2. Adjust pilot screw to provide properly sized flame.
3. Replace pilot adjustment cap.

The primary air shutter is set at the factory and should only be adjusted, if necessary, by a qualified service technician.

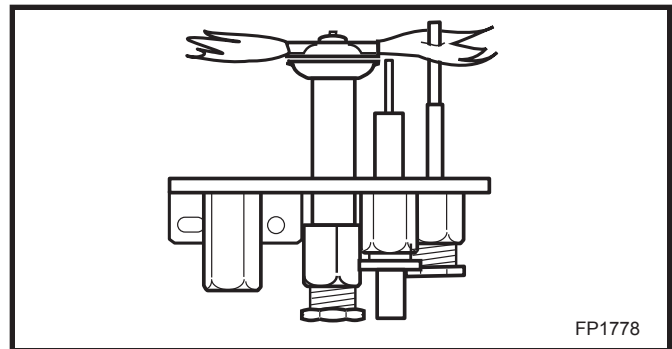
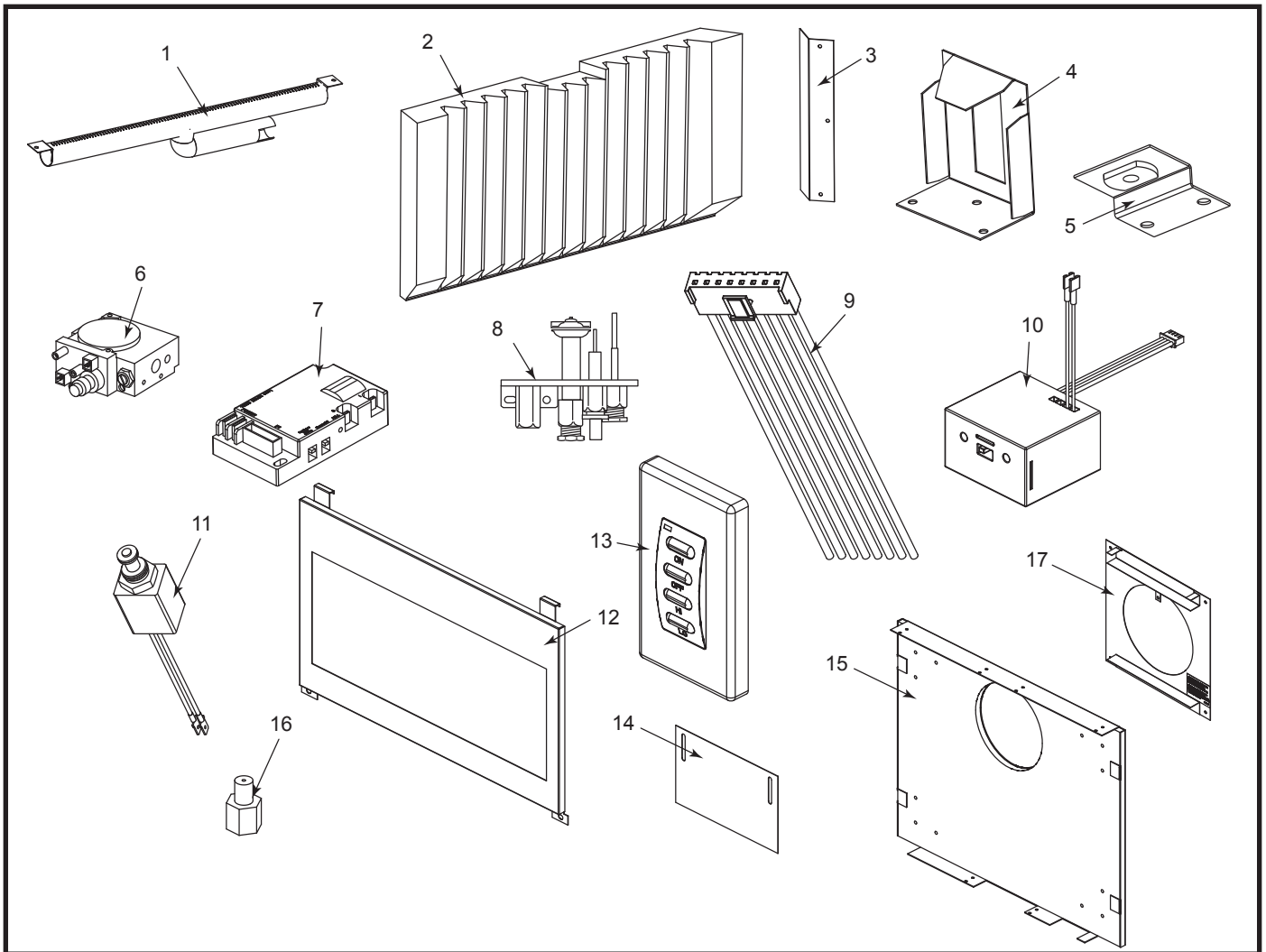

Fig. 42 Correct pilot flame appearance.





CFM Corporation reserves the right to make changes in design, materials, specifications, prices and discontinue colors and products at any time, without notice.

## DVR28IN (GFYN4G0)

Ref.	Description	DVR28
1.	Burner Tube	20012266
2.	Rear Refractory	20011551
3.	Ceramic Retainer	20012350
4.	Bracket, Upper Trim	20011581
5.	Lower Bracket Assembly	20011579
6.	Valve Assy, VF4000	20012290
7.	Main Module	20011895
8.	SIT Pilot Assembly	20012381
9.	24" Wire Harness 8-Pin, 8-Wire	20012258
10.	Battery Power Pack	20012263
11.	Solenoid Remote Hi/Lo	20012265
12.	Glass Frame Assembly	20011597
13.	On/Off HI/LO Remote Control	20012267
14.	Restrictor Plate	20012396
15.	Wall Mount Assy.	20012219
16.	Burner Orifice #45 (.0820")	20012302
17.	Firestop	20012362

## Optional Accessories

### Curve Face Kit

Model #	Color
ICVCTK04	Rustic Bronze
ICVCTK05	Charcoal

### Screen Door Kit

Model #
ICVCSTK

# LIMITED LIFETIME WARRANTY

## PRODUCT COVERED BY THIS WARRANTY

All Vermont Castings gas stoves, gas inserts, and gas fireplaces, and all Majestic brand gas fireplaces equipped with an Insta-Flame Ceramic Burner, or standard steel tube burner.

## BASIC WARRANTY

CFM Corporation (hereinafter referred to collectively as the Company) warrants that your new Vermont Castings or Majestic Gas Fireplace/Stove is free from manufacturing and material defects for a period of one year from the date of purchase, subject to the following conditions and limitations.

## EXTENDED LIFETIME WARRANTY

The heat exchanger, where applicable, and combustion chamber of every Vermont Castings or Majestic gas product is warranted for life against through wall perforation. All appliances equipped with an Insta-Flame Ceramic Burner have limited lifetime coverage on the ceramic burner plaque. Warrantees are made to the original owner subject to proof of purchase and the conditions and limitations listed on this Warranty Document

## COMPONENT WARRANTY

**CAST IRON:** All external and internal cast iron parts are warranted for a period of three years.

**Note:** On porcelain enamel finished external parts and accessories The Company offers no Warranty on chipping of enamel surfaces. Inspect all product prior to accepting it for any damage to the enamel.

The salt air environment of coastal areas or a high humidity environment can be corrosive to the porcelain enamel finish. These conditions can cause rusting of the cast iron beneath the porcelain enamel finish, which will cause the finish to flake off.

Dye lot variations with replacement parts and/or accessories can occur and are not covered by warranty.

**GLASS DOORS:** Glass doors are covered for a period of one year. Glass doors are not warranted for breakage due to misuse or accident. Glass doors are not covered for discoloration or burned in stains due to environmental issues, or improper cleaning and maintenance.

**BRASS PLATED PARTS AND ACCESSORIES:** Brass parts should be cleaned with Lemon oil only. Brass cleaners cannot be used. Mortar mix and masonry cleaners may corrode the brass finish. The Company will not be responsible for, nor will it warrant any brass parts which are damaged by external chemicals or down draft conditions.

**GAS VALVES:** Gas valves are covered for a period of one year

**ELECTRONIC AND MECHANICAL COMPONENTS:** Electronic and mechanical components of the burner assembly are covered for one year. All steel tube burners are warranted for one year.

**ACCESSORIES:** Unless otherwise noted all components and CFM Corporation company supplied accessories are covered for a period of one year.

## CONDITIONS AND LIMITATIONS

- This new Vermont Castings or Majestic product must be installed or serviced by a qualified installer, preferably NFI or WETT (Canada) certified, as prescribed by the local jurisdiction. It must be installed and operated at all times in accordance with the Installation and Operating instructions furnished with the product. Any alteration, willful abuse, accident, or misuse of the product shall nullify this warranty.
- This warranty is non-transferable, and is made to the original owner, provided that the purchase was made through an authorized supplier of the Company.
- The customer must pay for any Authorized Dealer in-home travel fees or service charges for in-home repair work. It is the dealers option whether the repair work will be done in the customer's home or in the dealer's shop.
- If upon inspection, the damage is found to be the fault of the manufacturer, repairs will be authorized at no charge to the customer parts and/or labor.

- Any part and/or component replaced under the provisions of this warranty is covered for six months or the remainder of the original warranty, whichever is longest.
- This warranty is limited to the repair of or replacement of part(s) found to be defective in material or workmanship, provided that such part(s) have been subjected to normal conditions of use and service, after said defect is confirmed by the Company's inspection.
- The company may, at its discretion, fully discharge all obligations with respect to this warranty by refunding the wholesale price of the defective part(s)
- Any installation, labor, construction, transportation, or other related costs/expenses arising from defective part(s), repair, replacement, or otherwise of same, will not be covered by this warranty, nor shall the Company assume responsibility for same. Further, the Company will not be responsible for any incidental, indirect, or consequential damages except as provided by law.
- *SOME STATES DO NOT ALLOW FOR THE EXCLUSION OR LIMITATIONS OF INCIDENTAL AND CONSEQUENTIAL DAMAGES OR LIMITATIONS ON HOW LONG AN IMPLIED WARRANTY LASTS, SO THE ABOVE LIMITATIONS MAY NOT APPLY TO YOUR CIRCUMSTANCES. THIS WARRANTY GIVES YOU SPECIFIC RIGHTS AND YOU MAY HAVE OTHER RIGHTS WHICH VARY FROM STATE TO STATE.*
- All other warranties-expressed or implied- with respect to the product, its components and accessories, or any obligations/liabilities on the part of the Company are hereby expressly excluded.
- The Company neither assumes, nor authorizes any third party to assume on its behalf, any other liabilities with respect to the sale of this Vermont Castings or Majestic product
- The warranties as outlined within this document do not apply to chimney components or other non CFM Corporation accessories used in conjunction with the installation of this product..
- Damage to the unit while in transit is not covered by this warranty but is subject to claim against the common carrier. Contact the dealer from whom you purchased your fireplace/stove (do not operate the appliance as this might negate the ability to process the claim with the carrier).
- The Company will not be responsible for:
  - a) Down drafts or spillage caused by environmental conditions such as near-by trees, buildings, roof tops, hills, or mountains.
  - b) Inadequate ventilation or negative air pressure caused by mechanical systems such as furnaces, fans, clothes dryers, etc.
- This warranty is void if:
  - a) The fireplace has been operated in atmospheres contaminated by chlorine, fluorine, or other damaging chemicals.
  - b) The fireplace has been subjected to prolonged periods of dampness or condensation
  - c) Any damages to the fireplace, combustion chamber, heat exchanger or other components due to water, or weather damage, which is the result of but not limited to, improper chimney/venting installation.
  - d) Any alteration, willful abuse, accident, or misuse of the product has occurred.

## IF WARRANTY SERVICE IS NEEDED...

- 1) Contact your supplier. Make sure you have your warranty, your sales receipt, and the model/serial number of your CFM Corporation product.
- 2) DO NOT ATTEMPT TO DO ANY SERVICE WORK YOURSELF.

Canada

**ENERGUIDE**

**Look for the EnerGuide  
Gas Fireplace Energy  
Efficiency Rating in this brochure**

*Based on CSA P.4.1-02*

<b>Efficiency Ratings</b>				
<b>Model</b>	<b>EnerGuide Ratings Fireplace Efficiency (%)</b>	<b>Steady State (%)</b>		<b>D.O.E. (AFUE%)</b>
		<b>Fan-OFF</b>	<b>Fan-ON</b>	
DVR28IN	67.6	85	n/a	64.3



**NATIONAL  
FIREPLACE  
INSTITUTE**  
**NFI**  
**CERTIFIED**  
[www.nficertified.org](http://www.nficertified.org)

We recommend that our gas hearth products be installed and serviced by professionals who are certified in the U.S. by the National Fireplace Institute® (NFI) as NFI Gas Specialists.

**CFM Corporation**

410 Admiral Blvd. • Mississauga, Ontario, Canada L5T 2N6  
800-668-5323 • [www.cfmcorp.com](http://www.cfmcorp.com)