

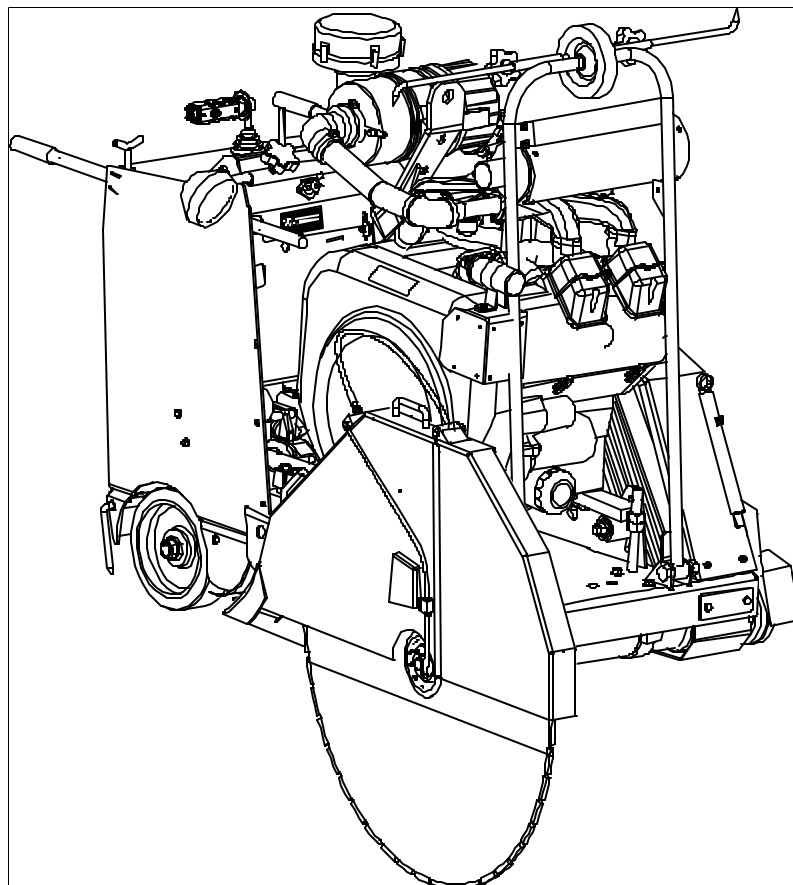

# MULTIQUIP

## SP-6065 Concrete Saw



## Operation Manual

Revision #0 (04/23/03)

# **FOR HELP & INFORMATION CONTACT MULTIQUIP**

**Please have the Model and Serial Number on-hand when calling.**

<b>MAIN (M-F 7AM-5PM) (PACIFIC STANDARD TIME)</b>	<b>MULTIQUIP INC. 18910 WILMINGTON AVE. CARSON, CALIFORNIA 90746 800-421-1244 or 310-537-3700</b>
<b>PARTS DEPARTMENT</b>	<b>800-427-1244 or 310-537-3700 FAX: 800-672-7877 or 310-637-3284</b>
<b>SERVICE DEPARTMENT/ TECHNICAL ASSISTANCE</b>	<b>800-428-1244 or 310-537-3700 FAX: 310-537-1173</b>
<b>WARRANTY DEPARTMENT</b>	<b>888-661-4279 or 310-661-4279 FAX: 310-537-1173</b>
<b>E-MAIL</b>	<b>Mq@multiquip.com</b>
<b>WEBSITE</b>	<b>www.multiquip.com</b>

## Conventions

Throughout this manual, the following conventions are used to indicate important information.

 <b>NOTE</b>	Text set off like this presents clarifying information, specific instructions, commentary, sidelights, or interesting points of information.
--	--

 <b>CAUTION</b>	Text set off like this indicates that failure to follow directions could result in damage to equipment.
---	---

 <b>WARNING</b>	Text set off like this indicates that failure to follow directions could result in bodily harm or loss of life.
---	---

 <b>NOTE</b>	It is extremely important that the operator reads and understands the safety and message section of this manual.
--	--



# WARNING



## CALIFORNIA – Proposition 65 Warning

Engine exhaust and some of its constituents, and some dust created by power sanding, sawing, grinding, drilling and other construction activities contain chemicals known to the State of California to cause cancer, birth defects and other reproductive harm. Some examples of these chemicals are:

- Lead from lead-based paints.
- Crystalline silica from brick.
- Cement and other masonry products.
- Arsenic and chromium from chemically treated lumber.

Your risk from these exposures varies, depending on how often you do this type of work. To reduce your exposure to these chemicals: ALWAYS work in a well-ventilated area, and work with approved safety equipment, such as duct masks that are specially designed to filter out microscopic particles.

# TABLE OF CONTENTS

---

---

CONVENTIONS.....	3
<b>SAFETY.....</b>	<b>7</b>
<b>OPERATION .....</b>	<b>19</b>
BEFORE STARTING.....	19
ENGINE POWER, CUTTING POWER & SHEAVE SIZE .....	20
<i>Blade RPM vs Surface Feet Per Minute (SFPM)</i> .....	22
<i>Installing the Blade</i> .....	24
<i>Stacking Blades for Wide Cuts</i> .....	24
<i>Installing and Removing the Blade Guard</i> .....	26
<i>Installing the Collar Guard</i> .....	27
WATER SUPPLY AND CONTROL .....	28
CONTROL PANEL.....	29
HANDLEBARS.....	30
FUELING THE SAW .....	31
STARTING AND STOPPING THE ENGINE .....	32
COLD WEATHER OPERATION.....	<b>ERROR! BOOKMARK NOT DEFINED.</b>
<i>Glow Plugs</i> .....	<i>Error! Bookmark not defined.</i>
<i>Block Heaters</i> .....	33
<i>Draining the Water System</i> .....	33
POINTER ADJUSTMENT.....	33
RAISE — LOWER CONTROLS .....	35
SETTING THE DEPTH INDICATOR.....	35
SETTING THE DEPTH STOP.....	36
DRIVE SYSTEM .....	37
<i>Transaxle</i> .....	38
NIGHT LIGHT .....	39
TRANSPORTATION TIE-DOWNS AND LIFT POINT.....	39
<i>Tie-Downs</i> .....	40
<i>Lift Point</i> .....	41

<b>MAINTENANCE.....</b>	<b>41</b>
REMOVABLE GUARDS AND ACCESS PANELS.....	41
BELTS AND PULLEYS.....	42
<i>V-Belt Tension</i> .....	42
<i>Adjusting BladeShaft Drive Belt Tension</i> .....	43
<i>Replacing the BladeShaft Belt:</i> .....	44
<i>Replacing the Jackshaft Belt</i> .....	44
<i>Rotary Belt Tensioner</i> .....	46
BLADESHAFT MAINTENANCE.....	46
<i>BladeShaft Replacement</i> .....	46
BLADE COLLAR REMOVAL/INSTALLATION.....	47
CIRCUIT BREAKERS.....	50
MAXIMUM CUT DEPTH ADJUSTMENT.....	50
LUBRICATION.....	51
ENGINE.....	52
<i>Air and Oil Filter Chart</i> .....	52
PTO DRIVE MAINTENANCE.....	53
REPLACING THE BATTERY.....	55
RAISE-LOWER SYSTEM.....	56
JOYSTICK TENSION ADJUSTMENT.....	57
HYDRAULIC SYSTEM MAINTENANCE.....	58
<i>Routine Maintenance</i> .....	58
<i>Draining &amp; Filling the Hydraulic System</i> .....	59
<i>Bleeding the Depth Stop Cylinder</i> .....	61
DRIVE WHEEL ALIGNMENT.....	62
<b>SPECIFICATIONS .....</b>	<b>64</b>
<b>DIMENSIONS AND WEIGHTS.....</b>	<b>65</b>
<b>WIRING DIAGRAM .....</b>	<b>66</b>

# SAFETY

---

## FOR YOUR SAFETY AND THE SAFETY OF OTHERS!

 NOTE	This Owner's Manual has been developed to provide complete instructions for the safe and efficient operation of the Multiquip SP-6065 CONCRETE SAW. For engine maintenance information, please refer to the engine manufacturers instructions for data relative to its safe operation. <b><u>Before using this CONCRETE SAW, ensure that the operating individual has read and understands all instructions in this manual.</u></b>
---	--

Safety precautions should be followed at all times when operating this equipment. Failure to read and understand the Safety Messages and Operating Instructions could result in injury to yourself and others.

### SAFETY MESSAGE ALERT SYMBOLS

The three (3) Safety Messages shown below will inform you about potential hazards that could injure you or others. The Safety Messages specifically address the level of exposure to the operator, and are preceded by one of three words: **DANGER**, **WARNING**, or **CAUTION**.



**DANGER:** You **WILL** be **KILLED** or **SERIOUSLY** injured if you **DO NOT** follow directions.



**WARNING:** You **CAN** be **KILLED** or **SERIOUSLY** injured if you **DO NOT** follow directions.



**CAUTION:** You **CAN** be injured if you **DO NOT** follow directions.

Potential hazards associated with SP-6065 Concrete Saw operation will be referenced with "**Hazard Symbols**" which appear throughout this manual, and will be referenced in conjunction with Safety "**Message Alert Symbols**".

## HAZARD SYMBOLS



### Lethal Exhaust Gases



Engine exhaust gases contain poisonous carbon monoxide gas is colorless and odorless, and can cause death if inhaled. **NEVER** operate this equipment in a confined area or structure that does not provide ample free flow air.



### Explosive Fuel



Motor fuels are highly flammable, and can be dangerous if mishandled. **DO NOT** start the engine near spilled fuel or combustible fluids. **DO NOT** fill the fuel tank while the engine is running or hot. **DO NOT** overfill tank, since spilled fuel could ignite if it comes into contact with hot engine parts or sparks from the ignition system. Store fuel in approved containers, in well-ventilated areas and away from sparks and flames. **NEVER** use fuel as a cleaning agent.



### Burn Hazards



Engine components can generate extreme heat. To prevent burns, **DO NOT** touch these areas while the engine is running or immediately after operations. **NEVER** operate the engine with heat shields or heat guards removed.



### Rotating Parts



**NEVER** operate equipment with covers, or guards removed. Keep **fingers, hands, hair** and **clothing** away from all moving parts to prevent injury.



### Accidental Starting



**ALWAYS** place the engine **ON/OFF** switch in the **OFF** position, when the saw is not in use.





## Guards and Covers



**NEVER** operate the saw without blade guards and covers in place. Adhere to safety guidelines ANSI American National Standards Institute, OSHA or other applicable local regulations.



## Rotating Blades

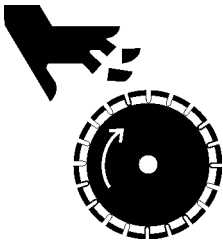

Rotating blade can cut and crush. Keep hands and feet clear.



## Respiratory Hazard



**ALWAYS** wear approved respiratory protection.



## Sight and Hearing Hazard

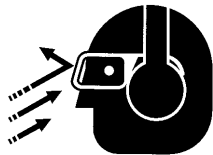

**ALWAYS** wear approved eye and hearing protection.



### Skin Injection Hazard



**NEVER** use your hand to find hydraulic leaks. Use a piece of wood or cardboard. Hydraulic fluid injected into the skin must be treated by a knowledgeable physician immediately or severe injury or death can occur.



### Over Speed Conditions



**NEVER** tamper with the factory settings of the engine governor or engine settings. Personal injury and damage to the engine or equipment can result if operating in speed ranges above maximum allowable.



### Equipment Damage Messages

Other important messages are provided throughout this manual to help prevent damage to your concrete saw, other property, or the surrounding environment.



#### **NOTE**

This *concrete saw*, other property, or the surrounding environment could be damaged if you do not follow instructions.

# RULES FOR SAFE OPERATION

Most accidents involving product operation, maintenance and repair are caused by failure to observe basic safety rules and precautions. Accidents can often be avoided by recognizing potentially hazardous situations *before* an incident occurs.

## General Safety Warnings

 <p><b>WARNING</b></p>	<ul style="list-style-type: none"><li>▪ DO NOT operate or service this equipment before reading this entire manual. Failure to follow instructions may lead to serious injury or death.</li><li>▪ This equipment is to be operated by trained and qualified personnel only. This equipment should not be operated by persons under 18 years of age.</li><li>▪ This equipment is for industrial use and to be used for its intended purpose only.</li><li>▪ NEVER operate this equipment when not feeling well due to fatigue, illness or taking medicine.</li><li>▪ NEVER operate the saw under the influence of drugs or alcohol.</li><li>▪ NEVER use accessories or attachments, which are not recommended by Multiquip for this equipment. Damage to the equipment and/or injury to user may result. Manufacturer does not assume responsibility for any accident due to equipment modifications. Unauthorized equipment modification will void all warranties.</li><li>▪ NEVER operate this saw without proper protective clothing; shatterproof glasses, steel-toed boots, respiration mask, and any other protective devices required by the job.</li></ul> <div data-bbox="516 1558 1409 1717"></div>
---	--



## **WARNING**

- Before operating the saw, make sure all protective guards are securely in place. All saws are supplied with a blade guard, collar guard and belt guard.
- Whenever necessary, replace operation and safety decals if they become difficult to read.
- Verify the engine start switch is set to the OFF position before installing a blade.
- Make sure the operator knows how to turn the engine OFF in case of an emergency.
- Do not go near rotating parts (blades, belts, pulleys or wheels) while engine is running.
- Catalytic muffler and exhaust gases are extremely hot. Stay clear of muffler and exhaust gases. Allow these parts to cool before servicing the saw.
- Stay clear of the saw while it is being hoisted.
- Anytime the saw is lifted onto its nose, or tilted fully back, for maintenance access, the high end **MUST** be blocked up to prevent the possibility of crush injury!
- Allow the engine to cool before adding fuel or performing service and maintenance functions. Contact with **HOT** components can cause serious burns.
- Never operate the saw in any enclosed or narrow area where free flow of air is restricted. If the air flow is restricted it will cause serious damage to the saw's engine and may cause injury to people. Remember the saw's engine gives off **DEADLY** carbon monoxide gas.
- **ALWAYS** refuel in a well-ventilated area; away from sparks and open flame. Avoid "topping off" the filler port as spills can result.
- **ALWAYS** use extreme caution when working with flammable liquids. When refueling, **STOP** the engine and allow it to cool.
- **NEVER** smoke around or near the machine. Fire or explosion could result from fuel vapors, or if fuel is spilled on a **HOT** engine.
- **NEVER** operate the saw in an explosive atmosphere where fumes are present or near combustible materials. An explosion or fire could result causing severe bodily harm or even death.
- **NEVER** use fuel as a cleaning agent.

## General Safety Precautions



### CAUTION

- ALWAYS read, understand, and follow procedures in the Operator's Manual before attempting to operate the equipment.
- Be sure the operator is familiar with proper safety precautions and operating techniques before using the saw.
- Make sure the operating area is clear before starting the engine.
- Maintain this equipment in a safe operating condition at all times.
- Keep the saw clean. It will work better and last longer.
- Use proper blades and follow the blade manufacturer's recommendations. Match blade rpm (Blade Shaft rpm) to recommended blade surface feet per minute (SFPM).
- Tighten the 5/8" blade-mounting bolt to 100-125 foot-lbs. torque.
- Turn engine OFF prior to fueling the saw.
- Start engine with the joystick in NEUTRAL to prevent unexpected saw movement.
- Do not leave saw unattended while engine is running.
- Do not start engine on a sloping surface to prevent unexpected loss of control.
- Do not park or leave saw unattended on a slope - the saw can roll when the engine is OFF. Block the unit when leaving.
- If the saw must be parked on a slope, turn it across the angle of the slope, to prevent accidental downhill movement.
- Always store equipment properly when not being used. Equipment should be stored in a clean, dry location out of the reach of children. When storing the saw in freezing weather, blow out water lines to prevent damage to components in the water delivery system.
- Prior to service, level the frame surface.
- Do not over tighten the Blade Shaft drive belt.
- Turn on water flow prior to starting the engine, to prevent damage to the impeller of a belt-driven water pump.
- Don't pollute! Waste oils and other chemicals must be disposed of in a manner consistent with local and state environmental protection regulations.

## BLADE SAFETY



### WARNING

- ALWAYS inspect diamond blades before each use. The blade should exhibit no cracks, dings, or flaws in the steel centered core and/or rim. Center (arbor) hole must be undamaged and true.

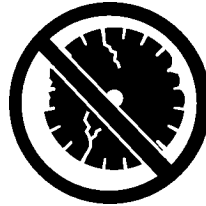







- Examine blade flanges for damage, excessive wear and cleanliness before mounting blade. Blade should fit snugly on the shaft and against the inside/outside of the saw.
- Only cut the material that is specified by the blade. Read the specifications of the blade to ensure the proper tool has been matched to the material being cut.
- ALWAYS keep blade guards in place. Exposure of the blade must not exceed 180 degrees.
- Ensure that the blade does not come into contact with the ground or surface during transportation. DO NOT drop the blade on the ground or surface.
- The engine governor is designed to permit maximum engine speed in a no-load condition. Speeds that exceed this limit may cause the blade to exceed the maximum safe allowable speed.
- Ensure that the blade is mounted for proper operating direction.

# SAW TRANSPORTATION SAFETY

 <p><b>CAUTION</b></p>	<ul style="list-style-type: none"><li>▪ Use appropriate lifting equipment to ensure the safe movement of the saw.</li><li>▪ DO NOT use the handle bars and/or front pointer as lifting points.</li><li>▪ NEVER attempt to tow the untrailerred saw behind a vehicle.</li><li>▪ NEVER transport the saw with the blade mounted.</li></ul>
---	--

## EMERGENCIES

	<ul style="list-style-type: none"><li>▪ ALWAYS know the location of the nearest <b>fire extinguisher</b>.</li><li>▪ ALWAYS know the location of the nearest <b>first aid kit</b>.</li><li>▪ In emergencies always know the location of the nearest <b>phone</b> or keep a phone on the job site.</li></ul> <p>Also know the phone numbers of the nearest <b>ambulance</b>, <b>doctor</b>, and <b>fire department</b>. This information will be invaluable in the case of an emergency.</p>      
--	--





# Serial Tag



Fig. 1 — Serial Tag

 <b>NOTE</b>	For future reference, fill in the model number and serial number of your saw in the spaces on the label above.
--	--

The serial tag contains the model number and serial number of the saw. This information details all parts that were included with the saw when it was shipped from the factory, as well as the date of manufacture.

Record your **ENGINE** model, specification number and serial number here:

<b>MODEL NO.</b>	<b>SPEC. NO.</b>	<b>SERIAL NO.</b>

The **SERIAL TAG** is bonded to the panel forward of the console, (between the console and the engine).

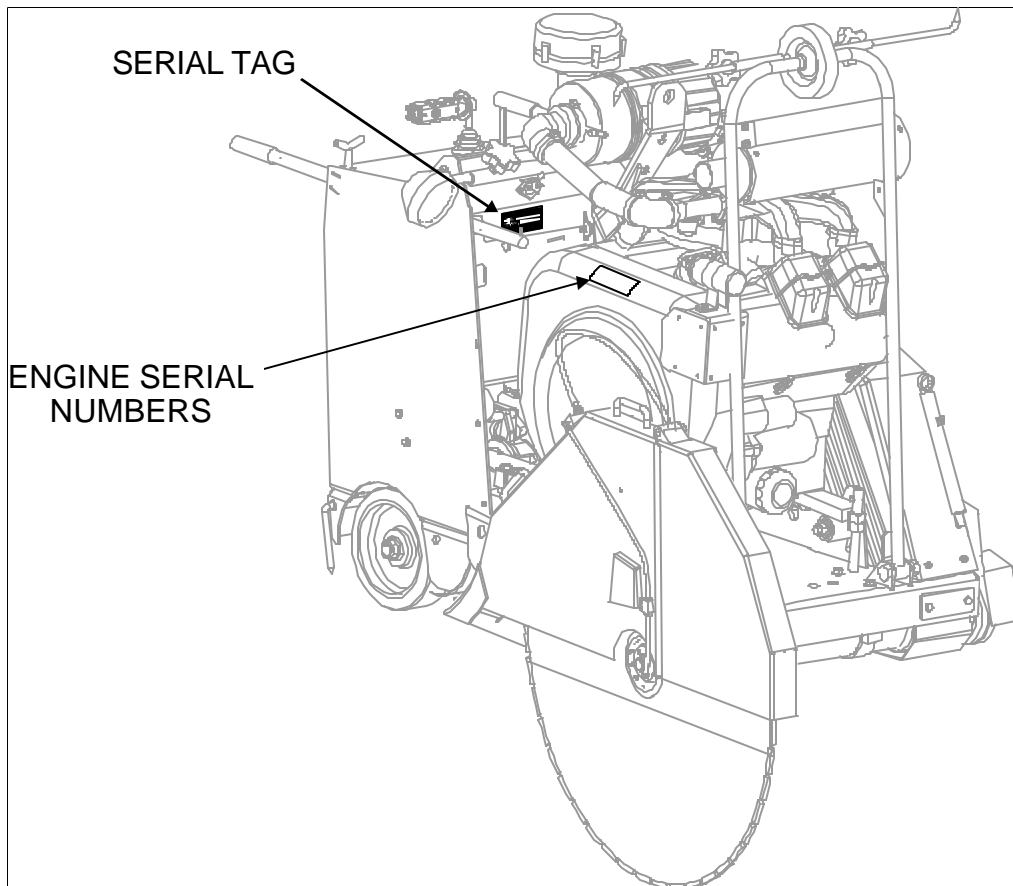

**Fig. 2 — Serial Number Locations**



**NOTE**

- The 5/8" blade-mounting bolt on the right side of the saw (as viewed from the operator's position) has a left hand thread, while the blade-mounting bolt on the left side of the saw has a right hand thread.
- Most saw hardware is measured in English (inch) units. The Illustrated Parts List notes any Metric hardware. Be sure to use the correct hardware and proper tools.

# OPERATION

---

## Before Starting

Before starting the saw, carefully follow the checklist below:

- Securely install the Belt Guard (2).
- Fully slide on the Collar Guard (3).
- Verify that proper-sized Blade Guard (4) is fully installed on the Blade Guard mounting tab.
- Confirm the rear and side access panels (5) & (6) and engine protector are in place.
- Wear eye and hearing protection and protective clothing.
- Adjust handle bars (1) for best operator control.
- If a *belt driven water pump* is installed, do not run the engine with the water pump switch on, unless the water supply is connected and water is flowing.

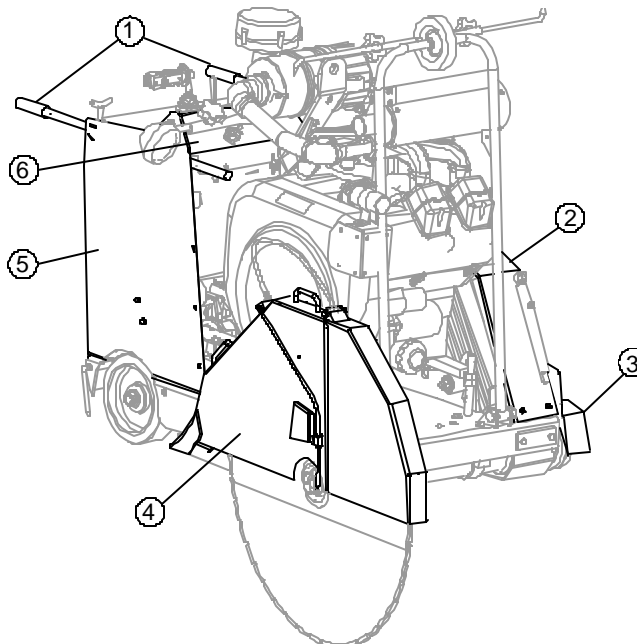

**Fig. 3 — Guards & Panels**

# Engine Power, Cutting Power & Sheave Size

The cutting capability of your saw is a relationship between engine power (as reflected in the engine RPM) and the speed (RPM) of the Blade Shaft. The gasoline engine of the SP-6065 runs at 2800 RPM (full load). If 2800 RPM was a desirable Blade Shaft speed for the average conditions in which you work, we would use the same size sheave on the engine shaft and the Blade Shaft; and the ratio between the two would be 1 : 1.

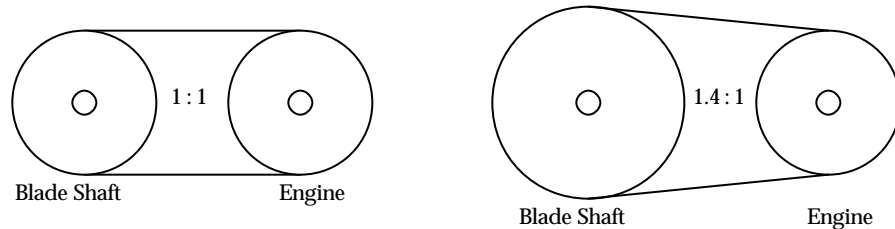

Fig. 4 — Blade Shaft Ratios

If, however, for your cutting conditions, you need a Blade Shaft speed slower than the engine speed (and this is usually the case), then we need to INCREASE the ratio between the two speeds by putting a larger diameter sheave on the Blade Shaft.

If, for example, you know from experience that you need a Blade Shaft speed of 2000 RPM for the size of blade you normally use (see the Blade RPM vs. SFPM Chart, below):

$$2800 \text{ (engine RPM)} \div 2000 \text{ (desired BS RPM)} = 1.4$$

This is the ratio 1.4 : 1, which means that for every 1.4 revolutions of the engine, the Blade Shaft only turns once.

Ratios greater than 1 : 1 also have the beneficial effect of *increasing the torque of the Blade Shaft* by the same factor (1.4 in our example) . The manufacturer advertises that the Deutz BF31011 diesel engine develops 123 ft. lbs. of torque. To find the *theoretical* torque of our example saw setup:

$$123 \times 1.4 = 172.2 \text{ ft. lbs.}$$

Actual torque of the saw will vary somewhat. In general, more torque means more cutting power.

Typically, however, the ratios are not used to design a level of torque; they are used to create a saw with the optimum blade speed (blade Shaft RPM) for you. The major factors are:

- ◆ diameter of blade(s) you commonly use, and
- ◆ cutting conditions you work under

We can also tailor the Blade Shaft RPM (blade speed) by adjusting the “primary” ratio between the engine and the Blade Shaft. By selecting a Blade Shaft sheave and Engine sheave, a multitude of additional ratios (and Blade Shaft speeds) are possible. The following Sheave sets are available as standard kits:

Engine Sheave	Blade Shaft Sheave	Engine Spacer*	Ratio	Blade Shaft RPM	Engine RPM	MERCURY Kit #
3.6	4.75	.75	1.32 : 1	2121	2800	<b>18600</b>
3.6	5.0	.5	1.38 : 1	2028	2800	<b>18601</b>
3.6	5.3	.375	1.47 : 1	1904	2800	<b>18602</b>
4.1	4.2	.75	1.02 : 1	2735	2800	<b>18608</b>
4.1	4.4	.5	1.07 : 1	2609	2800	<b>18607</b>
4.1	4.5	.5	1.10 : 1	2545	2800	<b>18604</b>
4.1	4.75	.375	1.16 : 1	2413	2800	<b>18603</b>
4.1	5.0	.375	1.22 : 1	2295	2800	<b>18605</b>

## Blade RPM vs. Surface Feet Per Minute (SFPM)

When choosing a blade for your cutting conditions, follow the blade manufacturer's recommendations. Match the blade speed (Blade Shaft RPM) to the recommended blade Surface Feet Per Minute (SFPM).

SFPM	12" diam. RPM	14" diam. RPM	16" diam. RPM	18" diam. RPM	20" diam. RPM	24" diam. RPM	26" diam. RPM	30" diam. RPM	36" diam. RPM
8,000	2546	2183	1910	1698	1528	1273	1175	1019	849
8,500	2706	2319	2029	1804	1623	1353	1249	1082	902
9,000	2865	2456	2149	1910	1719	1432	1322	1146	955
9,500	3024	2592	2268	2016	1814	1512	1396	1210	1008
10,000	3183	2728	2387	2122	1910	1592	1469	1273	1061
10,500	3342	2865	2507	2228	2005	1671	1543	1337	1114
11,000	3501	3001	2626	2334	2101	1751	1616	1401	1167
11,500	3661	3138	2745	2440	2196	1830	1690	1464	1220
12,000	3820	3274	2865	2546	2292	1910	1763	1528	1273
12,500	3979	3410	2984	2653	2387	1989	1836	1592	1326
13,000	4138	3548	3104	2759	2483	2069	1910	1655	1378
13,500	tbd		3229	2866	2581	2149	1985	1719	1433
14,000	tbd		3349	2972	2676	2229	2058	1783	1486
14,500	tbd		3468	3078	2772	2308	2132	1847	1532

 <b>CAUTION</b>	<ul style="list-style-type: none"> <li>▪ Verify that the engine start switch is OFF before installing blade.</li> <li>▪ <b>Tighten the 5/8" blade-mounting bolt to 125-175 foot-pounds torque.</b></li> </ul>
---	---

## Installing the Blade

The blade can be mounted on either side of the saw to accommodate different cutting jobs.

1. Raise the saw so that the blade will clear the ground when installed.
2. Verify that blade collars are clean and undamaged.
3. Insert the bushing and mounting bolt through the outer collar and blade.
  - ◆ Align collar pin through the blade into the inner collar.
4. Tighten the 5/8" mounting bolt to **125-175 foot-pounds** of torque.
  - ◆ The blade-mounting bolt on the right side of the saw (as viewed from the operator's position) has a left hand-thread, while the blade-mounting bolt on the left side of the saw has a right-hand thread.

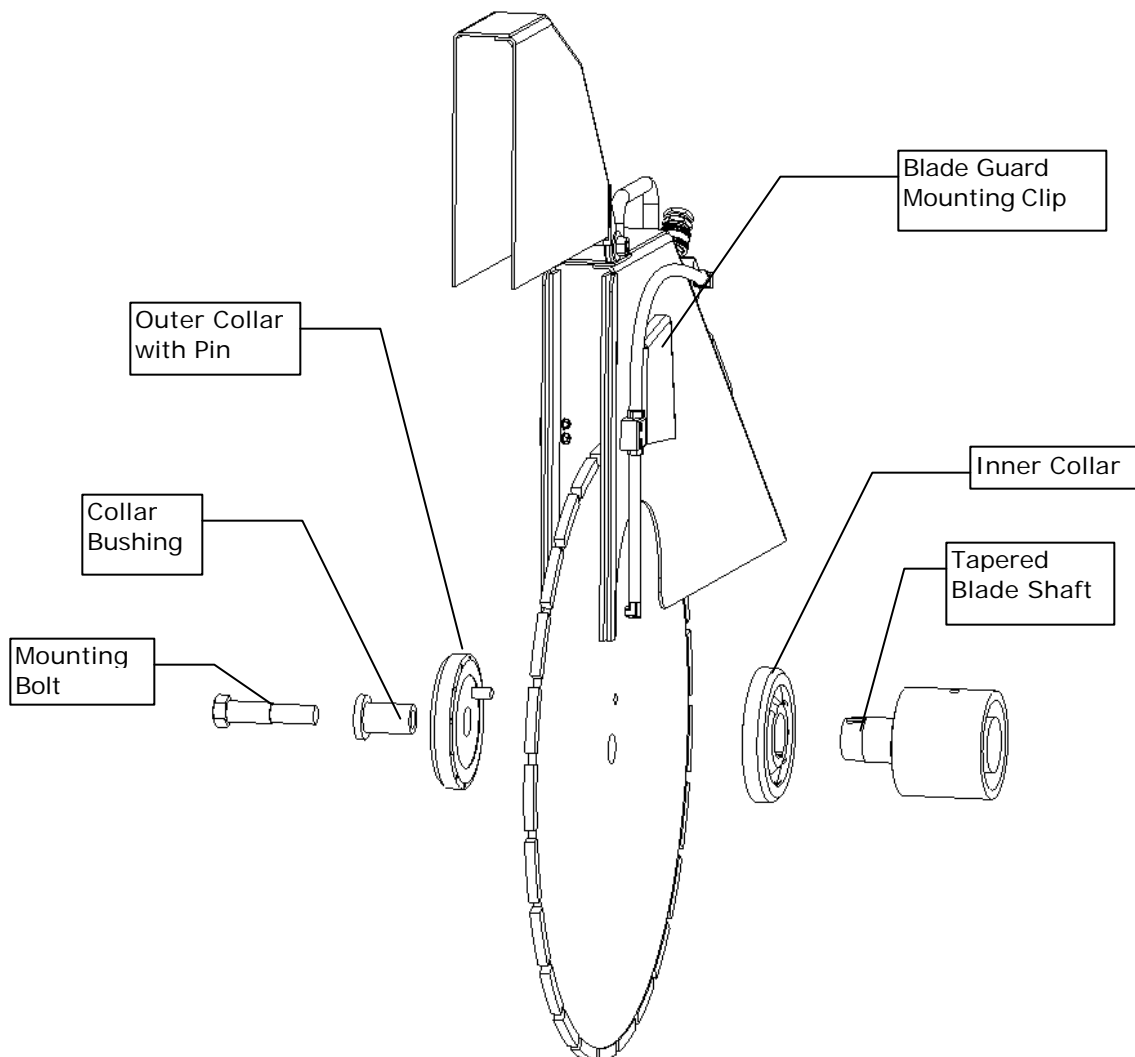



Fig. 5 — Installing the Blade

## Stacking Blades for Wide Cuts

 <b>WARNING</b>	NEVER attempt to stack blades beyond the capacity of the Kits described here. NEVER operate the saw without blade guards in place.
---	--

Combining (stacking) blades together to make wide cuts requires an optional Bushing Extension Kit.

- Kit #18501 allows blade stacking from .375" to .75" thickness.
- Kit #18502 allows blade stacking from .75" to 1.125" thickness.

The kits consist of an outer collar with a longer pin, an extended bushing, and longer bolts.

1. Remove the existing Blade (see Installing the Blade, above).
2. Replace the standard Collar Bushing, Outer Collar, and Mounting Bolt that came with the saw, with the extended Bolt and Bushing and the new Outer Collar that came with the Kit.
  - ◆ The Mounting Bolt for the right side of the saw (as seen from the operator's position) has a left hand-thread, while the Mounting Bolt for the left side of the saw has a right-hand thread.
3. Insert the Bushing and Mounting Bolt through the Outer Collar and stack of Blades. The longer bushing and bolt allow blades to be stacked together
4. Align the Collar Pin through the stack of Blades into the Inner Collar.
5. **Tighten the 5/8" Mounting Bolt to 125-175 foot-pounds of torque.**

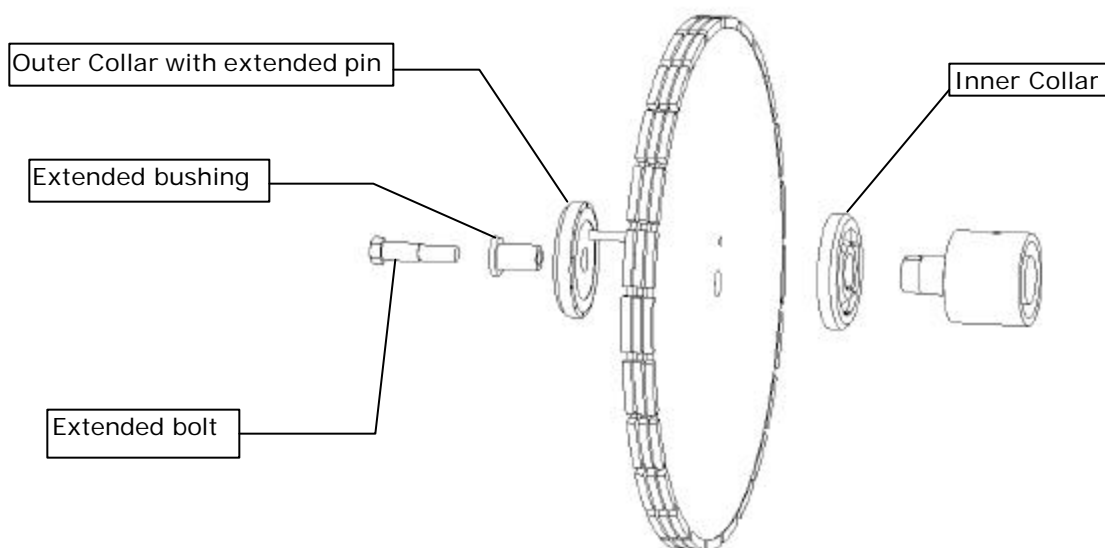

Fig. 6 — Blade Stacking



## Installing and Removing the Blade Guard

Blade Guards are “ambidextrous” – that is, they can be installed on either side of the saw.

### *Installing the Blade Guard*

1. Slide the Blade Guard Mounting Clip onto the Guard Mounting Tab on the frame.
2. Connect the water delivery hose to the Blade Guard.
  - ◆ Ensure that the water pipes are pointed toward the water distribution grooves in the Blade Collars.
3. Make sure the front-hinged section of the Blade Guard is fully closed before use.

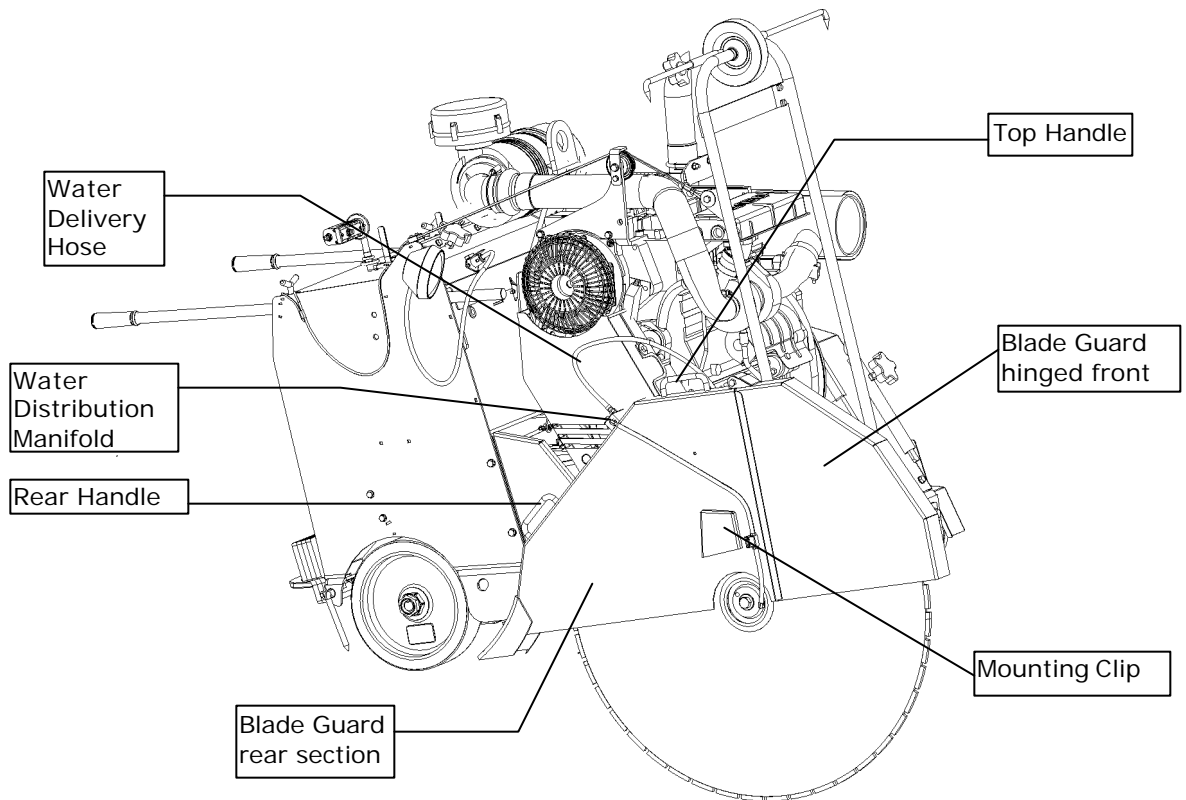
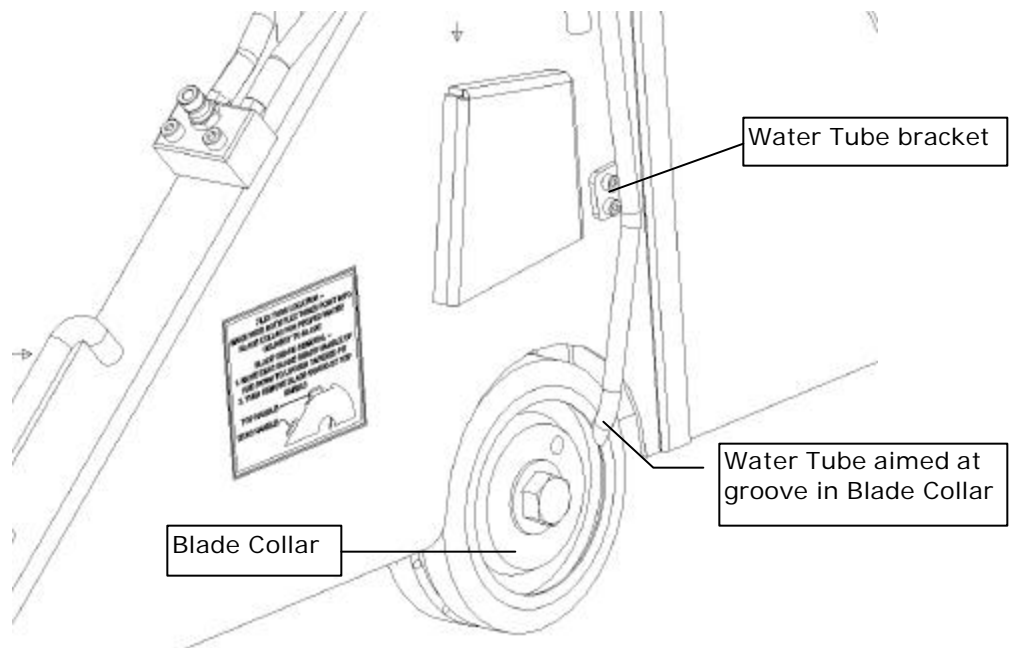

**Fig. 7 — The Blade Guard installed (Similar to illustration)**

## *Blade Guard Water Supply*

Verify that the water hose on the saw is connected to the Blade Guard and that the water pipes are pointed into both Blade Collars.

 <p><b>CAUTION</b></p>	<p>Make sure that the 90° outlets of the water tubes point toward the lower portion of the blade collars, aimed at the delivery ports, for proper water delivery to the blade.</p>
---	--



**Fig. 8 — Water Tubes and the Blade Collar**

## *Removing the Blade Guard*

During use, the Blade Guard can become tight on the tapered mounting tab. To loosen it, wiggle the Rear Blade Guard Handle up and down, while lifting with the Top Handle.

## Installing the Collar Guard

The Collar Guard protects unused Blade Collars.

1. Slide the Collar Guard (1) onto the Guard Mounting Tab on the frame.
2. Verify that the unused Blade Collar (2) is secured to the Blade Shaft, by tightening the mounting bolt (3).

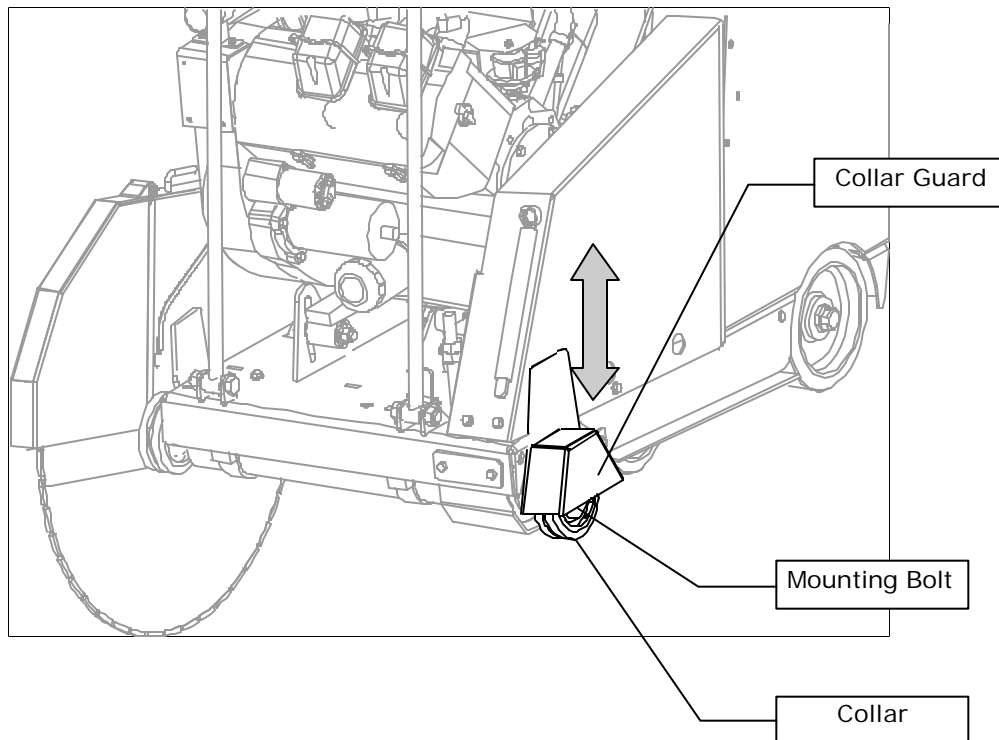

**Fig. 9 — The Collar Guard, Installed**

# Water Supply and Control

 <b>CAUTION</b>	<ul style="list-style-type: none"><li>▪ To prevent damage to the impeller of a <i>belt driven water pump</i>, do not run the engine with the water pump switch on, unless the water supply is connected and water is flowing.</li><li>▪ When storing the saw during freezing weather, blow out the water lines to prevent damage to the water delivery system.</li></ul>
---	--

1. Connect the water supply hose to the water inlet (garden hose) fitting (1) on the left side of the saw.
2. Verify that the water hose on the saw is connected to the Blade Guard (5) and that the water tubes are pointed into both Blade Collars.
3. The yellow lever (4) on left side of the control panel regulates water flow volume. The other lever (3) turns the water On and Off.
4. If the saw is equipped with an optional water pump, the ON/OFF switch (2) is on the control panel next to the water flow control valve.

 <b>NOTE</b>	<p>Because of the water delivery efficiency of the 24-port blade collars, your saw will use less water for blade lubrication than other water deliver systems.</p>
--	--

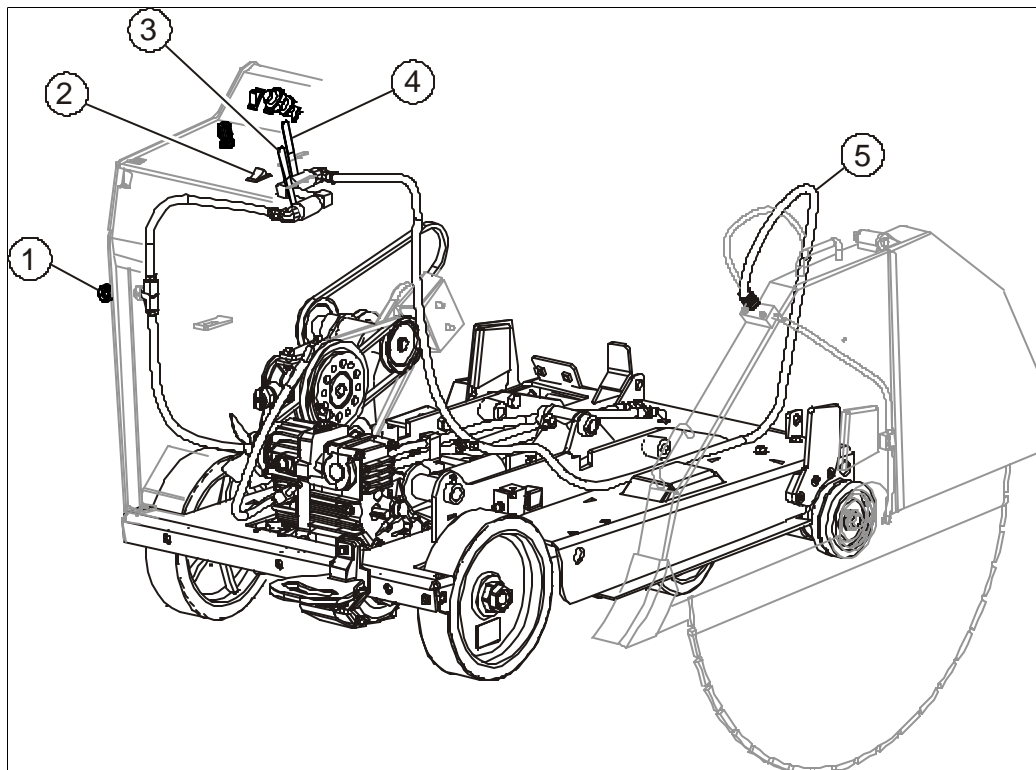

**Fig. 10 — The Water Supply System**

# Control Panel

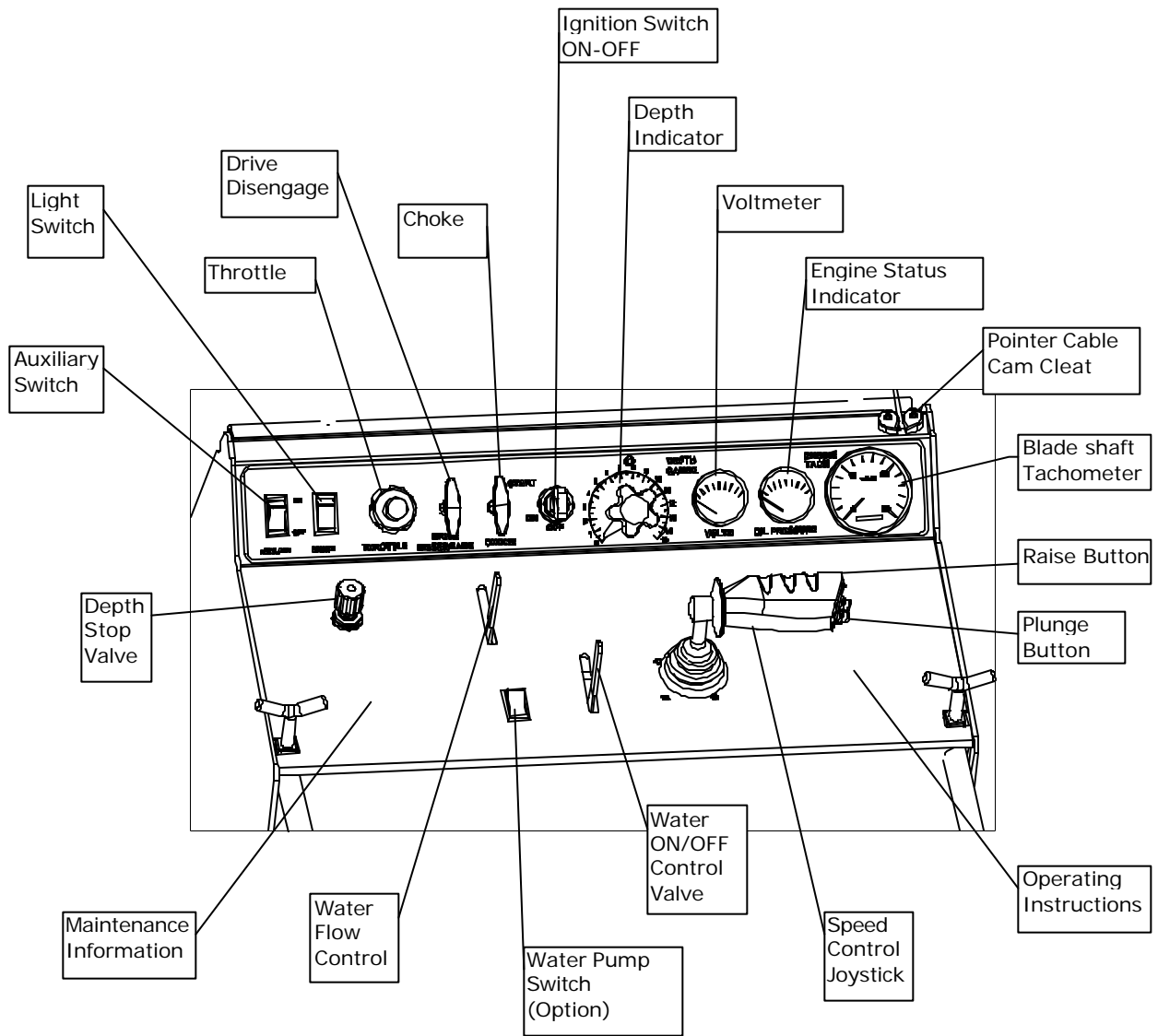

**Fig. 11 — The Control Panel**

## Handlebars

The handlebars are adjustable to three different angles, for optimum operator control, and can also be slid fully inward for storage. Once handlebars are adjusted, lock them into position by tightening the lock knob on each side.

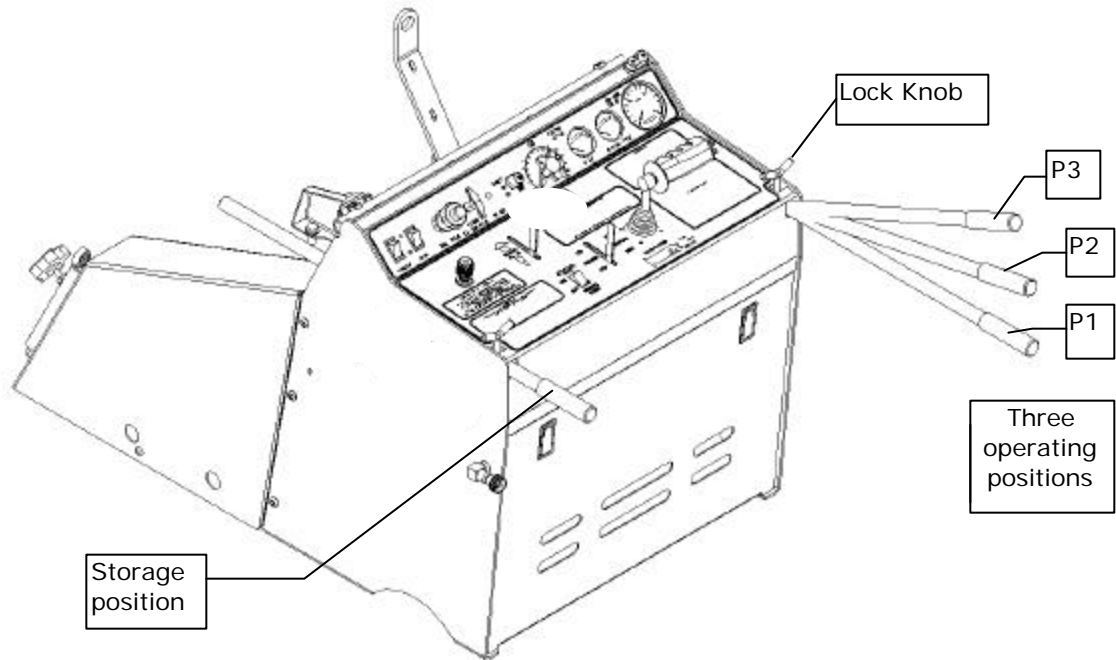



Fig. 12 — Handlebar Positions (Similar to illustration)

Using the handlebars in position #2 or #3 when employing larger diameter blades, reduces the need to bend over, and reduces the effort required by the operator to maneuver the saw.

## Fueling the Saw

The saw features a 10-gallon, clear, molded plastic fuel tank with a sight gauge, central drain, and shutoff valve. The gas tank cap is located at the front of the control console.

 <p><b>CAUTION</b></p>	<ul style="list-style-type: none"><li>▪ Be sure the engine is turned off prior to fueling the saw.</li><li>▪ Do not spill fuel on control panel or engine.</li><li>▪ Wipe up spills immediately</li><li>▪ Do not over-tighten gas cap.</li><li>▪ Use unleaded gasoline only.</li></ul>
---	--

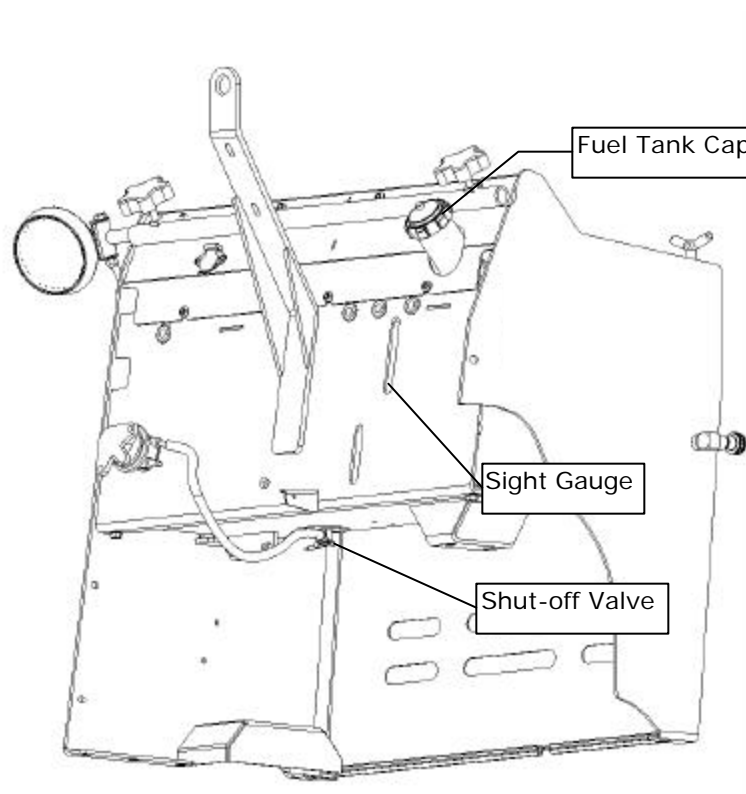



Fig. 13 — Fuel System

# Starting and Stopping the Engine

 <p><b>CAUTION</b></p>	<ul style="list-style-type: none"><li>▪ Do not leave the saw unattended while the engine is running.</li><li>▪ Do not start, park, or leave the saw unattended on a slope.</li><li>▪ If the saw has an optional water pump, <i>do not</i> run the saw dry with the water pump switch ON — otherwise the pump impellers <i>will</i> be damaged.</li><li>▪ In normal operation, <i>Do not stop the engine abruptly when hot!</i> Reduce the throttle to idle and allow the engine to run one or two minutes before turning the ignition switch off.</li></ul>
---	---

1. Move the speed control joystick to NEUTRAL position.
2. Set the throttle to one-quarter open. Pull the choke sufficiently to start the engine.
3. Ensure that water lines are attached and water is flowing to the saw.
4. Momentarily turn the start switch to the START position.
5. Push the choke in once the engine starts and allow the engine to warm up for several minutes.
6. Set the throttle to the recommended engine RPM to match the recommended blade speed of the attached blade.
7. Lower the blade to the cut depth.
8. Move the joystick FORWARD to advance the cut.
9. **To stop the engine, turn the ignition switch to the OFF position.**

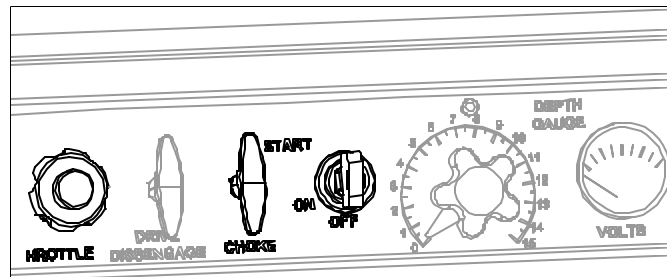



Fig. 14 — ON/OFF Switch, Choke, Throttle Locations

 <p><b>WARNING</b></p>	<ul style="list-style-type: none"><li>▪ Make sure the operator knows how to turn the engine off in case of an emergency.</li><li>▪ Do not go near rotating parts (blade, belts, pulleys, or wheels) while the saw is running.</li></ul>
---	---



## Block Heaters

Optional Block Heaters, (installed directly on the crankcase), are operated by plugging them into an electrical outlet via an extension cord. Do not use when low temperatures are above 20°F. The block heater is NOT thermostatically controlled and should be used only prior to intended use of saw.

 <p><b>CAUTION</b></p>	<ul style="list-style-type: none"><li>▪ Do not leave optional Block Heaters plugged in unattended, for extended periods or when temperatures are above 20°F. The oil could “cook” inside the crankcase and damage to the engine could result.</li><li>▪ If the Water System is not drained when the saw is not in use and temperatures fall below 32°F, damage may occur to optional water pumps and/or oil coolers.</li></ul>
---	--

## Draining the Water System

When low temperatures fall below 32°F:

1. If the saw is equipped with an optional Water Pump, open the drain petcock on the pump and allow the pump to drain.
  - ◆ With the engine running, turn the water pump switch on for a few seconds to purge water remaining inside the pump body.
2. Tilt the saw up and back, to allow water to drain.
3. Tilt the saw forward, to allow water to drain again.
4. If an air compressor is available, blow out the system by applying compressed air to the Water Inlet (see Fig. 10).

## Pointer Adjustment

1. Lower the front pointer assembly.
  - ◆ Adjust the pointer rod (1) by loosening the lock knob (2).
  - ◆ Once the pointer rod is set to the cut line, tighten the lock knob.
2. Adjust the rear pointer to the cut line:
  - ◆ Loosen the lock bolt, position the pointer rod, and tighten the lock bolt.
3. To raise the front pointer assembly, pull back and up on the pointer cable (3).
  - ◆ Secure the pointer assembly in the desired raised position by locking the cable between the jaws of the cam cleat (5).

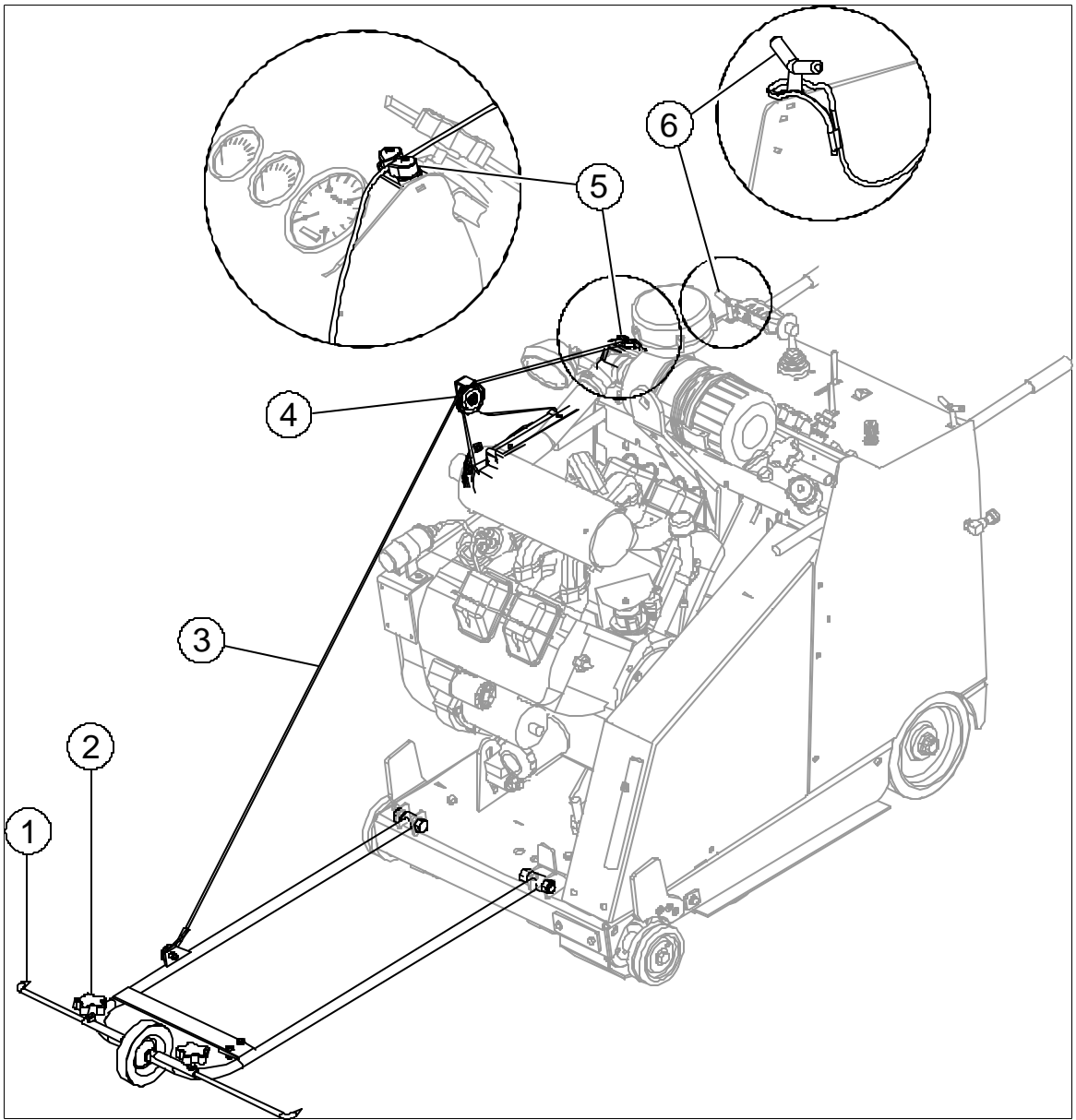

**Fig. 15 — Pointer Adjustment**

## Raise — Lower Controls

This saw uses a 12-volt hydraulic pump and cylinder to raise and lower the blade. The SP 6065 saw has a plunge button and a raise button. Controls are located on the joystick handle.

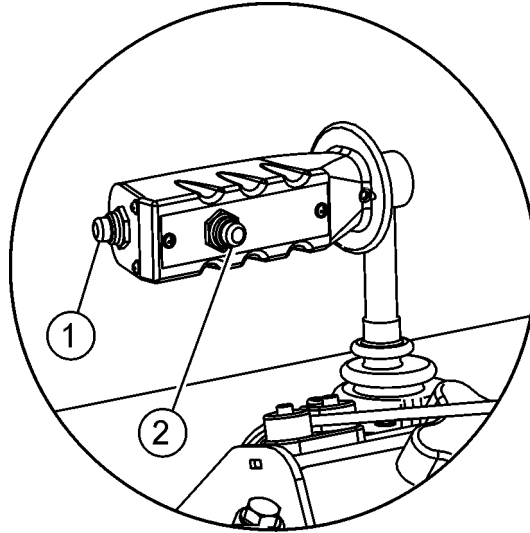

Fig. 16 — Joystick Handle - Controls

1. To lower the blade to the cut, push the button on the end of the handle (1).
2. To lift the blade, hold down the Raise button on the side of the handle (3).

See the Maintenance section of this manual for an illustration of the Raise-Lower System components, and troubleshooting techniques.

## Setting the Depth Indicator

1. Lower the blade until it just touches the cutting surface.
2. Set the Depth Indicator dial to zero. (The Depth Indicator now accurately indicates how deep the blade is cutting.)

## Setting the Depth Stop

This saw uses a hydraulic Depth Stop to position and lock the blade at the desired cut depth.

1. With the blade raised several inches off the ground, open the Depth Stop Valve to allow the cylinder to “pump out”.
2. Close the Depth Stop Valve. The system is now “preloaded” and ready to complete setting the desired cutting depth.
3. While holding the Lowering Button and viewing the Depth Indicator, slowly reopen the Depth Stop Valve and use it to control the lowering of the blade to the desired depth as observed on the Depth Indicator.
4. When the desired depth is achieved close the Depth Stop Valve and release the Lowering Button.
5. The saw will now repeatedly lower to the set cutting depth whenever the Lowering Button is depressed.
6. If a different cutting depth is desired repeat these steps resetting to desired cutting depth.

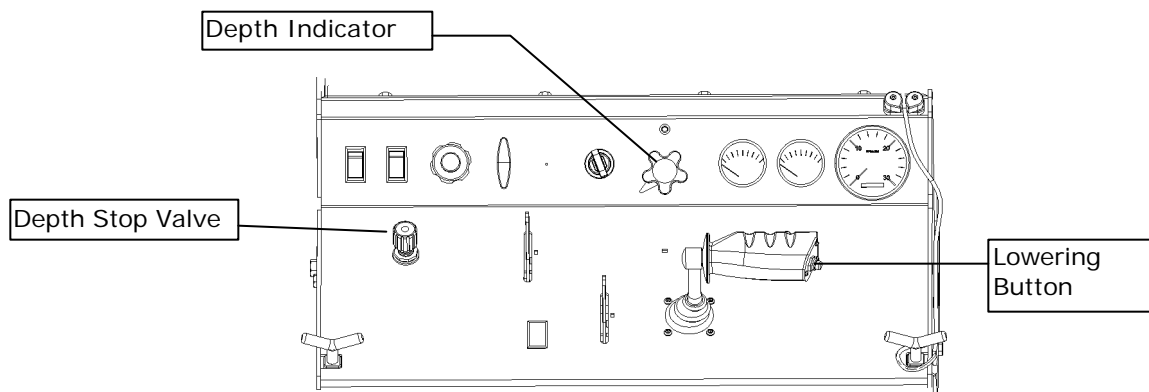



Fig. 17 — Setting the Depth Gauge and Depth Stop (Similar to illustration)

To disable the Depth Stop when it is not needed:

1. Open the Depth Stop Valve.
2. Set the Blade Collars on the ground.
3. Close the Depth Stop Valve.

 <b>CAUTION</b>	<p><i>Do not cut with the Depth Stop Valve in the OPEN position; this could cause the blade to rise out of the cut.</i></p>
---	---

## Drive System

This saw has a cable-controlled Hydro-Gear hydrostatic powered transaxle with infinite F-N-R speed adjustment via a joystick controller. The saw is designed with locked axle drive, and can travel at speeds up to 300 feet per minute.

### Drive System Controls

The panel-mounted joystick controls FORWARD-NEUTRAL-REVERSE (F-N-R) and infinitely variable speeds in both directions. To increase forward speed, slowly move the joystick FORWARD. Pulling the joystick backward decreases saw speed, and when the joystick passes NEUTRAL the saw moves into REVERSE. Reverse speed is also controlled by the position of the joystick.

The Drive Disengage handle, when pulled, puts the saw in “free wheeling” mode. This is not a “true” Neutral, but does provide a by-pass in the pump/motor group that allows the saw to be readily moved. Some rolling resistance will be encountered.

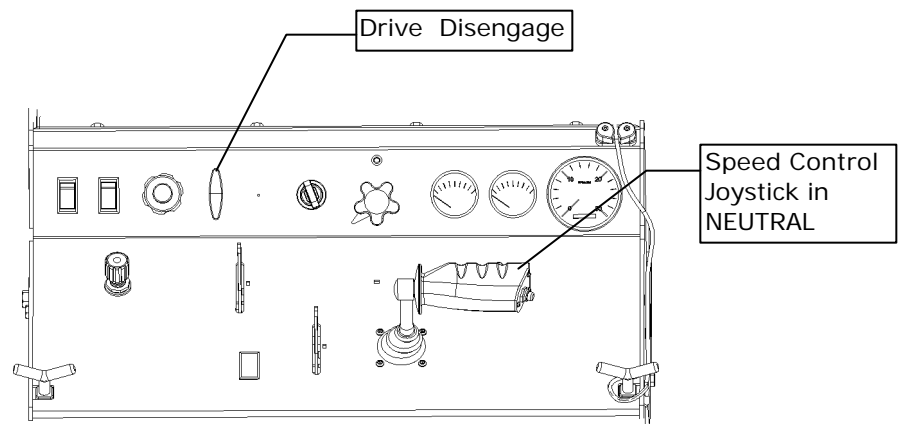

Fig. 18 — Drive System Controls (Similar to illustration)

## Transaxle

The Hydro-Gear hydrostatic-powered transaxle has no chains, sprockets or open gears to service. There is a simple cable control. The remote filter promotes long life and easy maintenance.

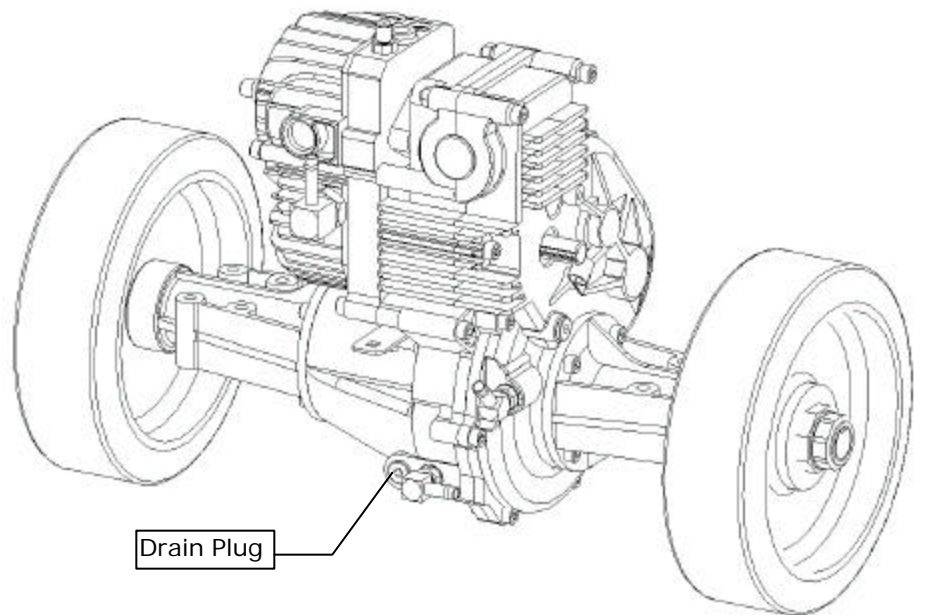

Fig. 19 — The Transaxle

## Night Light

The night light can be used on either side of the saw, and can be extended and rotated for best illumination of the cutting area. Aim the light, then lock it in position by tightening the lock knobs. The light can be removed for storage by loosening the lock knobs, disconnecting the light cord and sliding the light bar out of the saw.

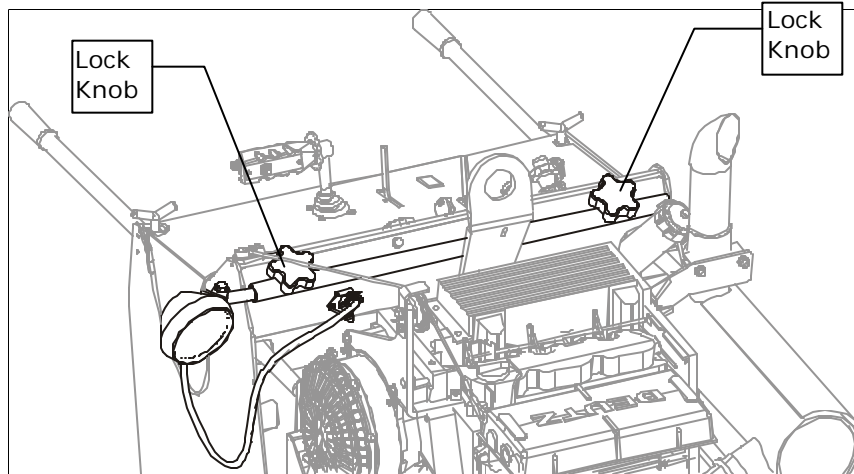

Fig. 20 — Night Light (Similar to illustration)

## Transportation Tie-downs and Lift Point

### Tie-downs

The saw is provided with holes at each corner of the lower frame for easy tie-down during transportation. The ½” all-thread J-bolts, with which your saw was attached to its shipping pallet, can be used in a variety of tie-down scenarios.

*It is highly recommended that the saw be tied down any time it is being transported.*

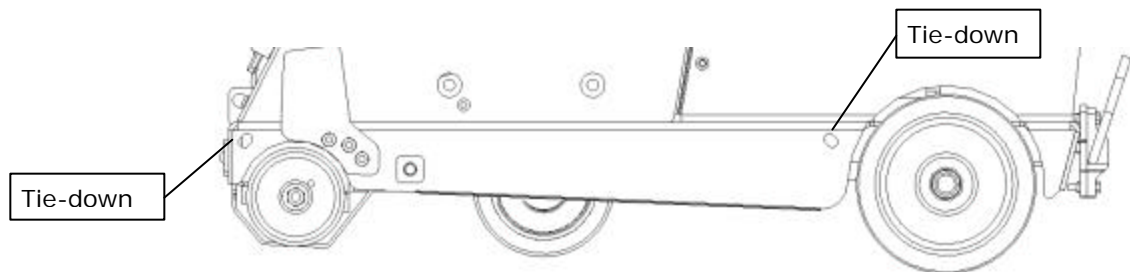

Fig. 21 — Tie-down Points

## Lift Point

The convenient single point for lifting the saw with a hoist is located just in front of the console, between it and the engine.

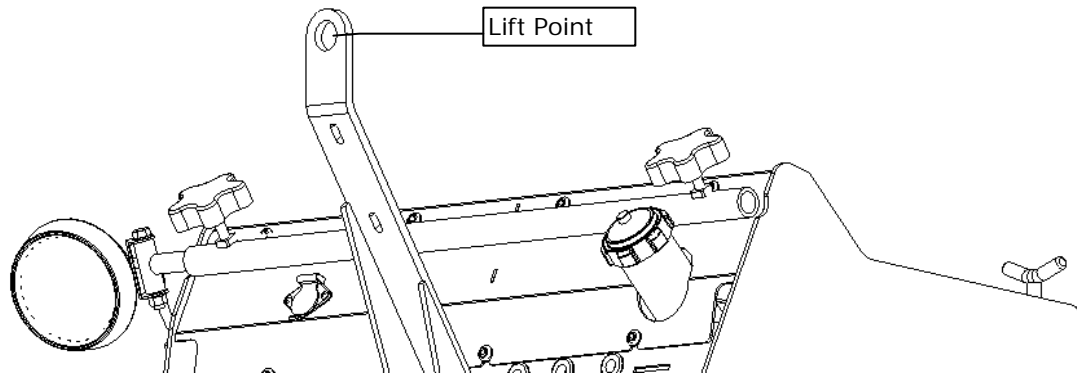

Fig. 22 — Lift Point



### **WARNING**

- To avoid possible injury, stay clear of the saw while it is being hoisted.
- To avoid possible damage to the saw, use approved rigging (minimum 2000 lb. test) when hoisting the saw.



# MAINTENANCE

---

---

This saw has many service-saving features, such as fully enclosed oil bath lubricated Blade Shaft bearings, which require no daily lubrication.



## NOTE

Level the saw frame surface prior to service to get accurate oil level readings.

## Removable Guards and Access Panels

For ease of service access, the following guards and panels are removable:

- Blade Guard (4)
- Rear Access Panel (5)
- Console Access Panel (6)
- Belt Guard (2)
- Collar Guard (3)

Replace guards and panels prior to starting the engine.

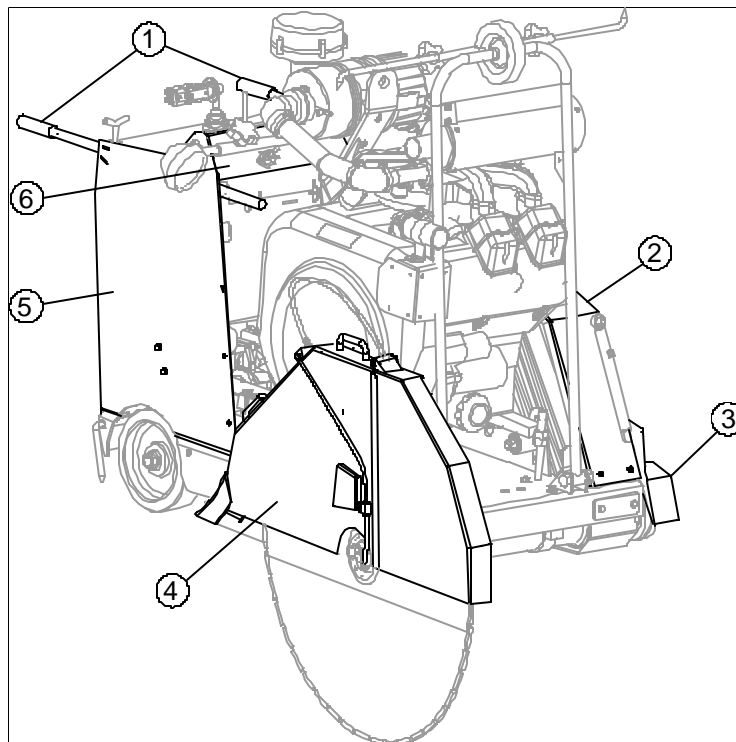

**Fig. 23 — Guards & Panels**

# Belts and Pulleys

Belt	Qty	Part Number
Blade Shaft Drive Belt	2	Part # 520009
Jackshaft Belt	1	Part # 521012
Transaxle Drive Belt	1	Part# 521004
Water Pump Option Belts	1	Part# 521006 Part# 521008

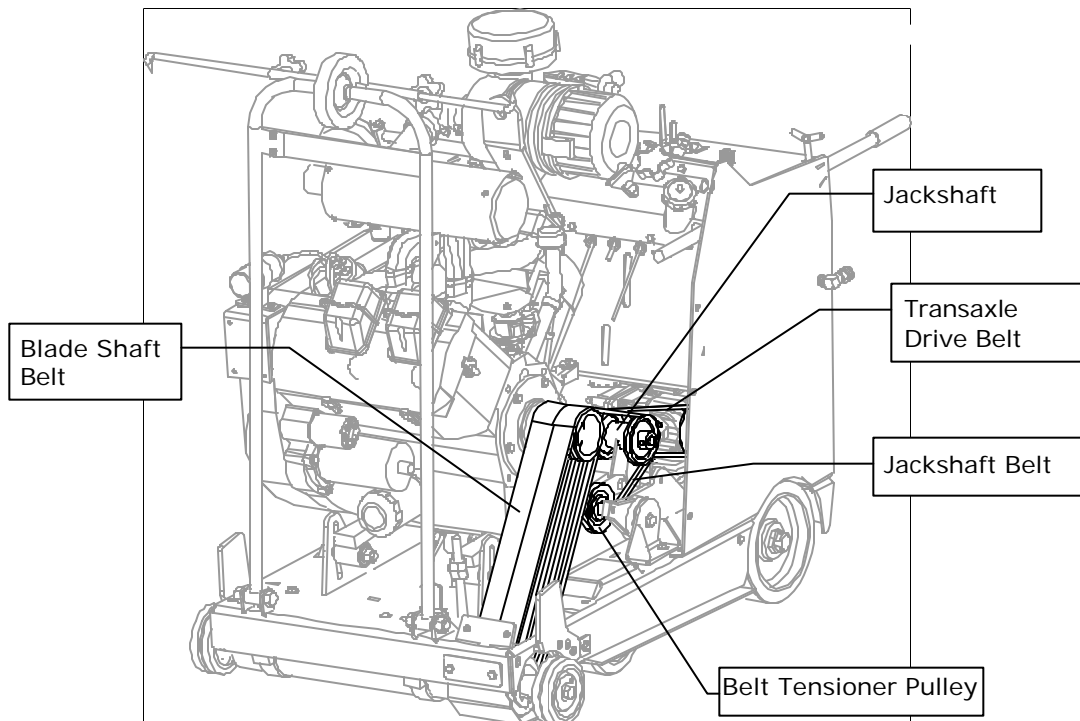

**Fig. 24 — Belt Locations**

## V-Belt Tension

Ideal V-Belt tension is the lowest tension at which the belt will not slip under peak load conditions. Check V-Belt tension frequently during the first 24-48 hours of run-in operation.

 <p><b>CAUTION</b></p>	<ul style="list-style-type: none"> <li>▪ Over-tensioning shortens belt and bearing life.</li> <li>▪ Keep belts clean of foreign material that may cause slippage.</li> <li>▪ Make V-Belt inspection a periodic procedure.</li> <li>▪ Never dress belts, as this can cause premature failure.</li> </ul>
---	---

## Adjusting Blade Shaft Drive Belt Tension



### NOTE

When tightening or loosening drive belts, raise the saw to reduce stress on the tensioning system, and gravity will assist you by pulling the engine backwards slightly.

1. Access the Panel on the side of the saw, loosen the Engine Mount Lock Bolts to allow the engine to rotate forward.
  - ◆ Requires 15/16" socket, 10" - 12" extension and ratchet or breaker bar.

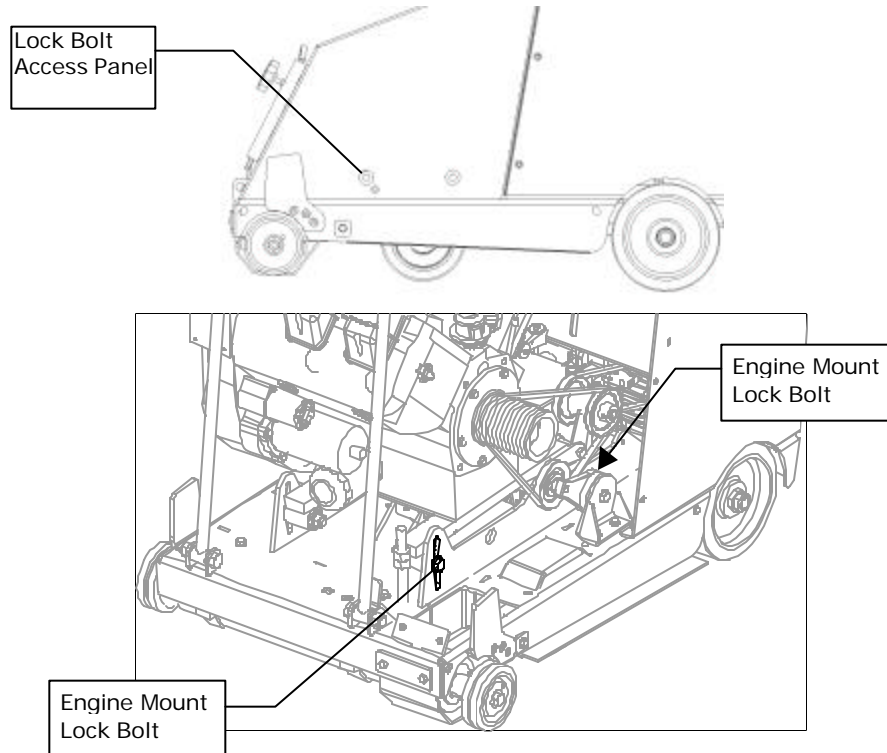

**Fig. 25 — Engine Mount Lock Bolts**

2. Loosen the jam nut on the Single Point Belt Tension Bolt.

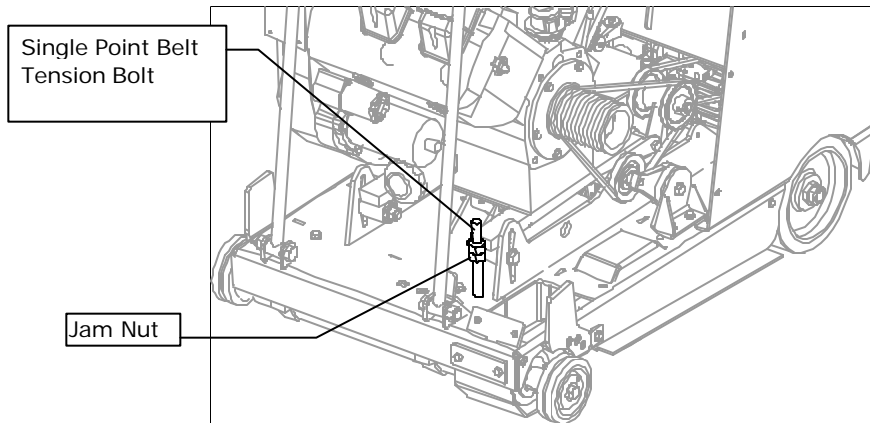

**Fig. 26— Single Point Belt Tension Bolt**

3. Adjust drive belt to the desired tension. *DO NOT* over tighten.
4. Tighten the Engine Mount Lock Bolt.
5. Turn the Single Point Tension Bolt until the head of the bolt no longer touches the frame. Tighten the jam nut to prevent the bolt from turning.

## **Replacing the Blade Shaft Belt:**

See **Fig. 25 & 26**, above...

1. Remove the lower belt guard from around the Blade Shaft sheave.
2. Loosen the engine mount lock bolts.
3. Loosen the single-point belt-tensioning bolt to allow the engine to roll forward.
4. Slide the belt off of the engine sheave and pull the belt down around the Blade Shaft sheave.
5. Slide the belt off the top of the Blade Shaft sheave.
6. Reverse the order to install a new belt.

## **Replacing the Jackshaft Belt**

See **Fig. 27** ...

1. Remove the Belt Guard.
2. Loosen the Rotary Tensioner Pulley.
3. Replace the Jackshaft Belt.
4. Adjust the Rotary Tensioner.

## Rotary Belt Tensioner

The Rotary Belt Tensioner system uses a 3/4"-headed bolt and a 15/16" or 1" nut to set belt tension by positioning an arm between the Tensioner Pulley and the Tensioner Base. Ridges on the Base mark the amount of tension.

1. Loosen the Bolt Head.
2. Rotate the Tensioner Nut clockwise until the desired belt tension is achieved.
3. Tighten the Bolt Head.
4. DO NOT OVER-TIGHTEN.

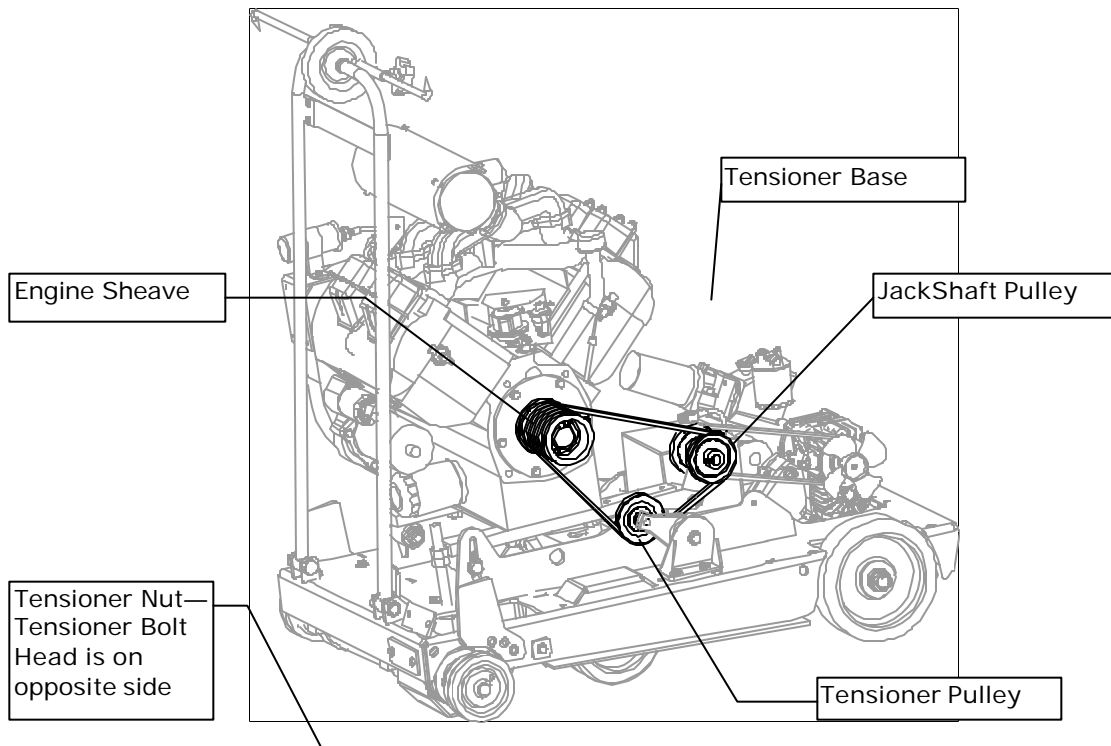

**Fig. 27 — The JackShaft Belt and Rotary Belt Tensioner System**

## **Blade Shaft Maintenance**

The fully enclosed Blade Shaft eliminates most maintenance. However, should the Blade Shaft need service or repair, contact Multiquip for details.

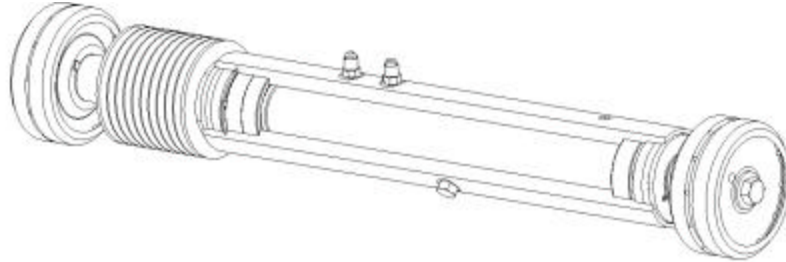

**Fig. 28 — Blade Shaft**

## **Blade Shaft Replacement**

To assure correct Blade Shaft/Wheel alignment it is recommended that this operation be performed by a Multiquip Authorized Service Center.

# Blade Collar Removal/Installation

Correct removal or installation of the Inner Blade Collar or Flange requires the Collar Puller (option Part Number 18503) shown in Figure 31.

 <b>WARNING</b>	Follow instructions closely to prevent injury from flying Blade Collars! Because of the tapered fit between Blade Collar and Blade Shaft, 5-10 tons of force is needed to release the inner collar. Parts and tools can become dangerous projectiles if instructions are not followed properly.
---	---

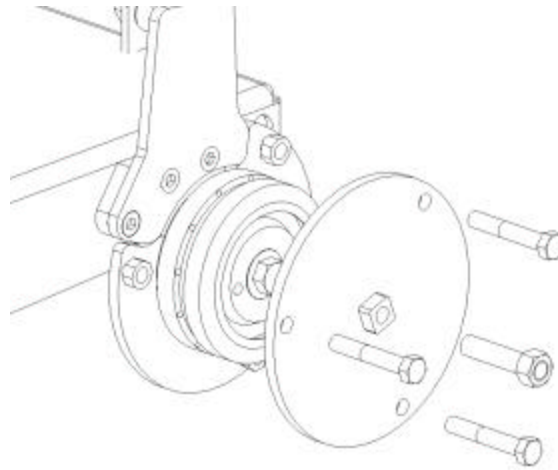

Fig. 29 — Using the Collar Puller

## Removing the Inner Blade Collar

With the Outer Blade Collar in place, and the Blade Mounting Bolt loosened approximately  $\frac{1}{4}$ ":

1. While the three perimeter bolts hold the two Puller Plates together, slide the Horseshoe Plate of the Collar Puller behind the (Shaft) side of the Inner Collar as shown above.
2. Tighten the center Puller bolt to remove the Inner Collar from the Blade Shaft.
  - ◆ *Having the Outer Collar in place prevents the Puller and Inner Collar from flying off when the taper breaks loose, and causing injury!*
  - ◆ *If the Inner Collar does not readily come free from the tapered Blade Shaft, lightly tap on the central Puller bolt. This should cause the collar to break free from the shaft.*

## Installing the Inner Blade Collar

1. Ensure that the tapered portion of the Blade Shaft, and the Inner Blade Collar are perfectly clean and free of burrs or indentations. Clean and repair as necessary
2. Ensure that the Drive Key is in place.
3. Slide the Inner Collar onto the tapered portion of the Blade Shaft
  - ◆ DO NOT use any lubricant! Lubricant prevents the tapered surfaces of the Collar and Shaft from mating properly.
4. Install the Outer Blade Collar, Collar Bushing, and Mounting Bolt.
  - ◆ Tighten with a ½” impact wrench to seat the tapered surfaces of the Inner Collar and Blade Shaft.

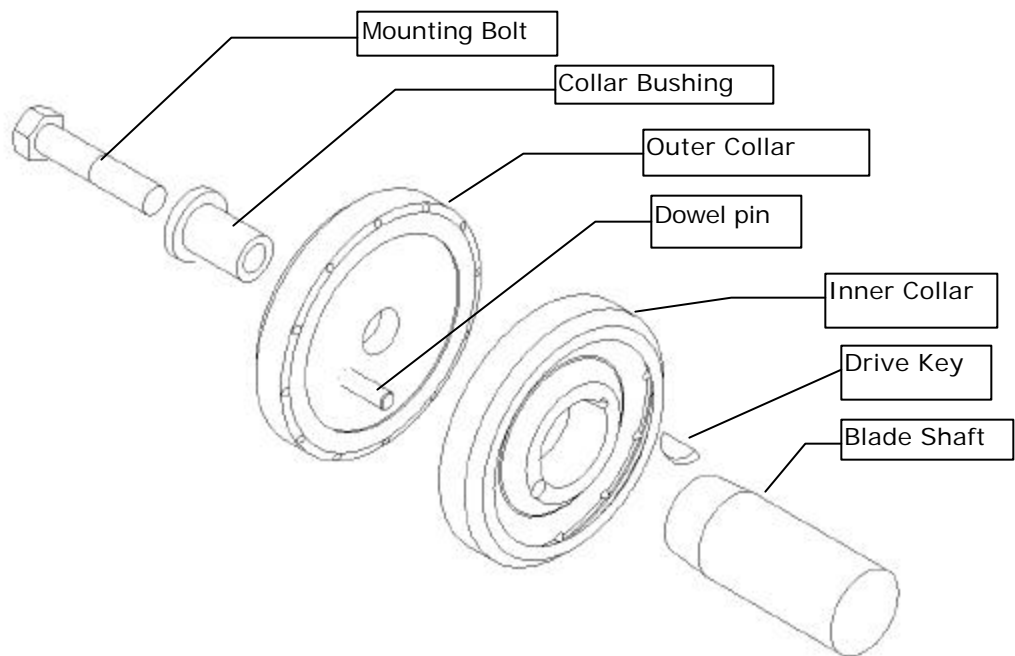

Fig. 30 — Installing the Inner Blade Collar



5. Loosen the Mounting Bolt and remove the Outer Collar and Bushing.
6. Inspect the Inner Collar to ensure the proper seating of the tapered fit.
  - ◆ The Inner Collar should be seated between .030" and 0.0" (flush) to the end of the Blade Shaft.

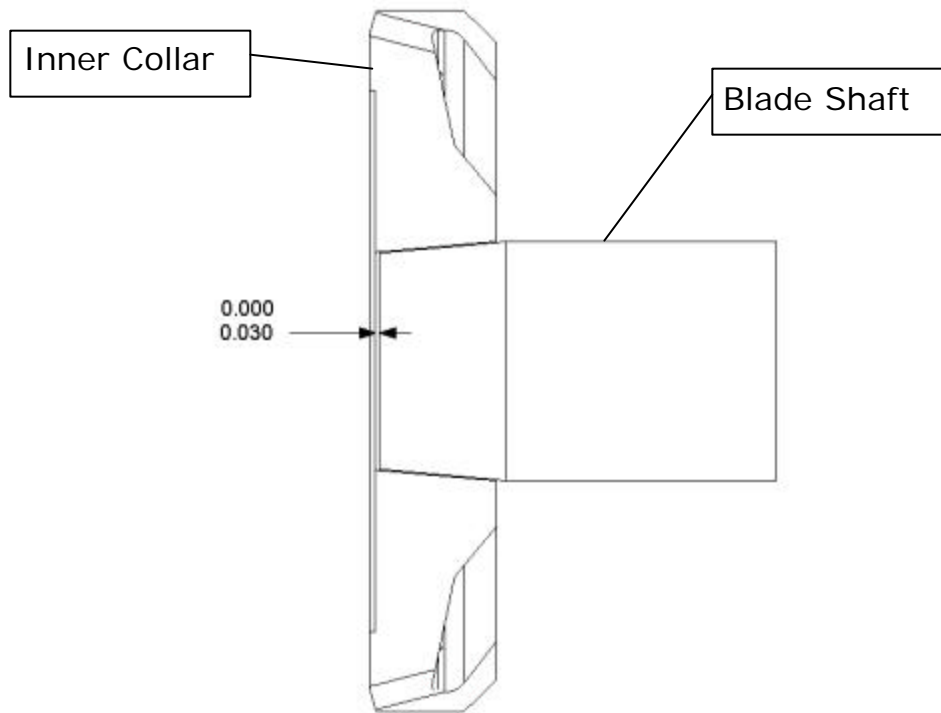

Fig. 31 — Proper seating of the Inner Collar on the Blade Shaft

7. Test to ensure that the Inner Collar does not wobble when rotated. Use an indicator dial on the face of the Collar. **Maximum tolerance is .003" run out on the face of the Collar.**

## Circuit Breakers

Three thermal circuit breakers are located inside the top of the Console.

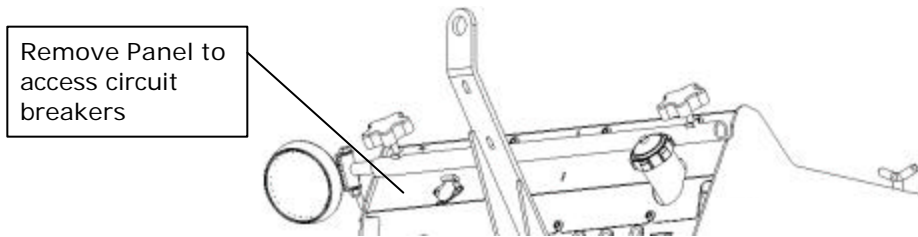

Fig. 32 — Circuit Breaker location

Under normal circumstances circuit breakers do not require service; they are automatically re-set when an overload condition is corrected. If a breaker is cycling on/off, locate the cause of the electrical overload and repair as required.

## Maximum Cut Depth Adjustment

This saw comes factory-adjusted for maximum usable cut depth. However, should you desire to change this setting:

1. Park the blade-less saw on a flat and level surface.
2. Fully lower the saw onto the Stop Bolts (see Fig. 33).
3. Measure the distance from the Blade Collars to the surface.
4. Adjust the Stop Bolts in or out until the Blade Collars have 1/8" to 3/16" ground clearance.
5. Ensure that both bolts are adjusted to the same settings so the load is evenly distributed.

# Lubrication

This saw has five grease fittings on the front axle assembly.

- Front axle pivot bearings (F1 & F3)
- Hydraulic lift cylinder ends (F2, and far end of cylinder)
- Depth Stop Pivot Plate (F4)

These fittings are easily accessed by raising the saw half way up, and then lifting the rear of the saw until the blade collars rest on the ground.

 <b>WARNING</b>	To prevent the possibility of crush injury, ensure that the saw is <i>securely</i> placed on blocks before servicing the lubrication points.
---	--

 <b>CAUTION</b>	Grease fittings every 50 hours of operation with a premium grade waterproof E. P. (extreme pressure) grease.
---	--

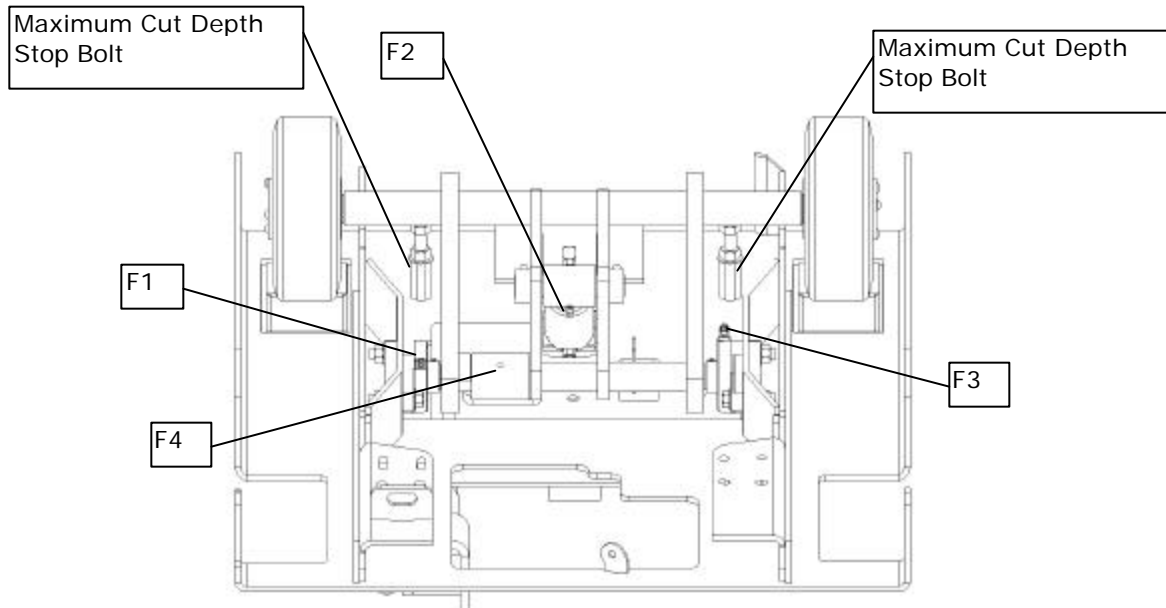

**Fig. 33 — Grease Fittings and Maximum Cut Depth Stops (view from back of saw)**

# Engine

The Model SP-6065 features a xx HP xx gasoline engine. See the engine manual for service details and oil recommendations.

- Check air filters daily, replace as required.
- Check engine oil level daily.
  - ◆ Level the frame prior to service to get an accurate reading.
  - ◆ **Do Not** over-fill with oil.
- Change engine oil and filter every 50 hours of operation

 <b>CAUTION</b>	Safety Air Filters are <b>not</b> intended to be used for primary air filtration. When the Primary Filter gets clogged, replace it immediately — <b>do not run saw using just the Safety filter.</b>
---	--

## Air and Oil Filter Chart

Filter	Qty	Part Number
Primary Air Filter	1	300004-1 (Donaldson #P827653)
Safety Air Filter	1	300004-2 (Donaldson #P829332)
Engine Oil Filter	1	306012 (Deutz # 1174416-SP)
Hydraulic System Filter	1	306002 (HydroGear # 51563)
Fuel Filter	1	304010 (Donaldson # 1174696)

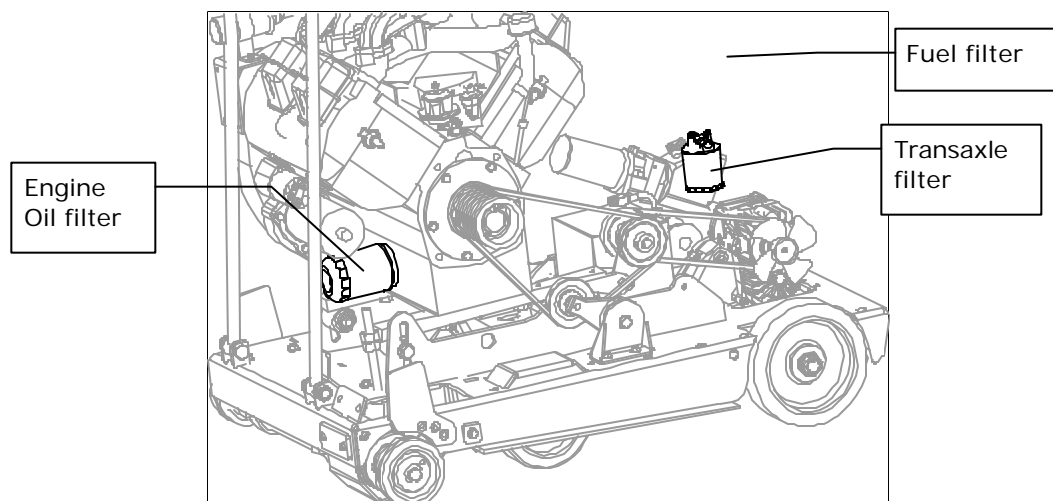
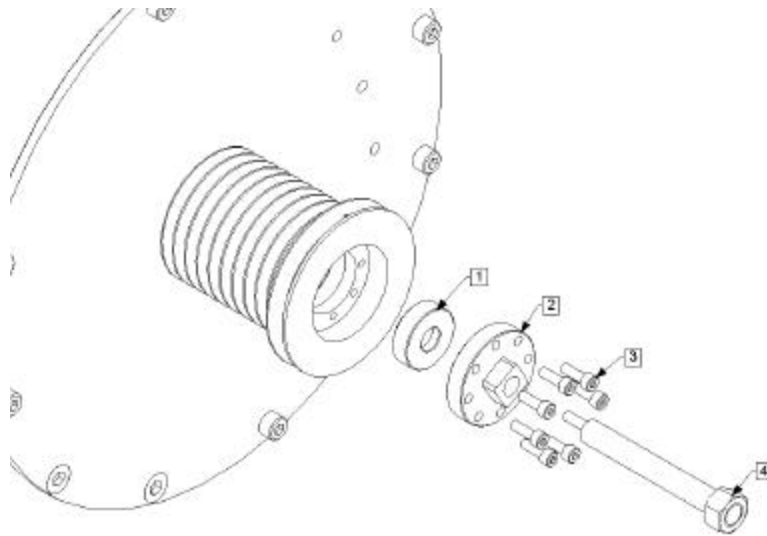

**Fig. 34 — Filters**

## PTO Drive Maintenance

Disassembly of the PTO Drive and replacement of the PTO Drive Sheave/Bearing Assembly requires the PTO Bearing Puller (P/N 18610). The Sheave/Bearing Assembly is not serviceable and must be replaced as a complete unit.

1. Remove the Drive Belt (see Replacing the Blade Shaft Drive Belt).
2. Remove the Drive Plate Assembly from the engine.
  - ◆ The Assembly is held on by 11 bolts.
  - ◆ Note the clocking orientation of the plate.
3. On the workbench:
  - ◆ Remove the Cap Screws and End Cap (Items 1 & 2, **Fig. 35**).
  - ◆ Remove the Splined Drive Cap Screws and the Drive Cap (Items 3 & 4, **Fig. 35**).
  - ◆ With a sharp pointed awl or similar tool, remove the flat wound spiral retaining ring (Item #5, **Fig. 35**)
  - ◆ Attach the PTO Bearing Puller in place of the Splined Drive Cap, as shown in **Fig. 35**.
  - ◆ Insert the Puller Alignment Bushing (1).
  - ◆ Attach the Puller Cap (2) with the Drive Cap Screws (3).
  - ◆ Thread in the PTO Bearing Puller Bolt (4).



**Fig. 35 — Attaching the PTO Bearing Puller to the Drive Plate Assembly**

- ◆ Tighten the Puller Bolt (4), to pull the Sheave/Bearing Assembly off of the Bearing Support (**Fig. 36**, #9).



# Replacing the Battery

This saw uses a Group 75, 12-Volt, 1000 cold cranking amp battery. To replace the battery:

1. Remove Engine Guard and Upper Belt Guard.
2. Loosen the Rotary Tensioner and remove the Transaxle Belt.
3. Loosen the two Engine Mount Lock Bolts and the Single Point Belt Tension Bolt.

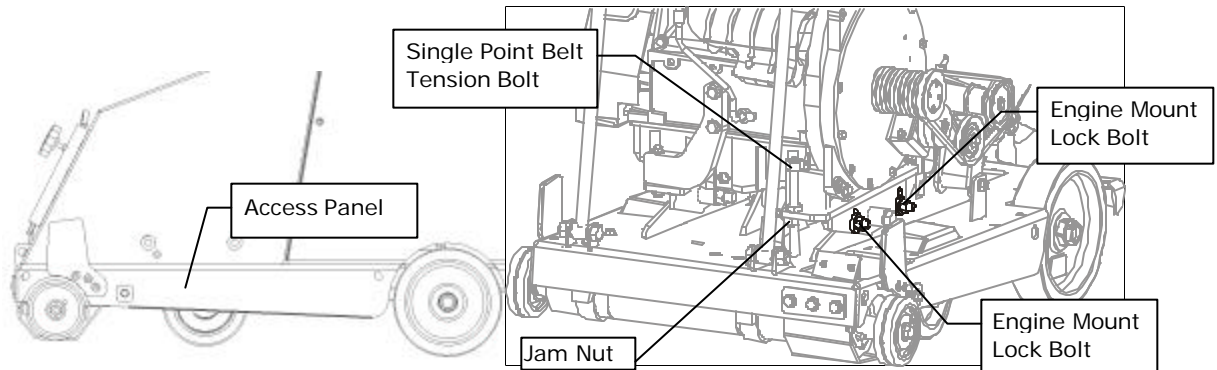

**Fig. 37 — Engine Mount Lock Bolts Single Point Belt Tension Bolt – from Belt Tension (similar to illustration)**

4. Tilt the saw down and roll the engine as far forward as possible, to create the maximum access opening. See figure 38.
5. Disconnect the battery cables, Positive first, to avoid arcing.
6. Remove the forward battery tie-down clip.
7. Carefully roll the battery up and maneuver it out through the space between the Control Console and the Engine.
8. To replace the battery, repeat steps 1-5 in reverse order

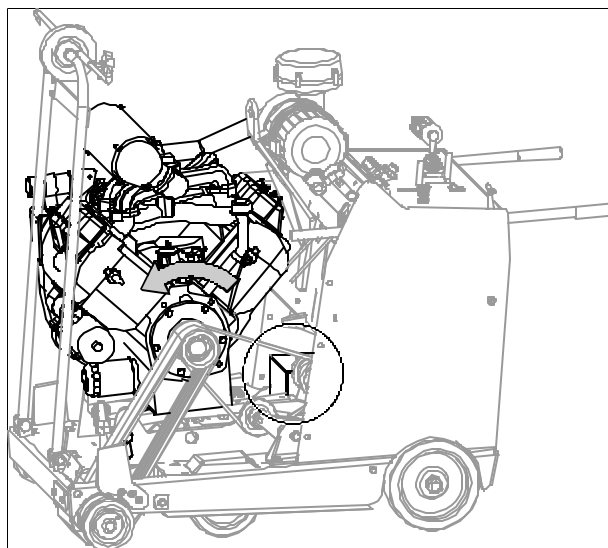

**Fig. 38 — Rotate Engine Forward to Remove the Battery**

## Raise-Lower System

This saw uses a 12-volt hydraulic pump and hydraulic cylinder to power the raise-lower system.

- ◆ Level frame prior to service to get an accurate reading.
- ◆ Check oil level daily.
- ◆ Fill the reservoir half to two-thirds full when cold
- ◆ Use 5W-30 premium grade engine oil.

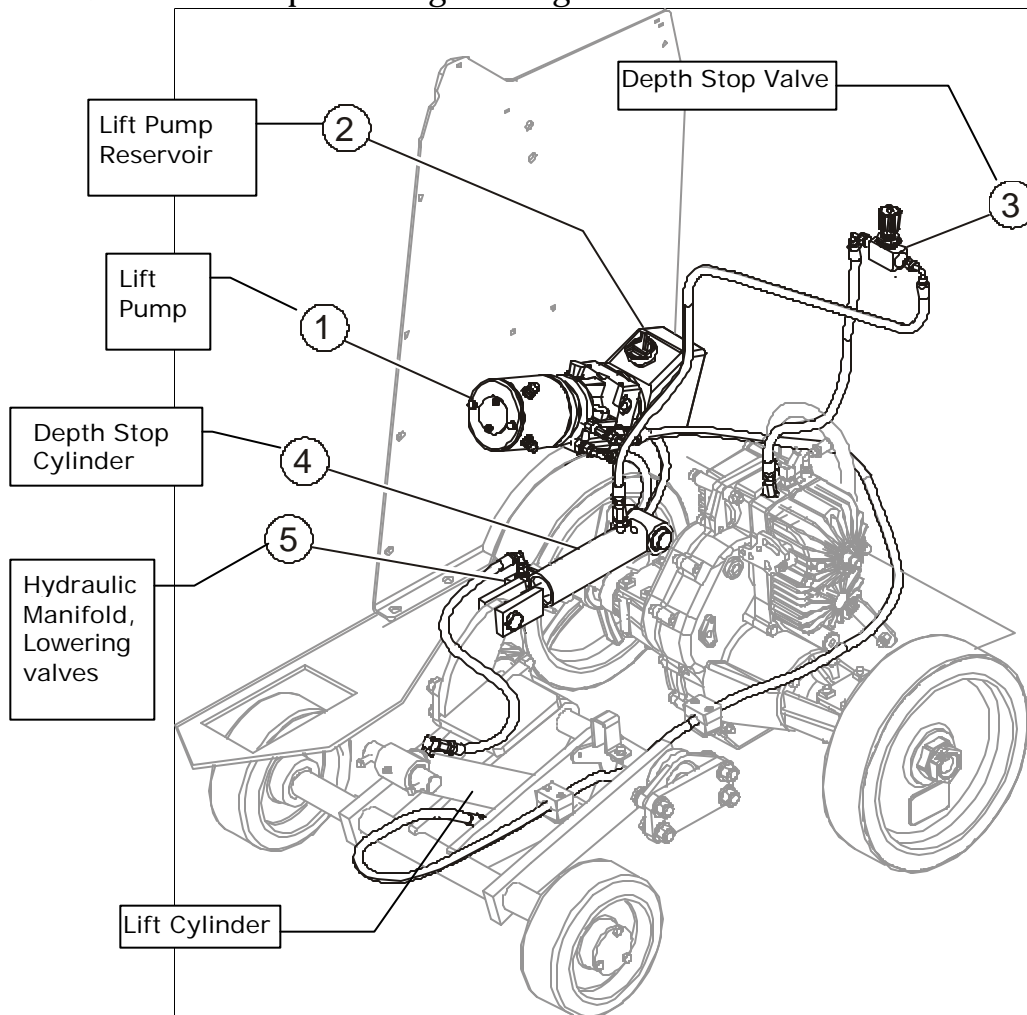

Fig. 39 — Raise-Lower System

### Raise/Lower Troubleshooting

If your new saw begins lowering all by itself when you release the Raise button, the problem may be caused by debris in the hydraulic line which is blocking the Lower valve in the open position.



# Joystick Tension Adjustment

The speed control joystick uses friction adjustment to provide the preferred “feel”:

1. Using a ¼” Allen wrench and 9/16” wrench, loosen both pivot bolts until they can be turned by hand. Pivot #1 only requires a 9/16” wrench, as the Allen nut side is welded in place.
2. Tighten pivot #1 until the handle is close to the desired “feel”.
3. Tighten pivot #2 until it just starts to increase the force required to move the handle.

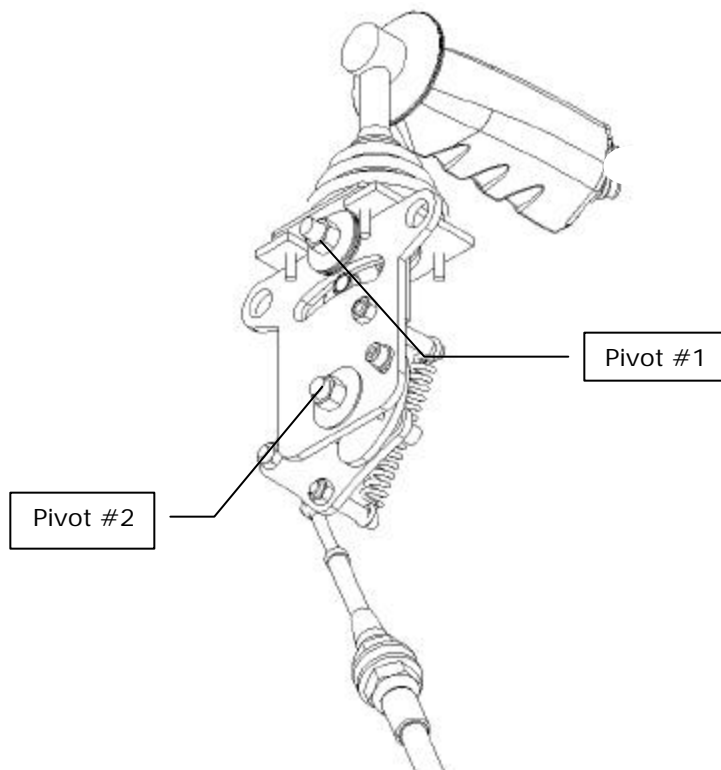

Fig. 40 — Joystick Adjustment

# Hydraulic System Maintenance

The hydraulic system consists of:

- Blade Shaft
- Transaxle
- Depth Stop Cylinder & Valve
- Lift Cylinder
- Hydraulic Pump
- Hydraulic Manifold
- Hydraulic Filter
- Oil Fill/ System Vent

## Routine Maintenance

- Check oil level daily.
  - ◆ *Level the saw frame* prior to service to get an accurate reading.
  - ◆ Fill reservoir to Fill line when cold, with 5W-30 premium grade engine oil.

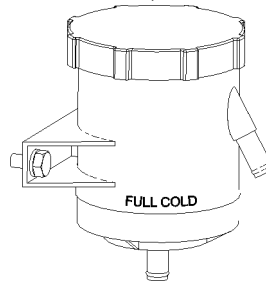

**Fig. 41 — Oil Reservoir Fill Line**

- Change oil and filter annually.

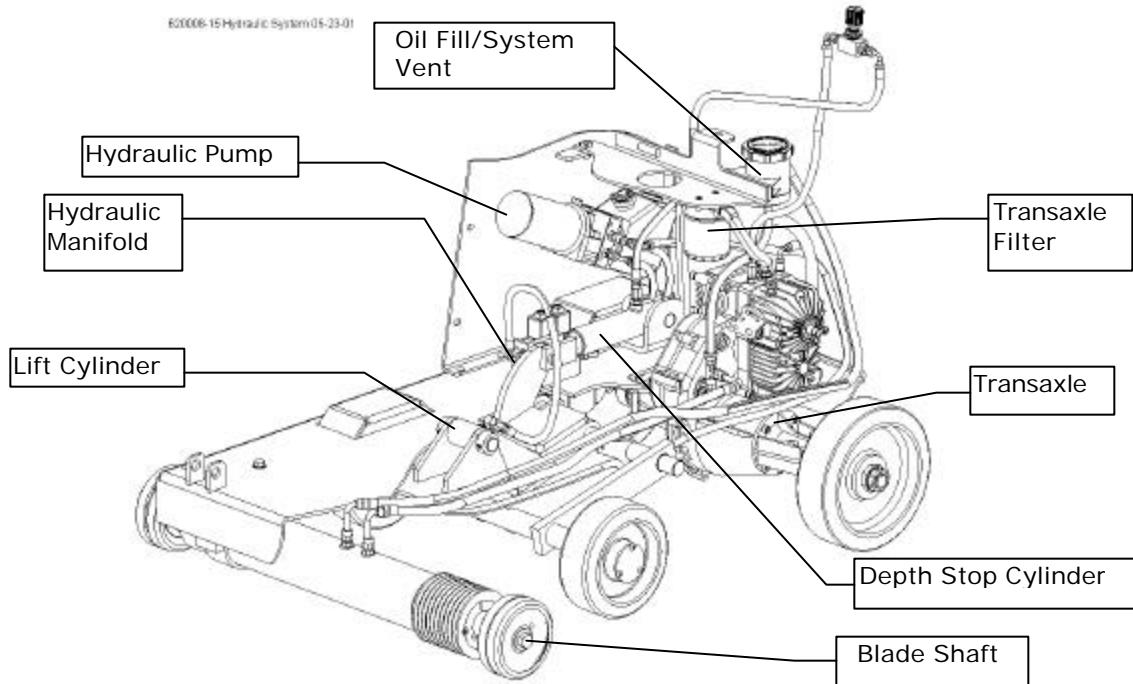
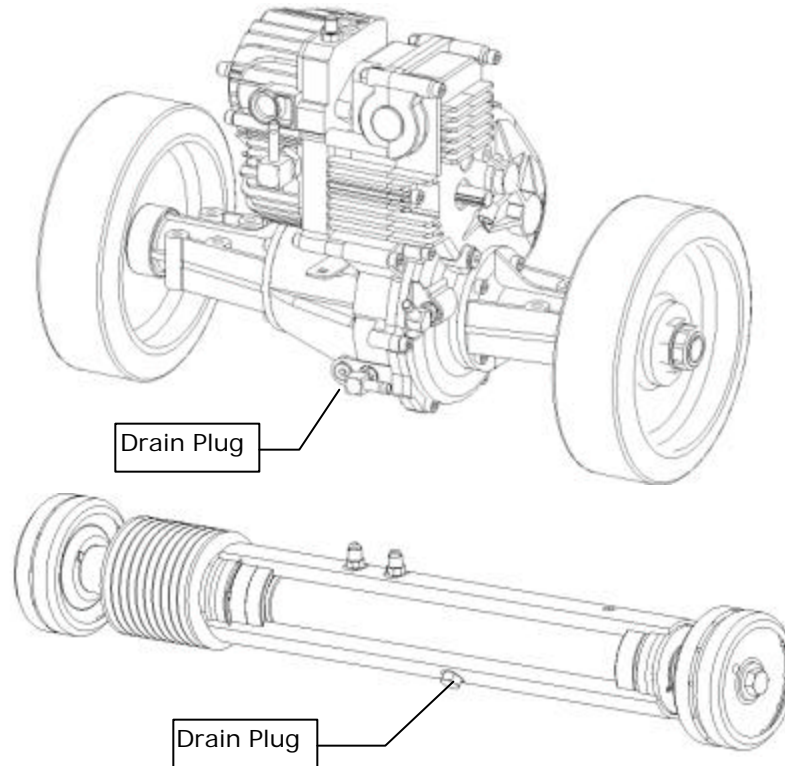

**Fig. 42 — The Hydraulic System**

## Draining & Filling the Hydraulic System

*To drain the hydraulic system:*

1. Remove the drain plug from the bottom of the Blade Shaft housing and the bottom of the Transaxle.



**Fig. 43 — Hydraulic System Drains**

2. Collect and dispose of the used oil in an environmentally friendly manner.
3. Remove the used oil filter. **See Fig. 42.**
4. Once drained, reinstall the drain plugs.
5. Pre-fill and install a new oil filter.

 <p><b>CAUTION</b></p>	<p>To prevent hydraulic pump damage, pre-fill the filter with oil prior to installing it.</p>
---	---

### *To fill the hydraulic system with oil:*

1. Add oil to the system reservoir.
  - The reservoir will need filling several times.
2. Run the engine for a couple minutes to cycle oil throughout the system.
  - Add more oil as required.
3. Repeat as necessary.

### *Tips*

- It takes 3-4 quarts to fill the hydraulic system when new, and somewhat less when changing the oil.
- Remove the oil reservoir cap to speed oil draining.
- When re-filling the system, raise the saw halfway up, and then lift the rear of the saw until the Blade Collars touch the ground. This will speed the filling process.
  1. After filling the system, jack the saw up so the drive wheels are off the ground. Start the saw, and move the joystick half way into FORWARD, to purge air out of the system.



#### **NOTE**

If the Blade Shaft is drained completely, it will require approximately 1 gallon to refill. If the transaxle is drained as well, it will require approximately one additional gallon.

## Bleeding the Depth Stop Cylinder

After changing the hydraulic system oil, or after disturbing the Depth Stop Cylinder plumbing, air may become trapped in the system and cause the Depth Stop Cylinder to work improperly. To remedy the situation, the Depth Stop Cylinder must be bled to remove trapped air. This procedure requires the use of the Depth Stop Block tool (P/N 584042)..

1. Open the Depth Stop Valve.
2. Fully raise the saw.
3. Place the Depth Stop Block between the Depth Stop Plate and the Front Axle.
4. Fully lower the saw.
- ◆ Verify that the Depth Stop Cylinder has fully collapsed.
5. With the Depth Stop Valve still open, and the engine running:
  - ◆ At the rear of the cylinder use a 1/8" diameter hose on the bleeder nipple. Use the length of hose to direct the flow of oil into a suitable receptacle.
  - ◆ Open the bleeder valve at the rear of the cylinder and allow the oil to flow until no air is detected in the fluid. Close the bleeder valve.
  - ◆ Dispose of the waste oil in an environmentally-friendly manner.
6. Remove the Depth Stop Block and test the operation of the Depth Stop.
7. Re-fill the Reservoir Fill bottle at the rear of the Fuel Tank.

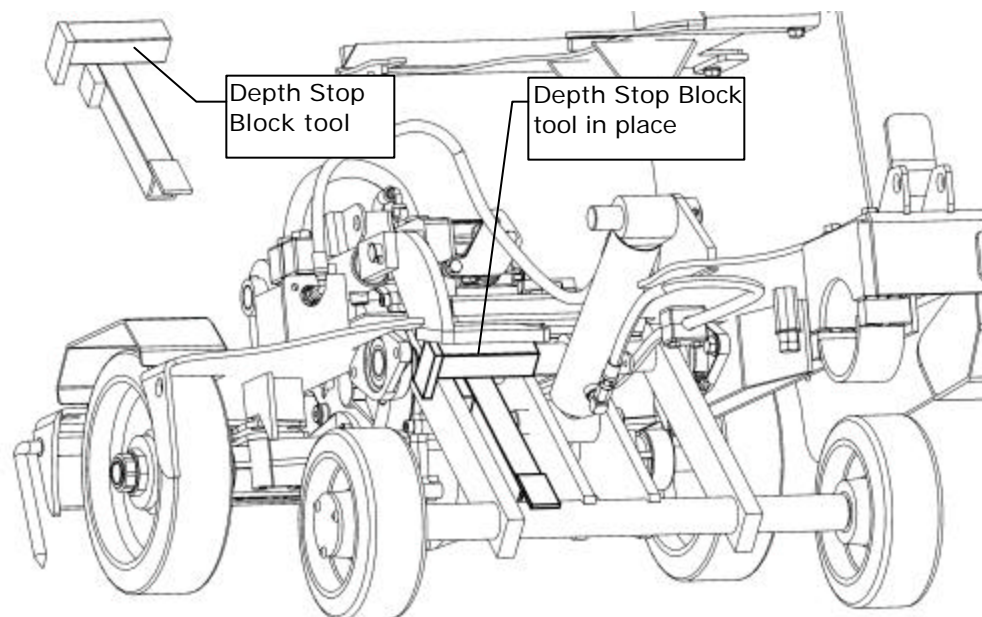

**Fig. 44 — Bleeding the Depth Stop Cylinder**

# Drive Wheel Alignment

Below is the technique recommended for aligning the wheels. Distance X is the same on both sides; the Front Wheel and Blade shaft axles must be at right angles to the frame edge. Distance A is 3/16" (.187") longer on the right side, so that the saw steers slightly left. Users may wish to alter the alignment to fit a particular application.

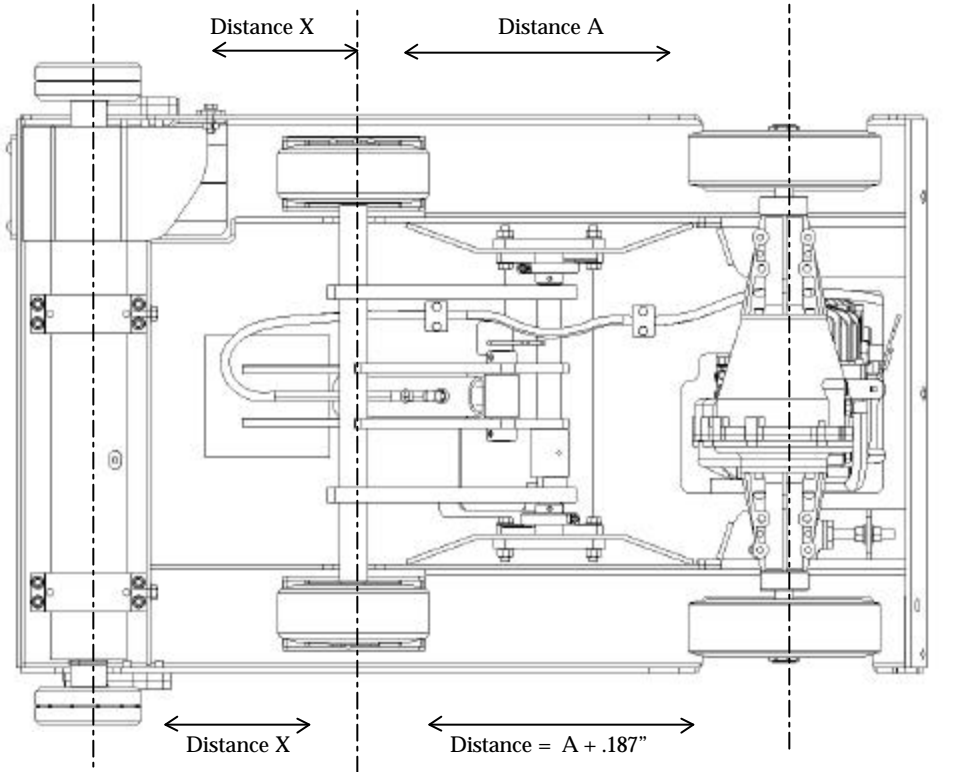
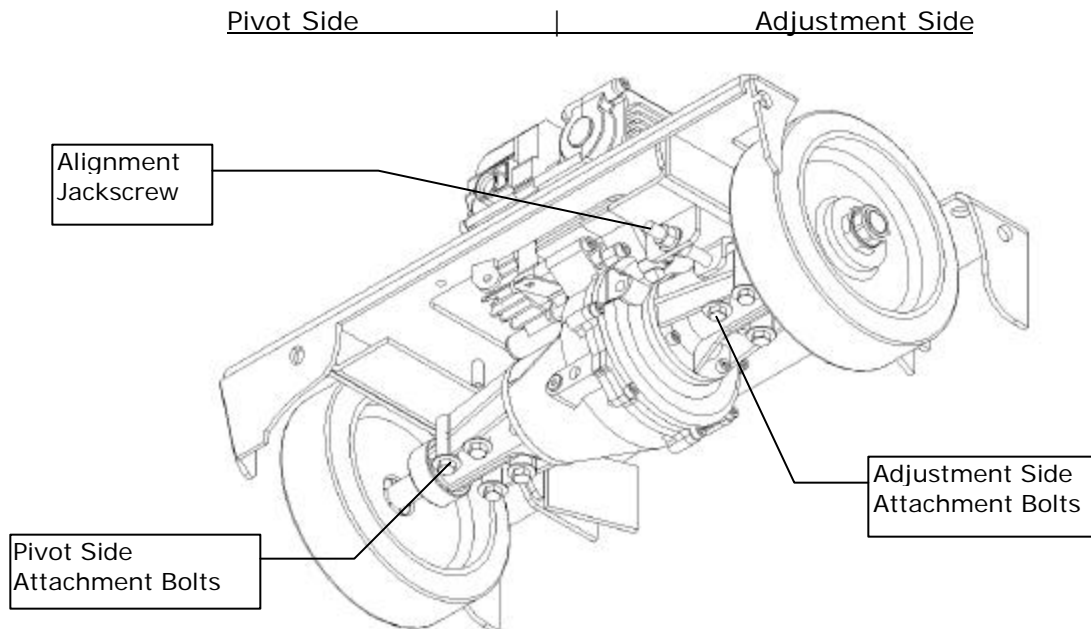

Fig. 45 — Drive Wheel Alignment

The drive wheels are aligned by adjusting the entire rear drive assembly:

1. Loosen the Transaxle Attachment Bolts just enough to move the Transaxle — do not completely loosen the bolts.
2. Loosen and tighten the Alignment Jackscrew nuts to move the Transaxle — and thus the wheels — in the appropriate direction to achieve the desired alignment distance (see Fig.44).
3. Lock down the Transaxle Attachment Bolts when the appropriate alignment distance is set.



**Fig. 46 — Drive Wheel Alignment Bolt Locations**

# SPECIFICATIONS

Engine	57 HP Turbocharged Deutz Diesel, direct injection, air/oil cooling, oil filter and above-frame remote oil drain.
Engine Air Cleaner	4-Stage air filtration, pre-cleaner plus cartridge element and safety element.
Fuel Tank	10 Gallon clear-molded plastic fuel tank with sight gauge, central drain and shutoff valve.
Blade Shaft Assembly	Fully enclosed bearings and shaft, oil bath lubrication, 2-3/8" diameter shaft, magnetic drain plug, seal protectors and protected remote oil fill and vent.
Blade Collars	Plated quick-disconnect, taper lock attachment, 5.5" diam., 24 water spray ports.
Blade Flushing	Minimum water usage system, evenly distributed across the blade, panel-mounted flow control.
Blade Range	14" to 36".
Max Cut Depth	15".
Blade Guard	Extra heavy design, slip-on type with double lip seal and quick disconnect water hose, two handles.
Blade Shaft Drive Belt	Dual 5--Groove 3VX530 Powerband.
Blade Control	12-Volt hydraulic raise/lower system, 3 blade plunge speeds, fast and slow blade plunge speed buttons on joystick, raise button on joystick, one-hand control.
Blade Depth Stop	Positive, heavy-duty hydraulically controlled depth stop.
Balance	Front steer.
Handlebars	3-Position adjustable angle, storage position, quick locks.
Front Wheels	8" x 3", precision sealed bearings in each wheel with extra end seals and seal protectors, no grease points.
Rear Wheels	12" x 3".
Drive System	Hydrostatic powered transaxle with infinite speed control, joystick control, remote oil filter and up to 300 feet per minute travel speed. Locked axle drive.
Engine Controls	Twist-lock throttle, backlit tachometer with hour meter, voltmeter, oil pressure gauge and 3-position ignition switch.
Battery	12-Volt, group 75, 1000 cold cranking amps.
Front Pointer	Heavy gauge steel, 6" pointer wheel and plastic-coated tether.
Rear Pointer	Standard, adjustable.
Hardware	Grade 8 fasteners throughout.
Tools	15/16" Blade wrench.
Dimensions	L= 47-1/2" with handlebars stored, W = 32" w/o blade collars, H= 44" with front pointer up.
Weight	Approx. 1,500 Pounds, with oil but no fuel. (Actual weight depends on blade guard used.)
Serviceability	Spin-on oil filters, lubrication points, lube every 50 hours.



# Dimensions and Weights

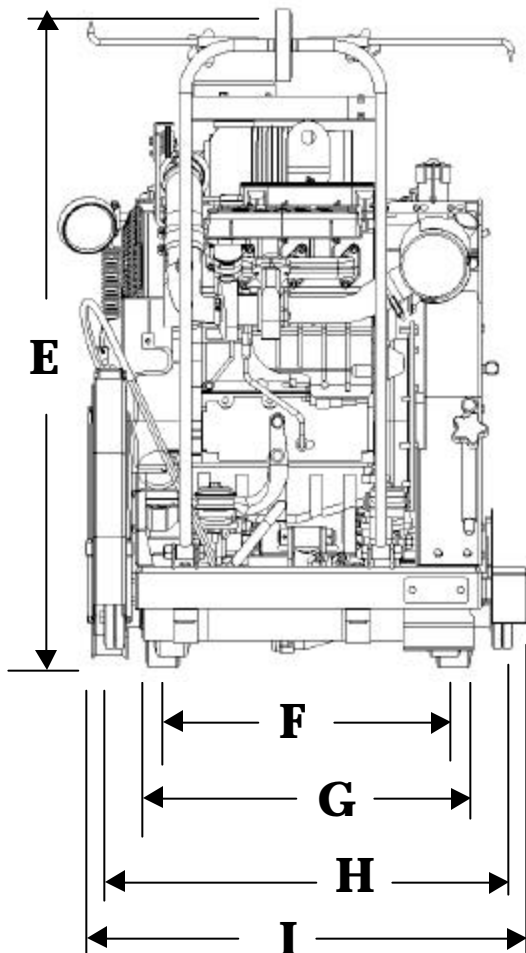
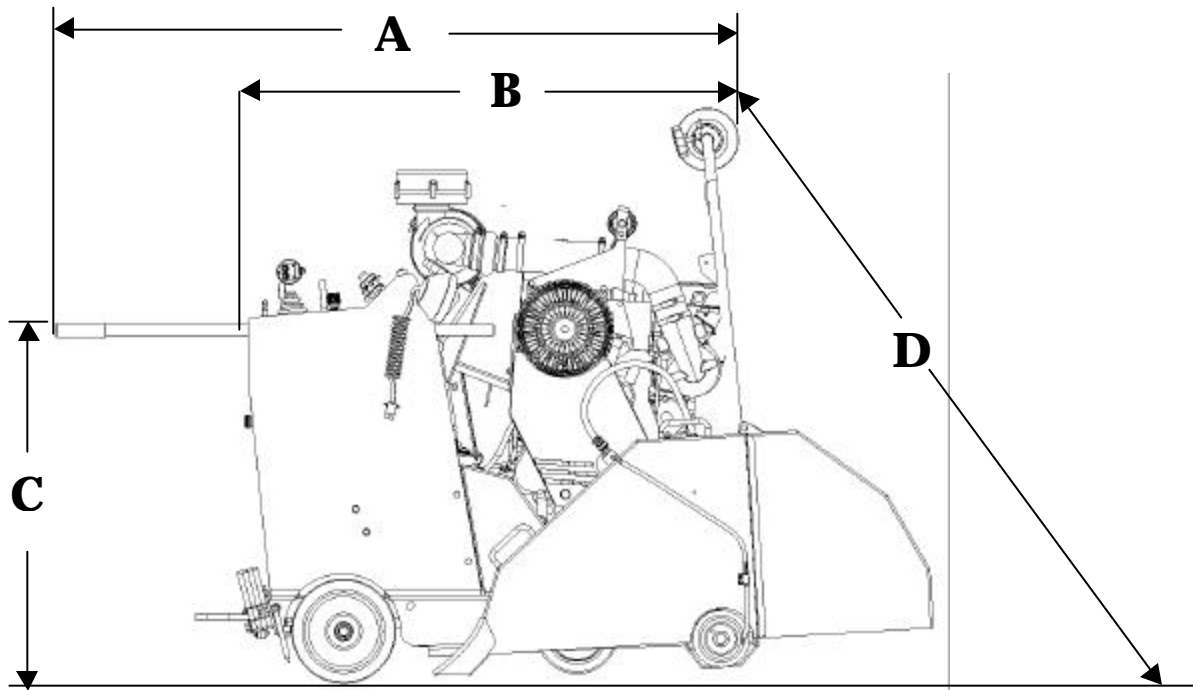

<b>A</b>	Max Length, Handle Bar Extended, Pointer Bar UP	<b>76.0"</b>
<b>B</b>	Max Length, Handle Bar Removed, Pointer Bar UP	<b>49.0"</b>
<b>C</b>	Max Height, Console Top to Surface	<b>36.0"</b>
<b>D</b>	Max Length, Handle Bar Extended, Pointer Bar DOWN	<b>125.0"</b>
<b>E</b>	Max Height	<b>55.0"</b>
<b>F</b>	Wheel Base, Front Wheels	<b>26.0"</b>
<b>G</b>	Wheel Base, Rear Wheels	<b>28.0"</b>
<b>H</b>	Max Width, Guards, Covers OFF	<b>35.0"</b>
<b>I</b>	Max Width, Guards, Covers ON	<b>38.0"</b>

<b>Crated Dimensions</b>	<b>60" x 60" x 61"</b>
<b>Crated Weight ( 1 Blade Guard )</b>	<b>1,600 lbs.</b>

<b>Uncrated Weight ( 1 Blade Guard )</b>	<b>1,500 lbs.</b>
--	-------------------



**MULTIQUIP INC.**  
POST OFFICE BOX 6254  
CARSON, CA 90749  
310-537-3700 • 800-421-1244  
FAX: 310-537-3927  
E-MAIL: [mq@multiquip.com](mailto:mq@multiquip.com)  
[www: multiquip.com](http://www.multiquip.com)

Atlanta • Boise • Dallas • Houston • Newark  
Quebec, Canada • Manchester, UK • Rio De Janeiro, BR •

---