



XPowEr Powerpack Solar 400

Owner's Guide

About Xantrex

Xantrex Technology Inc. is a world-leading supplier of advanced power electronics and controls with products from 50 watt mobile units to 2.5 MW utility-scale systems for wind, solar, batteries, fuel cells, microturbines, and backup power applications in both grid-connected and stand-alone systems. Xantrex products include inverters, battery chargers, programmable power supplies, and variable speed drives that convert, supply, control, clean, and distribute electrical power.

Trademarks

XPower Powerpack Solar 400 is a trademark of Xantrex International. Xantrex is a registered trademark of Xantrex International.

Other trademarks, registered trademarks, and product names are the property of their respective owners and are used herein for identification purposes only.

Notice of Copyright

XPower™ Powerpack Solar 400 Owner's Guide © March 2007 Xantrex International. All rights reserved.

Exclusion for Documentation

UNLESS SPECIFICALLY AGREED TO IN WRITING, XANTREX TECHNOLOGY INC. ("XANTREX")

- (a) MAKES NO WARRANTY AS TO THE ACCURACY, SUFFICIENCY OR SUITABILITY OF ANY TECHNICAL OR OTHER INFORMATION PROVIDED IN ITS MANUALS OR OTHER DOCUMENTATION.
- (b) ASSUMES NO RESPONSIBILITY OR LIABILITY FOR LOSSES, DAMAGES, COSTS OR EXPENSES, WHETHER SPECIAL, DIRECT, INDIRECT, CONSEQUENTIAL OR INCIDENTAL, WHICH MIGHT ARISE OUT OF THE USE OF SUCH INFORMATION. THE USE OF ANY SUCH INFORMATION WILL BE ENTIRELY AT THE USER'S RISK; AND
- (c) REMINDS YOU THAT IF THIS MANUAL IS IN ANY LANGUAGE OTHER THAN ENGLISH, ALTHOUGH STEPS HAVE BEEN TAKEN TO MAINTAIN THE ACCURACY OF THE TRANSLATION, THE ACCURACY CANNOT BE GUARANTEED. APPROVED XANTREX CONTENT IS CONTAINED WITH THE ENGLISH LANGUAGE VERSION WHICH IS POSTED AT WWW.XANTREX.COM.

Date and Revision

March 2007 Revision B

Part Number

975-0328-01-01

Product Number

852-2071

Contact Information

Telephone: 1-888-291-3544 (Xantrex toll free)

About This Guide

Purpose

The purpose of this Owner's Guide is to provide explanations and procedures for installing, operating, maintaining, and troubleshooting the XPower Powerpack Solar 400.

Conventions Used

The following conventions are used in this guide.



WARNING

Warnings identify conditions that could result in personal injury or loss of life.



CAUTION

Cautions identify conditions or practices that could result in damage to the product or to other equipment.

Important: These notes describe an important action item or an item that you must pay attention to.

Related Information

You can find more information about Xantrex Technology Inc. as well as its products and services at **www.xantrex.com**.

Important Safety Instructions

The XPower Powerpack Solar 400 generates a type of AC power similar to a normal household wall outlet. Operating the Powerpack Solar 400 incorrectly or misusing it may damage the equipment or create hazardous conditions for the user.

Important: Before using your XPower Powerpack Solar 400, be sure to read these safety instructions and the operational procedures in the manual. Retain this manual for future reference.

Warnings and Cautions



WARNING: Limitations on Use

The XPower Powerpack Solar 400 is not intended for use in connection with life support systems or other medical equipment or devices.



WARNING: Shock hazard. Keep away from children.

The Powerpack Solar 400 generates the same potentially lethal AC power as a normal household wall outlet. Do not insert foreign objects into the AC sockets, the DC input/output power socket (DC socket), USB port, speaker grills, or the ventilation holes. Do not expose this product to water, rain, snow, or spray.

Do not open or disassemble the Powerpack Solar 400.



WARNING: Explosion hazard

Do not use this product where there are flammable fumes or gases, such as in the bilge of a gasoline- powered boat, or near propane tanks. Do not use this product in an enclosure containing automotive-type lead acid batteries. These batteries, unlike the sealed AGM battery in Powerpack Solar 400, vent explosive hydrogen gas which can be ignited by sparks caused when making electrical connections.

When working on electrical equipment, always ensure someone is nearby to help you in an emergency.



WARNING: Heated surface

Ensure at least 2" (5 cm) air space is maintained on all sides of the Powerpack Solar 400. During operation, keep away from materials that may be affected by high temperatures such as blankets, pillows and sleeping bags.



CAUTION

Do not connect any AC appliance with the neutral conductor connected to ground to the Powerpack Solar 400 including AC residential electrical distribution panels.



CAUTION

Do not expose the Powerpack Solar 400 to temperatures over 104 °F (40 °C).

Precautions for Using Rechargeable Appliances



CAUTION

The output of the inverter is non-sinusoidal.

Most rechargeable battery-operated equipment uses a separate charger or transformer that is plugged into an AC receptacle and produces a low voltage charging output.

Some chargers for rechargeable batteries can be damaged if connected to the XPower Powerpack Solar 400.

Do not use the following with the XPower Powerpack Solar 400:

- Small battery-operated appliances like flashlights, razors, and night lights that can be plugged directly into an AC receptacle to recharge.
 - Some chargers for battery packs used in hand power tools. These affected chargers display a warning label stating that dangerous voltages are present at the battery terminals.
-

Important: If you are unsure about using your rechargeable appliance with the Powerpack Solar 400, contact the equipment manufacturer to determine the rechargeable appliance's compatibility with the modified sine wave (non-sinusoidal) AC waveform.

First Aid

The internal battery is a sealed, lead-acid type battery. It is not designed to be user replaceable. However, if a leak is detected, stop operating and handling the Powerpack Solar 400 immediately.

IF BATTERY ACID CONTACTS EYES:

1. Immediately flush with cold running water for at least 15 minutes.
2. Then seek prompt medical attention.

IF BATTERY ACID CONTACTS SKIN:

1. Wash thoroughly with soap and water.
2. If skin irritation persists, obtain medical attention immediately.

Note: Baking soda neutralizes lead-acid battery electrolyte.

Contents

Important Safety Instructions----- iii

Warnings and Cautions ----- iii

Precautions for Using Rechargeable Appliances ----- v

First Aid ----- vi

1 Introduction

About the Powerpack Solar 400 ----- 1

Comprehensive Protection ----- 1

 Automatic Overload ----- 1

 Overheating ----- 2

 Low Battery Protection ----- 2

2 Features

Contents ----- 3

Powerpack Solar 400 Features ----- 4

 Front and Side Panels ----- 4

 Control Panel and Display ----- 5

 Power Socket Side Panel ----- 6

 Solar Panel Components ----- 7

 Backside Panel ----- 8

 Accessories ----- 8

3 Operation

Operating Conditions and Guidelines ----- 9

Choosing a Location ----- 10

Recharging the Powerpack Solar 400 Battery ----- 11

 Charging with the AC Charger ----- 12

 Powerpack Solar 400 AC Charging Feature----- 12

Charging with the DC-to-DC Accessory Cable - - - - -	14
Recharging with a Generator's Regulated 12 Vdc Outlet- - -	16
Recharging From the Solar Panel - - - - -	17
Interpreting Display Codes - - - - -	19
Checking Battery and AC Status - - - - -	19
AC Appliances- - - - -	22
Operating AC Appliances - - - - -	23
Low-Battery Alarm - - - - -	23
Overload Protection- - - - -	24
High Surge Appliances - - - - -	24
Trouble Appliances - - - - -	24
12 Vdc Appliances - - - - -	25
Operating DC Appliances - - - - -	26
Low-Battery Alarm - - - - -	26
Overload Protection- - - - -	26
USB Devices - - - - -	27
Charging Devices via the USB Port - - - - -	28
Low Battery Alarm - - - - -	28
Using the LED Lamps- - - - -	29
Low Battery Alarm - - - - -	29
Using the Back Stand - - - - -	30

4 Maintenance

Solar Panel Maintenance - - - - -	31
Battery Maintenance- - - - -	31
Battery Life - - - - -	32
Recycling - - - - -	32

5 Troubleshooting

Common Problems - - - - - 35
 Buzz in Audio Equipment - - - - - 35
 Television Interference - - - - - 35
Troubleshooting Reference - - - - - 36

A Specifications

Electrical Specifications - - - - - 41
Physical Specifications - - - - - 43

Warranty and Return Information - - - - - 45

Tables

Table 5-1 Troubleshooting reference ----- 36
Table 5-2 Display Error Codes ----- 39

Figures

Figure 2-1	Package Contents -----	3
Figure 2-2	Front and Side Panels -----	4
Figure 2-3	Control Panel and Display -----	5
Figure 2-4	Power Sockets -----	6
Figure 2-5	Solar Panel Component -----	7
Figure 2-6	Backside Panel -----	8
Figure 2-7	Accessories -----	8
Figure 3-1	Charging with AC Power -----	13
Figure 3-2	Charging with DC Power -----	15
Figure 3-3	Male/female Connectors -----	17
Figure 3-4	Charging with the Solar Panel -----	18
Figure 3-5	Different Display Codes -----	19
Figure 3-6	Operating AC Appliances -----	23
Figure 3-7	Operating DC Appliances -----	26
Figure 3-8	Charging USB Devices -----	28
Figure 3-9	LED Lamp Controls -----	29
Figure 3-10	Back Stand -----	30

1

Introduction

About the Powerpack Solar 400

Easy-to-use and designed for years of reliable service, the Powerpack Solar 400 is a portable power source designed to provide limited AC power in the event utility power is interrupted or is not available. It can run many AC appliances and 12-volt DC appliances and charge many USB-enabled devices via the USB charging port.

Powerpack Solar 400:

- Powers 115-volt AC appliances up to 320 W continuous power and 400 W peak power
- Powers 12-volt DC appliances
- Charges small devices via a USB port
- Provides lighting for emergency use
- Allows the detachable solar panel (supplied) to charge the internal battery
- Allows AC, DC, and USB appliances to be run on the unit for an extended period of time while the solar panel receives energy from sunlight

Comprehensive Protection

Automatic Overload

The Powerpack Solar 400 has built-in protection against output overload. If you connect an appliance that draws more than 400 W from the AC Socket(s), or one which draws excessive surge power up to 600 W, the power to the AC Sockets automatically shut off. The unit will reset automatically after the loads are removed and the unit cools down.

The DC Socket is protected by a thermal switch. If an overload condition ($> 144 \text{ W}$) occurs while using the DC Socket, the excessive temperature will cause the switch to open and shut down the power to the socket.

Overheating

The Powerpack Solar 400 is protected from overheating. If the inverter exceeds a safe temperature, power to the unit automatically shuts off. It will reset automatically after the unit cools down.

Low Battery Protection

Low battery protection protects the internal battery from excessive discharge and possible damage. An audible alarm alerts you when the internal battery is nearly discharged at 11.0 Vdc and the unit turns off at 10.5 Vdc .

2 Features

Chapter 2 describes the main features of the Powerpack Solar 400. We recommend that you familiarize yourself with these features before operating the unit.

Contents

Your Powerpack Solar 400 package includes the items shown in Figure 2-1.

If any of these materials are missing or are unsatisfactory in any way, please contact Customer Service, see “Warranty and Return Information” on page 45.

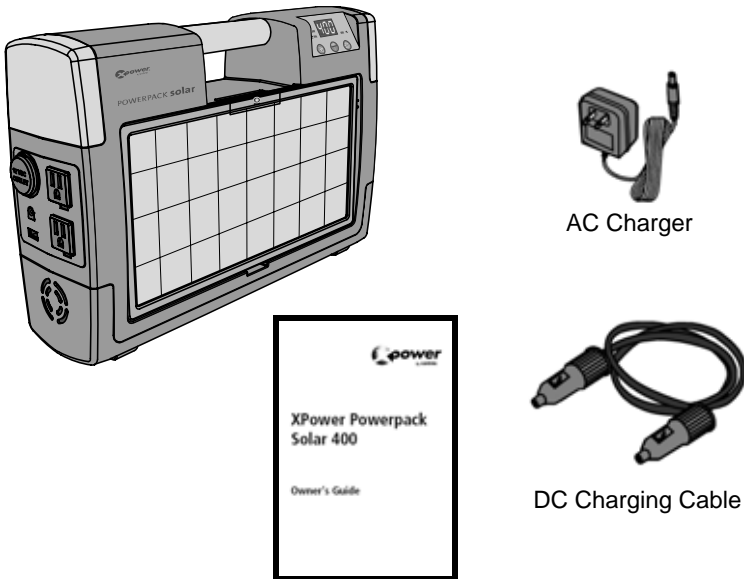

Figure 2-1 Package Contents

Powerpack Solar 400 Features

Front and Side Panels

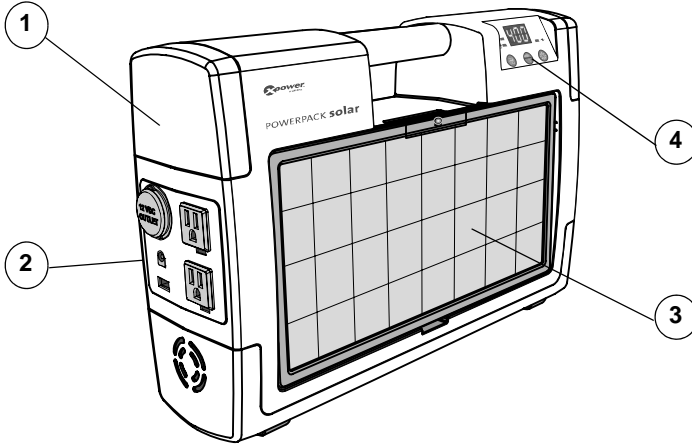

Figure 2-2 Front and Side Panels

Feature	Description
①	Hi-bright LED Lamp (located on each side) Provides ambient light to surrounding area. The button switch is located on the control panel.
②	Power Socket Side Panel Contains the DC and AC sockets, AC charging port, and USB port.
③	Solar Panel Component Contains the detachable solar panel and connectors.
④	Control Panel Contains the digital display and main controls for operating the Powerpack Solar 400.
Not shown	Audible Alarm (inside the unit) sounds in the event of an overload, over-temperature, or a low battery condition.

Control Panel and Display

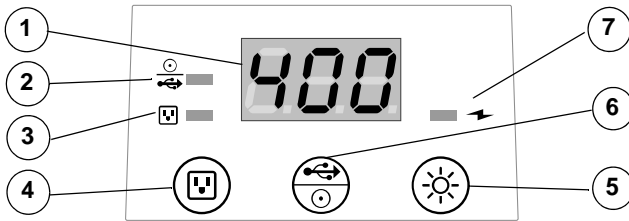

Figure 2-3 Control Panel and Display

Feature	Description
①	<p>The Digital Display flashes intermittently:</p> <ul style="list-style-type: none"> • -P-, then Output power in W (0 to 400) and • -[-, then Battery charge capacity status in % (40 to 100), or • -[-, then Battery charge capacity status as L0, if % is below 40 <p>for 30 seconds before turning off to conserve power.</p> <p>Note: The symbol EOx flashes when the unit alarms and encounters an error. “x” is a numeric error code. See Table 5-2, “Display Error Codes” on page 39.</p>
②	<p>DC/USB LED Indicator Light comes on when the DC socket and USB port are activated.</p>
③	<p>AC LED Indicator Light comes on when the AC sockets are activated.</p>
④	<p>Press and hold the AC Button for one second to activate the AC sockets. Press and hold again to turn power off.</p>
⑤	<p>Press and hold the Lamp Button for one second to turn the hi-bright lamps on. Press and hold again to turn power off.</p>
⑥	<p>Press and hold the DC/USB Button for one second to activate the DC socket and USB port. Press and hold again to turn power off.</p>
⑦	<p>The Charging Status indicator light blinks when charging using the AC Charger. The light stays on when the battery reaches its full charge.</p> <p>Note: Does not work with the DC socket and solar panel.</p>

Power Socket Side Panel

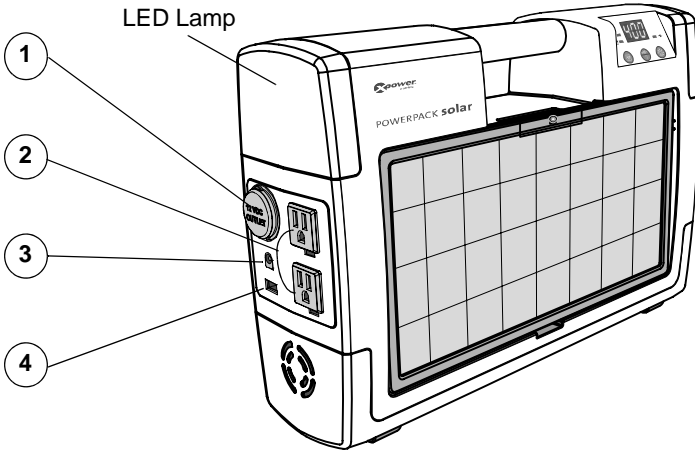

Figure 2-4 Power Sockets

Feature	Description
1	<p>DC Input/Output Power Socket (DC Socket):</p> <ul style="list-style-type: none"> Power 12-volt DC auto, RV, or marine appliances (output). Recharge Powerpack Solar 400 from a 12 V outlet in a vehicle using the DC Charging Cable (input). <p>Note: The DC socket is activated by pressing and holding the DC/USB button for one second on the control panel.</p>
2	<p>There are two AC Sockets which provide up to 320 W of continuous power and up to 400 W peak power to various household appliances. The two sockets accept standard North American three-prong electrical plugs.</p> <p>Note: The AC sockets are activated by pressing and holding the AC button for one second on the control panel.</p>
3	<p>AC Charging Port allows the unit to be charged using an AC Charger (supplied).</p>
4	<p>The USB Port charges some hand-held PDAs, cellphones, digital cameras, and camcorders.</p> <p>Note: Special USB power cables and adapters are required. These cables are not sold by Xantrex. Consult the owner's manual or the manufacturer of your device before plugging it to the USB port.</p>

Solar Panel Components

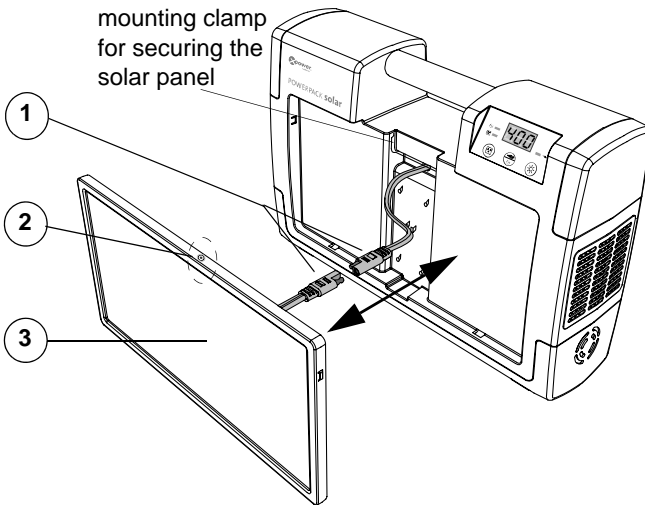

Figure 2-5 Solar Panel Component

Feature	Description
1	The male/female connectors attach to each other and connect the solar panel to the charging assembly inside the unit. You can remove the solar panel by unplugging the male/female connectors.
2	The Indicator Light flashes when the panel is receiving power from sunlight.
3	The Solar Panel is rated at 5 W and made of amorphous silicon material. The panel can be detached from the unit and extended up to one meter with its electrical cord. Note: Detaching the solar panel allows you to reposition it and not the whole unit for optimum sunlight exposure.

Backside Panel

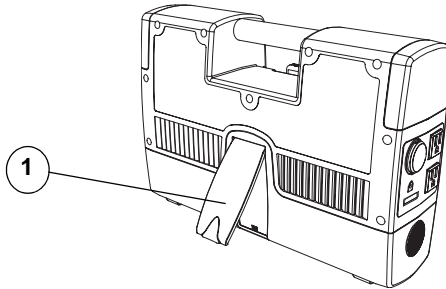

Figure 2-6 Backside Panel

Feature	Description
①	Back Stand provides support to the unit when slightly tilted upward. With the solar panel attached, you can use the stand to place the unit facing towards the sun

Accessories



Figure 2-7 Accessories

Feature	Description
①	AC Charger (part # 074-1004) attaches to the Powerpack Solar 400 via the AC charging port and lets you recharge from a household AC outlet.
②	DC Charging Cable (part # 449-0187-01-01) lets you recharge the Powerpack Solar 400 from a 12-volt system in a car, SUV, RV, or a boat. One of the plugs of the charging cable is equipped with a single and replaceable 8-amp, 32-volt, time-delayed fuse. Note: Press the DC/USB button to turn on the DC socket to enable recharging the battery from a vehicle or another DC source.

3 Operation

Chapter 3 explains how to operate the Powerpack Solar 400 efficiently. This chapter covers:

- Choosing a Location (page 10)
- Recharging the Powerpack Solar 400 (page 11)
- Interpreting Display Codes (page 19)
- Operating AC appliances (page 22)
- Operating 12-volt DC appliances (page 25)
- Charging USB Devices (page 27)
- Using the LED Lamp (page 29)
- Using the Back Stand (page 30)

Operating Conditions and Guidelines



CAUTION

Read all safety instructions and the operational procedures in the manual before operating the Powerpack Solar 400. Retain this manual for future reference.



CAUTION

The Powerpack Solar 400 is not intended for use as a UPS (Uninterruptible Power Supply).



WARNING: Limitations on Use

The XPower Powerpack Solar 400 is not intended for use in connection with life support systems or other medical equipment or devices.

Choosing a Location



WARNING: Fire or explosion

The Powerpack Solar 400 contains components that tend to produce arcs or sparks. To prevent fire or explosion, do not operate the Powerpack Solar 400 in compartments containing other exposed batteries, flammable materials, or in locations that require ignition-protected equipment.

The Powerpack Solar 400 should be operated only in locations that meet the following requirements.

Dry	Do not allow water or other liquids to drop or splash on the Powerpack Solar 400.
Cool	Ambient air temperature should be between 32 and 104°F (0 and 40°C) — the cooler the better within this range.
Ventilated	Leave at least 2" (5 cm) clearance around the Powerpack Solar 400 for air flow. Ensure that the ventilation openings are not obstructed.
Safe	Do not operate the unit in the same compartment with other exposed batteries or in any compartment capable of storing flammable liquids like gasoline.
Protected from battery gases	Do not operate the unit where it will be exposed to battery gases. These gases are very corrosive and prolonged exposure will damage the Powerpack Solar 400.

Recharging the Powerpack Solar 400 Battery

Important: Charge Before Use.

Charge the Powerpack Solar 400 for at least 48 hours immediately after purchase. Recharge after each use.

When storing for long periods of time, it is recommended to charge it once every month or at least once every three months. You can also store it with AC power supplied to the unit.

Failure to follow these instructions will void the product warranty.

You can recharge the battery by using:

- the AC Charger (supplied) plugged into a standard 120 Vac wall outlet,
- the DC Charging Cable (supplied) to recharge from your vehicle or a generator equipped with a regulated 12-volt battery charging outlet, or
- a 5 W solar panel (attached to the front of the unit).



CAUTION

Do not attempt to charge the Powerpack Solar 400 battery if it is frozen. Gradually warm the frozen battery to 32 °F (0 °C) before charging.



CAUTION

Do not operate AC or DC appliances while the Powerpack Solar 400 is being charged. Doing so may damage the charging components of the product and void the warranty.

Charging with the AC Charger

Using the AC Charger is the simplest method for recharging the battery. While charging from an AC source, the Charging Status LED indicator light on the Control Panel will flash intermittently. The indicator light will stay on when the battery has reached capacity.

Charging when the battery is fully discharged takes around 16 to 20 hours. If the wall outlet voltage is less than 120 Vac, it may take more than 20 hours to fully recharge the Powerpack Solar 400.

Note: After taking the unit out of the box and before using it for the first time, charge it for 48 hours to maximize battery life.

Powerpack Solar 400 AC Charging Feature

The Powerpack Solar 400 AC charging port has a regulated internal switch that monitors charging to prevent the battery from being overcharged. Once the battery reaches 100% charge level, the switch disconnects the charging source from the unit. The unit goes into a maintenance charge mode and allows the unit to remain connected to the AC Charging source until it's needed to power loads.

Important: Whenever possible, store the Powerpack Solar 400 with AC power supplied to the unit.

When storing without AC power available, charge it once every month or at least once every three months.

Failure to do so may damage the battery, render the unit inoperable, and void the product warranty.

1. Press and hold the AC button for one second to turn off the AC sockets.
2. Check that the indicator light is off.
3. Press and hold the DC/USB and Lamp buttons for one second to turn the DC socket, USB port, and the Lamp off.
4. Check that the indicator light is off.
5. Insert the AC Charger plug into the AC charging port.
6. Insert the AC Charger into a household 120 Vac outlet.
7. Check the Charging Status indicator light.

Note: A flashing light indicates that the unit is charging the battery. A solid light indicates that the battery is fully charged and on stand-by.

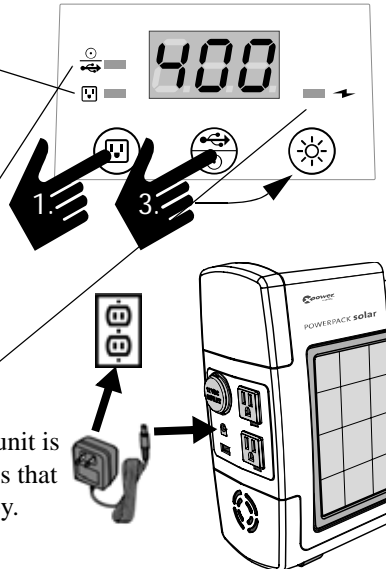

Figure 3-1 Charging with AC Power

Note: The Battery Charge (%) reading on the digital display is only accurate after the Powerpack Solar 400 has been disconnected from all appliances and all charging sources for 15 minutes.

Charging with the DC-to-DC Accessory Cable



WARNING: Fire and explosion hazard

Do not use this recharging method if your vehicle has abnormally high voltage electrical systems that operate above 15 Vdc. This may lead to accumulations of hydrogen, causing exposure to fire and explosion hazard. This is typically found in marine applications or on portable generators with DC output. Consult the vehicle's or generator's manual for DC output voltage information.

Important: Although the charge regulation circuitry for the AC charging method does not operate with the DC-to-DC charging method, most vehicle voltage regulators will ensure that the Powerpack Solar 400 is not overcharged.

The Powerpack Solar 400 comes with a DC Charging cable to allow the unit to be charged from a DC source such as an automobile, RV, or boat. The labeled and fused plug of the charging cable is equipped with a single and replaceable 8-amp, 32-volt, time-delayed fuse.

The vehicle to be used for charging must have a 12 Vdc power (or accessory) socket and must be running in order to charge the unit.

The DC input/output power socket (DC socket) is found on the side of the unit. Press and hold the DC/USB button for one second to activate the DC socket.



CAUTION

Do not leave the Powerpack Solar 400 permanently connected to the vehicle's 12 Vdc power socket. Disconnect the Powerpack Solar 400 from the socket when the vehicle's engine is turned off.

Note: The **Charging Status** indicator light will neither blink nor stay on when the Powerpack Solar 400 is recharged through the DC Charging Cable. The **Battery Charge (%)** reading on the digital display is only accurate after the Powerpack Solar 400 has been disconnected from all appliances and all charging sources for 15 minutes.

1. Open the plastic cover that protects the unit's DC socket.
2. Insert the labeled plug of the DC charging cable into the 12 Vdc power socket in the vehicle.

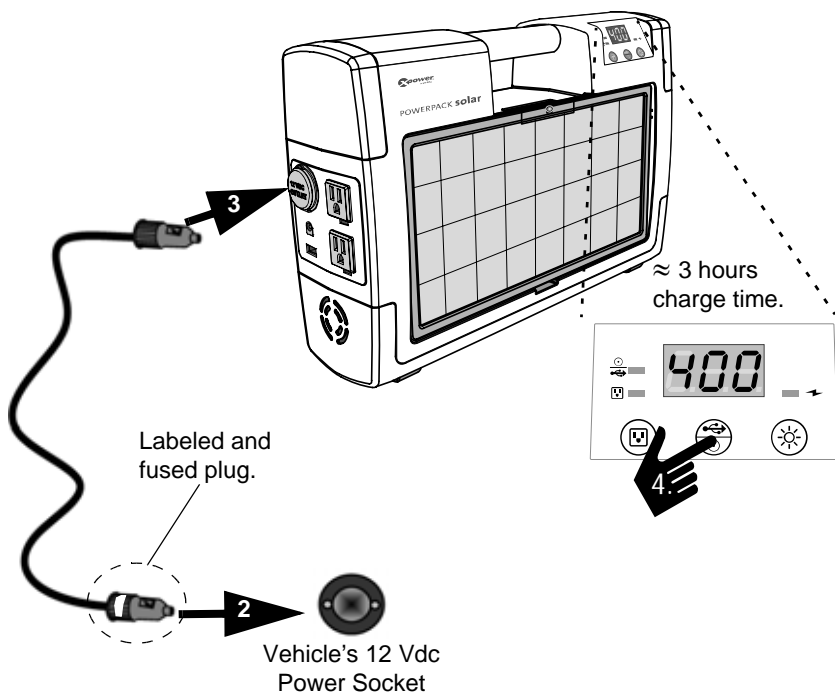

3. Insert the other plug of the DC charging cable into the DC socket on the side of the Powerpack Solar 400.

Note: The vehicle's 12 Vdc power socket must also be on. You have to start the engine and let it run to avoid draining the vehicle's battery.

4. Press and hold the DC/USB button for one second to activate the DC socket of the unit. This enables charging.
5. Disconnect the DC charging cable from both the unit and the vehicle when the vehicle is not running to avoid draining the vehicle's battery.

Figure 3-2 Charging with DC Power

Recharging with a Generator's Regulated 12 Vdc Outlet



WARNING: Fire and explosion hazard

The generator output must be intended for battery charging and have an output of 15 volts or less. An unregulated output or one that exceeds 15 Vdc can damage the battery.

This may lead to accumulations of hydrogen, causing exposure to fire and explosion hazard.

Refer to the Owner's Guide accompanying your generator for detailed instructions on connecting the generator to a unit like the Powerpack Solar 400.

You can recharge the battery of the Powerpack Solar 400 using a generator in several ways:

- Using the AC Charger to recharge the Powerpack Solar 400 from a generator is possible, but would require extended generator running time.
- Using a generator which has an auxiliary regulated DC output designed for charging 12-volt batteries. Most generators are equipped with them. Use this power source for faster charging.

Most of the Powerpack Solar 400's battery capacity will be recharged in a few hours.

Note: The **Battery Charge (%)** reading on the digital display is only accurate after the Powerpack Solar 400 has been disconnected from all appliances and all charging sources for 15 minutes.

Recharging From the Solar Panel

The solar panel is very convenient in places where you do not have access to AC or DC sources for charging. You can take the Powerpack Solar 400 with you and use the solar panel to charge it during the day when sunlight is available and have some power available in the night depending on how much energy was stored in the battery.

The 5 W solar panel is made of amorphous silicon material and mounted on the front side panel of the unit. The solar panel itself can be detached from the unit to allow you to position it better to catch direct sunlight.

The solar panel is connected to the charging assembly via an electrical cord that is joined together by male/female connectors.

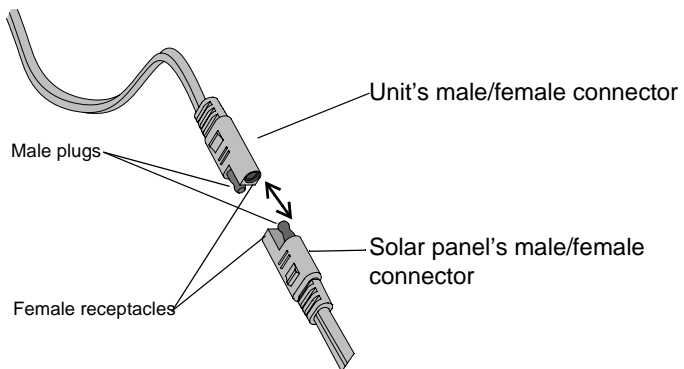

Figure 3-3 Male/female Connectors

To reconnect the solar panel to the unit:

1. Align the male plug of the solar panel's connector to the female receptacle of the unit's connector.
2. Align the female receptacle of the solar panel's connector to the male plug of the unit's connector.
3. Push the two connectors together until they are securely joined.

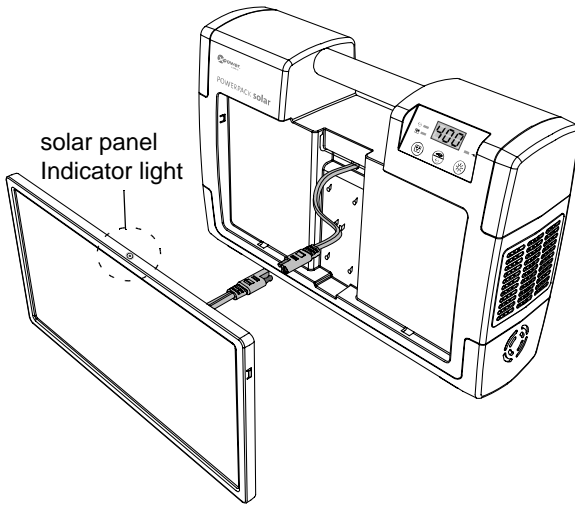

Figure 3-4 Charging with the Solar Panel

To recharge with a solar panel:

1. Connect the solar panel to the unit.
2. Place the solar panel in direct sunlight.

It takes about 45 hours in direct sunlight to recharge the Powerpack Solar 400 from the 5 W solar panel.

The indicator light located on the solar panel flashes intermittently when the panel receives power from sunlight. The control panel digital display and AC charging indicator lights do not come on when charging with the solar panel.

Note: You have the option to detach the solar panel from the unit or you can leave the solar panel attached while choosing a location and repositioning the unit to face direct sunlight.



CAUTION: Risk of Equipment Damage

Use only the supplied solar panel. Connecting an after-market or third-party solar panel to use for recharging the internal battery may damage the unit and void the warranty.

Interpreting Display Codes

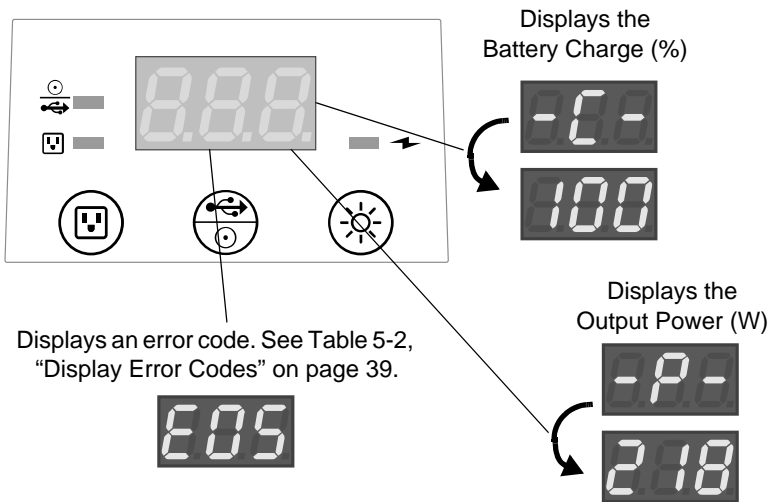

Figure 3-5 Different Display Codes

Checking Battery and AC Status

When either of the AC sockets, DC socket, or lamp is initially turned on, the digital display window flashes the different states of the battery charge and AC output power. The display automatically shuts off after 30 seconds to conserve energy from the internal battery.

While in use, pressing any of the buttons abruptly will also momentarily flash the different states of the battery charge and AC output power for 30 seconds.

Note: The Digital Display shows battery level and output power information. It flashes for 30 seconds before turning off automatically. It shows:

- the symbol **-P-** before displaying the inverter's Output Power in W (**0** to **400** W) and
- the symbol **-C-** before displaying the Battery Charge capacity status in % (**40** to **100**) or **L0** when capacity is below 40%.

Error codes are displayed as the error occurs. See Table 5-2, "Display Error Codes" on page 39

Operation

How to...	Required Condition	Required Action	Note
<p>Monitor total AC power consumed by appliances connected to the AC sockets.</p>	<p>Inverter's AC sockets are turned ON; AC charger is unplugged from the household AC outlet.</p>	<p>Press any of the control panel buttons abruptly.</p>	<p>The display window flashes battery capacity and power status.</p>
<p>Check Battery capacity status when: - AC is OFF - DC is OFF - Lamp is OFF</p>	<p>The AC charger must be unplugged from the Powerpack Solar 400. Wait 15 minutes or more before proceeding to the required action.</p>	<p>Press and hold for one second either the AC or DC/USB buttons.</p>	<p>The display window flashes battery capacity and power status.</p>
<p>Check Battery capacity status when: - either AC or DC is ON - Lamp is either ON or OFF</p>	<p>All appliances must be disconnected from the AC and DC power outlets; The AC charger must be unplugged from the Powerpack Solar 400's.</p>	<p>Press any of the control panel buttons abruptly.</p>	<p>The display window flashes battery capacity and power status. Battery Capacity reading is for reference use only. For accurate Battery Capacity reading, allow 15 minutes between charging/use and battery capacity check.</p>

How to...	Required Condition	Required Action	Note
Monitor Battery Charging status	<p>Inverter's AC, DC sockets and USB port are turned OFF;</p> <p>The LED lamp must be turned OFF;</p> <p>All appliances must be disconnected from the AC and DC power outlets;</p> <p>The AC charger must be plugged into the Powerpack Solar 400's AC charging port and also into a household AC outlet.</p>	<p>No action required.</p> <p>A flashing green Charging Status light indicates that AC charger is currently charging the battery.</p> <p>A steady green Charging Status light indicates that the Powerpack Solar 400's battery is fully charged and is ready for use.</p>	<p>Recharging with the supplied AC charger is a true "plug-in-and-forget" charging method.</p> <p>We recommend leaving the AC charger connected when the Powerpack Solar 400 is not in use to permanently maintain the battery in fully charged condition.</p>

AC Appliances

The Powerpack Solar 400 has two AC sockets for use with AC appliances. You can either plug the appliance directly into the AC socket on the Powerpack Solar 400 or you can use an AC power bar to increase the number of outlets available. However, the combined loads cannot exceed 320 W (2.66 A). The less power an appliance uses, the longer the Powerpack Solar 400 will operate before recharging is required.

Some appliances may be difficult or impossible to operate from the Powerpack Solar 400. They may have high surge requirements or may not be compatible with the modified sine wave output of the Powerpack Solar 400. See “High Surge Appliances” on page 24 and “Trouble Appliances” on page 24.

Important: *Know the size of the loads.*

320 watts AC Continuous Load

Amps x Volts = Watts

2.66 amps AC x 120 volts AC = 320 watts AC

Typical AC appliances that can be used on the Powerpack Solar 400 are listed in Table 3-1.

Table 3-1 Typical AC Appliances and Run Times

AC Appliance	Watts ^a	Hours ^b
Cordless telephone (stand by)	5	13.45
Home security system	5	13.45
Fluorescent work light	14	5.5
Fireplace fan	20	3.8
Laptop computer	25	3
Table lamp	40	1.48
Color TV – 13"	45	1.33
3/8" drill	190	17 minutes

a. Represents actual power consumption as measured on sample appliances.

b. Operating times assume a fully charged 10 Ah battery and may vary based on model/brand of appliance.

Operating AC Appliances

1. Press and hold the AC button for one second to activate the AC sockets.
2. Check the state-of-charge to ensure the battery is fully charged.
3. Open the AC socket cover.
4. Plug the appliance into one of the AC sockets and turn the appliance on.
5. Unplug or turn off the appliance when not in use to conserve energy.
6. Press and hold the AC button again to deactivate the AC sockets.

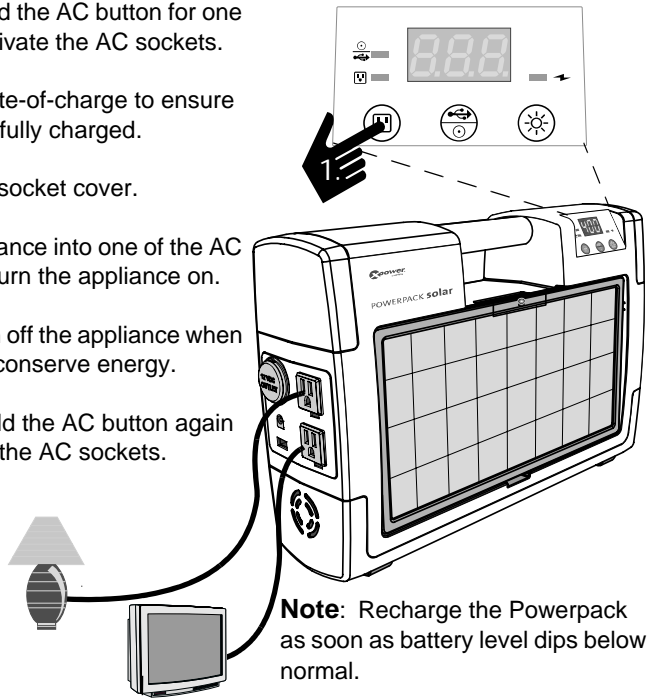

Note: Recharge the Powerpack as soon as battery level dips below normal.

Figure 3-6 Operating AC Appliances

Low-Battery Alarm

While in use, when the battery reaches 11 Vdc, the Low-Battery Alarm will sound and display an error code indicating that battery is low and the unit is about to be shutdown to prevent battery damage.

When the battery reaches 10.5 Vdc, the unit will automatically disconnect power to the AC sockets.

If the alarm sounds, disconnect any loads that may be in use and recharge the unit as soon as possible.

Overload Protection

In the event of an overload (> 400 W) or overheating, the Powerpack Solar 400 automatically sounds an alarm, displays an error code, and shuts down.

When this happens, remove the load immediately. The unit resets automatically after a few seconds.

High Surge Appliances

The wattage rating of AC appliances is the average power used by the appliance. Appliances such as televisions, computer monitors and appliances with motors consume much more power than their average rating when they are first switched on.

Although Powerpack Solar 400 can supply momentary surge power up to 600 W, some appliances may exceed the capabilities of the Powerpack Solar 400 and trigger the inverter's safety overload shutdown circuit.

Important: Do not use sump pumps, coffee makers, hair dryers, flat irons, or electric grills with the Powerpack Solar 400.

Trouble Appliances



CAUTION

The output of the Powerpack Solar 400 inverter is non-sinusoidal. Some equipment may be damaged by the inverter's modified sine wave (non-sinusoidal) output.

Some appliances, including the types listed below, may be damaged if they are connected to the inverter:

- Electronics that modulate RF (radio frequency) signals on the AC line will not work and may be damaged.

- Speed controllers found in some fans, power tools, kitchen appliances, and other loads may be damaged.
- Some chargers for small rechargeable batteries can be damaged. See “Precautions for Using Rechargeable Appliances” on page v for details.
- Metal halide arc (HMI Metallogen®) lamps can be damaged.

Note: If you are unsure about powering any device with the inverter, contact the manufacturer of the device.

12 Vdc Appliances

The Powerpack Solar 400 can operate one 12 Vdc auto, RV, marine, or other portable appliance that draws 12 A or less from a 12 Vdc power outlet or from a vehicle’s 12 Vdc accessory socket. The fewer watts a 12 Vdc appliance draws, the longer the Powerpack Solar 400 will operate before recharging is required.

Important: *Know the size of the loads.*

$$144 \text{ watts DC Maximum Load}$$

$$\text{Amps} \times \text{Volts} = \text{Watts}$$

$$12 \text{ amps DC} \times 12 \text{ volts DC} = 144 \text{ watts DC}$$

Typical 12 Vdc appliances that can be used on the Powerpack Solar 400 are listed in Table 3-2.

Table 3-2 Typical 12 V DC Appliances and Run Times

12 Vdc Appliance	Amps (A)	Hours ^a
LED light (built into the unit)	120 mA	45
Cellular telephone	0.5	15
Portable Cooler	5	1.8

a. Operating times assume a fully charged 10 Ah battery and may vary based on model or brand of appliance.

Operating DC Appliances

1. Press and hold the DC/USB button for one second to activate the DC socket.
2. Check the state-of-charge to ensure the battery is fully charged.
3. Open the DC socket cover.
4. Plug the DC appliance into the DC socket and turn the appliance on (if required).
5. Unplug or turn off the appliance when not in use to conserve energy.
6. Press and hold the DC/USB button again to deactivate the DC socket.

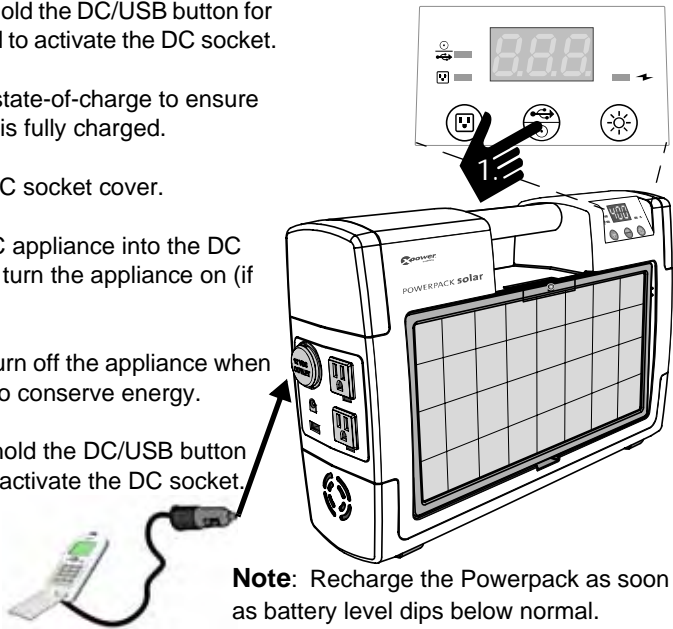

Figure 3-7 Operating DC Appliances

Low-Battery Alarm

While in use, when the battery reaches 11 Vdc, the Low-Battery Alarm will sound and display an error code indicating that battery is low and the unit is about to be shutdown to prevent battery damage.

When the battery reaches 10.5 Vdc, the unit will automatically disconnect power to the DC socket.

If the alarm sounds, disconnect any loads that may be in use and recharge the unit as soon as possible.

Overload Protection

The internal thermal protector will trip if the 12 Vdc appliance draws more than 12 A (or has a short-circuit defect).

If this occurs, unplug the 12 Vdc appliance. The internal thermal protector automatically resets after a few seconds.

USB Devices

The Powerpack Solar 400 can charge one USB-chargeable device through its USB port found below the AC charging port on the power socket side panel of the unit. Compatible devices include most MP3 players, PDAs, digital cameras, and camcorders that have internal batteries which can be charged via the USB port of a desktop/laptop computer.

USB-chargeable devices usually include a special USB cable (not supplied) that attaches one end to the USB port and the other end to the device.

Table 3-3 Typical USB Devices and Charge Times

USB Device	Battery Capacity (Ah)	Hours
iPod™ nano	0.75	2.7
Blackberry™	0.9	2.6

Important: Connect your USB device to the USB port and turn the AC button on to begin charging your device.

Note: Some USB devices allow simultaneous charging and usage. Some have to be turned off to enable charging. Consult your device's operating manual to find out how your device works.

Charging Devices via the USB Port

1. Press and hold the DC/USB button for one second to activate the USB port.
2. Check the state-of-charge to ensure the battery is fully charged.
3. Plug the USB device using a USB cable (not supplied) to the USB port on the side of the unit.
4. Unplug the USB device when fully charged.
5. Press and hold the DC/USB button again to deactivate the DC socket.

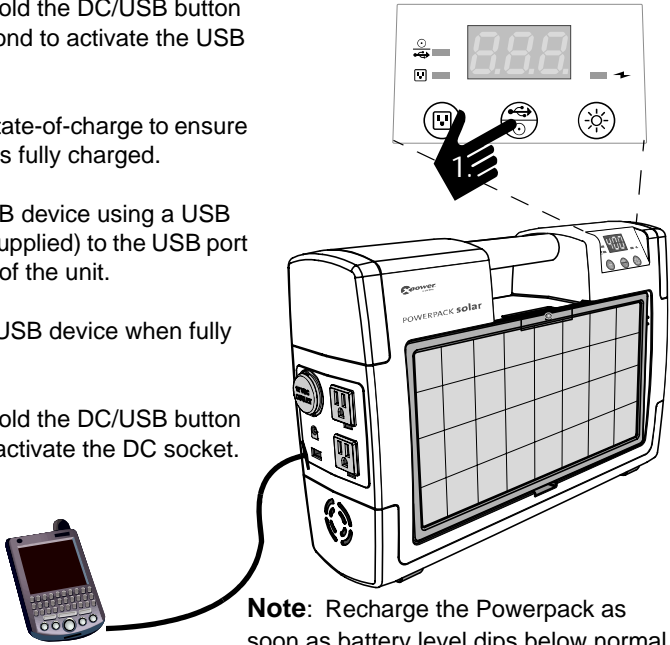

Note: Recharge the Powerpack as soon as battery level dips below normal.

Figure 3-8 Charging USB Devices

Low Battery Alarm

While in use, when the battery reaches 11 Vdc, the Low-Battery Alarm will sound and display an error code indicating that battery is low and the unit is about to be shutdown to prevent battery damage.

When the battery reaches 10.5 Vdc, the unit will automatically disconnect power to the USB outlet.

If the alarm sounds, disconnect any loads that may be in use and recharge the unit as soon as possible.

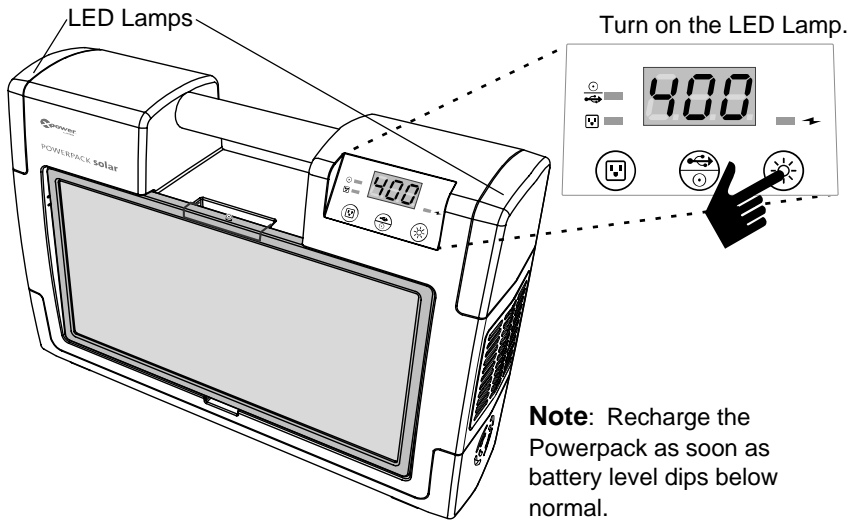

Figure 3-9 LED Lamp Controls

Using the LED Lamps

The Powerpack Solar 400 includes emergency lighting that provides a flood-light effect to surrounding area.

The lamps are located on each side of the unit. Each lamp has six hi-bright LEDs that provide illumination.

Low Battery Alarm

While in use, when the battery reaches 11 Vdc, the Low-Battery Alarm will sound indicating that battery is low and the unit is about to be shutdown to prevent battery damage.

When the battery reaches 10.5 Vdc, the unit will automatically disconnect power to the lamps.

If the alarm sounds, recharge the unit as soon as possible.

Using the Back Stand

The Powerpack Solar 400 is equipped with a back stand located in the middle of the backside panel.

You can use the stand to position the unit to face slightly upward especially when you place it on the floor during operation.

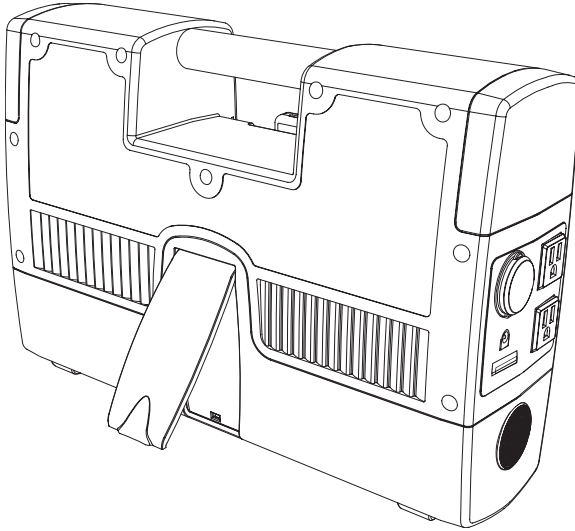

Figure 3-10 Back Stand

4 Maintenance

Chapter 4 provides information on maintaining your internal battery and recharging options for the internal battery.

Routine maintenance is required to keep your Powerpack Solar 400 operating properly. Occasionally clean the exterior of the unit with a damp cloth to remove the accumulated dust and dirt.



WARNING: Shock hazard

Disconnect all sources of AC power and DC power before performing any type of maintenance.

Solar Panel Maintenance

The cells of the solar panel are protected by a special plastic material. Use a soft damp cloth to wipe off dirt, oil, and other debris that may significantly block the cells of the solar panel and degrade its ability to collect sunlight.

Do not immerse the solar panel in water.

Battery Maintenance

All rechargeable batteries gradually discharge when left standing and need to be recharged periodically to maintain maximum battery capacity. The AC Charger supplied with the Powerpack Solar 400 is designed to regulate the charging process, ensuring that the battery is always fully charged but never overcharged. To ensure safe recharging and maximum battery life, recharge the Powerpack Solar 400 only with the supplied AC Charger or the Solar Panel.



CAUTION

Due to inherent self-discharge, lead acid batteries must be charged at least every 3 months (once a month is recommended), especially in a warm environment. Leaving a battery in a discharged state, or not recharging regularly, may result in permanent battery damage. ***Damage to the battery caused by neglect is not covered by the product warranty.***

Battery Life

The high quality battery used in the Powerpack Solar 400 will serve as a reliable power source for years when properly maintained.

To maximize battery life, it is important to recharge the Powerpack Solar 400 battery after each use.

Important: Recharge the Powerpack Solar 400 fully at least every three months (once a month is recommended) if it is placed in storage or in a vehicle trunk. Store in a location that maintains a temperature range between 32 and 86 °F (0 and 30 °C).



CAUTION

Discharging the internal battery below 10.0 V will damage the battery and shorten its life.

Recycling

The Powerpack Solar 400 is designed to provide years of service. However, when the internal battery reaches the end of its service life, the Powerpack Solar 400 itself is no longer useful. The internal battery is not designed to be user replaceable.

Because the internal battery contains lead, which can be hazardous to the environment, the Powerpack Solar 400 should be recycled or safely disposed of at your local recycling depot.

Do not dispose of the Powerpack Solar 400 with common household waste. Please ask your local authorities about recycling services that are available in your area.

The following website provides additional recycling information:

<http://www.earth911.org/master.asp>

5

Troubleshooting

Troubleshooting will help you identify the common problems than can occur with the Powerpack Solar 400.

Read this chapter before calling Customer Service.

If you cannot solve the problem with the Powerpack Solar 400, record the information asked for on “Information About Your System” on page 49 and then contact your dealer.

Common Problems

Buzz in Audio Equipment

Some inexpensive stereo systems have inadequate internal power-supply filtering and may buzz slightly when powered by the Powerpack Solar 400. The best solution to eliminate the buzzing is to use an audio system with a good quality filter.

Television Interference

The Powerpack Solar 400 is shielded to minimize interference with TV signals. If TV signals are weak, you may see interference in the form of lines scrolling across the TV screen. Try one of the following suggestions to minimize or eliminate the interference:

- Use an extension cord to increase the distance between the Powerpack Solar 400 and the TV, antenna, and cables.

- Adjust the orientation of the Powerpack Solar 400, television, antenna, and cables.
- Maximize TV signal strength by using a better antenna. Use a shielded antenna cable where possible.
- Try a different TV. Different models vary considerably in their susceptibility to interference.

Troubleshooting Reference



WARNING: Electric shock hazard

Do not remove the cover of the Powerpack Solar 400 or disassemble the Powerpack Solar 400. The Powerpack Solar 400 does not contain any internal user-serviceable parts and attempting to service the unit yourself could result in electrical shock or burn.

Table 5-1 Troubleshooting reference

Problem	Possible Cause	Solution
Digital display shows ED 1 and alarm sounds.	Battery capacity is low.	Unplug all appliances and start recharging the Powerpack Solar 400.
Digital display shows ED 2 and alarm sounds.	Battery voltage is too high.	Check the battery charging system. For example, if you are charging using an AC charger, make sure that you are using the AC charger that came with the Powerpack Solar 400.
Digital display shows ED 3 and alarm sounds.	The inverter has overheated due to improper ventilation or excessively warm conditions.	Unplug all appliances and allow the Powerpack Solar 400 to cool down for 15 minutes or more. Clear the ventilation grill of accumulated dust, dirt, or other debris. Remove objects covering the unit, then restart the Powerpack Solar 400. Move to a cooler environment.

Table 5-1 Troubleshooting reference

Problem	Possible Cause	Solution
Digital display shows E04 and alarm sounds.	The appliance connected to the AC socket (or DC socket) exceeds the capability of the Powerpack Solar 400.	Unplug the appliance and confirm that the appliance’s power requirement is 320 W or less (144 W or less) before attempting to restart the appliance.
Digital display shows E05 and alarm sounds.	The appliance connected to the AC socket has a short circuit.	Unplug and check the appliance.
Digital display shows E07 and alarm sounds.	Internal battery voltage falls below the operational voltage capacity.	Unplug all appliances and start recharging the Powerpack Solar 400.
Measured AC output voltage is too low.	<p data-bbox="288 742 511 867">Use of an average-reading AC voltmeter to read output voltage.</p> <p data-bbox="288 1029 483 1122">Internal battery is almost fully discharged.</p>	<p data-bbox="556 742 953 992">The modified sine wave (MSW) output of the Powerpack Solar 400 requires a true RMS reading meter, such as the Fluke 87 series, for accurate measurement. A typical reading on a non-true RMS meter should show between 98 Vac to 120 Vac.</p> <p data-bbox="556 1029 953 1089">Verify battery status and recharge the Powerpack Solar 400 as necessary.</p> <p data-bbox="556 1127 953 1279">“Battery Charge %” reading on the digital display is only accurate when the Powerpack Solar 400 has been disconnected from all appliances and all charging sources for 15 minutes.</p>

Table 5-1 Troubleshooting reference

Problem	Possible Cause	Solution
Run time is less than expected.	<p>Internal battery is not fully charged.</p> <p>AC appliance power consumption is higher than expected.</p>	<p>Recharge using the AC Charger, until Charging Status light is steady.</p> <p>Check AC appliance power or wattage rating (or current draw for 12 Vdc appliances) and compare with Table 3-1 on page 22 and Table 3-2 on page 25.</p> <p><i>For additional information on battery run times, see the Battery App Note under the Support Section at www.xantrex.com.</i></p>
Charging Status light is OFF when AC Charger is connected.	<p>No AC power at the AC wall outlet.</p> <p>AC Charger is faulty.</p>	<p>Ensure power is available at the AC wall outlet.</p> <p>Replace the AC Charger.</p>
USB port not charging external device.	<p>USB port is turned off.</p> <p>Internal battery is discharged.</p>	<p>Press and hold the DC/USB button to activate the USB port.</p> <p>Recharge the Powerpack Solar 400.</p>
Powerpack Solar 400 does not recharge using the supplied DC-to-DC charging cable.	<p>The fuse at the end of the charging cable has blown.</p> <p>DC socket is turned off.</p>	<p>Check the fuse and replace, if blown, with a similar 8-amp, 32-volt time-delayed fuse.</p> <p>Check the DC power source and make sure that it is rated at 12 V.</p> <p>Check the DC socket of the vehicle and make sure it has the correct polarity before plugging the charging cable.</p> <p>Press and hold the DC/USB button to activate the DC socket.</p>

Table 5-1 Troubleshooting reference

Problem	Possible Cause	Solution
LED Lamps not lighting.	Internal battery is discharged.	Recharge the Powerpack Solar 400.
Solar panel does not seem to be charging the internal battery.	Insufficient exposure to direct sunlight.	Reposition the solar panel to maximize exposure to direct sunlight.
	Solar panel connector is not connected securely to the unit's connector.	Make sure that the connectors are inserted firmly into each other.
	Solar panel's electrical cord may be damaged or frayed.	Check that the cord is not damaged nor wire exposed.

Table 5-2 Display Error Codes

Display Code	Meaning
<i>E01</i>	Under voltage alarm (internal battery)
<i>E02</i>	Over voltage alarm (internal battery)
<i>E03</i>	Over temperature alarm
<i>E04</i>	Overload alarm (from AC power draw)
<i>E05</i>	Short circuit alarm (from AC power draw)
<i>E06</i>	Not-in-use
<i>E07</i>	Under voltage shut down (internal battery)

A Specifications

Chapter A, “Specifications” includes the electrical, mechanical, and environmental specifications for the Powerpack Solar 400.

Electrical Specifications

AC Power Section	
Output power <ul style="list-style-type: none">• Continuous output power• Peak AC output power• AC output surge capacity	320 W 400 W 640 W
Output voltage	115 ± 10 Vac RMS
Output frequency	60 Hz ± 1 Hz
Output wave form	modified sine wave (non-sinusoidal)
Total Harmonic Distortion (THD)	32.7%
Maximum Single Harmonic	30%
No load current draw	<0.40 Adc
Input voltage range	10.5 to 15.5 Vdc
Over temperature shutdown feature	Yes, automatic reset
Overload shutdown feature	Yes, automatic reset
AC output short circuit protection feature	Yes, automatic reset
Fuse (internal, non-replaceable)	2 × 25 A

Specifications

Normal operating temperature	77 °F (25 °C)
Operating temperature range	32 – 104 °F (0 – 40 °C)
Storage temperature range	-4 – 140 °F (-20 – 60 °C)

DC Power Section	
DC output power (maximum continuous load)	12 A with overload protection and automatic reset
DC charger input socket polarity	Female, center positive
Built-in ambient LED light	12 hi-bright white LEDs with diffuser

Internal Battery Section	
Internal battery type	sealed, AGM (Absorbed Glass Mat) lead acid
Internal battery voltage (nominal)	12 Vdc
Internal battery capacity (minimum)	10 Ah
Maximum charge current	0.75 Adc
Peak charging voltage (nominal)	14.8 V
Charge restart voltage (nominal)	12.8 V
Low battery alarm	11.0 Vdc
Low battery shutdown	10.5 Vdc
High battery voltage shutdown	15.5 Vdc

USB Section	
Output Voltage (No Load)	5 Vdc
Output Voltage current	500mAdc

Solar Panel Section	
Power	5 W
Panel Type	Amorphous Silicon
Portability	Detachable from main unit
Connector Type	Male/female connector

Accessories	
DC-to-DC charge cable (replacement part # 449-0187-01-01)	39" (1 m) 18 AWG with male-to-male lighter plugs. One plug is equipped with an 8-amp, 32-volt time-delayed fuse.
AC Charger (replacement part # 074-1004)	Input: 120 ± 10 Vac, 60 Hz Output: 13.5Vdc, 750mAdc

Physical Specifications

Height	10 ¼" (26 cm)
Width	15" (38 cm)
Depth	4 ½" (11.5 cm)
Weight (net)	12.3 lb. (5.6 kg)

Important: All specifications are subject to change without notice.

Warranty and Return Information

Warranty

What does this warranty cover? This Limited Warranty is provided by Xantrex Technology Inc. ("Xantrex") and covers defects in workmanship and materials in your XPower Powerpack Solar 400. This warranty period lasts for 6 months from the date of purchase at the point of sale to you, the original end user customer. You will be required to demonstrate proof of purchase to make warranty claims.

This Limited Warranty is transferable to subsequent owners but only for the unexpired portion of the Warranty Period. Subsequent owners also require original proof of purchase as described in "What proof of purchase is required?"

What will Xantrex do? Xantrex will, at its option, repair or replace the defective product free of charge, provided that you notify Xantrex of the product defect within the Warranty Period, and provided that Xantrex through inspection establishes the existence of such a defect and that it is covered by this Limited Warranty.

Xantrex will, at its option, use new and/or reconditioned parts in performing warranty repair and building replacement products. Xantrex reserves the right to use parts or products of original or improved design in the repair or replacement. If Xantrex repairs or replaces a product, its warranty continues for the remaining portion of the original Warranty Period or 90 days from the date of the return shipment to the customer, whichever is greater. All replaced products and all parts removed from repaired products become the property of Xantrex.

Xantrex covers both parts and labor necessary to repair the product, and return shipment to the customer via a Xantrex-selected non-expedited surface freight within the contiguous United States and Canada. Alaska and Hawaii are excluded. Contact Xantrex Customer Service for details on freight policy for return shipments outside of the contiguous United States and Canada.

How do you get service? If your product requires troubleshooting or warranty service, contact your merchant. If you are unable to contact your merchant, or the merchant is unable to provide service, contact Xantrex directly at:

Telephone: 1 888 291 3544 (toll free North America)

Fax: 1 800 994 7828 (toll free North America)

1 360 925 5143 (direct)

Email: customerservice@xantrex.com

Direct returns may be performed according to the Xantrex Return Material Authorization Policy described in your product manual. For some products, Xantrex maintains a network of regional Authorized Service Centers. Call Xantrex or check our website to see if your product can be repaired at one of these facilities.

Warranty and Return

What proof of purchase is required? In any warranty claim, dated proof of purchase must accompany the product and the product must not have been disassembled or modified without prior written authorization by Xantrex.

Proof of purchase may be in any one of the following forms:

- The dated purchase receipt from the original purchase of the product at point of sale to the end user, or
- The dated dealer invoice or purchase receipt showing original equipment manufacturer (OEM) status, or
- The dated invoice or purchase receipt showing the product exchanged under warranty

What does this warranty not cover? This Limited Warranty does not cover normal wear and tear of the product or costs related to the removal, installation, or troubleshooting of the customer's electrical systems. This warranty does not apply to and Xantrex will not be responsible for any defect in or damage to:

- a) the product if it has been misused, neglected, improperly installed, physically damaged or altered, either internally or externally, or damaged from improper use or use in an unsuitable environment;
- b) the product if it has been subjected to fire, water, generalized corrosion, biological infestations, or input voltage that creates operating conditions beyond the maximum or minimum limits listed in the Xantrex product specifications including high input voltage from generators and lightning strikes;
- c) the product if repairs have been done to it other than by Xantrex or its authorized service centers (hereafter "ASCs");
- d) the product if it is used as a component part of a product expressly warranted by another manufacturer;
- e) the product if its original identification (trade-mark, serial number) markings have been defaced, altered, or removed.

Disclaimer

Product

THIS LIMITED WARRANTY IS THE SOLE AND EXCLUSIVE WARRANTY PROVIDED BY XANTREX IN CONNECTION WITH YOUR XANTREX PRODUCT AND IS, WHERE PERMITTED BY LAW, IN LIEU OF ALL OTHER WARRANTIES, CONDITIONS, GUARANTEES, REPRESENTATIONS, OBLIGATIONS AND LIABILITIES, EXPRESS OR IMPLIED, STATUTORY OR OTHERWISE IN CONNECTION WITH THE PRODUCT, HOWEVER ARISING (WHETHER BY CONTRACT, TORT, NEGLIGENCE, PRINCIPLES OF MANUFACTURER'S LIABILITY, OPERATION OF LAW, CONDUCT, STATEMENT OR OTHERWISE), INCLUDING WITHOUT RESTRICTION ANY IMPLIED WARRANTY OR CONDITION OF QUALITY, MERCHANTABILITY OR FITNESS FOR A PARTICULAR PURPOSE. ANY IMPLIED WARRANTY OF MERCHANTABILITY OR FITNESS FOR A PARTICULAR PURPOSE TO THE EXTENT REQUIRED UNDER APPLICABLE LAW TO APPLY TO THE PRODUCT SHALL BE LIMITED IN DURATION TO THE PERIOD STIPULATED UNDER THIS LIMITED WARRANTY.

IN NO EVENT WILL XANTREX BE LIABLE FOR ANY SPECIAL, INDIRECT, INCIDENTAL OR CONSEQUENTIAL DAMAGES, LOSSES, COSTS OR EXPENSES HOWEVER ARISING WHETHER IN CONTRACT OR TORT INCLUDING WITHOUT RESTRICTION ANY ECONOMIC LOSSES OF ANY KIND, ANY LOSS OR DAMAGE TO PROPERTY, ANY

PERSONAL INJURY, ANY DAMAGE OR INJURY ARISING FROM OR AS A RESULT OF MISUSE OR ABUSE, OR THE INCORRECT INSTALLATION, INTEGRATION OR OPERATION OF THE PRODUCT.

Exclusions

If this product is a consumer product, federal law does not allow an exclusion of implied warranties. To the extent you are entitled to implied warranties under federal law, to the extent permitted by applicable law they are limited to the duration of this Limited Warranty. Some states and provinces do not allow limitations or exclusions on implied warranties or on the duration of an implied warranty or on the limitation or exclusion of incidental or consequential damages, so the above limitation(s) or exclusion(s) may not apply to you. This Limited Warranty gives you specific legal rights. You may have other rights which may vary from state to state or province to province.

Return Material Authorization Policy

Before returning a product directly to Xantrex you must obtain a Return Material Authorization (RMA) number and the correct factory "Ship To" address. Products must also be shipped prepaid. Product shipments will be refused and returned at your expense if they are unauthorized, returned without an RMA number clearly marked on the outside of the shipping box, if they are shipped collect, or if they are shipped to the wrong location.

When you contact Xantrex to obtain service, please have your instruction manual ready for reference and be prepared to supply:

- The serial number of your product
- Information about the installation and use of the unit
- Information about the failure and/or reason for the return
- A copy of your dated proof of purchase

Record these details in "Information About Your System" on page 49.

Return Procedure

1. Package the unit safely, preferably using the original box and packing materials. Please ensure that your product is shipped fully insured in the original packaging or equivalent. This warranty will not apply where the product is damaged due to improper packaging.
2. Include the following:
 - The RMA number supplied by Xantrex Technology Inc. clearly marked on the outside of the box.
 - A return address where the unit can be shipped. Post office boxes are not acceptable.
 - A contact telephone number where you can be reached during work hours.
 - A brief description of the problem.
3. Ship the unit prepaid to the address provided by your Xantrex customer service representative.

If you are returning a product from outside of the USA or Canada In addition to the above, you **MUST** include return freight funds and are fully responsible for all documents, duties, tariffs, and deposits.

If you are returning a product to a Xantrex Authorized Service Center (ASC) A Xantrex return material authorization (RMA) number is not required. However, you must contact the ASC prior to returning the product or presenting the unit to verify any return procedures that may apply to that particular facility and that the ASC repairs this particular Xantrex product.

Out of Warranty Service

If the warranty period for your XPower Powerpack Solar 400 has expired, if the unit was damaged by misuse or incorrect installation, if other conditions of the warranty have not been met, or if no dated proof of purchase is available, your unit may be serviced or replaced for a flat fee.

To return your XPower Powerpack Solar 400 for out of warranty service, contact Xantrex Customer Service for a Return Material Authorization (RMA) number and follow the other steps outlined in “Return Procedure” on page 47.

Payment options such as credit card or money order will be explained by the Customer Service Representative. In cases where the minimum flat fee does not apply, as with incomplete units or units with excessive damage, an additional fee will be charged. If applicable, you will be contacted by Customer Service once your unit has been received.

Information About Your System

As soon as you open your XPower Powerpack Solar 400 package, record the following information and be sure to keep your proof of purchase.

- p Serial Number _____
- p Product Number 852-2071
- p Purchased From _____
- p Purchase Date _____

If you need to contact Customer Service, please record the following details before calling. This information will help our representatives give you better service.

- p Type of installation [e.g. RV, truck, vehicle, home] _____
 - p Length of time inverter has been installed _____
 - p Battery/battery bank size _____
 - p DC wiring size and length _____
 - p Warning, Error or Panel Fault Message _____
 - p Appliances operating when problem occurred _____
 - p Description of problem _____
-
-

