

NordicTrack[®] **3500 R**

Class H Fitness Product

Model No. NETL15520

Serial No. _____

Write the serial number in the space above for reference.

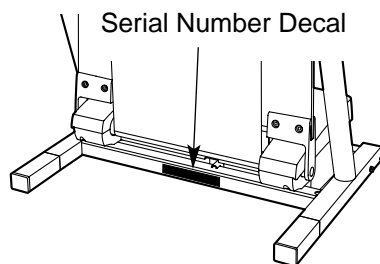

USER'S MANUAL

QUESTIONS?

As a manufacturer, we are committed to providing complete customer satisfaction. If you have questions, or if there are missing parts, please call:

08457 089 009

Or write:

ICON Health & Fitness, Ltd.
Unit 4
Revie Road Industrial Estate
Revie Road
Beston
Leeds
LS11 8JG

email: csuk@iconeurope.com

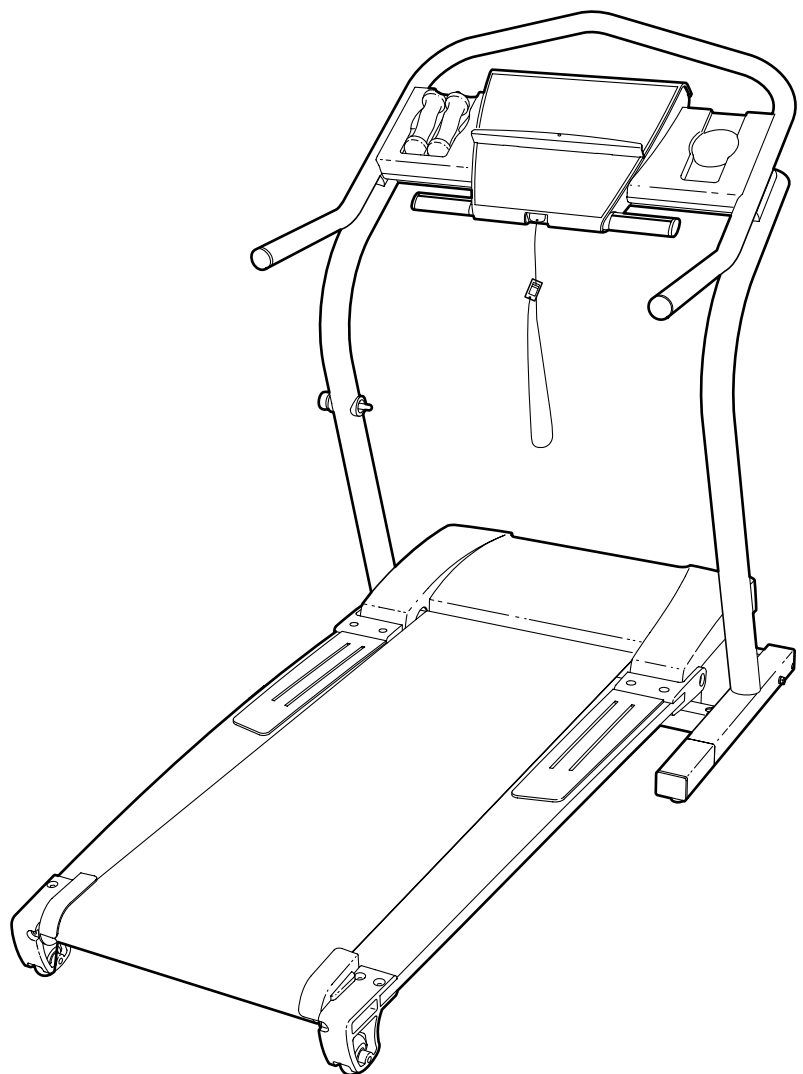

⚠ CAUTION

Read all precautions and instructions in this manual before using this equipment. Save this manual for future reference.



Visit our website at

www.iconeurope.com



NordicTrack®

3500 R

TABLE OF CONTENTS

IMPORTANT PRECAUTIONS	3
BEFORE YOU BEGIN	5
ASSEMBLY	6
HOW TO USE THE CHEST PULSE SENSOR	8
OPERATION AND ADJUSTMENT	9
HOW TO FOLD AND MOVE THE TREADMILL	26
TROUBLESHOOTING	27
CONDITIONING GUIDELINES	29
PART LIST	30
ORDERING REPLACEMENT PARTS	Back Cover

Note: An EXPLODED DRAWING is attached in the centre of this manual.

IMPORTANT PRECAUTIONS

⚠ WARNING: To reduce the risk of burns, fire, electric shock, or injury to persons, read the following important precautions and information before operating the treadmill.

1. It is the responsibility of the owner to ensure that all users of this treadmill are adequately informed of all warnings and precautions.
2. Use the treadmill only as described in this manual.
3. Place the treadmill on a level surface, with at least 2,5 m (8 ft.) of clearance behind it and 0.5 m (2 ft.) on each side. Do not place the treadmill on a surface that blocks any air openings. To protect the floor or carpet from damage, place a mat under the treadmill.
4. Keep the treadmill indoors, away from moisture and dust. Do not put the treadmill in a garage or covered patio, or near water.
5. Do not operate the treadmill where aerosol products are used or where oxygen is being administered.
6. Keep children under the age of 12 and pets away from the treadmill at all times.
7. The treadmill should not be used by persons weighing more than 115 kg (250 lbs.).
8. Never allow more than one person on the treadmill at a time.
9. Wear appropriate exercise clothes when using the treadmill. Do not wear loose clothes that could become caught in the treadmill. Athletic support clothes are recommended for both men and women. Always wear athletic shoes. Never use the treadmill with bare feet, wearing only stockings, or in sandals.
10. When connecting the power cord (see page 9), plug the power cord into an earthed circuit. No other appliance should be on the same circuit. When replacing the fuse, an ASTA approved BS1362 type should be fitted to the fuse carrier. A 13 amp fuse should be used.
11. If an extension cord is needed, use only a 3-conductor, 1 mm² (14-gauge) cord that is no longer than 1.5 m (5 ft.).
12. Keep the power cord and the surge suppressor away from heated surfaces.
13. Never move the walking belt whilst the power is turned off. Do not operate the treadmill if the power cord or plug is damaged, or if the treadmill is not working properly. (See **BEFORE YOU BEGIN** on page 5 if the treadmill is not working properly.)
14. Never start the treadmill whilst you are standing on the walking belt. Always hold the handrails whilst using the treadmill.
15. The treadmill is capable of high speeds. Adjust the speed in small increments to avoid sudden jumps in speed.
16. Using hand weights and not holding the handrails may compromise your ability to maintain your balance. Hand weights should be used only by experienced users.
17. The pulse sensors are not medical devices. Various factors, including the user's movement, may affect the accuracy of heart rate readings. The pulse sensors are intended only as exercise aids in determining heart rate trends in general.
18. Never leave the treadmill unattended whilst it is running. Always remove the key, unplug the power cord, and move the on/off switch to the off position when the treadmill is not in use. (See the drawing on page 5 for the location of the on/off switch.)
19. Do not change the incline of the treadmill by placing objects under the treadmill.
20. Do not attempt to raise, lower, or move the treadmill until it is properly assembled. (See **ASSEMBLY** on page 6, and **HOW TO FOLD AND MOVE THE TREADMILL** on page 26.) You must be able to safely lift 20 kg (45 lbs.) in order to raise, lower, or move the treadmill.
21. When folding or moving the treadmill, make sure that the storage latch is fully closed.

22. When using iFIT.com CD's and videos, an electronic "chirping" sound will alert you when the speed and/or incline of the treadmill is about to change. Always listen for the "chirp" and be prepared for speed and/or incline changes. In some instances, the speed and/or incline may change before the personal trainer describes the change.

23. When using iFIT.com CD's and videos, you can manually override the speed and incline settings at any time by pressing the speed and incline buttons. However, when the next "chirp" is heard, the speed and/or incline will change to the next settings of the CD or video program.

24. Always remove iFIT.com CD's and videos from your CD player or VCR when you are not using them.

25. Inspect and properly tighten all parts of the treadmill regularly.

26. Never insert or drop any object into any opening.

27. **DANGER:** Always unplug the power cord immediately after use, before cleaning the treadmill, and before performing the maintenance and adjustment procedures described in this manual. Never remove the motor hood unless instructed to do so by an authorised service representative. Servicing other than the procedures in this manual should be performed by an authorised service representative only.

28. This treadmill is intended for in-home use only. Do not use this treadmill in any commercial, rental, or institutional setting.

⚠ WARNING: Before beginning this or any exercise program, consult your physician. This is especially important for persons over the age of 35 or persons with pre-existing health problems. Read all instructions before using. ICON assumes no responsibility for personal injury or property damage sustained by or through the use of this product.

SAVE THESE INSTRUCTIONS

The decal shown at the right has been placed on your treadmill. If the decal is missing or illegible, please call our Customer Service Department to order a free replacement decal (see **ORDERING REPLACEMENT PARTS** on the back cover of this manual). Apply the decal in the location shown.

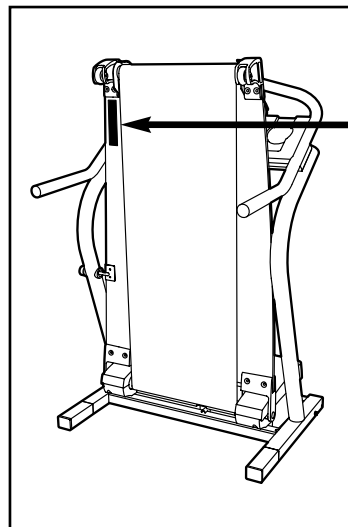



Note: The decal at the right is shown at 50% of actual size.

⚠ WARNING:

Protect yourself and others from risk of serious injury. Read the user's manual and :

-  •Stand only on the side rails when starting or stopping treadmill.
- Change speed in small increments.
- Hold handrails to prevent falling, and always wear the safety clip while operating treadmill.
- Stop if you feel faint, dizzy, or short of breath.
- Fully engage storage latch before treadmill is moved or stored.
- Reduce incline to its lowest level before folding treadmill into storage position.

-  •Never allow children on or around treadmill.
- Remove key when not in use.

-  •Keep clothing, fingers, and hair away from moving belt.
- Never try to adjust or fix the belt while it is moving.
- Always wear athletic shoes while operating treadmill.

BEFORE YOU BEGIN

Congratulations for selecting the new NordicTrack® 3500 R treadmill. The 3500 R treadmill combines advanced technology with innovative design to help you get the most from your workouts in the convenience of your home. And when you're not exercising, the unique 3500 R can be folded up, requiring less than half the floor space of other treadmills.

ing the manual, please call our Customer Service Department at **08457 089 009**. To help us assist you, please note the product model number and serial number before calling. The model number is NETL15520. The serial number can be found on a decal attached to the treadmill (see the front cover of this manual for the location).

For your benefit, read this manual carefully before using the treadmill. If you have questions after read-

Before reading further, please familiarise yourself with the parts that are labelled in the drawing below.

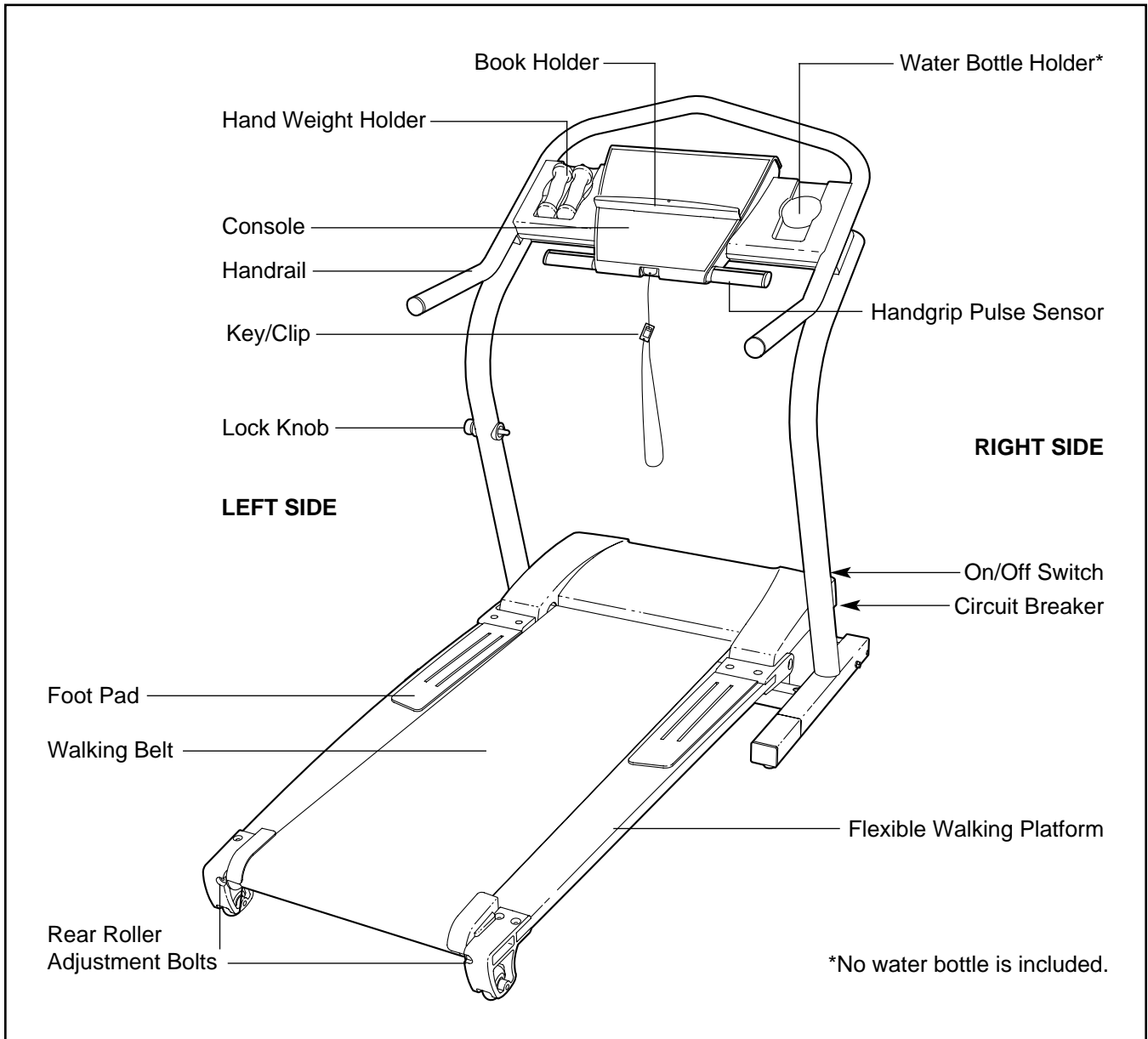

ASSEMBLY

Assembly requires two people. Set the treadmill in a cleared area and remove all packing materials. Do not dispose of the packing materials until assembly is completed. **Assembly requires the included allen wrench and your own phillips screwdriver, adjustable spanner and wire cutters.**

Note: The underside of the treadmill walking belt is coated with high-performance lubricant. During shipping, a small amount of lubricant may be transferred to the top of the treadmill or the shipping carton. This is a normal condition and does not affect treadmill performance. If there is lubricant on top of the walking belt or foot pads, simply wipe off the lubricant with a soft cloth and a mild, non-abrasive cleaner.

⚠ WARNING: Do not plug in the power cord until the treadmill is completely assembled.

1. With the help of a second person, carefully raise the Uprights (110) to the position shown.

Refer to the inset drawing. Insert one of the Extension Legs (88) into the treadmill as shown. Make sure that the Thick Base Pad (90) is on the bottom. (Note: It may be helpful to tip the Uprights [110] forward as you insert the Extension Leg.) Insert the other Extension Leg (not shown) in the same way.

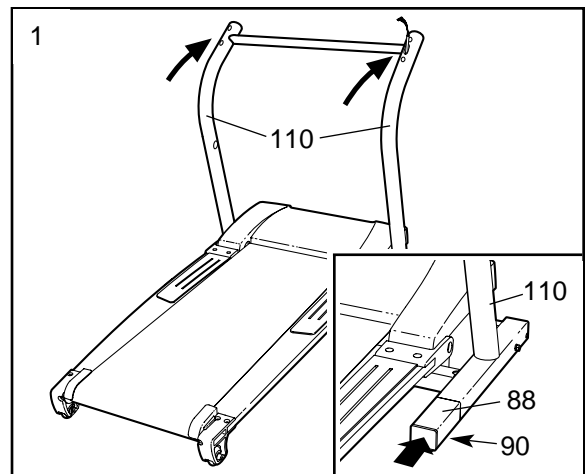

2. With the help of a second person, carefully tip the Uprights (110) down as shown. **Make sure that the Extension Legs (88) remain in the Uprights.**

Attach each Extension Leg (88) with two Base Screws (86) and a Base Pad (90) as shown.

With the help of a second person, carefully tip the Uprights (110) back to the vertical position.

Note: One replacement Base Pad (90) may be included.

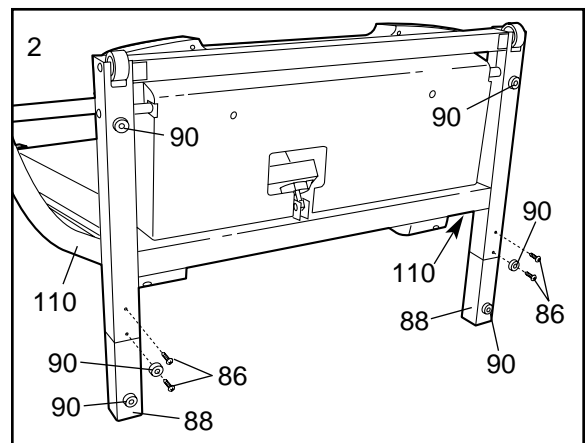

3. Refer to drawing 3a. Whilst another person holds the Handrails (89), thread Handrail Bolts (111) two to three turns into the two holes in each Handrail. Then, **remove the Handrail Bolts.**

Refer to drawing 3b. Pinch the tabs on the Grounding Bracket (115) so that the tabs will fit into the indicated hole in the left Upright (110). Then, insert the Grounding Bracket into the hole as far as possible.

Note: It may be helpful to set the Handrails (89) on the Uprights (110) and loosely thread a Handrail Bolt (111) into the left Upright and the left Handrail. Tip the Handrails, if necessary, to thread in the Handrail Bolt. Have another person support the Handrails as you complete the remaining steps.

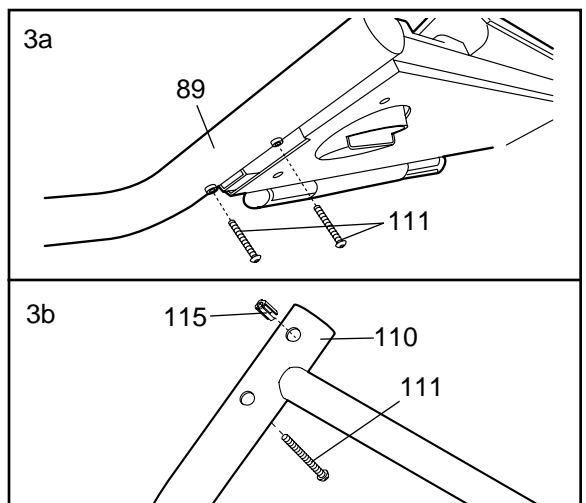

- Pull the Upright Wire Harness (101) up through a Handrail Spacer (114). Place the Handrail Spacer on the right Upright (110) as shown, with the cutout turned toward the treadmill (see inset drawing A).

Connect the Upright Wire Harness (101) to the wires extending from the Console Base (76). Insert the connectors and the Upright Wire Harness into the hole in the Console Base (see inset drawing B).

Set the Handrail (89) on the right Handrail Spacer (114), being careful not to pinch the Upright Wire Harness (101).

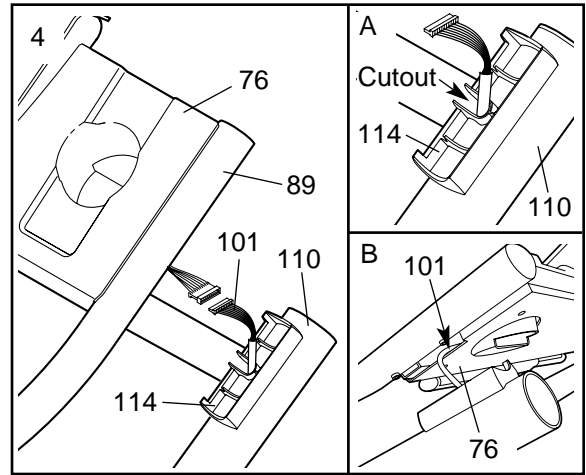

- Insert two Handrail Bolts (111) with Handrail Washers (112) and Handrail Bushings (113) into the right Upright (110) and the right Handrail Spacer (114). Turn the Handrail Bushings so they fit against the Upright with the thick sides of the Bushings toward the centre of the treadmill (refer to the inset drawing). Lift the right Handrail (89) slightly and align the Bolts with the holes in the Handrail. Loosely thread the Bolts into the Handrail. **Do not tighten the Bolts yet.**

Refer to the inset drawing. Remove the Handrail Bolt (111) used in step 4. Place the other Handrail Spacer (114) on the left Upright (110), with the cutout toward the treadmill. Reach inside the left Upright and spread the tabs on the Grounding Bracket (115) to allow a Bolt to pass through the Grounding Bracket. Attach the left Handrail (89) as described above. Make sure that the Handrail Bushings (113) are turned properly and that the Bolt goes through the Grounding Bracket. **Tighten all four Handrail Bolts.** Press an Upright Endcap (116) into each Upright.

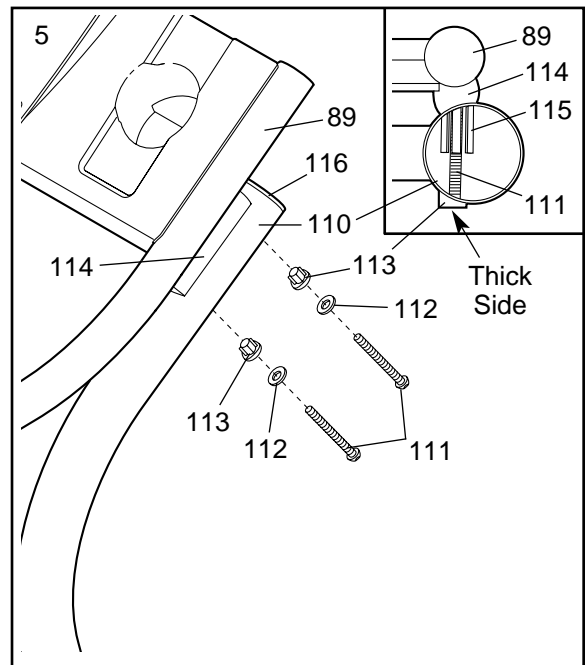

- Make sure that the Lock Knob Sleeve (106) is pressed into the left Upright (110).

Make sure that the Lock Pin Collar (105) and the Spring (104) are on the Lock Pin (102). Insert the Lock Pin into the Lock Knob Sleeve (106) and the left Upright (110). Next, press the Lock Knob Spacer (107) onto the Lock Pin. Tighten the Lock Knob (108) onto the Lock Pin.

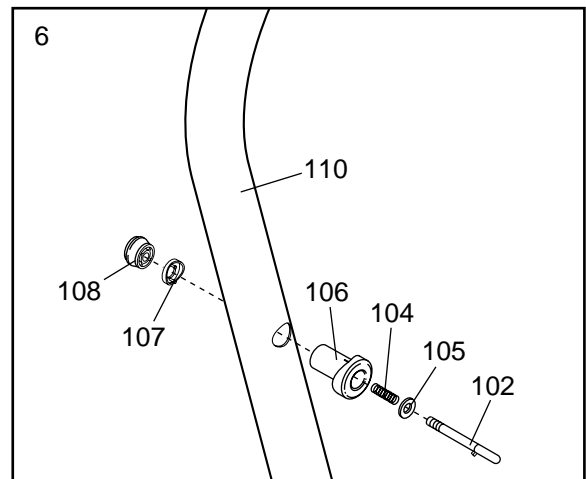

- Make sure that all parts are properly tightened before you use the treadmill.** Keep the included allen wrench in a secure place. The allen wrench is used to adjust the walking belt (see page 28). **To protect the floor or carpet from damage, place a mat under the treadmill.**

HOW TO USE THE CHEST PULSE SENSOR

HOW TO PUT ON THE CHEST PULSE SENSOR

Before you use the chest pulse sensor, please read all instructions on this page.

The chest pulse sensor consists of two components: the chest strap and the sensor unit.

If the chest strap is not connected to the sensor unit, refer to drawing 2. Insert one of the tabs on the chest strap through one end of the sensor unit. Make sure to press the end of the sensor unit under the buckle on the chest strap—the tab should be almost flush with the sensor unit.

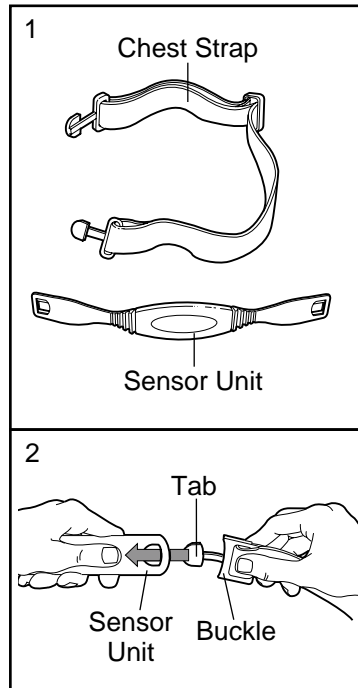

Next, wrap the chest pulse sensor around your chest and attach the other end of the chest strap to the sensor unit. Adjust the length of the chest strap, if necessary. The chest pulse sensor should be under your clothes, tight against your skin, and as high under the pectoral muscles or breasts as is comfortable. Make sure that the logo on the sensor unit is facing forward and is right-side-up.

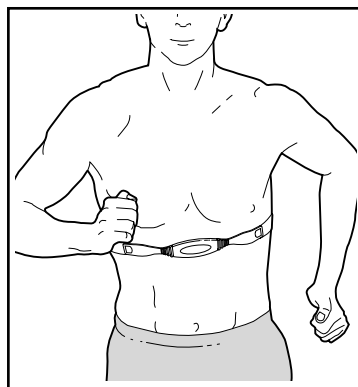

Pull the sensor unit away from your body a few inches and locate the two electrode areas on the inner side. The electrode areas are the areas covered by shallow ridges. Using saline solution such as saliva or contact lens solution, wet both electrode areas. Return the sensor unit to a position against your chest.

CHEST PULSE SENSOR CARE AND MAINTENANCE

- Thoroughly dry the chest pulse sensor after each use. The chest pulse sensor is activated when the electrode areas are wetted and the heart rate monitor is put on; the chest pulse sensor shuts off when it is removed and the electrode areas are dried. If the chest pulse sensor is not dried after each use, it may remain activated longer than necessary, draining the battery prematurely.
- Store the chest pulse sensor in a warm, dry place. Do not store the chest pulse sensor in a plastic bag or other container that may trap moisture.
- Do not expose the chest pulse sensor to direct sunlight for extended periods of time.
- Do not expose the chest pulse sensor to temperatures above 50° C (122° F) or below -10° C (14° F).
- Do not excessively bend or stretch the sensor unit when using or storing the chest pulse sensor.
- Clean the sensor unit periodically using a damp cloth; never use alcohol, abrasives, or chemicals. The chest strap may be hand washed and air dried.

CHEST PULSE SENSOR TROUBLESHOOTING

The instructions on the following pages explain how the chest pulse sensor is used with the console. If the letters “PLS” appear in the Heart Rate/Calories display, or if the displayed heart rate is excessively high or low, try the steps below.

- Make sure that you are wearing the chest pulse sensor as described at the left. If the chest pulse sensor does not function when positioned as described, move it slightly lower or higher on your chest.
- Use saline solution such as saliva or contact lens solution to wet the two electrode areas on the sensor unit. If heart rate readings do not appear until you begin perspiring, re-wet the electrode areas.
- As you walk or run on the treadmill, position yourself near the centre of the walking belt. **For the console to display heart rate readings, the user must be within arm’s length of the console.**

- The CR2032 battery may need to be replaced. Follow the steps below to replace the battery.

Locate the battery cover on the back of the sensor unit. Insert a coin into the slot in the cover and turn the cover counterclockwise to the “open” position. Remove the cover.

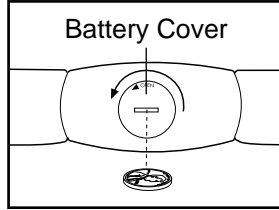

Next, remove the old battery from the sensor unit. Insert a new **CR 2032 battery**, making sure that the writing is on top. In addition, make sure that the rubber gasket is in place in the sensor unit. Replace the battery cover and turn it to the closed position.

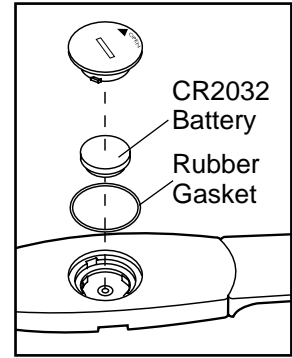

OPERATION AND ADJUSTMENT

THE PERFORMANT LUBE™ WALKING BELT

Your treadmill features a walking belt coated with PERFORMANT LUBE™, a high-performance lubricant. **IMPORTANT: Never apply silicone spray or other substances to the walking belt or the walking platform. Such substances will deteriorate the walking belt and cause excessive wear.**

HOW TO PLUG IN THE POWER CORD

This product must be earthed. If it should malfunction or break down, earthing provides a path of least resistance for electric current to reduce the risk of electric shock. This product is equipped with a cord having an equipment-earthing conductor and an earthing plug.

Two power cords are included. Select the one that will fit your outlet. Refer to drawing 1, and plug the indicated end of the power cord into the socket on the treadmill. Next, lift the indicated tab on the ferrite box and clamp the ferrite box around the power cord. The ferrite box should not be allowed to slide along the power cord. Fasten the included plastic tie just behind the ferrite box and cut off the excess plastic tie. Refer to drawing 2. Plug the power cord into an appropriate outlet that is properly installed and earthed in accordance with all local codes and ordinances. **Note: In Italy, an adaptor (not included) must be used between the power cord and the outlet. Important: The treadmill is not compatible with GFCI-equipped outlets.**

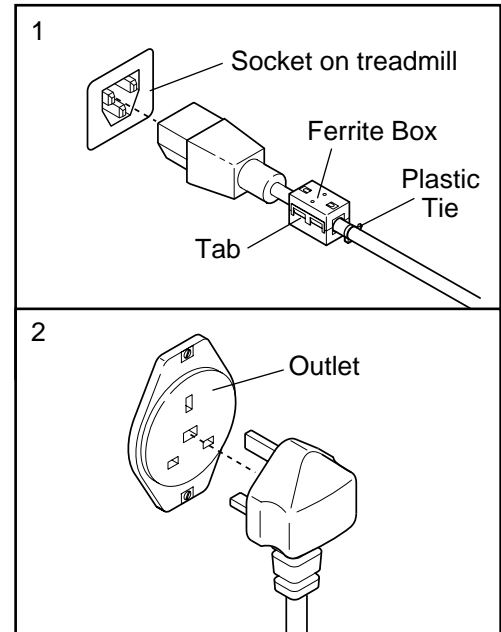

If the power cord is damaged, it must be replaced with a manufacturer-recommended power cord.

⚠ DANGER: Improper connection of the equipment-earthing conductor can result in an increased risk of electric shock. Check with a qualified electrician or serviceman if you are in doubt as to whether the product is properly earthed. Do not modify the plug provided with the product—if it will not fit the outlet, have a proper outlet installed by a qualified electrician.

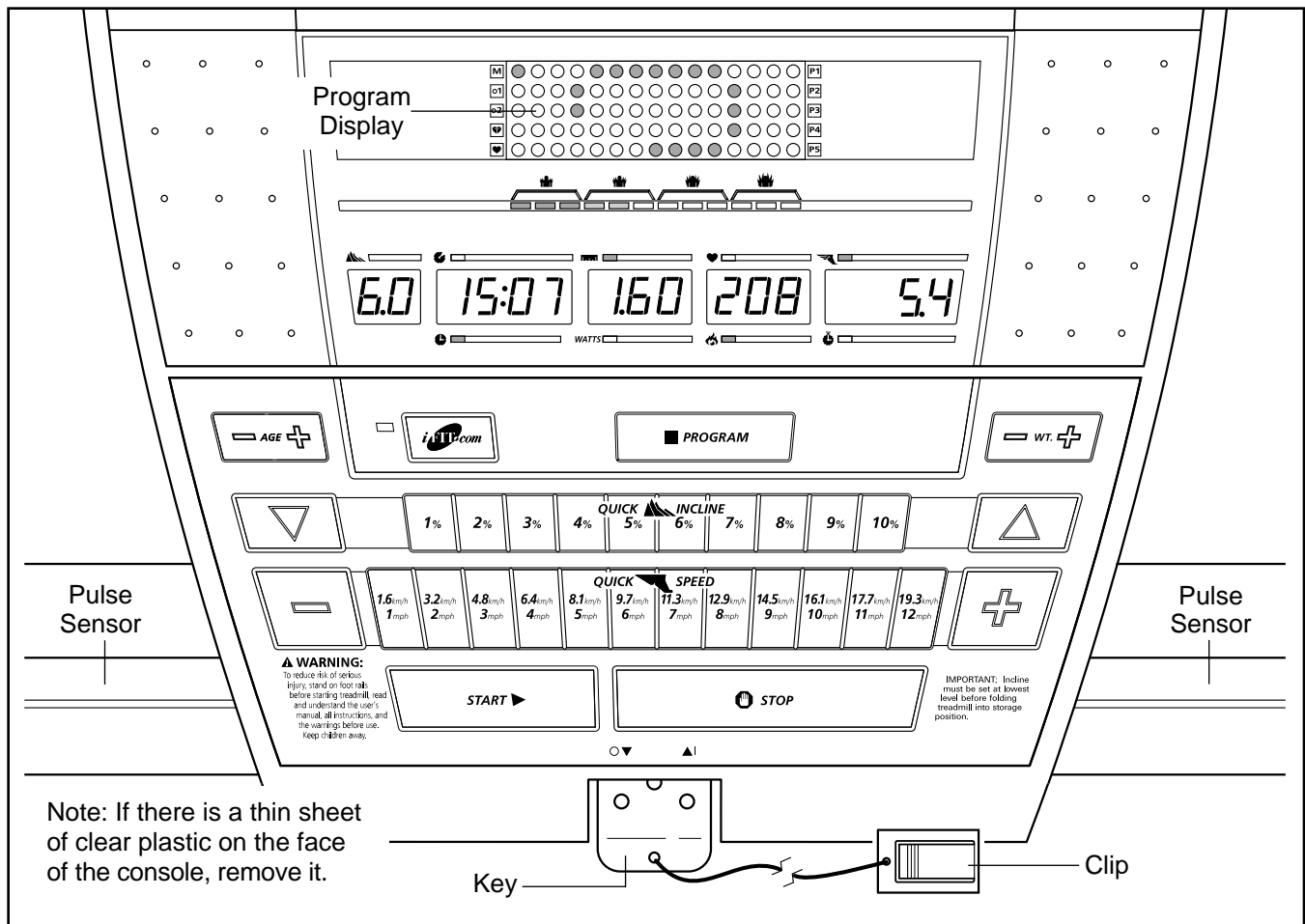

FEATURES OF THE CONSOLE

The advanced console offers an impressive array of features to help you get the most from your exercise. When the console is in the manual mode, the speed and incline of the treadmill can be changed with a touch of a button. As you exercise, the console will provide continuous exercise feedback. You can even measure your heart rate using the handgrip pulse sensor or the chest pulse sensor.

Five preset workout programs are also offered. Each program automatically controls the speed and incline of the treadmill to give you an effective workout. The included hand weights let you add upper-body exercise to your workouts as well. You can even create your own custom workout programs and store them in memory for future use.

In addition, the console offers a fitness test program that measures your relative fitness level and a pulse-driven program that automatically adjusts the speed and incline of the treadmill to keep your heart rate near a target level during your workout. Note: The fitness test program and the pulse-driven program require the use of the chest pulse sensor.

The console also features new iFIT.com interactive

technology. iFIT.com technology is like having a personal trainer right in your home. Using the included audio cable, you can connect the treadmill to your home stereo, portable stereo, or computer and play special iFIT.com CD programs (iFIT.com CD's are available separately). iFIT.com CD programs automatically control the speed and incline of the treadmill as a personal trainer guides you through every step of your workout. High-energy music provides added motivation. Each CD features two programs designed by certified personal trainers.

In addition, you can connect the treadmill to your VCR and TV and play iFIT.com video programs (videocassettes are available separately). Video programs offer the same benefits as iFIT.com CD programs, but add the excitement of working out with a class and an instructor—the hottest new trend at health clubs.

With the treadmill connected to your computer, you can also go to our Web site at www.iFIT.com and access basic programs, audio programs, and video programs directly from the internet. See www.iFIT.com for details.

For information about iFIT.com CD's or videocassettes, send an e-mail to workouts@iFIT.com.

! CAUTION: Before operating the console, read the following precautions.

- Do not stand on the walking belt when turning on the power.
- Always wear the clip (see the drawing below) whilst operating the treadmill.
- Adjust the speed in small increments to avoid sudden jumps in speed.
- The pulse sensors are not medical devices. Various factors, including the user's movement, may affect the accuracy of heart rate readings. The pulse sensors are intended only as an exercise aid in determining heart rate trends in general.
- Using hand weights and not holding the handrails may compromise your ability to maintain your balance. Hand weights should be used only by experienced users.
- To reduce the possibility of electric shock, keep the console dry. Avoid spilling liquids on the console and place only a sealed water bottle in the water bottle holder.

GETTING STARTED

1 Attach the clip to the waistband of your clothes.

Stand on the foot pads of the treadmill. Find the clip attached to the key and slide the clip onto the waistband of your clothes. Next, insert the key into the console. **Test the clip by carefully taking a few steps backward until the key is pulled from the console. If the key is not pulled from the console, adjust the position of the clip as needed.** Then, remove the key from the console.

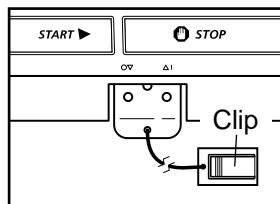

2 Plug in the power cord.

See HOW TO PLUG IN THE POWER CORD on page 9.

3 Move the on/off switch to the on position.

Locate the on/off switch on the treadmill near the power cord. Move the on/off switch to the on position.

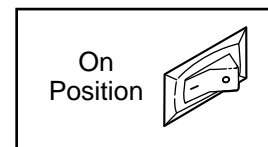

4 Insert the key fully into the console.

Stand on the foot pads of the treadmill. Make sure that the clip is securely attached to the waistband of your clothes. Next, insert the key into the console. After a moment, various displays and indicators on the console will light.

5 Enter your weight.

Although you can use the console without entering your weight, the console will display your calorie expenditure more accurately if you enter your weight.

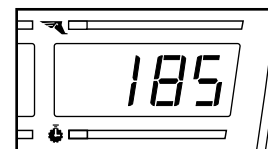

To enter your weight, press either of the Weight (WT.) buttons. The current weight setting will appear in the Speed/Pace display. Press the Weight buttons again to enter your weight. A few seconds after the buttons are pressed, the weight setting will disappear from the display. Your weight will then be saved in memory.

To use the manual mode of the console, follow the steps beginning on page 12. **To use a preset program**, see page 13. **To create and use a custom program**, see pages 15 and 16. **To use the fitness test program**, see page 17. **To use the pulse-driven program**, see page 18. **To use an iFIT.com CD or video program**, see page 22. **To use an iFIT.com program directly from our Web site**, see page 24.

HOW TO USE THE MANUAL MODE

1 Insert the key fully into the console.

See GETTING STARTED on page 11.

2 Select the manual mode.

When the key is inserted, the manual mode will be selected and the M indicator will light. If a program has been selected, press the PROGRAM button repeatedly to select the manual mode.

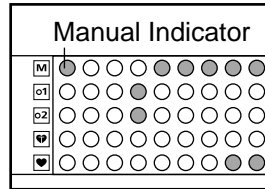

3 Press the START button or the Speed + button to start the walking belt.

A moment after the button is pressed, the walking belt will begin to move at 1 mph. Hold the handrails and begin walking. As you exercise, change the speed of the walking belt as desired by pressing the Speed + and - buttons. Each time a button is pressed, the speed setting will change by 0.1 mph; if a button is held down, the speed setting will change in increments of 0.5 mph. To change the speed setting quickly, press the QUICK SPEED buttons. The speed range is 0.5 mph to 12 mph. Note: After the buttons are pressed, it may take a moment for the treadmill to reach the selected speed setting.

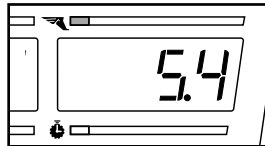

To stop the walking belt, press the STOP button. The Time display will begin to flash. To restart the walking belt, press the START button or the Speed + button.

During the first few minutes that you use the treadmill, inspect the alignment of the walking belt, and align the walking belt if necessary (see page 28).

4 Change the incline of the treadmill as desired.

To change the incline of the treadmill, press the INCLINE buttons. Each time a button is pressed, the incline will change by 0.5%. To change the incline setting quickly, press the QUICK INCLINE buttons. The incline range is 0% to 10%. Note: After the buttons are pressed, it may take a moment for the treadmill to reach the selected incline setting.

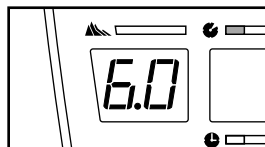

5 Follow your progress with the LED track and the displays.

The LED track—When the manual mode or the iFIT.com mode is selected, the program display will show an LED track representing 1/4 mile. As you exercise, the indicators around the track will light in sequence until you have walked or run 1/4 mile. A new lap will then begin.

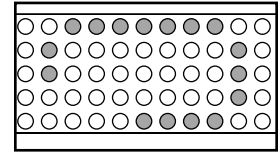

The Training Zone display—As you exercise, the Training Zone display will show the approximate intensity level of your exercise. For example, if three to six indicators in the display are lit, your intensity level is ideal for fat burning.

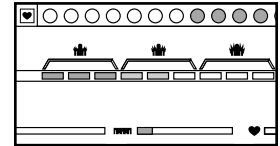

Incline display—This display shows the incline level of the treadmill.

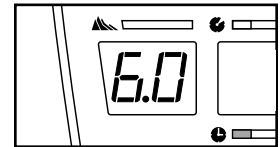

Time display—When the manual mode or the iFIT.com mode is selected, this display will show the elapsed time. When a preset program or a custom program is selected, the display will show the time remaining in the program and the time remaining in the current segment of the program. The display will change from one number to the other every few seconds, as shown by the indicators around the display.



Distance/Watts display—This display shows the distance that you have walked and your power output in watts. The display will change from one number to the other every few seconds.

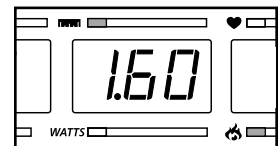

Heart Rate/Calories display—This display shows the approximate number of calories you have burned. When the the handgrip pulse sensor or the chest pulse sensor (see page 8) is used, the display will also show your heart rate.



Speed/Pace display—

This display shows the speed of the walking belt and your current pace (pace is measured in minutes per mile). The display will change from one number to the other every few seconds, as shown by the indicators around the display.

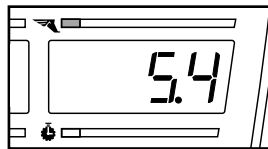

Note: The console can display speed and distance in either miles or kilometres. To find which unit of measurement is selected, hold down the STOP button whilst inserting the key into the console. An E, for English miles, or an M, for metric kilometres, will appear in the Speed/Pace display. Press the Speed + button to change the unit of measurement. When the desired unit of measurement is selected, remove the key and then reinsert it. Note: For simplicity, all instructions in this manual refer to miles.

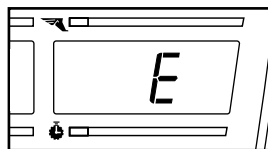

To reset the displays, press the STOP button, remove the key, and then reinsert the key.

6 Measure your heart rate, if desired.

You can measure your heart rate using either the handgrip pulse sensor or the chest pulse sensor. Follow the instructions below to use the handgrip pulse sensor.

Stand on the foot pads and place your hands on the metal contacts on the handrail. Your palms must be resting on the upper contacts, and your fingers must be touching the lower contacts—**avoid moving your hands**.

When your pulse is detected, the Heart Rate indicator will flash, and then your heart rate will be shown. **For the most accurate heart rate reading, continue to hold the contacts for about 15 seconds.**

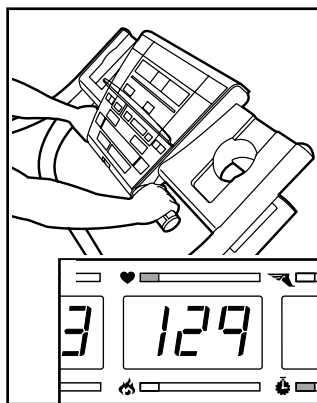

7 When you are finished exercising, stop the walking belt and remove the key.

Step onto the foot pads, press the Stop button, and adjust the incline of the treadmill to the lowest level. **The incline must be at the lowest level when the treadmill is raised to the storage position or the treadmill will be damaged.** Next, remove the key from the console and put it in a secure place. **Note: If the displays and indicators on the console remain lit after the key is removed, the console is in the “demo” mode. Refer to page 25 and turn off the demo mode.**

When you are finished using the treadmill, move the on/off switch near the power cord to the off position and unplug the power cord.

HOW TO USE PRESET PROGRAMS

1 Insert the key fully into the console.

See GETTING STARTED on page 11.

2 Select one of the five preset programs.

When the key is inserted, the manual mode will be selected. To select one of the preset programs, press the PROGRAM button repeatedly until the P1, P2, P3, P4, or P5 indicator lights.

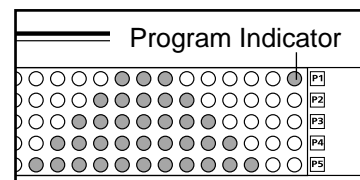

When you select a preset program, the program display will show a simplified profile of the program you have selected. For example, the profile above shows that the intensity of the selected program will increase during the first half of the program, and then decrease during the last half of the program. The Time display will show how long the program will last.

3 Press the Start button or the Speed + button to start the program.

A moment after the button is pressed, the treadmill will automatically adjust to the first speed and incline settings for the program. Hold the handrails and begin walking.

Each program is divided into several time segments of different lengths. The Time display shows both the time remaining in the program and the time remaining in the current segment. One speed setting and one incline setting are programmed for each segment. The speed setting for the first segment will be shown in the flashing Current Segment column of the program display. (The incline settings are not shown in the program display.) The speed settings for the next twelve segments will be shown in the twelve columns to the right.

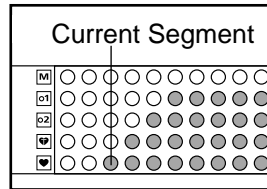

When only three seconds remain in the first segment of the program, both the Current Segment column and the column to the right will flash and a tone will sound. In addition, if the speed and/or incline of the treadmill is about to change, the Speed/Pace display and/or the Incline display will flash to alert you, and three tones will sound. When the first segment is completed, all speed settings will move one column to the left. The speed setting for the second segment will then be shown in the flashing Current Segment column and the treadmill will automatically adjust to the speed and incline settings for the second segment.

The program will continue in this way until the speed setting for the last segment is shown in the Current Segment column and no time remains in the Time display. The walking belt will then slow to a stop.

Note: Each time a segment ends and the speed settings move to the left, if all of the indicators in the Current Segment column are lit, the speed settings may move downward so that only the highest indicators in the columns will appear in the program display. When the speed settings move to the left again and some indicators in the Current Segment column are dark, the speed settings will move back up.

If the speed or incline setting for the current segment is too high or too low, you can manually

override the setting by pressing the Speed or Incline buttons on the console. Every few times one of the Speed buttons is pressed, an additional indicator will light or darken in the Current Segment column. If any of the columns to the right of the Current Segment column have the same number of lit indicators as the Current Segment column, an additional indicator may light or darken in those columns as well. Note: If you manually adjust the speed setting so that all of the indicators in the Current Segment column are lit, the speed settings in the program display will not move downward as described above. **Note: If you manually override the speed or incline setting for the current segment, when the segment ends the treadmill will automatically adjust to the speed and incline settings for the next segment.**

To stop the program temporarily, press the STOP button. The Time display will begin to flash. To restart the program, press the START button or the Speed + button. To end the program, press the STOP button, remove the key, and then reinsert the key.

4 Follow your progress with the displays.

See step 5 on page 12.

5 Measure your heart rate, if desired.

See step 6 on page 13.

6 When the program has ended, remove the key.

Step onto the foot pads and make sure that the incline of the treadmill is at the lowest level. **The incline must be at the lowest level when the treadmill is raised to the storage position.** Next, remove the key from the console and put it in a secure place. **Note: If the displays and indicators on the console remain lit after the key is removed, the console is in the “demo” mode. See page 25 and turn off the demo mode.**

When you are finished using the treadmill, move the on/off switch near the power cord to the off position and unplug the power cord.

HOW TO CREATE CUSTOM PROGRAMS

1 Insert the key fully into the console.

See GETTING STARTED on page 11.

2 Select one of the custom programs.

When the key is inserted, the manual mode will be selected. To select one of the custom programs, press the PROGRAM button repeatedly until the o1 or o2 indicator lights.

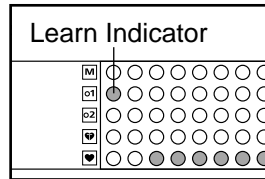

Note: If the custom program has not yet been defined, three columns of indicators will be lit in the program display. If more than three columns of indicators are lit, refer to HOW TO USE CUSTOM PROGRAMS on page 16.

3 Press the START button or the Speed + button and program the desired speed and incline settings.

A moment after the button is pressed, the walking belt will begin to move. Hold the handrails and begin walking.

Refer to the program display. Each custom program is divided into one-minute segments. One speed setting and one incline setting can be programmed for each segment. The speed setting for the first segment will be shown in the flashing Current Segment column of the program display. (The incline settings are not shown in the program display.) To program a speed setting and an incline setting for the first segment, simply

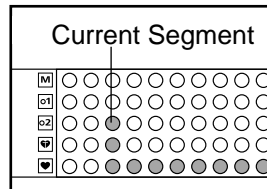

adjust the speed and incline of the treadmill to the desired levels by pressing the Speed and Incline buttons. Every few times one of the Speed buttons is pressed, an additional indicator will light or darken in the Current Segment column.

When the first segment of the program is completed, the current speed setting and the current incline setting will be stored in memory. The three columns of indicators will then move one column to the left, and the speed setting for the second segment will be shown in the flashing Current Segment column. Program a speed setting and an incline setting for the second segment as described above. Note: After the third segment is completed, the columns of indicators in the program display will no longer move to the left. Instead, each time a segment is completed, the flashing Current Segment column will move one column to the right. If the Current Segment column reaches the right side of the program display, when the current segment is completed all columns of indicators in the program display will move three columns to the left.

Continue programming speed and incline settings for as many segments as desired; custom programs can have up to forty segments. When you are finished with your workout, press the STOP button twice. The speed and incline settings that you programmed and the number of segments that you programmed will then be saved in memory.

4 Follow your progress with the displays.

See step 5 on page 12.

5 When the program has ended, remove the key.

See step 6 on page 14.

HOW TO USE CUSTOM PROGRAMS

1 Insert the key fully into the console.

See GETTING STARTED on page 11.

2 Select one of the custom programs.

When the key is inserted, the manual mode will be selected. To select one of the custom programs, press the PROGRAM button repeatedly until the o1 or o2 indicator lights.

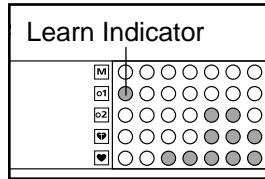

When a custom program is selected, the program display will show a simplified profile of the program. The Time display will show how long the program will last. **Note: If only three columns of indicators are lit in the program display, refer to HOW TO CREATE CUSTOM PROGRAMS on page 15.**

3 Press the START button or the Speed + button to start the program.

A moment after the button is pressed, the treadmill will automatically adjust to the first speed and incline settings for the program. Hold the handrails and begin walking.

Each program is divided into several one-minute segments. The Time display shows both the time remaining in the program and the time remaining in the current segment. One speed setting and one incline setting are programmed for each segment. The speed setting for the first segment will be shown in the flashing Current Segment column of the program display. (The incline settings are not shown in the program display.)

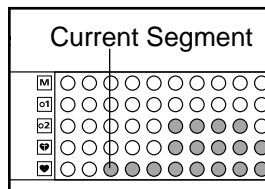

The speed settings for the next twelve segments will be shown in the twelve columns to the right.

When only three seconds remain in the first segment of the program, both the Current Segment column and the column to the right will flash and a tone will sound. In addition, if the speed and/or incline of the treadmill is about to change, the Speed/Pace display and/or the Incline display will flash to alert you, and three tones will sound.

When the first segment is completed, all speed settings will move one column to the left. The speed setting for the second segment will then be shown in the flashing Current Segment column and the treadmill will automatically adjust to the speed and incline settings for the second segment.

The program will continue until the speed setting for the last segment is shown in the Current Segment column and no time remains in the Time display. The walking belt will then slow to a stop.

If desired, you can redefine to the program whilst using the program. **To change the speed or incline setting during the current segment**, simply press the Speed or Incline buttons. When the current segment is completed, the new setting will be saved in memory. **To increase the length of the program**, first wait until the program is completed. Then, press the START button and program speed and incline settings for as many additional segments as desired. (Note: Whilst you are adding segments to the program, the speed settings in the program display will not move to the left. Instead, each time a segment is completed, the flashing Current Segment column will move one column to the right. If the Current Segment column reaches the right side of the program display, when the current segment is completed all columns of indicators in the program display will move three columns to the left.) When you have added as many segments as desired, press the STOP button twice. **To decrease the length of the program**, press the STOP button twice at any time before the program is completed.

To stop the program temporarily, press the STOP button. All displays will pause and the Time display will begin to flash. To restart the program, press the START button or the Speed + button. To end the program, press the STOP button, remove the key, and then reinsert the key.

4 Follow your progress with the displays.

See step 5 on page 12.

5 Measure your heart rate, if desired.

See step 6 on page 13.

6 When the program has ended, remove the key.

See step 6 on page 14.

HOW TO USE THE FITNESS TEST PROGRAM

The fitness test program is designed to measure your relative fitness level. For the best results, the fitness test program should be used at a time when your energy level is high; the fitness test program should not be used if you have already exercised during the day.

Note: You must wear the chest pulse sensor to use the fitness test program.

Follow the steps below to use the fitness test program.

1 Put on the chest pulse sensor.

Refer to the instructions on page 8 and put on the chest pulse sensor. Note: The fitness test program will automatically stop if your heart rate is not detected 4 minutes after the program is started.

2 Insert the key fully into the console.

See GETTING STARTED on page 11.

3 Select the fitness test program.

When the key is inserted, the manual mode will be selected. To select the fitness test program, press the PROGRAM button repeatedly until the Fitness Test indicator lights. When you select the fitness test program, the program display will show a simplified profile of the program.

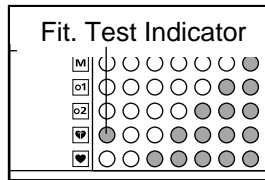

4 Enter your age.

When the fitness test program is selected, an age setting will flash in the Incline display and the letters "AGE" will appear in the Time display. You must enter your age to use the fitness test program. If you have already entered your age, go to step 5. If you have not entered your age, press the AGE buttons to enter your age. Four seconds after the buttons are pressed, the age setting will disappear from the display. Your age will then be saved in memory.

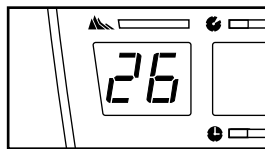

5 Press the START button or the Speed + button to start the program.

When the button is pressed, the Distance/Watts display will show an "L 1" (level 1), indicating that the first 4-minute segment of the fitness test program has begun. The incline of the treadmill will automatically adjust to 3% and the walking belt will begin to move at 1.5 mph. Hold the handrails and begin walking.

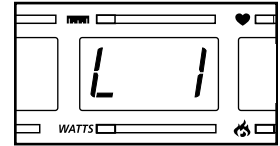

The fitness test program consists of seven, 4-minute segments and is followed by a 2-minute cool-down segment. One speed setting and one incline setting are programmed for each segment. The speed setting for the first segment will be shown in the flashing Current Segment column of the program display.

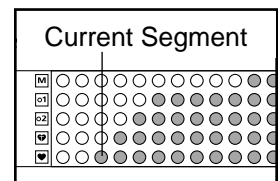

(The incline settings are not shown in the program display.) The speed settings for the remaining seven segments will be shown in the seven columns to the right.

When the first 4-minute segment of the fitness test program is completed, all speed settings will move one column to the left and the Distance/Watts display will show an "L 2," indicating that the second 4-minute segment has begun. The incline will then adjust to 4% and the speed will increase to 2.5 mph. When the second 4-minute segment is completed, the speed settings will again move one column to the left and the Distance/Watts display will show an "L 3." The incline will remain the same, but the speed will then increase to 3.3 mph. At the beginning of each 4-minute segment, the speed and/or incline of the treadmill will automatically increase. The fitness test program will continue in this way until your heart rate reaches 70% of your estimated maximum heart rate, and the current 4-minute segment is completed. The fitness test program will then be completed, regardless of how many segments remain.

When the fitness test program is completed, the letter "C" will appear in the Distance/Watts display, indicating that the 2-minute cool-down segment has begun. The incline will then adjust to 1% and the speed will decrease to 1.2 mph.

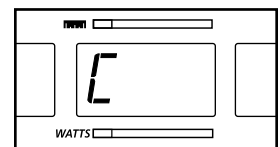

When the cool-down segment is completed, the walking belt will slow to a stop. After the fitness test program is completed, your fitness level will be shown in the Time display. There are ten fitness levels—fitness level 10 (FL:10) is the highest. Remember, the fitness program is intended only to indicate your relative fitness level.

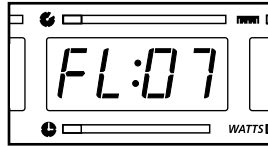

Note: The Speed and Incline buttons will not function whilst the fitness test program is selected. If your pulse is not detected during the program, the letters “PLS” will flash in the Heart Rate/Calories display. If your pulse is not detected during the last thirty seconds of any 4-minute segment (after 4 minutes, after 8 minutes, etc.), the fitness test program will end and the Time display will show a fitness level of 0 (FL: 0).

The fitness test program cannot be stopped temporarily and then restarted. However, the program can be stopped at any time with the STOP button. The Time display will then show an estimated fitness level.

- 6** When the program has ended, remove the key.
See step 6 on page 14.

HOW TO USE THE PULSE-DRIVEN PROGRAM

The pulse-driven program automatically adjusts the speed and incline of the treadmill to keep your heart rate near a target level during your workout. **Note: You must wear the chest pulse sensor to use the pulse-driven program.**

⚠ CAUTION: If you have heart problems, or if you are over 60 years of age and have been inactive, do not use the pulse-driven program. If you are taking medication regularly, consult your physician to find whether the medication will affect your exercise heart rate.

Follow the steps below to use the pulse-driven program.

- 1** Put on the chest pulse sensor.

To put on the chest pulse sensor, refer to page 8.

- 2** Insert the key fully into the console.

See GETTING STARTED on page 11.

- 3** Select the pulse-driven program.

When the key is inserted, the manual mode will be selected. To select the pulse-driven program, press the PROGRAM button repeatedly until the Pulse Driven indicator lights. When the pulse-driven program is selected, the program display will show a simplified profile of the program.

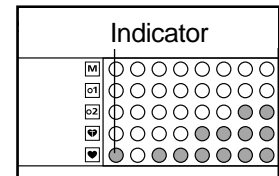

- 4** Enter your age.

When the pulse-driven program is selected, an age setting will flash in the Incline display and the letters “AGE” will appear in the Time display.

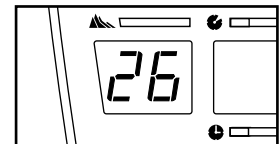

You must enter your age to use the pulse-driven program. If you have already entered your age, go to step 5. If you have not entered your age, press the AGE buttons to enter your age. A few seconds after the buttons are pressed, the age setting will disappear from the display. Your age will then be saved in memory.

5 Press the START button or the Speed + button to start the program.

A moment after the button is pressed, the treadmill will automatically adjust to the first speed and incline settings for the program. Hold the handrails and begin walking.

Each program is divided into several time segments of different lengths. The Time display will show both the time remaining in the program and the time remaining in the current segment. One target heart rate setting

is programmed for each segment. The heart rate setting for the first segment will be shown in the flashing Current

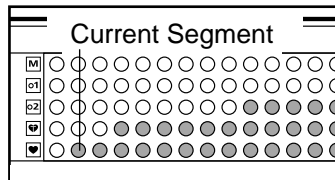

Segment column of the program display. The heart rate settings for the next twelve segments will be shown in the twelve columns to the right.

When only three seconds remain in the first segment of the program, both the Current Segment column and the column to the right will flash, a series of tones will sound, and the Speed/Pace display and the Incline display will flash. When the first segment is completed, all heart rate settings will move one column to the left. The heart rate setting for the second segment will then be shown in the flashing Current Segment column, and the speed and/or incline of the treadmill will change, if needed, to bring your heart rate closer to the heart rate setting for the second segment.

The program will continue until no time remains in the Time display. The walking belt will then slow to a stop.

If the speed or incline setting for the current segment is too high or too low, you can adjust the setting with the Speed or Incline buttons. However, if you decrease the speed, the incline will automatically increase; if you increase the speed, the incline will decrease. If you increase the incline, the speed will decrease; if you decrease the incline, the speed will increase. The treadmill will always attempt to keep your heart rate near the target heart rate setting for the current segment. Note: When the incline reaches the lowest setting, the speed cannot be increased any further. When the incline reaches the highest setting, the speed cannot be decreased any further.

If your heart rate is not detected during the program, the speed and incline of the treadmill may automatically decrease until your heart rate is detected. If this occurs, refer to the instructions on page 8.

To stop the program, press the STOP button. The Time display will begin to flash. The pulse-driven program should not be stopped temporarily and then restarted. To use the pulse-driven program again, reselect the program and start it at the beginning.

6 Follow your progress with the displays.

See step 5 on page 12.

7 When the program has ended, remove the key.

See step 6 on page 14.

HOW TO CONNECT THE TREADMILL TO YOUR CD PLAYER, VCR, OR COMPUTER

To use **iFIT.com CD's**, the treadmill must be connected to your portable CD player, portable stereo, home stereo, or computer with CD player. See pages 20 and 21 for connecting instructions. **To use iFIT.com videocassettes**, the treadmill must be connected to your VCR. See page 22 for connecting instructions. **To use iFIT.com programs directly from our Web site**, the treadmill must be connected to your home computer. See page 21 for connecting instructions.

HOW TO CONNECT YOUR PORTABLE CD PLAYER

Note: If your CD player has separate **LINE OUT** and **PHONES** jacks, see instruction A below. If your CD player has only one jack, see instruction B.

- A. Plug one end of the audio cable into the jack on the front of the treadmill near the power cord. Plug the other end of the cable into the **LINE OUT** jack on your CD player. Plug your headphones into the **PHONES** jack.

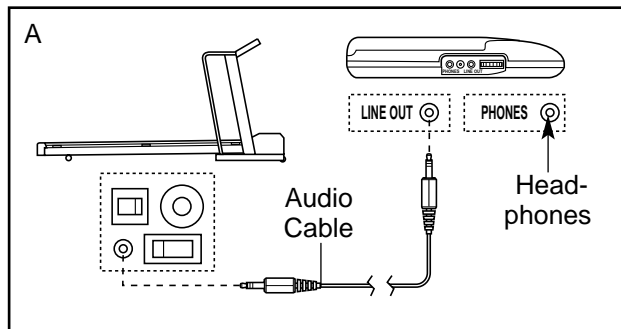

- B. Plug one end of the audio cable into the jack on the front of the treadmill near the power cord. Plug the other end of the cable into the splitter. Plug the splitter into the **PHONES** jack on your CD player. Plug your headphones into the other side of the splitter.

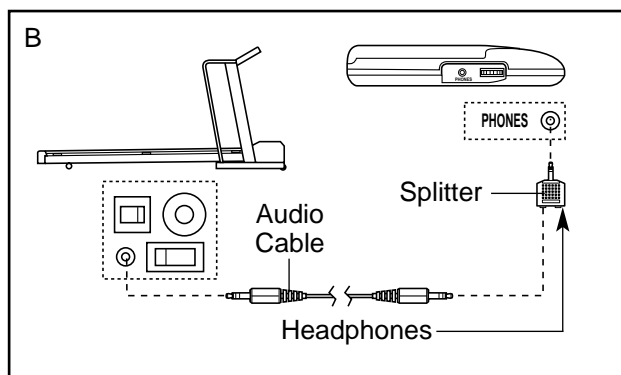

HOW TO CONNECT YOUR PORTABLE STEREO

Note: If your stereo has an **RCA-type AUDIO OUT** jack, see instruction A below. If your stereo has a **3.5mm LINE OUT** jack, see instruction B. If your stereo has only a **PHONES** jack, see instruction C.

- A. Plug one end of the audio cable into the jack on the front of the treadmill near the power cord. Plug the other end of the cable into the adaptor. Plug the adaptor into an **AUDIO OUT** jack on your stereo.

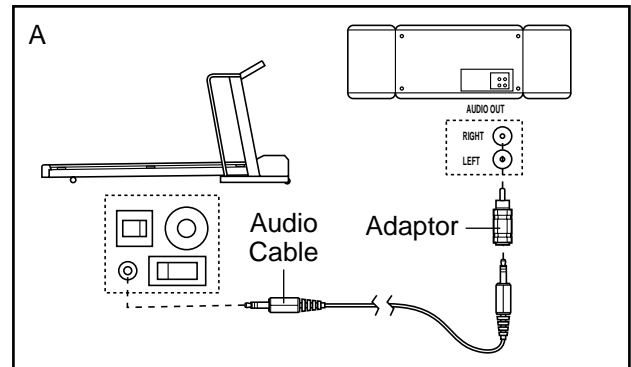

- B. Plug one end of the audio cable into the jack on the front of the treadmill near the power cord. Plug the other end of the cable into the **LINE OUT** jack on your stereo.

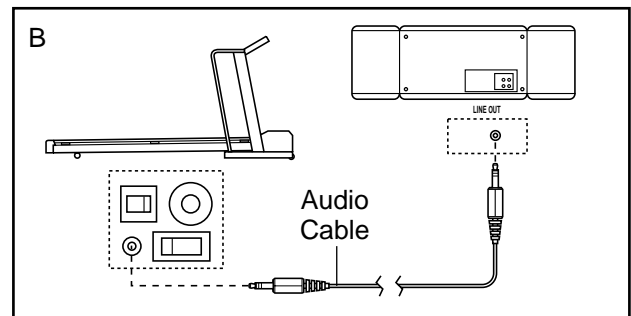

- C. Plug one end of the audio cable into the jack on the front of the treadmill near the power cord. Plug the other end of the cable into the splitter. Plug the splitter into the **PHONES** jack on your stereo. Plug your headphones into the other side of the splitter.

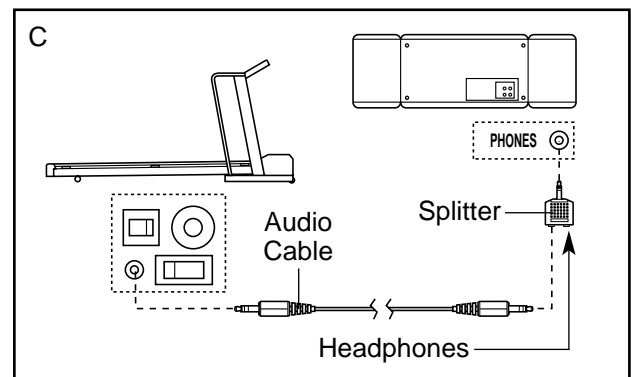

HOW TO CONNECT YOUR HOME STEREO

Note: If your stereo has an unused **LINE OUT** jack, see instruction **A** below. If the **LINE OUT** jack is being used, see instruction **B**.

- A. Plug one end of the audio cable into the jack on the front of the treadmill near the power cord. Plug the other end of the cable into the adaptor. Plug the adaptor into the **LINE OUT** jack on your stereo.

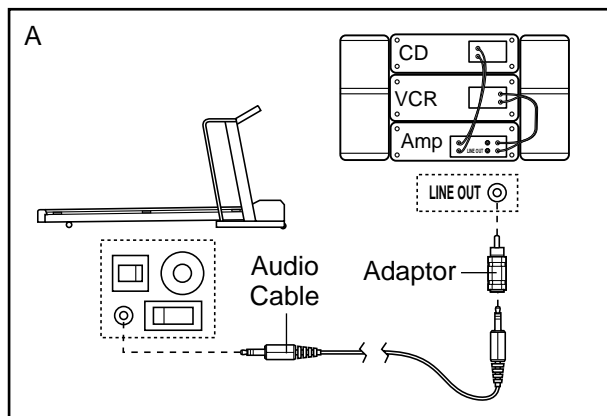

- B. Plug one end of the audio cable into the jack on the front of the treadmill near the power cord. Plug the other end of the cable into the adaptor. Plug the adaptor into an **RCA Y-adaptor** (available at electronics stores). Next, remove the wire that is currently plugged into the **LINE OUT** jack on your stereo and plug the wire into the unused side of the **Y-adaptor**. Plug the **Y-adaptor** into the **LINE OUT** jack on your stereo.

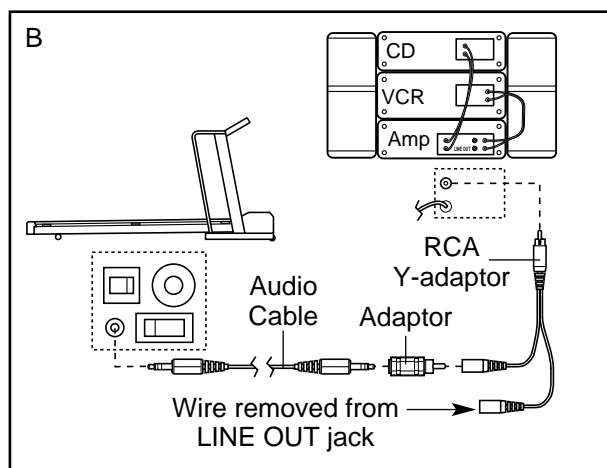

HOW TO CONNECT YOUR COMPUTER

Note: If your computer has a **3.5mm LINE OUT** jack, see instruction **A**. If your computer has only a **PHONES** jack, see instruction **B**.

- A. Plug one end of the audio cable into the jack on the front of the treadmill near the power cord. Plug the other end of the cable into the **LINE OUT** jack on your computer.

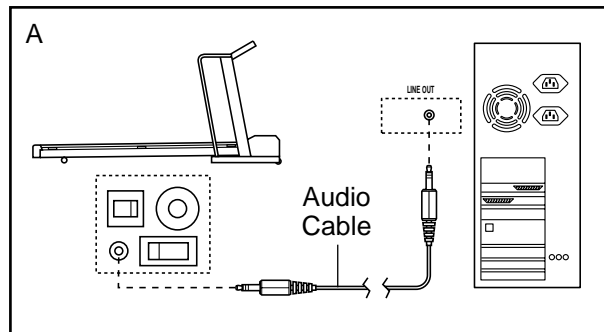

- B. Plug one end of the audio cable into the jack on the front of the treadmill near the power cord. Plug the other end of the cable into the splitter. Plug the splitter into the **PHONES** jack on your computer. Plug your headphones or speakers into the other side of the splitter.

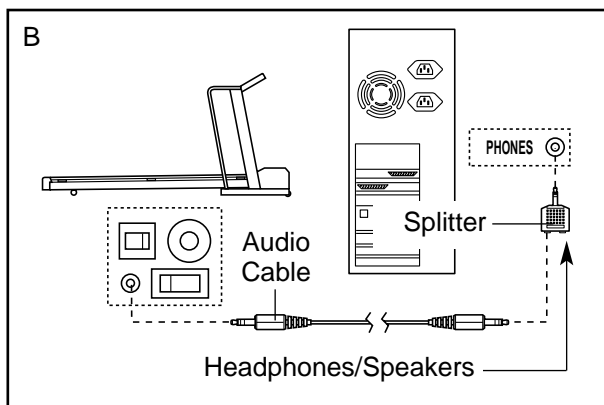

EXPLODED DRAWING—Model No. NETL15520

R0802A

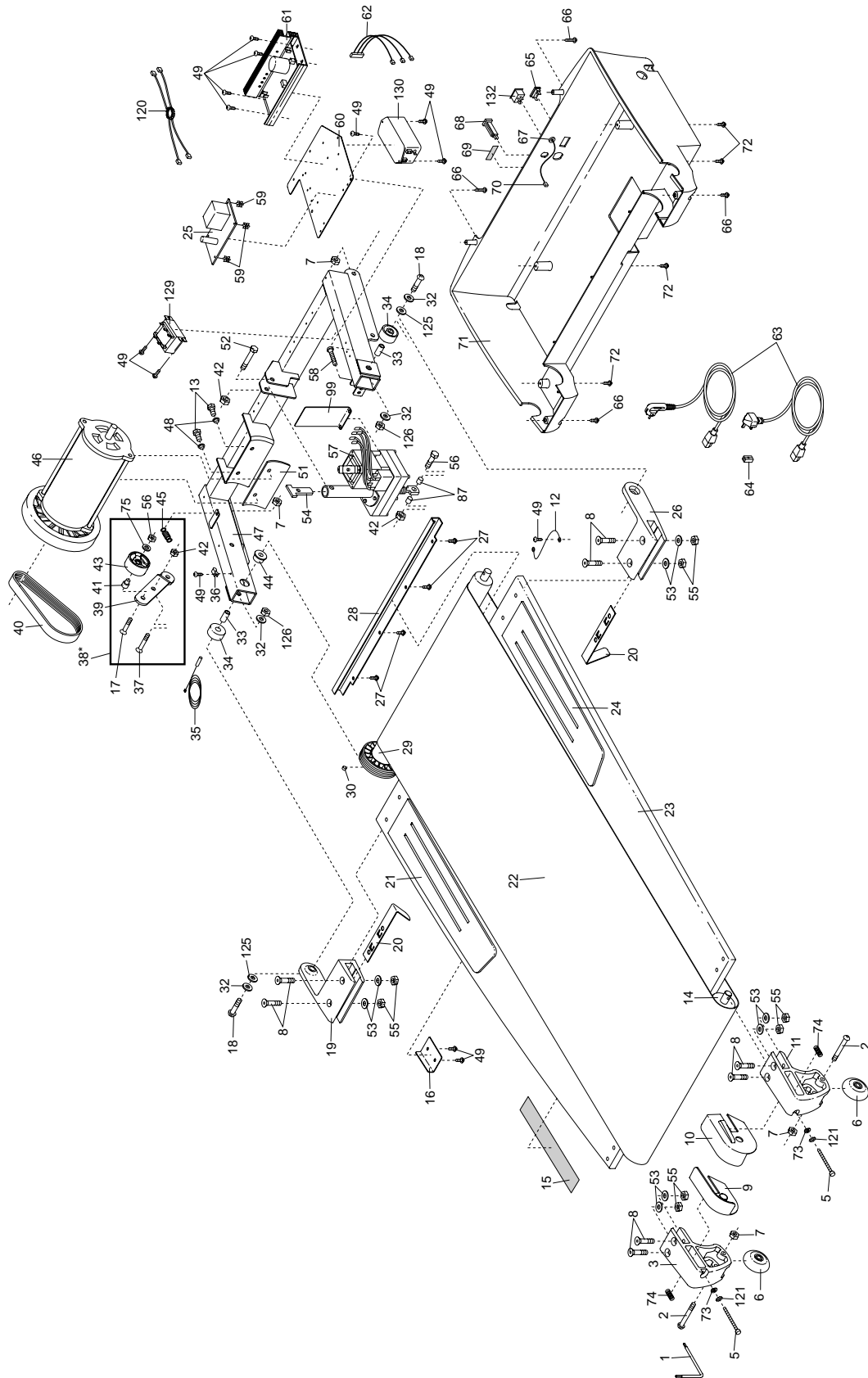

If the speed or incline settings are too high or too low, you can manually override the settings at any time by pressing the Speed or Incline buttons on the console. However, **when the next “chirp” is heard, the speed and/or incline will change to the next settings of the CD or video program.**

To stop the walking belt at any time, press the STOP button on the console. The Time display will begin to flash. To restart the program, press the START button or the Speed + button. After a moment, the walking belt will begin to move at 1.0 mph. **When the next “chirp” is heard, the speed and incline will change to the next settings of the CD or video program.**

When the CD or video program is completed, the walking belt will stop and the Time display will begin to flash. Note: To use another CD or video program, press the STOP button or remove the key and go to step 1 on page 22.

Note: If the speed or incline of the treadmill does not change when a “chirp” is heard:

- **Make sure that the iFIT.com indicator is lit and that the Time display is not flashing. If the Time display is flashing, press the START button or the Speed + button on the console.**
- **Adjust the volume of your CD player or VCR. If the volume is too high or too low, the console may not detect the program signals.**

- **Make sure that the audio cable is properly connected, that it is fully plugged in, and that it is not wrapped around a power cord.**
- **If you are using your portable CD player and the CD skips, set the CD player on the floor or another flat surface instead of on the console.**
- **See the instructions near the bottom of page 28.**

5 Follow your progress with the LED track and the displays.

See step 5 on page 12.

6 Measure your heart rate, if desired.

See step 6 on page 13.

7 When the program is completed, remove the key.

See step 6 on page 14.

CAUTION: Always remove iFIT.com CD's and videocassettes from your CD player or VCR when you are finished using them.

HOW TO USE PROGRAMS DIRECTLY FROM OUR WEB SITE

Our Web site at www.iFIT.com allows you to access basic programs, audio programs, and video programs directly from the internet. See www.iFIT.com for details.

To use programs from our Web site, the treadmill must be connected to your home computer. See HOW TO CONNECT YOUR COMPUTER on page 21. In addition, you must have an internet connection and an internet service provider. A list of specific system requirements will be found on our Web site.

Follow the steps below to use a program from our Web site.

1 Insert the key fully into the console.

See GETTING STARTED on page 11.

2 Select the iFIT.com mode.

When the key is inserted, the manual mode will be selected. To use a program from our Web site, press the iFIT.com button or press the PROGRAM button repeatedly until the indicator beside the iFIT.com button lights.

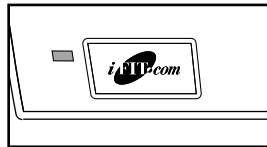

3 Go to your computer and start an internet connection.

4 Start your web browser, if necessary, and go to our Web site at www.iFIT.com.

5 Follow the desired links on our Web site to select a program.

Read and follow the on-line instructions for using a program.

6 Follow the on-line instructions to start the program.

When you start the program, an on-screen countdown will begin.

7 Return to the treadmill and stand on the foot pads. Find the clip attached to the key and slide the clip onto the waistband of your clothes.

When the on-screen countdown ends, the program will begin and the walking belt will begin to move. Hold the handrails, step onto the walking belt, and begin walking. During the program, an electronic “chirping” sound will alert you when the speed and/or incline of the treadmill is about to change. **CAUTION: Always listen for the “chirp” and be prepared for speed and/or incline changes.**

If the speed or incline settings are too high or too low, you can manually override the settings at any time by pressing the Speed or Incline buttons on the console. **However, when the next “chirp” is heard, the speed and/or incline will change to the next settings of the program.**

To stop the walking belt at any time, press the STOP button on the console. The Time display will begin to flash. To restart the program, press the START button or the Speed + button. After a moment, the walking belt will begin to move at 1.0 mph. **When the next “chirp” is heard, the speed and incline will change to the next settings of the program.**

When the program is completed, the walking belt will stop and the Time display will begin to flash. Note: To use another program, press the STOP button and go to step 5.

Note: If the speed or incline of the treadmill does not change when a “chirp” is heard, make sure that the iFIT.com indicator is lit and that the Time display is not flashing. In addition, make sure that the audio cable is properly connected, that it is fully plugged in, and that it is not wrapped around a power cord.

8 Follow your progress with the LED track and the displays.

See step 5 on page 12.

9 When the program has ended, remove the key.

See step 6 on page 14.

THE INFORMATION MODE/DEMO MODE

The console features an information mode that keeps track of the total number of hours that the treadmill has been operated and the total number of miles that the walking belt has moved. The information mode also allows you to switch the console from miles per hour to kilometres per hour. In addition, the information mode allows you to turn on and turn off the demo mode.

To select the information mode, hold down the STOP button whilst inserting the key into the console. When the information mode is selected, the following information will be shown:

The Time display will show the total number of hours that the treadmill has been used.

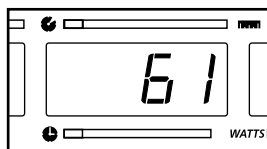

The Distance/Watts display will show the total number of miles that the walking belt has moved.

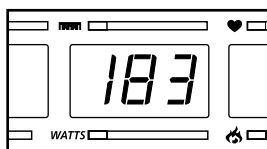

An E, for English miles, or an M, for metric kilometres, will appear in the Speed/ Pace display. Press the Speed + button to change the unit of measurement.

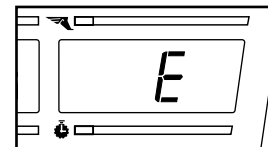

IMPORTANT: The Heart Rate/Calories display should be blank. If a “d” appears in the display, the console is in the “demo” mode.

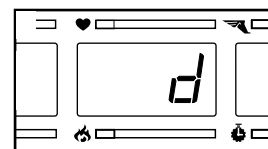

This mode is intended to be used only when a treadmill is displayed in a store. When the console is in the demo mode, the power cord can be plugged in, the key can be removed from the console, and the displays and indicators on the console will automatically light in a preset sequence, although the buttons on the console will not operate. **If a “d” appears in the Heart Rate/Calories display when the information mode is selected, press the Speed – button so the display is blank.**

To exit the information mode, remove the key from the console.

HOW TO FOLD AND MOVE THE TREADMILL

HOW TO FOLD THE TREADMILL FOR STORAGE

Before folding the treadmill, adjust the incline to the lowest position. If this is not done, the treadmill may be permanently damaged. Remove the key and unplug the power cord. **CAUTION:** You must be able to safely lift 20 kg (45 lbs.) in order to raise, lower, or move the treadmill.

1. Hold the treadmill with your hands in the locations shown at the right. **CAUTION: To decrease the possibility of injury, bend your legs and keep your back straight. As you raise the treadmill, make sure to lift with your legs rather than your back.** Raise the treadmill about halfway to the vertical position.

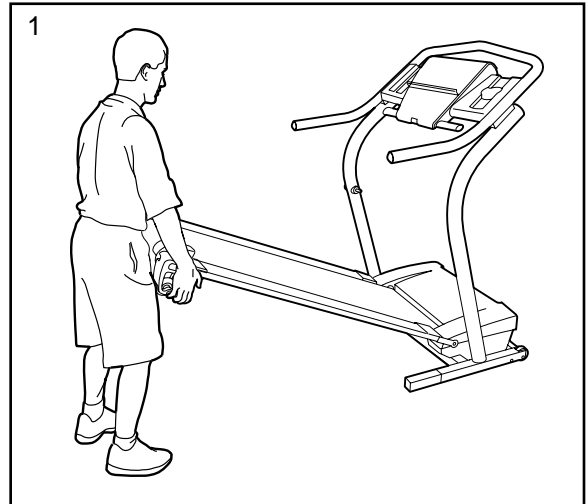

2. Move your right hand to the position shown and hold the treadmill firmly. Using your left hand, pull the latch knob to the left and hold it. Raise the treadmill until the catch passes the pin on the knob. Release the knob. **Make sure that the catch is held securely by the pin on the knob.**

To protect the floor or carpet from damage, place a mat under the treadmill. Keep the treadmill out of direct sunlight. Do not leave the treadmill in the storage position in temperatures above 30° C (85° F).

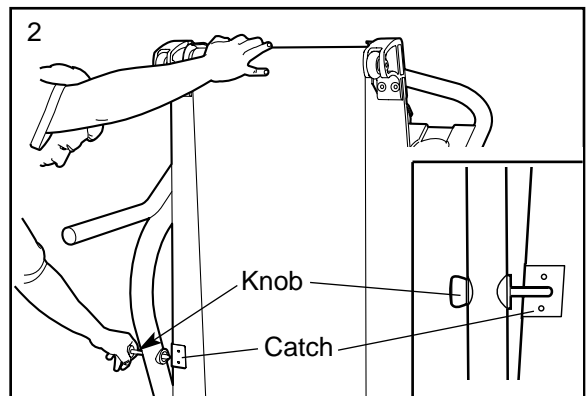

HOW TO MOVE THE TREADMILL

Before moving the treadmill, convert the treadmill to the storage position as described above. **Make sure that the catch is held securely by the pin on the knob.**

1. Hold the handrails as shown and place one foot against a wheel.
2. Tilt the treadmill back until it rolls freely on the front wheels. Carefully move the treadmill to the desired location. **Never move the treadmill without tipping it back. To reduce the risk of injury, use extreme caution whilst moving the treadmill. Do not attempt to move the treadmill over an uneven surface.**
3. Place one foot on wheel, and carefully lower the treadmill until it is resting in the storage position.



HOW TO LOWER THE TREADMILL FOR USE

1. Refer to drawing 2. Hold the upper end of the treadmill with your right hand as shown. Pull the lock knob to the left and hold it. Pivot the treadmill down until the frame is past the pin on the lock knob.
2. Refer to drawing 1. Hold the treadmill firmly with both hands, and lower the treadmill to the floor. **CAUTION: To decrease the possibility of injury, bend your legs and keep your back straight.**

TROUBLESHOOTING

Most treadmill problems can be solved by following the steps below. Find the symptom that applies, and follow the steps listed. If further assistance is needed, please call our Customer Service Department.

PROBLEM: The power does not turn on

SOLUTION: a. Make sure that the power cord is plugged into a properly earthed outlet (see page 9). If an extension cord is needed, use only a 3-conductor, 1 mm² (14-gauge) cord that is no longer than 1.5 m (5 ft.).

b. After the power cord has been plugged in, make sure that the key is fully inserted into the console.

c. Check the circuit breaker located on the treadmill near the power cord. If the switch protrudes as shown, the circuit breaker has tripped. To reset the circuit breaker, wait for five minutes and then press the switch back in.

d. Check the on/off switch located on the treadmill near the power cord. The switch must be in the on position.

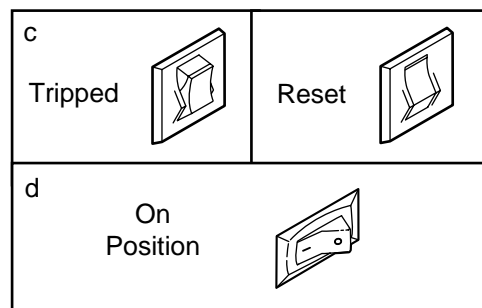

PROBLEM: The power turns off during use

SOLUTION: a. Check the circuit breaker located on the treadmill frame near the power cord (see c. above). If the circuit breaker has tripped, wait for five minutes and then press the switch back in.

b. Make sure that the power cord is plugged in. If it is plugged in, unplug it, wait for five minutes, and then plug it back in.

c. Remove the key from the console. Reinsert the key fully into the console.

d. Make sure that the on/off switch is in the on position.

e. If the treadmill still will not run, please call our Customer Service Department.

PROBLEM: The displays of the console do not function properly

SOLUTION: a. Remove the key from the console and **unplug the power cord**. Carefully tip the treadmill down as shown in drawing a. Remove the Screws (66) from the hood. Raise the Uprights (110) and carefully remove the hood.

Locate the Reed Switch (35) and the Magnet (30) on the left side of the Pulley (29). Turn the Pulley until the Magnet is aligned with the Reed Switch. **Make sure that the gap between the Magnet and the Reed Switch is about 3 mm (1/8 in.)**. If necessary, loosen the Screw (49) and move the Reed Switch slightly. Retighten the Screw. Re-attach the hood, and run the treadmill for a few minutes to check for a correct speed reading.

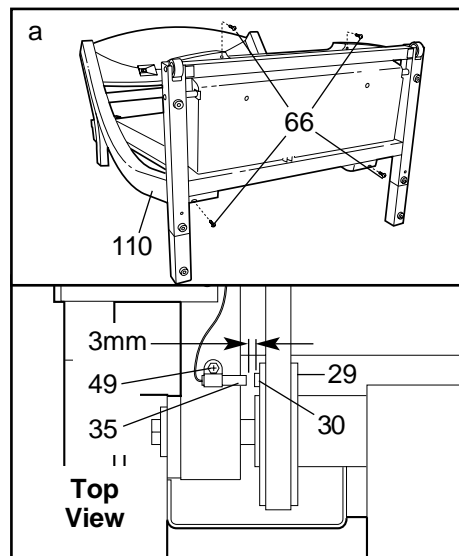

PROBLEM: The walking belt slows when walked on

SOLUTION: a. If an extension cord is needed, use only a 3-conductor, 1 mm² (14-gauge) cord that is no longer than 1.5 m (5 ft.).

b. If the walking belt is overtightened, treadmill performance may decrease and the walking belt may become damaged. Remove the key and **UNPLUG THE POWER CORD**. Using the allen wrench, turn both rear roller adjustment bolts counterclockwise, 1/4 of a turn. When the walking belt is properly tightened, you should be able to lift each side of the walking belt 5 to 7 cm (3 to 4 in.) off the walking platform. Be careful to keep the walking belt centred. Plug in the power cord, insert the key and run the treadmill for a few minutes. Repeat until the walking belt is properly tightened.

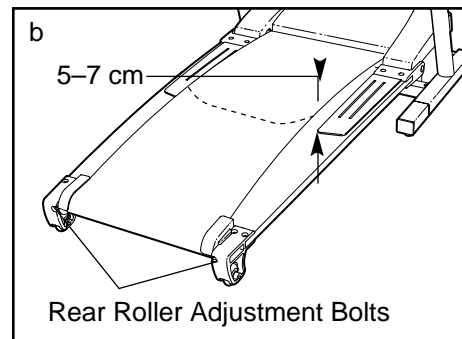

c. If the walking belt still slows when walked on, please call our Customer Service Department.

PROBLEM: The walking belt is off-centre or slips when walked on

SOLUTION: a. If the walking belt is off-centre, first remove the key and **UNPLUG THE POWER CORD**. If the walking belt has shifted to the left, use the allen wrench to turn the left rear roller bolt clockwise 1/2 of a turn; if the walking belt has shifted to the right, turn the bolt counterclockwise 1/2 of a turn. Be careful not to overtighten the walking belt. Plug in the power cord, insert the key and run the treadmill for a few minutes. Repeat until the walking belt is centred.

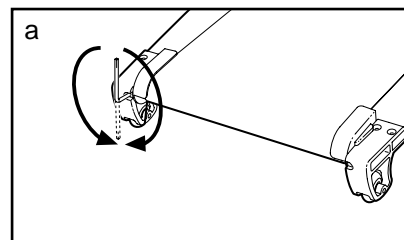

b. If the walking belt slips when walked on, first remove the key and **UNPLUG THE POWER CORD**. Using the allen wrench, turn both rear roller bolts clockwise, 1/4 of a turn. When the walking belt is correctly tightened, you should be able to lift each side of the walking belt 5 to 7 cm (3 to 4 in.) off the walking platform. Be careful to keep the walking belt centred. Plug in the power cord, insert the key and carefully walk on the treadmill for a few minutes. Repeat until the walking belt is properly tightened.

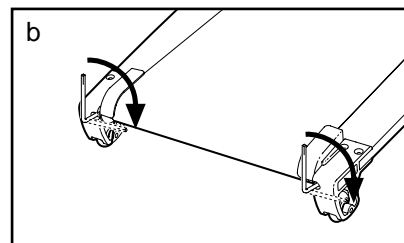

PROBLEM: The incline of the treadmill does not change correctly or does not change when iFIT.com CD's and videos are played

SOLUTION: a. With the key in the console, press one of the Incline buttons. **Whilst the incline is changing, remove the key.** After a few seconds, re-insert the key. The treadmill will automatically rise to the maximum incline level and then return to the minimum level. This will recalibrate the incline system.

CONDITIONING GUIDELINES

⚠️ WARNING: Before beginning this or any exercise program, consult your physician. This is especially important for individuals over the age of 35 or individuals with pre-existing health problems.

The pulse sensors are not a medical device. Various factors, including your movement, may affect the accuracy of heart rate readings. The sensors are intended only as an exercise aid in determining heart rate trends in general.

The following guidelines will help you to plan your exercise program. For more detailed exercise information, obtain a reputable book or consult your physician.

EXERCISE INTENSITY

Whether your goal is to burn fat or to strengthen your cardiovascular system, the key to achieving the desired results is to exercise with the proper intensity. The proper intensity level can be found by using your heart rate as a guide. The chart below shows recommended heart rates for fat burning and aerobic exercise.

HEART RATE TRAINING ZONES								
AEROBIC	165	155	145	140	130	125	115	
MAX FAT BURN	145	138	130	125	118	110	103	
FAT BURN	125	120	115	110	105	95	90	
Age	20	30	40	50	60	70	80	

To find the proper heart rate for you, first find your age near the bottom of the chart (ages are rounded off to the nearest ten years). Next, find the three numbers above your age. The three numbers define your “training zone.” The lower two numbers are recommended heart rates for fat burning; the higher number is the recommended heart rate for aerobic exercise.

To measure your heart rate during exercise, use the handgrip pulse sensor or the chest pulse sensor.

Fat Burning

To burn fat effectively, you must exercise at a relatively low intensity level for a sustained period of time. During the first few minutes of exercise, your body uses easily accessible carbohydrate calories for en-

ergy. Only after the first few minutes does your body begin to use stored fat calories for energy. If your goal is to burn fat, adjust the speed and incline of the treadmill until your heart rate is near the lowest number in your training zone.

For maximum fat burning, adjust the speed and incline of the treadmill until your heart rate is near the middle number in your training zone.

Aerobic Exercise

If your goal is to strengthen your cardiovascular system, your exercise must be “aerobic.” Aerobic exercise is activity that requires large amounts of oxygen for prolonged periods of time. This increases the demand on the heart to pump blood to the muscles, and on the lungs to oxygenate the blood. For aerobic exercise, adjust the speed and incline of the treadmill until your heart rate is near the highest number in your training zone.

WORKOUT GUIDELINES

Each workout should include the following three parts:

A Warm-up—Start each workout with 5 to 10 minutes of stretching and light exercise. A proper warm-up increases your body temperature, heart rate and circulation in preparation for exercise.

Training Zone Exercise—After warming up, increase the intensity of your exercise until your pulse is in your training zone for 20 to 60 minutes. (During the first few weeks of your exercise program, do not keep your pulse in your training zone for longer than 20 minutes.) Breathe regularly and deeply as you exercise—never hold your breath.

A Cool-down—Finish each workout with 5 to 10 minutes of stretching to cool down. This will increase the flexibility of your muscles and will help prevent post-exercise problems.

EXERCISE FREQUENCY

To maintain or improve your condition, complete three workouts each week, with at least one day of rest between workouts. After a few months, you may complete up to five workouts each week if desired. The key to success is to make exercise a regular and enjoyable part of your everyday life.

PART LIST—Model No. NETL15520

R0802A

To locate the parts listed below, refer to the EXPLODED DRAWING attached in the centre of this manual.

Key No.	Qty.	Description	Key No.	Qty.	Description
1	1	Allen Wrench	51	1	Motor Isolator
2	2	Wheel Bolt	52	1	Incline Motor Bolt (Top)
3	1	Rear Endcap (Left)	53	8	Endcap Washer
4	1	Grounding Nut	54	1	Incline Motor Stop
5	2	Rear Roller Adj. Screw	55	8	Endcap Nut
6	2	Rear Wheel	56	1	Incline Motor Bolt (Bottom)
7	8	Front Wheel Nut/Frame Pivot Nut	57	1	Incline Motor
8	8	Endcap Screw	58	1	Front Roller Bolt
9	1	Roller Guard (Left)	59	4	Plastic Stand-off
10	1	Roller Guard (Right)	60	1	Electronic Plate
11	1	Rear Endcap (Right)	61	1	Controller
12	1	Roller Ground Wire	62	1	Motor Controller Wire
13	2	Motor Bolt	63	1	Power Cord Set
14	1	Rear Roller	64	1	Ferrite Box
15	1	Warning Decal	65	1	On/Off Switch
16	1	Latch Plate	66	4	Belly Pan Screw (Long)
17	1	Idler Arm Bolt	67	1	Audio Wire Nut
18	2	Frame Pivot Bolt	68	1	Circuit Breaker
19	1	Front Endcap (Left)	69	2	Static Decal
20	2	Belt Guide	70	1	12" Audio Wire
21	1	Foot Grip (Left)	71	1	Belly Pan
22	1	Walking Belt	72	4	3/4" Screw
23	1	Walking Deck	73	2	Rear Adj. Lock Washer
24	1	Foot Grip (Right)	74	2	Rear Adj. Spring
25	1	Power Board	75	1	Tension Washer
26	1	Front Endcap (Right)	76	1	Console Base
27	4	Support Bracket Screw	77	1	Book Holder
28	1	Support Bracket	78	1	Console
29	1	Front Roller/Pulley	79	2	Handrail Endcap
30	1	Magnet	80	2	Pulse Grip
31	6	Console Screw (Long)	81	4	Pulse Grip Screw
32	4	Frame Pivot Washer	82	10	Short Console Screw
33	2	Frame Pivot Bushing	83	1	Console Back
34	2	Frame Pivot Spacer	84*	2	Extension Leg Assembly
35	1	Reed Switch	85	2	Extension Leg Endcap
36	1	Reed Switch Clip	86	8	Base Screw
37	1	Tension Bolt	87	2	Incline Motor Spacer
38*	1	Idler Assembly	88	2	Extension Leg
39	1	Idler Arm	89	1	Handrail
40	1	Motor Belt	90	7	Base Pad
41	1	Pulley Spacer	91	1	Motor Hood
42	3	Lift Frame Nut	92	1	8" Wire Tie
43	1	Idler Pulley	93	2	Cable Tie Clamp
44	1	Lift Frame Bushing	94	2	Clamp Screw
45	1	Idler Spring	95	1	Releasable Tie
46	1	Motor	96	2	Lift Pivot Bolt
47	1	Lift Frame	97	2	Front Wheel Bolt
48	2	Motor Mount Bushing	98	2	Front Wheel
49	10	Screw	99	1	Incline Motor Guard
50	1	Jack	100	1	Upright Grommet

Key No.	Qty.	Description	Key No.	Qty.	Description
101	1	Upright Wire Harness	123	1	Chest Strap
102	1	Lock Pin	124	1	Ground Screw
103	1	Pin Clip	125	2	Thrust Washer
104	1	Spring	126	2	Frame Pivot Nut
105	1	Lock Pin Collar	127	1	Console Ground Wire
106	1	Lock Knob Sleeve	128	1	Chest Pulse Wire Harness
107	1	Lock Knob Spacer	129	1	Choke
108	1	Lock Knob	130	1	Filter
109*	1	Latch Assembly	131	1	Pulse Receiver
110	1	Upright	132	1	Receptacle
111	4	Handrail Bolt	133	1	Splitter
112	4	Handrail Washer	#	1	14" Blue Wire, 2F
113	4	Handrail Bushing	#	1	4" Blue Wire, 2F
114	2	Handrail Spacer	#	1	4" Black Wire, 2F
115	1	Grounding Bracket	#	1	12" Green Wire, 2 Ring
116	2	Upright Endcap	#	3	8" Green Wire, F/Ring
117	2	Hand Weight	#	2	4" Green Wire, F/Ring
118	1	Key/Clip	#	1	User's Manual
119	1	iFIT.com Wire			
120	1	Filter Wire			
121	2	Rear Adj. Star Washer			
122	1	Chest Pulse Sensor			

* Includes all parts shown in box

These parts are not illustrated

HOW TO CONNECT YOUR VCR

Note: If your VCR has an unused AUDIO OUT jack, see instruction A below. If the AUDIO OUT jack is being used, see instruction B. If you have a TV with a built-in VCR, see instruction B. If your VCR is connected to your home stereo, see **HOW TO CONNECT YOUR HOME STEREO** on page 21.

- A. Plug one end of the audio cable into the jack on the front of the treadmill near the power cord. Plug the other end of the cable into the adaptor. Plug the adaptor into the AUDIO OUT jack on your VCR.

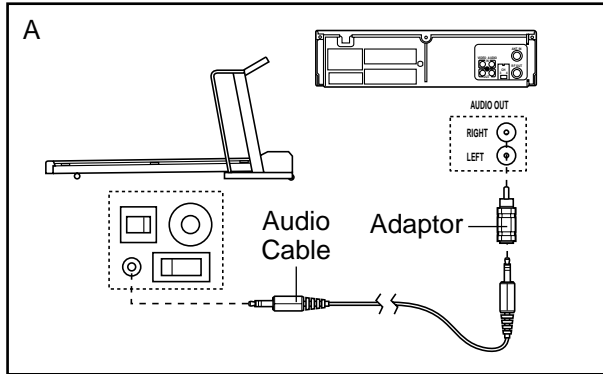

- B. Plug one end of the audio cable into the jack on the front of the treadmill near the power cord. Plug the other end of the cable into the adaptor. Plug the adaptor into an RCA Y-adaptor (available at electronics stores). Next, remove the wire that is currently plugged into the AUDIO OUT jack on your VCR and plug the wire into the unused side of the Y-adaptor. Plug the Y-adaptor into the AUDIO OUT jack on your VCR.

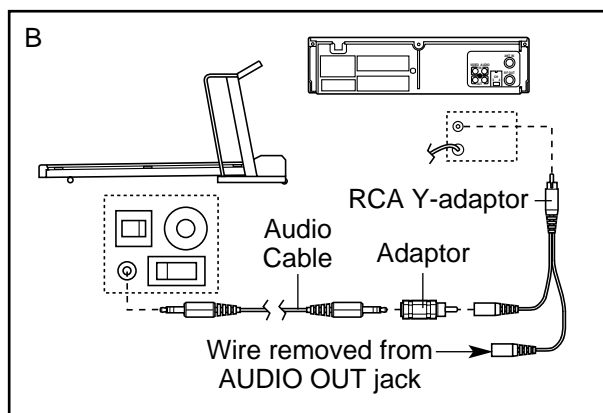

HOW TO USE iFIT.COM CD AND VIDEO PROGRAMS

To use iFIT.com CD's or videocassettes, the treadmill must be connected to your portable CD player, portable stereo, home stereo, computer with CD player, or VCR. See **HOW TO CONNECT THE TREADMILL TO YOUR CD PLAYER, VCR, OR COMPUTER** on page 20. **For information about iFIT.com CD's or videocassettes, send an e-mail to workouts@iFIT.com.**

Follow the steps below to use an iFIT.com CD or video program.

1 Insert the key fully into the console.

See **GETTING STARTED** on page 11.

2 Select the iFIT.com mode.

When the key is inserted, the manual mode will be selected. To use an iFIT.com CD or video program, press the iFIT.com button or press the PROGRAM button repeatedly until the indicator beside the iFIT.com button lights.

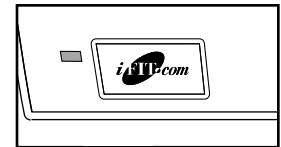

3 Insert the iFIT.com CD or videocassette.

If you are using an iFIT.com CD, insert the CD into your CD player. If you are using an iFIT.com videocassette, insert the videocassette into your VCR.

4 Press the PLAY button on your CD player or VCR.

A moment after the button is pressed, your personal trainer will begin guiding you through your workout. Simply follow your personal trainer's instructions. Note: If the Time display is flashing, press the START button or the Speed + button on the console. The treadmill will not respond to a CD or video program when the Time display is flashing.

During the CD or video program, an electronic "chirping" sound will alert you when the speed and/or incline of the treadmill is about to change. **CAUTION: Always listen for the "chirp" and be prepared for speed and/or incline changes. In some instances, the speed and/or incline may change before the personal trainer describes the change.**

ORDERING REPLACEMENT PARTS

To order replacement parts, contact the ICON Health & Fitness, Ltd. office, or write:

ICON Health & Fitness, Ltd.
Unit 4
Revie Road Industrial Estate
Revie Road, Beeston
Leeds, LS11 8JG
UK

Tel:

08457 089 009

Fax: 0 (044) 113 387 7125

When ordering parts, please be prepared to give the following information:

- the MODEL NUMBER of the product (NETL15520)
- the NAME of the product (NordicTrack® 3500 R treadmill)
- the SERIAL NUMBER of the product (see the front cover of this manual)
- the KEY NUMBER and DESCRIPTION of the part(s) (see the PART LIST on pages 30 and 31 and the EXPLODED DRAWING attached in the centre of this manual)

EXPLODED DRAWING—Model No. NETL15520

R0802A

