

TAD

TAD-M600
MONAURAL POWER AMPLIFIER

OWNER'S MANUAL

IMPORTANT



The lightning flash with arrowhead symbol, within an equilateral triangle, is intended to alert the user to the presence of uninsulated "dangerous voltage" within the product's enclosure that may be of sufficient magnitude to constitute a risk of electric shock to persons.

CAUTION

**RISK OF ELECTRIC SHOCK
DO NOT OPEN**

CAUTION:

TO PREVENT THE RISK OF ELECTRIC SHOCK, DO NOT REMOVE COVER (OR BACK). NO USER-SERVICEABLE PARTS INSIDE. REFER SERVICING TO QUALIFIED SERVICE PERSONNEL.



The exclamation point within an equilateral triangle is intended to alert the user to the presence of important operating and maintenance (servicing) instructions in the literature accompanying the appliance.

D3-4-2-1-1_A1_En

IMPORTANT SAFETY INSTRUCTIONS

- 1) Read these instructions.
- 2) Keep these instructions.
- 3) Heed all warnings.
- 4) Follow all instructions.
- 5) Do not use this apparatus near water.
- 6) Clean only with dry cloth.
- 7) Do not block any ventilation openings. Install in accordance with the manufacturer's instructions.
- 8) Do not install near any heat sources such as radiators, heat registers, stoves, or other apparatus (including amplifiers) that produce heat.
- 9) Do not defeat the safety purpose of the polarized or grounding-type plug. A polarized plug has two blades with one wider than the other. A grounding type plug has two blades and a third grounding prong. The wide blade or the third prong are provided for your safety. If the provided plug does not fit into your outlet, consult an electrician for replacement of the obsolete outlet.
- 10) Protect the power cord from being walked on or pinched particularly at plugs, convenience receptacles, and the point where they exit from the apparatus.
- 11) Only use attachments/accessories specified by the manufacturer.
- 12) Use only with the cart, stand, tripod, bracket, or table specified by the manufacturer, or sold with the apparatus. When a cart is used, use caution when moving the cart/apparatus combination to avoid injury from tip-over.
- 13) Unplug this apparatus during lightning storms or when unused for long periods of time.
- 14) Refer all servicing to qualified service personnel. Servicing is required when the apparatus has been damaged in any way, such as power-supply cord or plug is damaged, liquid has been spilled or objects have fallen into the apparatus, the apparatus has been exposed to rain or moisture, does not operate normally, or has been dropped.



P1-4-2-2_En

WARNING

To prevent a fire hazard, do not place any naked flame sources (such as a lighted candle) on the equipment.

D3-4-2-1-7a_A_En

Operating Environment

Operating environment temperature and humidity:
+5 °C to +35 °C (+41 °F to +95 °F); less than 85 %RH
(cooling vents not blocked)

Do not install this unit in a poorly ventilated area, or in locations exposed to high humidity or direct sunlight (or strong artificial light)

D3-4-2-1-7c*_A1_En

VENTILATION CAUTION

When installing this unit, make sure to leave space around the unit for ventilation to improve heat radiation (at least 60 cm at top, 10 cm at rear, and 30 cm at each side).

WARNING

Slots and openings in the cabinet are provided for ventilation to ensure reliable operation of the product, and to protect it from overheating. To prevent fire hazard, the openings should never be blocked or covered with items (such as newspapers, table-cloths, curtains) or by operating the equipment on thick carpet or a bed.

D3-4-2-1-7b_A_En



Dear Customer:

Selecting fine audio equipment such as the unit you've just purchased is only the start of your musical enjoyment. Now it's time to consider how you can maximize the fun and excitement your equipment offers. This manufacturer and the Electronic Industries Association's Consumer Electronics Group want you to get the most out of your equipment by playing it at a safe level. One that lets the sound come through loud and clear without annoying blaring or distortion-and, most importantly, without affecting your sensitive hearing.

Sound can be deceiving. Over time your hearing "comfort level" adapts to higher volumes of sound. So what sounds "normal" can actually be loud and harmful to your hearing. Guard against this by setting your equipment at a safe level BEFORE your hearing adapts.

To establish a safe level:

- Start your volume control at a low setting.
- Slowly increase the sound until you can hear it comfortably and clearly, and without distortion.

Once you have established a comfortable sound level:

- Set the dial and leave it there.

Taking a minute to do this now will help to prevent hearing damage or loss in the future. After all, we want you listening for a lifetime.

We Want You Listening For A Lifetime

Used wisely, your new sound equipment will provide a lifetime of fun and enjoyment. Since hearing damage from loud noise is often undetectable until it is too late, this manufacturer and the Electronic Industries Association's Consumer Electronics Group recommend you avoid prolonged exposure to excessive noise. This list of sound levels is included for your protection.

**Decibel
Level Example**

30	Quiet library, soft whispers
40	Living room, refrigerator, bedroom away from traffic
50	Light traffic, normal conversation, quiet office
60	Air conditioner at 20 feet, sewing machine
70	Vacuum cleaner, hair dryer, noisy restaurant
80	Average city traffic, garbage disposals, alarm clock at two feet.

THE FOLLOWING NOISES CAN BE DANGEROUS UNDER CONSTANT EXPOSURE

90	Subway, motorcycle, truck traffic, lawn mower
100	Garbage truck, chain saw, pneumatic drill
120	Rock band concert in front of speakers, thunderclap
140	Gunshot blast, jet plane
180	Rocket launching pad

Information courtesy of the Deafness Research Foundation.



Thank you for buying this TAD product. Please read through these operating instructions so you will know how to operate your model properly. After you have finished reading the instructions, put them away in a safe place for future reference.

INTRODUCTION	6
Features.....	6
BEFORE YOU START	7
Checking what's in the box.....	7
Controls and displays.....	7
INSTALLATION AND CONNECTIONS	8
Installation.....	8
How to install	8
Adjusting the spike height	9
Connecting your equipment.....	10
Connecting to the Pre-Amplifier.....	10
Bi-wire connection.....	11
Connecting to the speaker system.....	12
Connecting the power cord	13
TO BEGIN PLAYBACK	14
Before turning on the power.....	14
Playback	14
Protection circuit.....	14
TROUBLESHOOTING.....	15
SPECIFICATIONS	16
Maintenance	17

INTRODUCTION

Inspiring the joy of listening

Technical Audio Devices Laboratories, Inc. (TADL) grew from the spirit to discover technologies to perfectly recreate the pure sound of live performances with uncompromising craftsmanship. We have inherited our philosophy from Bart Locanthi—recognized across the globe as the ultimate sound technologist—who believed that genuine technology is true to the basics and that genuine technology places greater importance on sound quality than on technology for its own sake. At TADL, we are honing our technology to create equipment that reproduces musical sounds that evoke both the energy and impact of live music.

Features

Symmetry: Duallogic-Circuit Technology

In order to drive the speaker diaphragms correctly, it is crucial that the positive and negative current paths in the voice coils be precisely symmetrical. Toward the end of achieving this perfect balance, we have incorporated symmetrical design in the current mode, electrical circuits, and speaker structure.

Damping technology: Vibration-Absorber Technology

Improvements in the quality of vibration damping have been achieved by using cast iron as a low-resonance material for the chassis, adopting an adjustable point-support structure for the spikes and a 10 mm-thick aluminum vibration damper between the transformer and chassis.

Low center of gravity: Lower Weight-Balanced Frame

The monocoque chassis is constructed from 35 kg of cast iron in order to produce a massive and stable foundation. In addition, the TAD-M600 has adopted a wide-tread chassis structure by locating the legs on the outer edges of its body, further lowering its relative center of gravity.

Drive power: 600 W/4 Ω rated output

A balanced-amplifier connection has been used to combine a 5-parallel push-pull amplifier with multi-emitter transistors producing brilliant high-frequency characteristics, so that the TAD-M600 can output 600 W/4 Ω , 300 W/8 Ω with ease.

High-capacity power source

A power transformer consisting of two EI 133 x 85 transformers and a high-capacity filter condenser consisting of four 33 000 μ F are used to create a high-power source strong enough to accurately drive the speakers even at high output levels.

Protection circuit

In the event of a short circuit in the speaker terminals, electrical overload, or abnormal heating due to a contingency, the protection circuit is activated. When activated, this circuit shuts off the power to the amp in order to prevent further heating, while informing the user through the color of the power indicator light. This protection circuit function assures your amplifier and speakers of safety from damage resulting from such anomalies.

Checking what's in the box

Please check that you have received the following supplied accessories in the accessory box.

- Power cord x 1

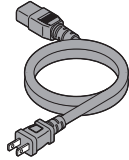

- Hexagon wrench x 1



- Spike bases x 4

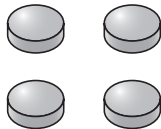

- Spike base template x 1
- Operating Instructions (this document)

Controls and displays

Front panel

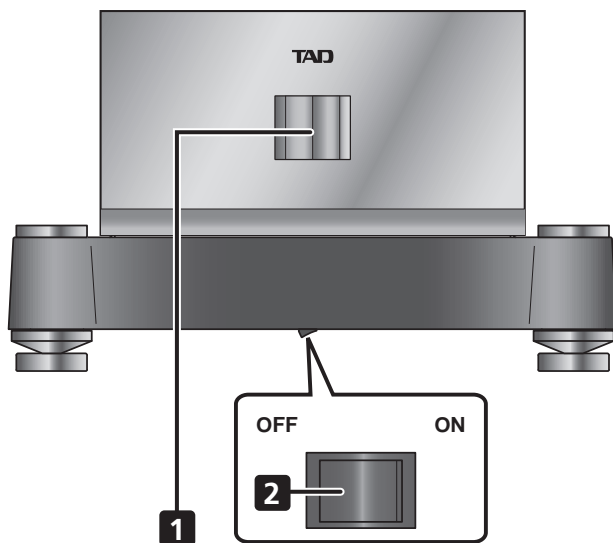

1. Power indicator

Indicates whether the power is turned on or off. The indicator will light red during start up or if there is a malfunction. The indicator will light yellow when the unit is ready to operate. If the power indicator light turns from yellow to red, turn off the power and refer to *Protection circuit* on page 14. If the trouble is still not resolved, ask your dealer.

2. Power switch

Press to turn the power on/off. Flip the switch to the right to turn the power on; flip the switch to the left to turn the power off.

Rear panel



3. INPUT terminal (BALANCED)

Connect to Pre-Amplifier.

4. AC IN connector

Connect the accessory power cord here.

5. SPEAKERS terminals

Connect speakers with impedance of 4 Ω to 16 Ω .

INSTALLATION AND CONNECTIONS

Installation

WARNING

- As the TAD-M600 is a large and heavy unit, make sure to move, unpack and install with four or more people.
- When installing, choose a level and flat surface that can sufficiently withstand the weight of this unit. Failure to do so could cause the unit to fall, resulting in an accident.
It is recommended that the TAD-M600 be installed directly on a solid floor surface. If installed on a shelf, the user is responsible for confirming that the location is fully able to support the heavy weight of the amplifier.
- To promote heat-emission, do not put objects on top of the TAD-M600 or cover with a sheet (such as cloth or curtains) while operating. Failure to do so could cause the unit to malfunction through abnormal heating.

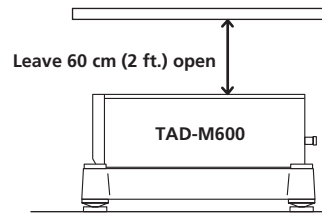
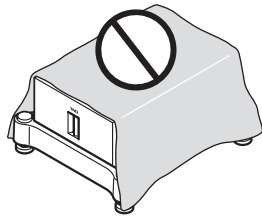

CAUTION

- As the TAD-M600 emits a large amount of heat, do not place this unit on top of soft surfaces (such as carpeting or cushions) or in small spaces.

How to install

In order to improve sound quality and prevent damage to the floor or other installation surface, please use the accessory spike bases.

1. Place the provided spike bases on the area of the installation site where the spikes will contact.

Lay down the spike base template and place the spike bases on the corners of the template to accurately locate the spike bases.

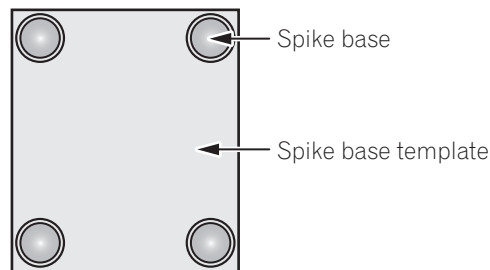

2. Remove the spike base template and place the TAD-M600.

Remove the spike base template carefully, taking care not to move the spike bases.

Adjusting the spike height

1. Remove the cover on the rear right leg of the TAD-M600 as indicated below.

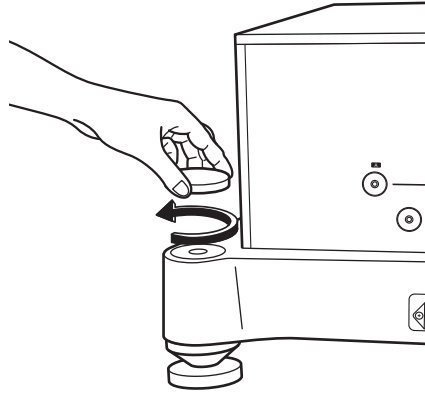

2. Insert the provided hexagon wrench and adjust the spike height so that the TAD-M600 does not wobble.

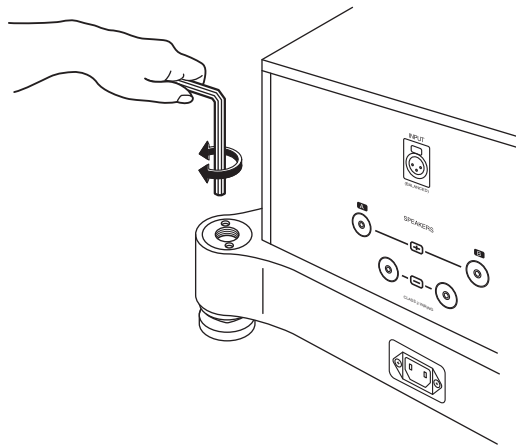

3. Replace the cover removed in step 1.

Connecting your equipment

⚠ CAUTION

- Do not turn on the power switch to the TAD-M600 or the other components until all connections have been completed.

We recommend that you place the speakers at the desired location before performing connections. Use commercially available speaker cables for connections. When connecting other components, make sure to turn the power off and unplug the other components before connecting.

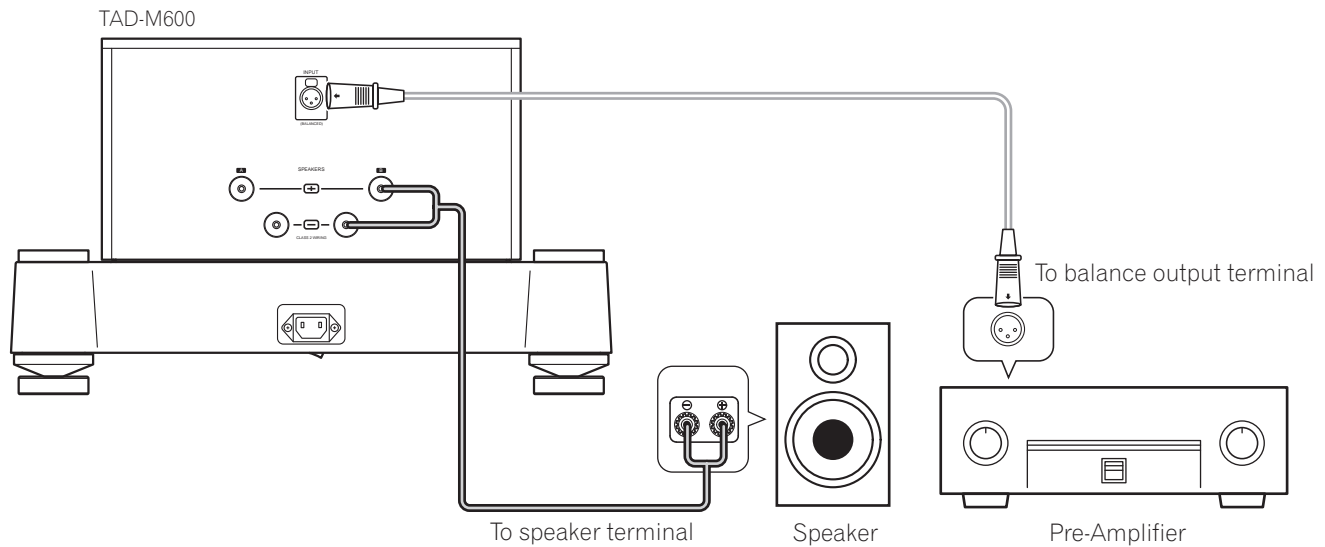

Connecting to the Pre-Amplifier

Connect a balance cable with an XLR plug (sold separately) to the INPUT (BALANCED) terminal of the TAD-M600 and the Pre-Amplifier's balance output terminal.

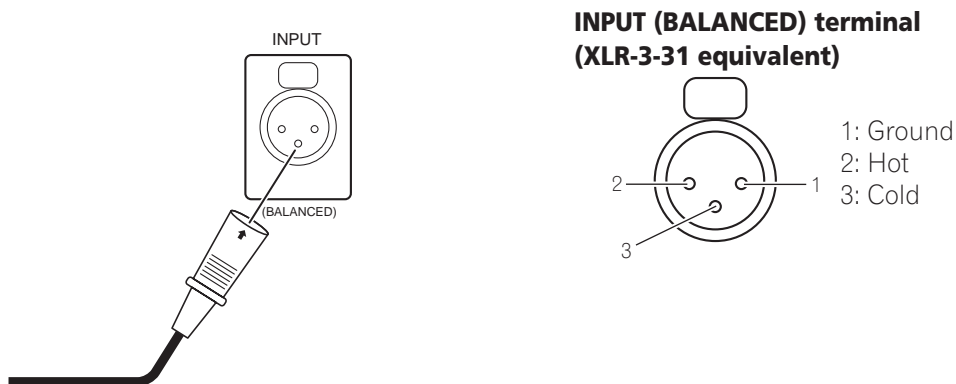

Bi-wire connection

The bi-wire connection uses two speaker cables on one amplifier to connect to the speaker's low-frequency input terminal and high-frequency input terminal.

In order to connect speakers to this unit using a bi-wire connection, the speakers must be bi-wiring compliant. Align the High and Low wires correctly to connect.

[An example of connections made to a speaker system with bi-wire connection terminals]

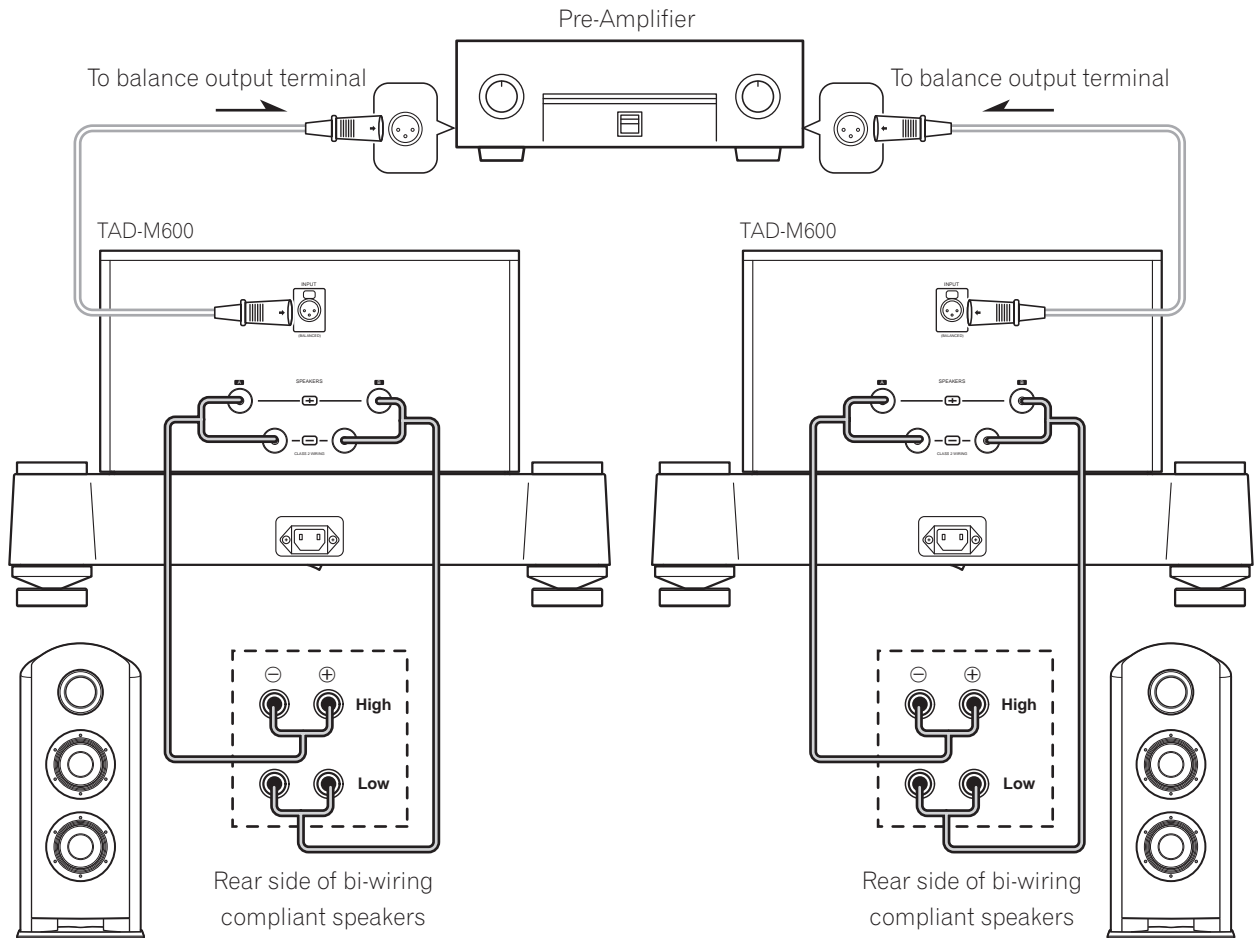

Note

SPEAKERS A terminals and SPEAKERS B terminals produce the same output. High and Low connectors can be made to either terminals A or B.

CAUTION

- When using bi-wire connections, make sure to remove the short bar connectors on the High-Low terminals of the speakers to prevent negative effects on the amplifier. Refer to the operating instructions of your speaker system for further information.

Connecting to the speaker system

CAUTION

- The input terminals of speaker systems have a negative (-) pole and a positive (+) pole. Make sure to align these poles correctly when connecting to the speaker terminals of the TAD-M600.
- Make sure to use speakers with an impedance of 4 Ω to 16 Ω .
- Use speaker cables with a large electrical capacity and make sure no warps or shorts are present. Using speaker cables with a small electrical capacity or making imperfect connections could affect the sound quality of your speakers or cause abnormal heating and shortage.
- Make sure that all the bare speaker wire is twisted together and inserted fully into the speaker terminal. If any of the bare speaker wire touches the back panel it may cause the power to cut off as a safety measure.
- These speaker terminals carry **HAZARDOUS LIVE VOLTAGE**. To prevent the risk of electric shock when connecting or disconnecting the speaker cables, disconnect the power cord before touching any uninsulated parts.

How to connect the speaker system

Connect the positive (+) terminal of the speaker system to the positive (+) terminal of the TAD-M600.
Connect the negative (-) terminal of the speaker system to the negative (-) terminal of the TAD-M600.

Connecting the speaker cable

1. Remove 15 mm ($1/10$ in.) of the protective insulation to the speaker cable, and twist the core wires together.
2. Turn the speaker terminal knob to the left. (↺)
The terminal knob will slide out and create a gap.
3. Insert the speaker wire into the gap and turn the terminal knob to the right to tighten. (↻)

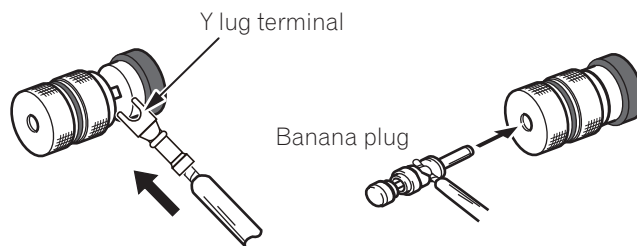
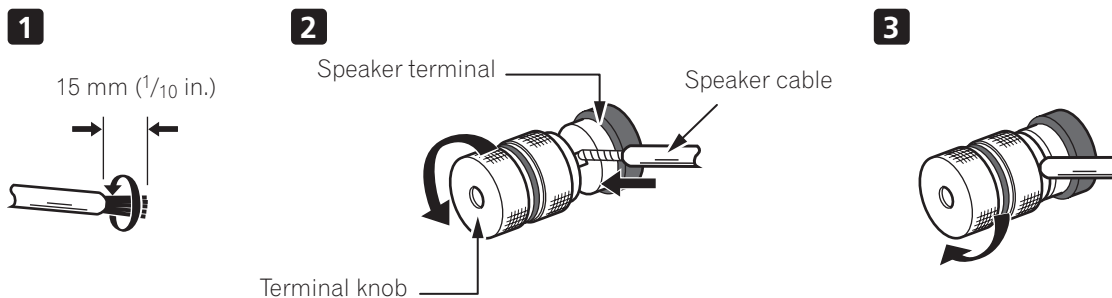

Y lug terminals and banana plugs may also be connected (refer to your plug's operation manual for further information).

Connecting the power cord

Once all connections have been made, plug in the power cord to a power outlet (AC 120 V).



- Although the power cord to the TAD-M600 is removable, do not attempt to use a power cord other than the supplied cord.

- Connect the power plug to a power outlet and turn the power switch on to power up the TAD-M600. Upon power up, there will be an eight second mute period. While muted, the power indicator will light red. The power indicator will turn yellow once the TAD-M600 is ready to be operated.
- When not using the TAD-M600 for a long period of time (due to travel or other reasons), be sure to unplug the power cord from the power outlet.
- Always turn the power switch off before unplugging the power cord to the TAD-M600.

How to connect the power cord

1. Connect the supplied power cord to the AC IN connector of the TAD-M600.
2. Connect the power plug to a power outlet (AC 120 V).

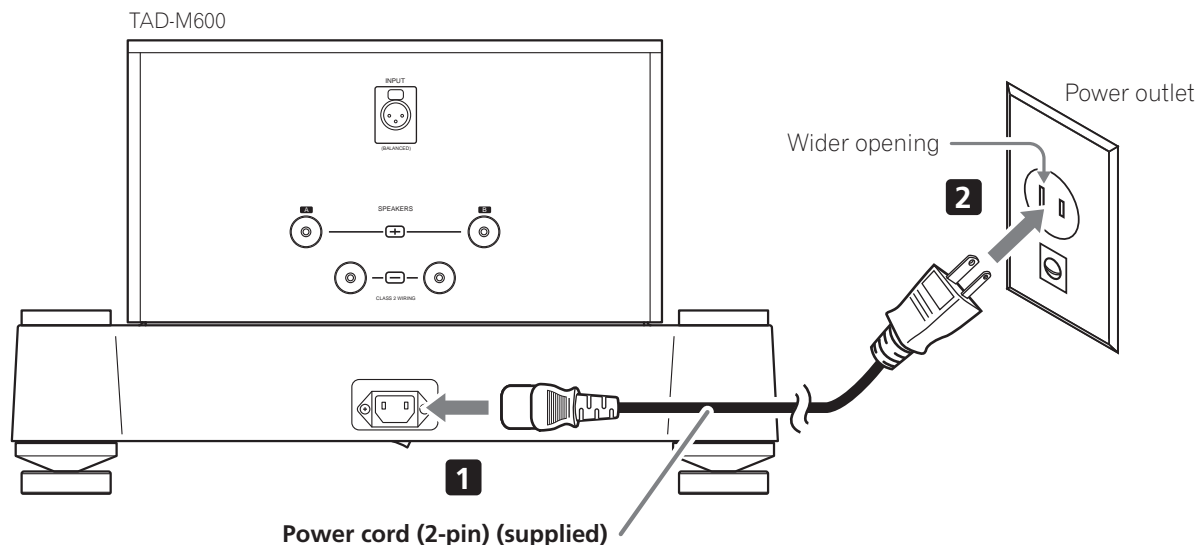

CAUTION

- As the TAD-M600 has high power consumption, be sure to connect the plug to a power outlet providing sufficient electrical capacity. (Connecting to a power outlet with low electrical capacity could result in abnormal heating of the plug connection.)
- Handle the power cord by the plug part. Do not pull out the plug by tugging the cord, and never touch the power cord when your hands are wet, as this could cause a short circuit or electric shock. Do not place the unit, a piece of furniture, or other object on the power cord or pinch the cord in any other way. Never make a knot in the cord or tie it with other cables. The power cords should be routed so that they are not likely to be stepped on. A damaged power cord can cause a fire or give you an electric shock. Check the power cord once in a while. If you find it damaged, ask your dealer for a replacement.

TO BEGIN PLAYBACK

Before turning on the power

Make sure that the input terminals and output terminals are securely connected.

Playback

1. **Turn the volume knob of the Pre-Amplifier to its lowest setting.**
2. **Turn the Pre-Amplifier's power on.**
3. **Turn the TAD-M600's power on.**
The power indicator will light red for eight seconds. The light will turn yellow once the TAD-M600 is ready to operate. Use the Pre-Amplifier's volume knob to adjust the volume.
4. **To turn off the unit after use, first turn the volume knob of the Pre-Amplifier to its lowest setting, then turn off both the Pre-Amplifier and the TAD-M600.**

Protection circuit

The TAD-M600 is provided with a built-in automatic protection circuit to prevent electrical damage to the amplifier and speakers. When the protection circuit operates, the power indicator will light red, and no sound will be produced from the speakers. The protection circuit may operate in the following circumstances:

- **When power is first turned ON**

In order to silence potential noise during startup, the muting circuit operates for eight seconds; the indicator lights red during this time.

- **In event of malfunction**

In the event of a short-circuit between speaker terminals, excessive load, or abnormal heat generation, the protection circuit will operate and the indicator will light red. The protection circuit is of the auto reset type. In the event the protection circuit operates due to a malfunction, turn off the power, eliminate the source of the malfunction, and turn the power on again.

Incorrect operations are often mistaken for trouble and malfunctions. If you think that there is something wrong with this component, check the points below. Sometimes the trouble may lie in another component. Investigate the other components and electrical appliances being used. If the trouble cannot be rectified even after exercising the checks listed below, ask your dealer.

Symptom	Possible cause	Remedy
Power does not turn on.	<ul style="list-style-type: none">● The power plug is not connected to the power outlet.● The power cord is not connected to the AC IN connector of the TAD-M600.	<ul style="list-style-type: none">● Firmly plug in the power cord to the power outlet.● Firmly plug in the power cord to the AC IN connector.
No sound output.	<ul style="list-style-type: none">● The speaker cable is disconnected or is not connected correctly.● The terminal or the speaker cable plug is dirty.● The power indicator light is red.	<ul style="list-style-type: none">● Firmly connect the speaker cable.● Clean the terminal and plug.● Refer to <i>Protection circuit</i> on page 14 and eliminate the cause.

SPECIFICATIONS

■ Amplifier Section

Power output	600 W (20 Hz to 20 kHz, T.H.D., 0.2 %, 4 Ω) 300 W (20 Hz to 20 kHz, T.H.D., 0.2 %, 8 Ω)
Rated distortion	Less than 0.03 % (20 Hz to 20 kHz, 300 W, 4 Ω)
Signal-to-Noise Ratio (IHF, short circuited, A network)	125 dB or higher
Frequency response	1 Hz to 100 kHz, $^{+0}_{-1}$ dB
Gain.....	29.5 dB
Input terminal (Sensitivity/ Impedance)	1.5 V / 220 k Ω

■ Power section/miscellaneous

Power requirements.....	AC 120 V, 60 Hz
Power consumption	520 W
Dimensions	516 mm (W) \times 297 mm (H) \times 622 mm (D) (20 $\frac{5}{16}$ in. (W) \times 11 $\frac{11}{16}$ in. (H) \times 24 $\frac{1}{2}$ in. (D))
Dimensions (When using spike bases).....	516 mm (W) \times 307 mm (H) \times 622 mm (D) (20 $\frac{5}{16}$ in. (W) \times 12 $\frac{1}{16}$ in. (H) \times 24 $\frac{1}{2}$ in. (D))
Weight	90.0 kg (198.4 lb)

■ Accessories

Power cord	1
Spike bases	4
Spike base template	1
Hexagon wrench.....	1
Operating Instructions (this document).....	1

Note

- Specifications and the design are subject to possible modifications without notice, due to improvements.

To ensure long product life, avoid installing this unit in the following locations:

-  • Locations exposed to direct sunlight.
- Humid or poorly ventilated areas.
- Areas of extreme temperatures.
- Areas with vibration.
- Dusty or smoky areas.
- Areas exposed to grease fumes, steam or heat (such as a kitchen).

Maintenance

Use a dry polishing cloth to wipe off dust and dirt. If the surface is extremely dirty, wipe with a soft cloth dipped in neutral cleanser diluted five to six times with water and wrung out well. Do not use volatile chemicals such as paint thinner or benzenes, as these may corrode the surface of the panels. Do not use sprays such as insecticides around the TAD-M600. If you plan on using a chemical cleaning cloth, read the precautionary statements of the chemical cleaning cloth before using.

TAD

TECHNICAL AUDIO DEVICES LABORATORIES, INC.

Published by Pioneer Corporation.
Copyright © 2009 TECHNICAL AUDIO DEVICES LABORATORIES, INC.
All rights reserved.

TECHNICAL AUDIO DEVICES LABORATORIES, INC.

4-1, Meguro 1-Chome, Meguro-ku, Tokyo 153-8654, Japan
<http://tad-labs.com>